



(12) **EUROPEAN PATENT APPLICATION**
 published in accordance with Art. 153(4) EPC

(43) Date of publication:
07.02.2018 Bulletin 2018/06

(51) Int Cl.:
F24F 3/06 ^(2006.01) **F24F 11/02** ^(0000.00)
F25B 41/04 ^(2006.01) **F25B 49/02** ^(2006.01)

(21) Application number: **15887320.8**

(86) International application number:
PCT/CN2015/098290

(22) Date of filing: **22.12.2015**

(87) International publication number:
WO 2016/155370 (06.10.2016 Gazette 2016/40)

(84) Designated Contracting States:
AL AT BE BG CH CY CZ DE DK EE ES FI FR GB GR HR HU IE IS IT LI LT LU LV MC MK MT NL NO PL PT RO RS SE SI SK SM TR
 Designated Extension States:
BA ME
 Designated Validation States:
MA MD

• **Midea Group Co., Ltd.**
Foshan, Guangdong 528311 (CN)

(30) Priority: **31.03.2015 CN 201510151648**

(72) Inventors:
 • **CHEN, Junwei**
Foshan
Guangdong 528311 (CN)
 • **YANG, Guozhong**
Foshan
Guangdong 528311 (CN)

(71) Applicants:
 • **GD Midea Heating & Ventilating Equipment Co., Ltd.**
Foshan Guangdong 528311 (CN)

(74) Representative: **advotec.**
Patent- und Rechtsanwälte
Widenmayerstrasse 4
80538 München (DE)

(54) **VARIABLE REFRIGERANT FLOW SYSTEM**

(57) A variable refrigerant flow system, comprising an outdoor unit apparatus (10), a split-flow apparatus (30) and a plurality of indoor unit apparatuses (21, 22, 23, 24), wherein each of the indoor unit apparatuses (21, 22, 23, 24) comprises an indoor heat exchanger (211, 221, 231, 241) and a throttling element (212, 222, 232, 242), the split-flow apparatus (30) comprises a plurality of first control valves (302A, 302B, 302C, 302D) and a plurality of second control valves (303A, 303B, 303C, 303D) corresponding to each of the indoor unit apparatuses (21, 22, 23, 24), and when any one of the indoor unit apparatuses

(21, 22, 23, 24) receives a mode switching instruction, the mode switching instruction is sent to the split-flow apparatus (30); and according to the mode switching instruction, the split-flow apparatus (30) determines whether the first control valves (302A, 302B, 302C, 302D) and the second control valves (303A, 303B, 303C, 303D) corresponding to the indoor unit apparatuses (21, 22, 23, 24) are open or closed. The variable flow refrigerant system can effectively reduce the noise produced when the indoor unit apparatuses switch modes, thereby improving the user's degree of comfort.

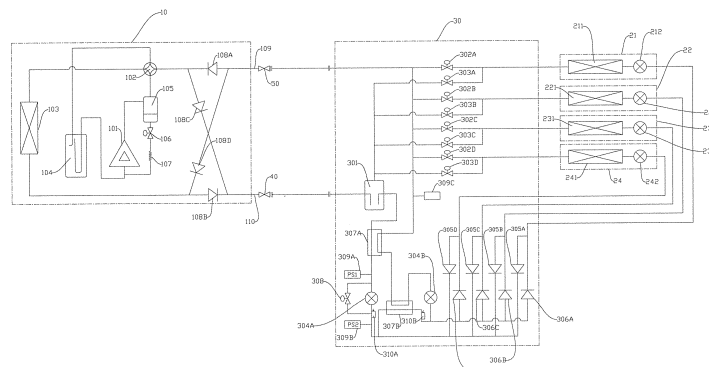

Fig. 1

Description

FIELD

[0001] The present disclosure relates to air conditioning field, and more particularly, to a multi-split system.

BACKGROUND

[0002] With the development of society, the requirements for the air conditioning technology are raised correspondingly, for example, multi-split products are required to realize a simultaneous cooling and heating. Therefore, a heat recovery multi-split system is increasingly popular in the market.

[0003] Currently, there are a two-pipe heat recovery multi-split system and a three-pipe heat recovery multi-split system in the multi-split air conditioner market. The two-pipe heat recovery multi-split system and the three-pipe heat recovery multi-split system correspond to different refrigerant switching devices respectively, usually an unloading valve is opened before switching the operating mode, and the unloading valve is closed after switching the operating mode. However, because the pressure difference between two ends of the unloading valve is large, the bypass noise is big, such that the noise during the mode switching of the indoor unit is too big, which impacts the comfort level of users.

SUMMARY

[0004] Therefore, an objective of the present disclosure is to provide a multi-split system, which may effectively reduce noise generated when the indoor unit switches the mode, and improves the comfort level of users.

[0005] To achieve the above objective, embodiments of the present disclosure provides a multi-split system, including an outdoor unit, a distribution device, a plurality of indoor units, in which each indoor unit includes an indoor heat exchanger and a throttling element, and the distribution device includes a plurality of first controlling valves and a plurality of second controlling valves corresponding to each indoor unit. When any one of the plurality of indoor units receives a mode switching instruction, the indoor unit sends the mode switching instruction to the distribution device; the distribution device determines on or off statuses of a first on/off valve and a second on/off valve corresponding to the indoor unit according to the mode switching instruction.

[0006] By the multi-split system according to embodiments of the present disclosure, when any one of the plurality of indoor units receives a mode switching instruction, the indoor unit sends the mode switching instruction to a distribution device such that the distribution device determines the on or off statuses of the first on/off valve and the second on/off valve corresponding to the indoor unit according to the mode switching instruction

so as to ensure a small pressure difference between the front and back of the on/off valve when the indoor unit switches the mode, and thus noises generated due to a big pressure difference in the mode switching process may be effectively reduced, and the comfort level of users may be improved.

[0007] According to an embodiment of the present disclosure, when any one of the plurality of indoor units is under a heating operating mode, the distribution device controls the second on/off valve corresponding to the indoor unit to open, and controls the first on/off valve corresponding to the indoor unit to close, and controls an opening of the throttling element in the indoor unit by an indoor controller in the indoor unit, in which when the indoor unit receives an instruction indicating switching to a cooling operating mode, the distribution device controls the second on/off valve corresponding to the indoor unit to close, and controls the throttling element in the indoor unit to reach a standby opening by an indoor controller in the indoor unit; controls the throttling element in the indoor unit to reach a maximum opening by the indoor controller in the indoor unit after a first preset time so as to make the indoor unit be filled with a medium-pressure liquid refrigerant, the distribution device controls the first on/off valve corresponding to the indoor unit to open after a second preset time, in which the second preset time is longer than the first preset time.

[0008] According to another embodiment of the present disclosure, when any one of the plurality of indoor units is under a cooling operating mode, the distribution device controls the first on/off valve corresponding to the indoor unit to open, and controls the second on/off valve corresponding to the indoor unit to close, and controls an opening of the throttling element in the indoor unit by an indoor controller in the indoor unit, in which when the indoor unit receives an instruction indicating switching to a heating operating mode, the distribution device controls the first on/off valve corresponding to the indoor unit to close, and controls the throttling element in the indoor unit to reach a maximum opening by the indoor controller in the indoor unit; the distribution device controls the second on/off valve corresponding to the indoor unit to open after a second preset time.

[0009] In embodiments of the present disclosure, the multi-split system includes a two-pipe heat recovery multi-split system and a three-pipe heat recovery multi-split system.

[0010] In embodiments of the present disclosure, when any one of the plurality of indoor units is under a cooling operating mode, the indoor unit may be controlled to be switched to a cooling standby mode, a cooling stopping mode or a heating operating mode; when any one of the plurality of indoor units is under a cooling standby mode, the indoor unit may be controlled to be switched to a cooling stopping mode or a heating operating mode; when any one of the plurality of indoor units is under a cooling stopping mode, the indoor unit may be controlled to be switched to a cooling operating mode or a heating

operating mode; when any one of the plurality of indoor units is under a heating operating mode, the indoor unit may be controlled to be switched to a heating standby mode, a heating stopping mode or a cooling operating mode; when any one of the plurality of indoor units is under a heating standby mode, the indoor unit may be controlled to be switched to a heating stopping mode or a cooling operating mode; when any one of the plurality of indoor units is under a heating stopping mode, the indoor unit may be controlled to be switched to a cooling operating mode or a heating operating mode.

[0011] In an embodiment, the first preset time may be in a range of 20 to 40 seconds, and the second preset time may be in a range of 50 to 70 seconds.

[0012] In an embodiment, the standby opening may be 72P, and the maximum opening may be 480P.

BRIEF DESCRIPTION OF THE DRAWINGS

[0013]

Fig. 1 is a schematic view of a two-pipe multi-split system according to an embodiment of the present disclosure;

Fig. 2 is a schematic view of a two-pipe multi-split system operating under a pure heating mode according to an embodiment of the present disclosure;

Fig. 3 is a schematic view of a two-pipe multi-split system operating under a main heating mode according to an embodiment of the present disclosure;

Fig. 4 is a schematic view of a two-pipe multi-split system operating under a pure cooling mode according to an embodiment of the present disclosure;

Fig. 5 is a schematic view of a two-pipe multi-split system operating under a main cooling mode according to an embodiment of the present disclosure;

Fig. 6 is a schematic view of a three-pipe multi-split system according to another embodiment of the present disclosure;

Fig. 7 is a schematic view of a three-pipe multi-split system operating under a pure heating mode according to another embodiment of the present disclosure;

Fig. 8 is a schematic view of a three-pipe multi-split system operating under a main heating mode according to another embodiment of the present disclosure;

Fig. 9 is a schematic view of a three-pipe multi-split system operating under a pure cooling mode according to another embodiment of the present disclosure;

Fig. 10 is a schematic view of a three-pipe multi-split system operating under a main cooling mode according to another embodiment of the present disclosure; and

Fig. 11 is a communication network diagram of a multi-split system according to an embodiment of the present disclosure.

DETAILED DESCRIPTION

[0014] Embodiments of the present disclosure will be described in detail in the following descriptions, examples of which are shown in the accompanying drawings, in which the same or similar elements and elements having same or similar functions are denoted by like reference numerals throughout the descriptions. The embodiments described herein with reference to the accompanying drawings are exemplary, which are used to explain the present disclosure, and shall not be construed to limit the present disclosure.

[0015] A multi-split system according to embodiments of the present disclosure will be described below by referring to the accompanying drawings.

[0016] In embodiments of the present disclosure, as shown in Fig. 1 to Fig. 10, the multi-split system includes an outdoor unit 10, a distribution device 30 and a plurality of indoor units (such as four indoor units 21, 22, 23, 24).

[0017] Each indoor unit includes an indoor heat exchanger and a throttling element, the distribution device 30 includes a plurality of first controlling valves and a plurality of second controlling valves corresponding to each indoor unit. When any one of the plurality of indoor units receives a mode switching instruction, the indoor unit sends the mode switching instruction to the distribution device 30 such that the distribution device 30 determines on or off statuses of the first on/off valve and the second on/off valve corresponding to the indoor unit according to the mode switching instruction.

[0018] In embodiments of the present disclosure, the multi-split system may include a two-pipe heat recovery multi-split system and a three-pipe heat recovery multi-split system.

[0019] In the two-pipe heat recovery multi-split system according to embodiments of the present disclosure, as shown in Fig. 1 to Fig. 5, the outdoor unit 10 includes a compressor 101, a four-way valve 102, an outdoor heat exchanger 103, an outdoor gas-liquid separator 104, an oil separator 105, a first electromagnetic valve 106, a capillary 107, four one-way valves 108A, 108B, 108C, 108D, a first interface 109 and a second interface 110. The compressor 101 has an exhaust port and a gas returning port, and the four-way valve 102 has a first valve port to a fourth valve port, in which the first valve port is communicated with one of the second valve port and the third valve port, and the fourth valve port is communicated with the other one of the second valve port and the third valve port, and the first valve port is communicated with the exhaust port of the compressor 101 through the oil separator 105, and the fourth valve port is communicated with the gas returning port of the compressor 101 through the outdoor gas-liquid separator 104, and the one-way valve 108A is connected in series between the second valve port and the first interface 109, and the third valve port is connected to a first end of the outdoor heat exchanger 103.

[0020] The distribution device 30 includes a gas-liquid

separator 301, a plurality of first controlling valves (such as four first controlling valves 302A, 302B, 302C, 302D), a plurality of second controlling valves (such as four second controlling valves 303A, 303B, 303C, 303D), a first electronic expansion valve 304A, a second electronic expansion valve 304B, four first one-way valves 305A, 305B, 305C, 305D, four second one-way valves 306A, 306B, 306C, 306D, a first heat exchange assembly 307A and a second heat exchange assembly 307B. The gas-liquid separator 301 has an inlet, a gas outlet and a liquid outlet, the inlet is connected to a second end of the outdoor heat exchanger 103 through a high-pressure stop valve 40 and the one-way valve 108B, the gas outlet is connected to the four second controlling valves 303A, 303B, 303C, 303D respectively; the four first controlling valves 302A, 302B, 302C, 302D are connected to the first interface 109 through the low-pressure stop valve 50 respectively. The first heat exchange assembly 307A and the second heat exchange assembly 307B may be plate heat exchangers, and may also be double-pipe heat exchangers.

[0021] As shown in Fig. 1 to Fig. 5, the first end of the one-way valve 108A is connected between the one-way valve 108B and the second interface 110 through the one-way valve 108C, and the second end of the one-way valve 108A is connected between the one-way valve 108B and the outdoor heat exchanger 103 through the one-way valve 108D.

[0022] The first heat exchange assembly 307A and the second heat exchange assembly 307B each have a first heat exchange flow path and a second heat exchange flow path, and the liquid outlet of the gas-liquid separator 301 is connected to the first heat exchange flow path of the first heat exchange assembly 307A, and the first heat exchange flow path of the first heat exchange assembly 307A is connected to the first electronic expansion valve 304A, and the second heat exchange flow path of the first heat exchange assembly 307A is connected to the second heat exchange flow path of the second heat exchange assembly 307B and the four first controlling valves 302A, 302B, 302C, 302D respectively.

[0023] As shown in Fig. 1 to Fig. 5, each indoor unit includes an indoor heat exchanger and a throttling element. The indoor unit 21 includes an indoor heat exchanger 211 and a throttling element 212, and the indoor unit 22 includes an indoor heat exchanger 221 and a throttling element 222, and the indoor unit 23 includes an indoor heat exchanger 231 and a throttling element 232, and the indoor unit 24 includes an indoor heat exchanger 241 and a throttling element 242. The first end of the indoor heat exchanger in each indoor unit is connected to the corresponding throttling element, the second end of the indoor heat exchanger in each indoor unit is connected to the corresponding first controlling valve and second controlling valve, and the throttling element in each indoor unit is connected to the corresponding first one-way valve and the second one-way valve, and the flow direction of the first one-way valve is opposite to the

flow direction of the second one-way valve. Moreover, the four first one-way valves 305A, 305B, 305C, 305D are all connected to a first common flow path, and the four second one-way valves 306A, 306B, 306C, 306D are all connected to a second common flow path, and the first heat exchange flow path of the second heat exchange assembly 307B is communicated with the first common flow path and the second common flow path respectively, and the first electronic expansion valve 304A is connected to the first common flow path, and the second electronic expansion valve 304B is connected to the second heat exchange flow path of the second heat exchange assembly 307B and the second common flow path respectively, and the first electronic expansion valve 304A is further connected with the second electromagnetic valve 308 in parallel.

[0024] As shown in Fig. 1 to Fig. 5, a pressure sensor 309A and a pressure sensor 309B are provided at two ends of the first electronic expansion valve 304A and the second electromagnetic valve 308 in parallel connection respectively, and a temperature sensor 310A and a temperature sensor 310B are provided at two ends of the first heat exchange flow path of the second heat exchange assembly 307B respectively. In addition, a pressure sensor 309C is provided at one end of the second heat exchange flow path of the first heat exchange assembly 307A.

[0025] In the three-pipe heat recovery multi-split system according to embodiments of the present disclosure, as shown in Fig. 6 to Fig. 10, the outdoor unit 10 includes a compressor 101, two four-way valves 102, 102A, an outdoor heat exchanger 103, an outdoor gas-liquid separator 104, an oil separator 105, a first electromagnetic valve 106, three capillaries 107, 107A, 107B, an electronic expansion valve 112, and a first interface 109, a second interface 110 and a third interface 111. The compressor 101 has an exhaust port and a gas returning port, and the two four-way valves 102, 102A each have a first valve port to a fourth valve port, in which the first valve port is communicated with one of the second valve port and the third valve port, and the fourth valve port is communicated with the other one of the second valve port and the third valve port, in which the first valve port of the four-way valve 102 is connected to the exhaust port of the compressor 101 through the oil separator 105, and the fourth valve port is connected to the gas returning port of the compressor 101 through the outdoor gas-liquid separator 104, and a capillary 107A is connected in parallel between the second valve port and the fourth valve port, and the third valve port is connected to a first end of the outdoor heat exchanger 103. The first valve port of the four-way valve 102A is connected to the third interface 111, the second valve port is connected to the first end of the outdoor heat exchanger 103 directly, and the third valve port is connected to the exhaust port of the compressor 101 through the oil separator 105, and the fourth valve port is connected to the first end of the outdoor heat exchanger 103 through the capillary 107B.

[0026] The distribution device 30 includes a plurality of first controlling valves (such as four first controlling valves 302A, 302B, 302C, 302D) and a plurality of second controlling valves (such as four second controlling valves 303A, 303B, 303C, 303D). The four first controlling valves 302A, 302B, 302C, 302D are connected to the first interface 109 through the low-pressure stop valve 50 respectively, and the four second controlling valves 303A, 303B, 303C, 303D are connected to the third interface 111 through the stop valve 60 respectively.

[0027] As shown in Fig. 6 to Fig. 10, each indoor unit includes an indoor heat exchanger and a throttling element, in which the indoor unit 21 includes an indoor heat exchanger 211 and a throttling element 212, and the indoor unit 22 includes an indoor heat exchanger 221 and a throttling element 222, and the indoor unit 23 includes an indoor heat exchanger 231 and a throttling element 232, and the indoor unit 24 includes an indoor heat exchanger 241 and a throttling element 242. The first end of the indoor heat exchanger in each indoor unit is connected to the corresponding throttling element, and the second end of the indoor heat exchanger in each indoor unit is connected to the corresponding first controlling valve and second controlling valve, and the throttling element in each indoor unit is connected to the second interface 110 through the high-pressure stop valve 40.

[0028] According to an embodiment of the present disclosure, when any one of the plurality of indoor units is under a heating operating mode, the distribution device 30 controls the second on/off valve corresponding to the indoor unit to open, and controls the first on/off valve corresponding to the indoor unit to close, and controls the opening of the throttling element in the indoor unit by an indoor controller in the indoor unit, in which when the indoor unit receives an instruction indicating switching to a cooling operating mode, the distribution device 30 controls the second on/off valve corresponding to the indoor unit to close, and controls the throttling element in the indoor unit to reach a standby opening by an indoor controller in the indoor unit; controls the throttling element in the indoor unit to reach a maximum opening by the indoor controller in the indoor unit after a first preset time so as to make the indoor unit be filled with a medium-pressure liquid refrigerant, the distribution device 30 controls the first on/off valve corresponding to the indoor unit to open after a second preset time to complete a switch to a cooling operating mode from a heating operating mode, which makes the pressure difference between the front and back of the first on/off valve equivalent to a switch between a medium pressure and a low pressure, such that the pressure difference during the mode switching is small, and noise during the mode switching of the indoor unit is reduced. The second preset time is longer than the first preset time.

[0029] In an embodiment, the first preset time may be in a range of 20 to 40 seconds, and the second preset time may be in a range of 50 to 70 seconds.

[0030] In an embodiment, the standby opening may be

72P, and the maximum opening may be 480P.

[0031] According to another embodiment of the present disclosure, when any one of the plurality of indoor units is under a cooling operating mode, the distribution device 30 controls the first on/off valve corresponding to the indoor unit to open, and controls the second on/off valve corresponding to the indoor unit to close, and controls the opening of the throttling element in the indoor unit by an indoor controller in the indoor unit, in which when the indoor unit receives an instruction indicating switching to a heating operating mode, the distribution device 30 controls the first on/off valve corresponding to the indoor unit to close, and controls the throttling element in the indoor unit to reach a maximum opening by the indoor controller in the indoor unit; the distribution device 30 controls the second on/off valve corresponding to the indoor unit to open after a second preset time to complete a switch to a heating operating mode from a cooling operating mode, which makes the pressure difference between the front and back of the second on/off valve equivalent to a switch between a high pressure and a medium pressure, such that the pressure difference during the mode switching is small, and the noise during the mode switching of the indoor unit is reduced.

[0032] In embodiments of the present disclosure, the operating mode of the multi-split system includes a pure cooling mode, a pure heating mode and a simultaneous cooling and heating mode, in which the simultaneous cooling and heating mode includes a main cooling mode and a main heating mode.

[0033] Next, flow directions of refrigerants when the two-pipe multi-split system works under a pure heating mode, a main heating mode, a pure cooling mode and a main cooling mode will be described respectively by referring to Fig. 2 to Fig. 5.

[0034] As shown in Fig. 2, when the outdoor unit 10 determines that the multi-split system works under a pure heating mode, the four indoor units perform heating work. The flow direction of a refrigerant will be described as follows: a high-pressure gas flows into the four-way valve 102 through the oil separator 105 from the exhaust port of the compressor 101, then flows into the gas-liquid separator 301 via the one-way valve 108C, the second interface 110 and the high-pressure stop valve 40, and the high-pressure gas flows into the corresponding four indoor heat exchangers via the four second controlling valves 303A, 303B, 303C, 303D respectively from the gas outlet of the gas-liquid separator 301, and then turns into a high-pressure liquid; then, the four-way high-pressure liquid flows into the first heat exchange flow path of the second heat exchange assembly 307B via the corresponding throttling elements and the four first one-way valves 305A, 305B, 305C, 305D, and turns into a low-pressure gas-liquid two-phase refrigerant via the second electronic expansion valve 304B; the low-pressure gas-liquid two-phase refrigerant flows back to the outdoor unit 10 via the second heat exchange flow path of the second heat exchange assembly 307B and the second heat ex-

change flow path of the first heat exchange assembly 307A, that is, the low-pressure gas-liquid two-phase refrigerant turns into a low-pressure gas after flowing back to the outdoor heat exchanger 103 via the low-pressure stop valve 50, the first interface 109 and the one-way valve 108D, and the low-pressure gas flows back to the gas returning port of the compressor 101 via the four-way valve 102 and the outdoor gas-liquid separator 104.

[0035] As shown in Fig. 3, when the outdoor unit 10 determines that the multi-split system works under a main heating mode, three of the four indoor units perform heating work, and one indoor unit performs cooling work. The flow direction of a refrigerant for heating will be described as follows: a high-pressure gas flows into the four-way valve 102 through the oil separator 105 from the exhaust port of the compressor 101, then flows into the gas-liquid separator 301 via the one-way valve 108C, the second interface 110 and the high-pressure stop valve 40, and the high-pressure gas flows into the indoor heat exchangers in the corresponding three heating indoor units via the three second controlling valves 303A, 303B, 303C respectively from the gas outlet of the gas-liquid separator 301, then turns into a high-pressure liquid, and then the three-way high-pressure liquid flows into the first heat exchange flow path of the second heat exchange assembly 307B via the corresponding throttling elements and the three first one-way valves 305A, 305B, 305C, and turns into a low-pressure gas-liquid two-phase refrigerant via the second electronic expansion valve 304B, and the low-pressure gas-liquid two-phase refrigerant flows back to the outdoor unit 10 via the second heat exchange flow path of the second heat exchange assembly 307B and the second heat exchange flow path of the first heat exchange assembly 307A, that is, the low-pressure gas-liquid two-phase refrigerant turns into a low-pressure gas after flowing back to the outdoor heat exchanger 103 via the low-pressure stop valve 50, the first interface 109 and the one-way valve 108D, and the low-pressure gas flows back to the gas returning port of the compressor 101 via the four-way valve 102 and the outdoor gas-liquid separator 104. The flow direction of a refrigerant for cooling will be described as follows: a part of the high-pressure liquid flowing through the first heat exchange flow path of the second heat exchange assembly 307B further turns into a low-pressure gas-liquid two-phase refrigerant after flowing into the throttling element 242 in the indoor unit 24 via the second one-way valve 306D, then turns into a low-pressure gas via the indoor heat exchanger 241 in the indoor unit 24; after flowing through the first controlling valve 302D, the low-pressure gas flows back to the outdoor unit 10 after being mixed with the low-pressure gas-liquid two-phase refrigerant flowing through the second heat exchange flow path of the second heat exchange assembly 307B and the second heat exchange flow path of the first heat exchange assembly 307A.

[0036] As shown in Fig. 4, when the outdoor unit 10 determines that the multi-split system works under a pure

cooling mode, the four indoor units perform cooling work. The flow direction of a refrigerant will be described as follows: a high-pressure gas flows into the four-way valve 102 through the oil separator 105 from the exhaust port of the compressor 101, then turns into a high-pressure liquid after flowing through the outdoor heat exchanger 103, and the high-pressure liquid flows into the gas-liquid separator 301 via the one-way valve 108B, the second interface 110 and the high-pressure stop valve 40, and the high-pressure liquid flows into the first electronic expansion valve 304A and the second electromagnetic valve 308 via the first heat exchange flow path of the first heat exchange assembly 307A from the liquid outlet of the gas-liquid separator 301, then flows into the four second one-way valves 306A, 306B, 306C, 306D respectively via the first heat exchange flow path of the second heat exchange assembly 307B, and the four-way high-pressure liquid flowing through the four second one-way valves 306A, 306B, 306C, 306D turns into a four-way low-pressure gas-liquid two-phase refrigerant after correspondingly flowing through the throttling elements in the four indoor units respectively, and the four-way low-pressure gas-liquid two-phase refrigerant turns into a four-way low-pressure gas after flowing through the corresponding indoor heat exchangers respectively, and then the low-pressure gas flows back to the outdoor unit 10 correspondingly via the four first controlling valves 302A, 302B, 302C, 302D, that is, the low-pressure gas flows back to the gas returning port of the compressor 101 via the low-pressure stop valve 50, the first interface 109, the one-way valve 108A and the outdoor gas-liquid separator 104.

[0037] As shown in Fig. 5, when the outdoor unit 10 determines that the multi-split system works under a main cooling mode, three of the four indoor units perform cooling works and one indoor unit performs heating work. The flow direction of a refrigerant for cooling will be described as follows: a high-pressure gas flows into the four-way valve 102 through the oil separator 105 from the exhaust port of the compressor 101, then turns into a high-pressure gas-liquid two-phase refrigerant after flowing through the outdoor heat exchanger 103, and the high-pressure gas-liquid two-phase refrigerant flows into the gas-liquid separator 301 via the one-way valve 108B, the second interface 110 and the high-pressure stop valve 40 to perform a gas-liquid separation, in which the high-pressure liquid flows into the first electronic expansion valve 304A and the second electromagnetic valve 308 via the first heat exchange flow path of the first heat exchange assembly 307A from the liquid outlet of the gas-liquid separator 301, then flows into the three second one-way valves 306A, 306B, 306C via the first heat exchange flow path of the second heat exchange assembly 307B respectively, the three-way high-pressure liquid flowing through the three second one-way valves 306A, 306B, 306C turns into a three-way low-pressure gas-liquid two-phase refrigerant after correspondingly flowing through throttling elements in the three indoor units re-

spectively, and the three-way low-pressure gas-liquid two-phase refrigerant turns into three-way low-pressure gas after flowing through the corresponding indoor heat exchangers respectively, then flows back to the outdoor unit 10 correspondingly via the three first controlling valves 302A, 302B, 302C, that is, the low-pressure gas flows back to the gas returning port of the compressor 101 via the low-pressure stop valve 50, the first interface 109, the one-way valve 108A, and the outdoor gas-liquid separator 104. The flow direction of a refrigerant for heating will be described as follows: a high-pressure gas after the gas-liquid separation through the gas-liquid separator 301 flows into the indoor heat exchanger 241 in the indoor unit 24 via the second controlling valve 303D from the gas outlet of the gas-liquid separator 301, then turns into a high-pressure liquid; and after flowing through the throttling element 242 in the indoor unit 24, the high-pressure liquid joins the high-pressure liquid flowing through the first heat exchange flow path of the second heat exchange assembly 307B via the first one-way valve 305D.

[0038] Next, flow directions of the refrigerants when the three-pipe multi-split system works under a pure heating mode, a main heating mode, a pure cooling mode and a main cooling mode will be described respectively by referring to Fig. 7 to Fig. 10.

[0039] As shown in Fig. 7, when the outdoor unit 10 determines that the multi-split system works under a pure heating mode, the four indoor units perform heating work. The flow direction of a refrigerant will be described as follows: a high-pressure gas flows into the four-way valve 102 via the oil separator 105 from the exhaust port of the compressor 101A, then flows into the corresponding four indoor heat exchangers via the third interface 111, the stop valve 60, the four second controlling valves 303A, 303B, 303C, 303D, then turns into a high-pressure liquid, and then the four-way high-pressure liquid flows into the electronic expansion valve 112 via the corresponding throttling elements, the high-pressure stop valve 40 and the second interface 110; and after turning into a low-pressure gas-liquid two-phase refrigerant via the electronic expansion valve 112, the high-pressure liquid turns into a low-pressure gas after flowing through the outdoor heat exchanger 103, and the low-pressure gas flows back to the gas returning port of the compressor 101 via the four-way valve 102 and the outdoor gas-liquid separator 104.

[0040] As shown in Fig. 8, when the outdoor unit 10 determines that the multi-split system works under a main heating mode, three of the four indoor units perform heating work and one indoor unit performs cooling work. The flow direction of a refrigerant for heating will be described as follows: a high-pressure gas flows into the four-way valve 102 via the oil separator 105 from the exhaust port of the compressor 101A, then flows into the indoor heat exchangers in the corresponding three heating indoor units via the third interface 111, the stop valve 60, the three second controlling valves 303A, 303B, 303C, then turns into a high-pressure liquid; then, after the three-

way high-pressure liquid flowing through the corresponding throttling elements, a part of the high-pressure liquid flows into the electronic expansion valve 112 via the high-pressure stop valve 40 and the second interface 110, and the high-pressure liquid turns into a low-pressure gas-liquid two-phase refrigerant via the electronic expansion valve 112, then turns into a low-pressure gas after flowing through the outdoor heat exchanger 103, and the low-pressure gas flows back to the gas returning port of the compressor 101 via the four-way valve 102 and the outdoor gas-liquid separator 104. The flow direction of a refrigerant for cooling will be described as follows: the other part of the high-pressure liquid output via the throttling elements in the three heating indoor units turns into a low-pressure gas-liquid two-phase refrigerant after flowing through the throttling element 242 in the indoor unit 24, then turns into low-pressure gas after flowing through the indoor heat exchanger 241; and after flowing through the low-pressure stop valve 50 and the first interface 109, the low-pressure gas join the low-pressure gas output via the four-way valve 102.

[0041] As shown in Fig. 9, when the outdoor unit 10 determines that the multi-split system works under a pure cooling mode, the four indoor units perform cooling work. The flow direction of a refrigerant will be described as follows: a high-pressure gas flows into the four-way valve 102 via the oil separator 105 from the exhaust port of the compressor 101, then turns into a high-pressure liquid after flowing through the outdoor heat exchanger 103; and after flowing through the electronic expansion valve 112, the second interface 110 and the high-pressure stop valve 40, the high-pressure liquid turns into a four-way low-pressure gas-liquid two-phase refrigerant after flowing through the throttling elements in the four indoor units respectively; and the four-way low-pressure gas-liquid two-phase refrigerant turns into a four-way low-pressure gas after flowing through the corresponding indoor heat exchangers respectively, and the four-way low-pressure gas flows back to the gas returning port of the compressor 101 via the four first controlling valves 302A, 302B, 302C, 302D, the low-pressure stop valve 50, the first interface 109, and the outdoor gas-liquid separator 104.

[0042] As shown in Fig. 10, when the outdoor unit 10 determines that the multi-split system works under a main cooling mode, three of the four indoor units perform cooling work and one indoor unit performs heating work. The flow direction of a refrigerant for cooling will be described as follows: after a high-pressure gas flowing through the oil separator 105 from the exhaust port of the compressor 101, a part of the high-pressure gas flows into the four-way valve 102, then turns into a high-pressure liquid after flowing through the outdoor heat exchanger 103, and the high-pressure liquid flows into the throttling elements in the three indoor units via the electronic expansion valve 112, the second interface 110 and the high-pressure stop valve 40, and the high-pressure liquid turns into a low-pressure gas-liquid two-phase refrigerant via the throttling element, and then further turns into a three-way low-

pressure gas via the indoor heat exchangers in the three indoor units, and the three-way low-pressure gas flows back to the gas returning port of the compressor 101 correspondingly via the three first controlling valves 302A, 302B, 302C, the low-pressure stop valve 50, the first interface 109 and the outdoor gas-liquid separator 104. The flow direction of a refrigerant for heating will be described as follows: the other part of the high-pressure gas flowing through the oil separator 105 flows into the four-way valve 102A, the third interface 111, the stop valve 60, the second controlling valve 303D, then flows into the indoor heat exchanger 241 in the indoor unit 24 to turns into a high-pressure liquid; and after flowing through the throttling element 242 in the indoor unit 24, the high-pressure liquid joins the high-pressure liquid flowing through the high-pressure stop valve 40.

[0043] In embodiments of the present disclosure, each indoor unit needs to send an operating parameter of the indoor unit to the distribution device 30, in which the operating parameter of each indoor unit includes: an operating mode of the indoor unit (such as a cooling mode, a heating mode, etc.), a superheat degree when the indoor unit serves as a cooling indoor unit and an opening of the throttling element when the indoor unit serves as a cooling indoor unit, etc.

[0044] According to an embodiment of the present disclosure, as shown in Fig. 11, the outdoor unit and the distribution device may communicate with each other directly, and each indoor unit communicates with the outdoor unit through the distribution device. Each indoor unit is allocated with an address for convenience for the communications between individual indoor units and communications between each indoor unit and the distribution device, for example, the first indoor unit is allocated with a first address, and the second indoor unit is allocated with a second address, ..., and the seventh indoor unit is allocated with a seventh address. In addition, each indoor unit further includes a wired controller, and each indoor unit further communicates with a respective wired controller.

[0045] Further, according to a specific example of the present disclosure, the outdoor controller in the outdoor unit communicates with the control module in the distribution device, meanwhile, the control module in the distribution device communicates with the indoor controllers in each indoor unit. The outdoor controller in the outdoor unit acquires temperature information of the outdoor unit (such as a temperature of the environment in which the outdoor unit is located, an exhausting temperature, a gas returning temperature, a heat exchange temperature, etc.), pressure information (such as an exhausting pressure, a gas returning pressure, etc.) and operating modes of each indoor unit sent by a plurality of indoor units and so on in real time to determine an operating mode of the multi-split system (such as a pure heating mode, a main heating mode, a pure cooling mode and a main cooling mode), and sends the instruction indicating the operating mode of the multi-split system to the distribution device.

Meanwhile, the outdoor controller in the outdoor unit further controls the compressor and the outdoor fan, etc. to operate according to the inner logic output instruction signal.

[0046] Specifically, after the multi-split system is turned on, the outdoor controller in the outdoor unit acquires environment temperature information, pressure information of the outdoor unit and operating modes of each indoor unit to determine an operating mode of the multi-split system. For example, when each indoor unit operates under a cooling mode, the operating mode of the multi-split system is a pure cooling mode; when each indoor unit operates under a heating mode, the operating mode of the multi-split system is a pure heating mode; when there are both indoor units operating under a cooling mode and indoor units operating under a heating mode in the plurality of indoor units, the operating mode of the multi-split system is a simultaneous cooling and heating mode, and the outdoor unit sends corresponding mode instruction to the distribution device according to the determined operating mode of the system. Meanwhile, the outdoor unit controls the compressor and the outdoor fan, etc. to operate according to the inner logic output instruction signal. The distribution device controls each status parameter according to the mode instruction given by the outdoor unit.

[0047] Moreover, after the multi-split system starts operating, when a user performs a mode switching on the indoor unit, the indoor unit to perform a mode switching sends the switched operating mode to the distribution device 30, and the distribution device 30 determines the opening or closing of a plurality of first controlling valves (such as the four first controlling valves 302A, 302B, 302C, 302D) and a plurality of second controlling valves (such as the four second controlling valves 303A, 303B, 303C, 303D) according to the switched operating mode.

[0048] Next, a specific description will be made by taking the indoor unit 24 as an example.

[0049] When the indoor unit 24 is under a cooling operating mode, as shown in Fig. 3 (Fig. 8), Fig. 4 (Fig. 9), the distribution device 30 controls the first on/off valve 302D to open and the second on/off valve 303D to close, and the indoor controller automatically controls the opening of the throttling element 242. When the indoor unit 24 receives an instruction sent by the user indicating switching to a heating operating mode, the distribution device 30 controls the first on/off valve 302D to close first, and the indoor controller controls the opening of the throttling element 242 to reach 480P. After 60 seconds, the distribution device 30 controls the second on/off valve 303D to open as shown in Fig. 2 (Fig. 7), Fig. 5 (Fig. 10), and thus the indoor unit 24 completes a switch to a heating operating mode from a cooling operating mode.

[0050] When the indoor unit 24 is under a heating operating mode, as shown in Fig. 2 (Fig. 7), Fig. 5 (Fig. 10), the distribution device 30 controls the first on/off valve 302D to close and the second on/off valve 303D to open, and the indoor controller automatically controls the open-

ing of the throttling element 242. When the indoor unit 24 receives an instruction sent by the user indicating switching to a cooling operating mode, the distribution device 30 controls the second on/off valve 303D to close, and the indoor controller controls the opening of the throttling element 242 to reach 72P for 30 seconds. Then, the indoor controller controls the opening of the throttling element 242 to reach 480P so as to make the indoor unit 24 be filled with a medium-pressure liquid refrigerant. After 60 seconds, the distribution device 30 controls the first on/off valve 302D to open again as shown in Fig. 3 (Fig. 8), Fig. 4 (Fig. 9), and thus the indoor unit 24 completes a switch to a cooling operating mode from a heating operating mode.

[0051] In addition, in embodiments of the present disclosure, when any one of the plurality of indoor units is under a cooling operating mode, the indoor unit may be controlled to be switched to a cooling standby mode, a cooling stopping mode or a heating operating mode; when any one of the plurality of indoor units is under a cooling standby mode, the indoor unit may be controlled to be switched to a cooling stopping mode or a heating operating mode; when any one of the plurality of indoor units is under a cooling stopping mode, the indoor unit may be controlled to be switched to a cooling operating mode or a heating operating mode; when any one of the plurality of indoor units is under a heating operating mode, the indoor unit may be controlled to be switched to a heating standby mode, a heating stopping mode or a cooling operating mode; when any one of the plurality of indoor units is under a heating standby mode, the indoor unit may be controlled to be switched to a heating stopping mode or a cooling operating mode; when any one of the plurality of indoor units is under a heating stopping mode, the indoor unit may be controlled to be switched to a cooling operating mode or a heating operating mode.

[0052] Specifically, when any one of the plurality of indoor units operates under a cooling mode, when a cooling standby mode or a cooling stopping mode sent by the user through a wired controller is received, none of the first controlling valve and the second controlling valve in the distribution device 30 operates, and the indoor controller in the indoor unit controls the opening of the throttling element to close after being maintained for 30 seconds.

[0053] When any one of the plurality of indoor units operates under a cooling mode, when a heating mode sent by the user through a wired controller is received, after receiving a heating start signal, the shunt apparatus 30 closes the first controlling valve corresponding to the indoor unit, and the indoor controller in the indoor unit controls the opening of the throttling element to close after being maintained for 30 seconds, then controls the opening of the throttling element to reach 480P and to be maintained at 480P for 60 seconds, closes the opening of the throttling element to an initial opening after 60 seconds, then performs adjustment according to PI. Ad-

ditionally, after receiving the heating start signal for 105 seconds, the distribution device 30 opens the second controlling valve.

[0054] Switches between operating modes of other indoor units will not be described again here. In conclusion, in embodiments of the present disclosure, the distribution device 30 determines on or off statuses of the first on/off valve and the second on/off valve corresponding to the indoor unit according to a mode switching instruction, meanwhile the indoor controller in the indoor unit controls the opening of the throttling element according to the mode switching instruction so as to reduce the noise during the mode switching process.

[0055] By the multi-split system according to embodiments of the present disclosure, when any one of the plurality of indoor units receives a mode switching instruction, the indoor unit sends the mode switching instruction to a distribution device such that the distribution device determines on or off statuses of the first on/off valve and the second on/off valve corresponding to the indoor unit according to the mode switching instruction so as to ensure a small pressure difference between the front and back of the on/off valve when the indoor unit switches the mode, and thus noises generated due to a big pressure difference in the mode switching process may be effectively reduced, and the comfort level of users may be improved.

[0056] In the description of the present disclosure, it is to be understood that terms such as "central," "longitudinal," "lateral," "length," "width," "thickness," "upper," "lower," "front," "rear," "left," "right," "vertical," "horizontal," "top," "bottom," "inner," "outer," "clockwise," "counterclockwise," "axial," "radial" and "peripheral" should be construed to refer to the orientation as then described or as shown in the drawings under discussion. These relative terms are for convenience of description and do not require that the present invention be constructed or operated in a particular orientation, therefore cannot be construed to limit the present disclosure.

[0057] In addition, terms such as "first" and "second" are used herein for purposes of description and are not intended to indicate or imply relative importance or significance or to imply the number of indicated technical features. Thus, the feature defined with "first" and "second" may explicitly or implicitly comprises one or more of this feature. In the description of the present disclosure, "a plurality of" means two or more than two, unless specified otherwise.

[0058] In the present disclosure, unless specified or limited otherwise, the terms "mounted," "connected," "coupled," "fixed" and the like are used broadly, and may be, for example, fixed connections, detachable connections, or integral connections; may also be mechanical or electrical connections; may also be direct connections or indirect connections via intervening structures; may also be inner communications of two elements, which can be understood by those skilled in the art according to specific situations.

[0059] In the present disclosure, unless specified or limited otherwise, a structure in which a first feature is "on" or "below" a second feature may include an embodiment in which the first feature is in direct contact with the second feature, and may also include an embodiment in which the first feature and the second feature are not in direct contact with each other, but are contacted via an additional feature formed therebetween. Furthermore, a first feature "on," "above," or "on top of" a second feature may include an embodiment in which the first feature is right or obliquely "on," "above," or "on top of" the second feature, or just means that the first feature is at a height higher than that of the second feature; while a first feature "below," "under," or "on bottom of" a second feature may include an embodiment in which the first feature is right or obliquely "below," "under," or "on bottom of" the second feature, or just means that the first feature is at a height lower than that of the second feature.

[0060] Reference throughout this specification to "an embodiment," "some embodiments," "one embodiment," "an example," "a specific example," or "some examples" means that a particular feature, structure, material, or characteristic described in connection with the embodiment or example are included in at least one embodiment or example of the present disclosure. In the specification, expressions of the above terms do not need for same embodiments or examples. Furthermore, the feature, structure, material, or characteristic described can be incorporated in a proper way in any one or more embodiments or examples. In addition, under non-conflicting condition, those skilled in the art can incorporate or combine features described in different embodiments or examples.

[0061] Although explanatory embodiments have been shown and described, it would be appreciated that the above embodiments are exemplary and cannot be construed to limit the present disclosure, and changes, amendments, alternatives and modifications can be made in the embodiments by those skilled in the art without departing from spirit, principles and scope of the present disclosure.

Claims

1. A multi-split system, comprising an outdoor unit, a distribution device, a plurality of indoor units, in which each indoor unit comprises an indoor heat exchanger and a throttling element, and the distribution device comprises a plurality of first controlling valves and a plurality of second controlling valves corresponding to each indoor unit, when any one of the plurality of indoor units receives a mode switching instruction, the indoor unit sends the mode switching instruction to the distribution device; the distribution device determines on or off statuses of a first on/off valve and a second on/off valve corresponding to the indoor unit according to the mode

switching instruction.

2. The multi-split system according to claim 1, wherein when any one of the plurality of indoor units is under a heating operating mode, the distribution device controls the second on/off valve corresponding to the indoor unit to open, and controls the first on/off valve corresponding to the indoor unit to close, and controls an opening of the throttling element in the indoor unit by an indoor controller in the indoor unit, in which when the indoor unit receives an instruction indicating switching to a cooling operating mode, the distribution device controls the second on/off valve corresponding to the indoor unit to close, and controls the throttling element in the indoor unit to reach a standby opening by the indoor controller in the indoor unit; the distribution device controls the throttling element in the indoor unit to reach a maximum opening by the indoor controller in the indoor unit after a first preset time so as to make the indoor unit be filled with a medium-pressure liquid refrigerant, the distribution device controls the first on/off valve corresponding to the indoor unit to open after a second preset time, in which the second preset time is longer than the first preset time.
3. The multi-split system according to claim 1, wherein when any one of the plurality of indoor units is under a cooling operating mode, the distribution device controls the first on/off valve corresponding to the indoor unit to open, and controls the second on/off valve corresponding to the indoor unit to close, and controls an opening of the throttling element in the indoor unit by an indoor controller in the indoor unit, in which when the indoor unit receives an instruction indicating switching to a heating operating mode, the distribution device controls the first on/off valve corresponding to the indoor unit to close, and controls the throttling element in the indoor unit to reach a maximum opening by the indoor controller in the indoor unit; the distribution device controls the second on/off valve corresponding to the indoor unit to open after a second preset time.
4. The multi-split system according to any one of claims 1-3, wherein the multi-split system comprises a two-pipe heat recovery multi-split system and a three-pipe heat recovery multi-split system.
5. The multi-split system according to claim 1, wherein when any one of the plurality of indoor units is under a cooling operating mode, the indoor unit may be controlled to be switched to a cooling standby mode, a cooling stopping mode or a heating operating mode; when any one of the plurality of indoor units is under

a cooling standby mode, the indoor unit may be controlled to be switched to a cooling stopping mode or a heating operating mode;
 when any one of the plurality of indoor units is under a cooling stopping mode, the indoor unit may be controlled to be switched to a cooling operating mode or a heating operating mode;
 when any one of the plurality of indoor units is under a heating operating mode, the indoor unit may be controlled to be switched to a heating standby mode, a heating stopping mode or a cooling operating mode;
 when any one of the plurality of indoor units is under a heating standby mode, the indoor unit may be controlled to be switched to a heating stopping mode or a cooling operating mode;
 when any one of the plurality of indoor units is under a heating stopping mode, the indoor unit may be controlled to be switched to a cooling operating mode or a heating operating mode.

5

10

15

20

6. The multi-split system according to claim 2 or 3, wherein the first preset time is in a range of 20 to 40 seconds, and the second preset time is in a range of 50 to 70 seconds.

25

7. The multi-split system according to claim 2, wherein the standby opening is 72P, and the maximum opening is 480P.

30

35

40

45

50

55

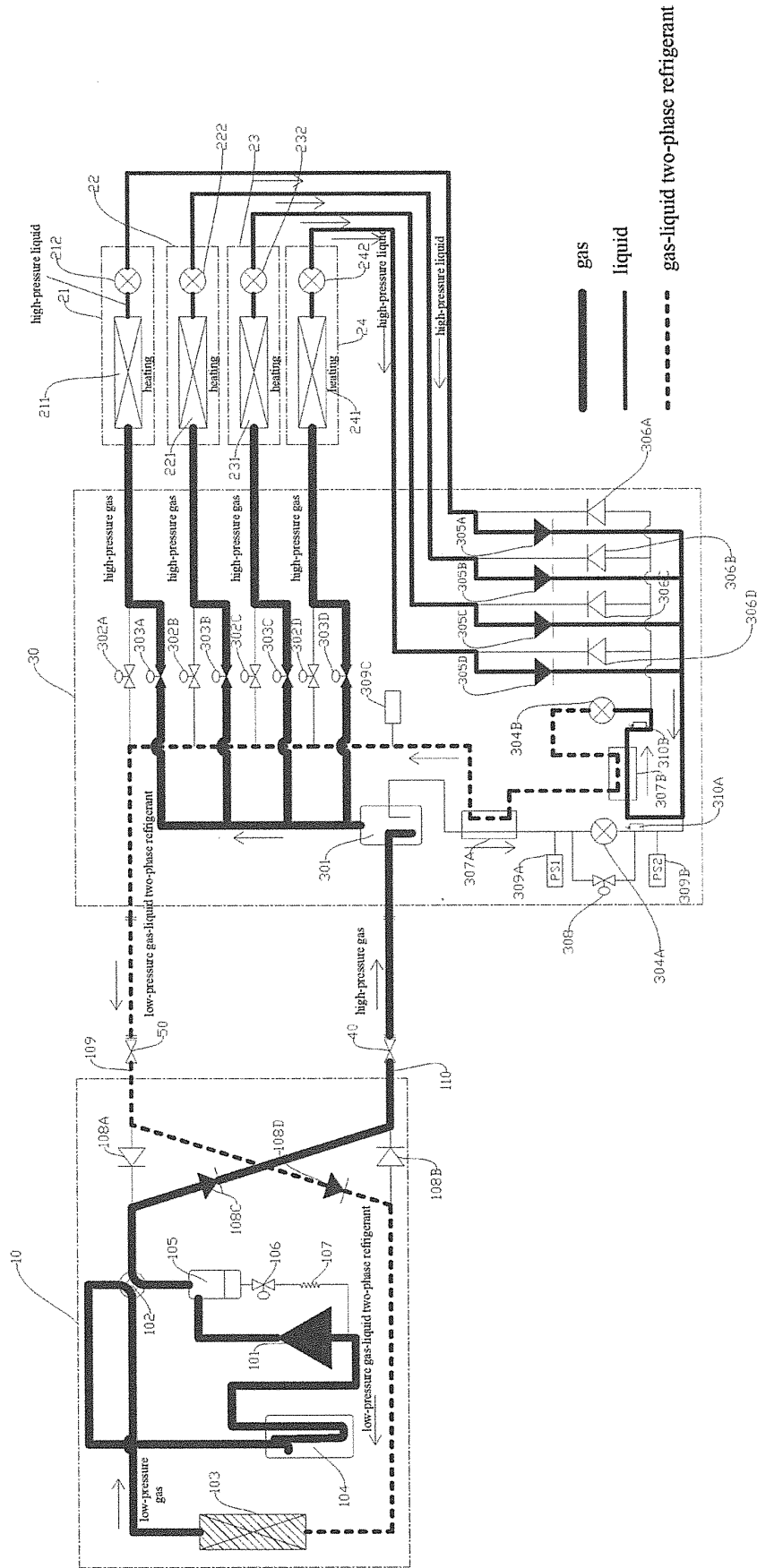

Fig. 2

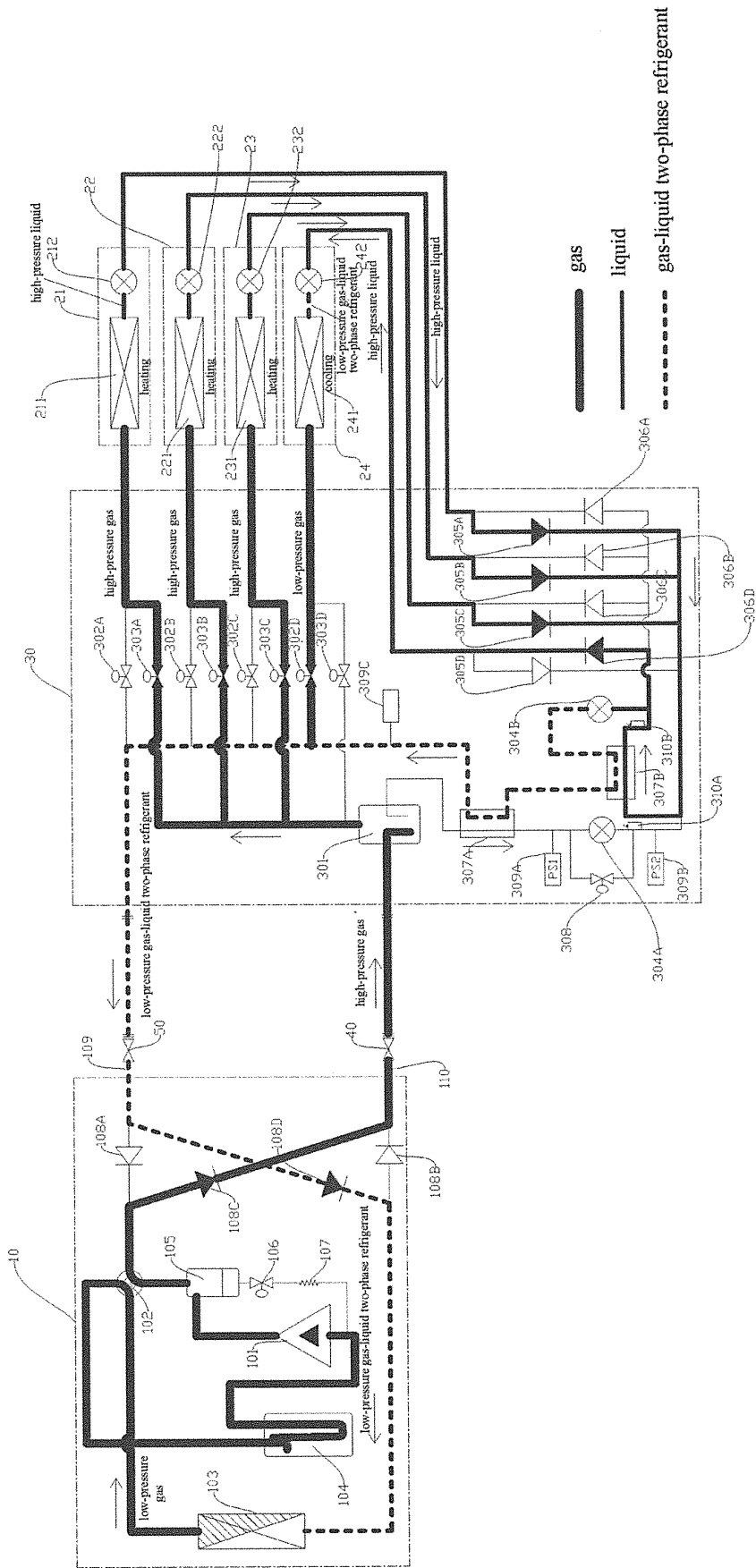

Fig. 3

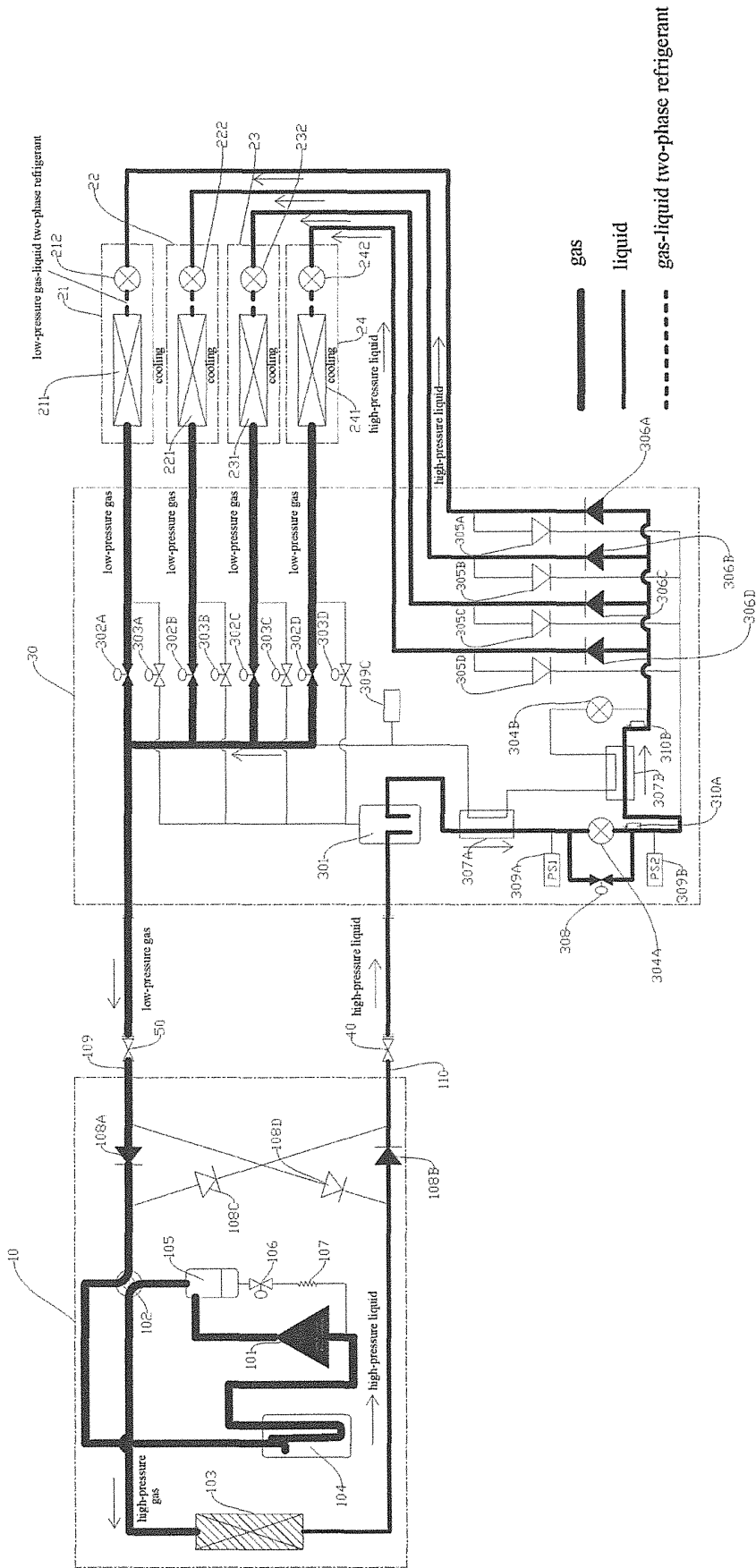

Fig. 4

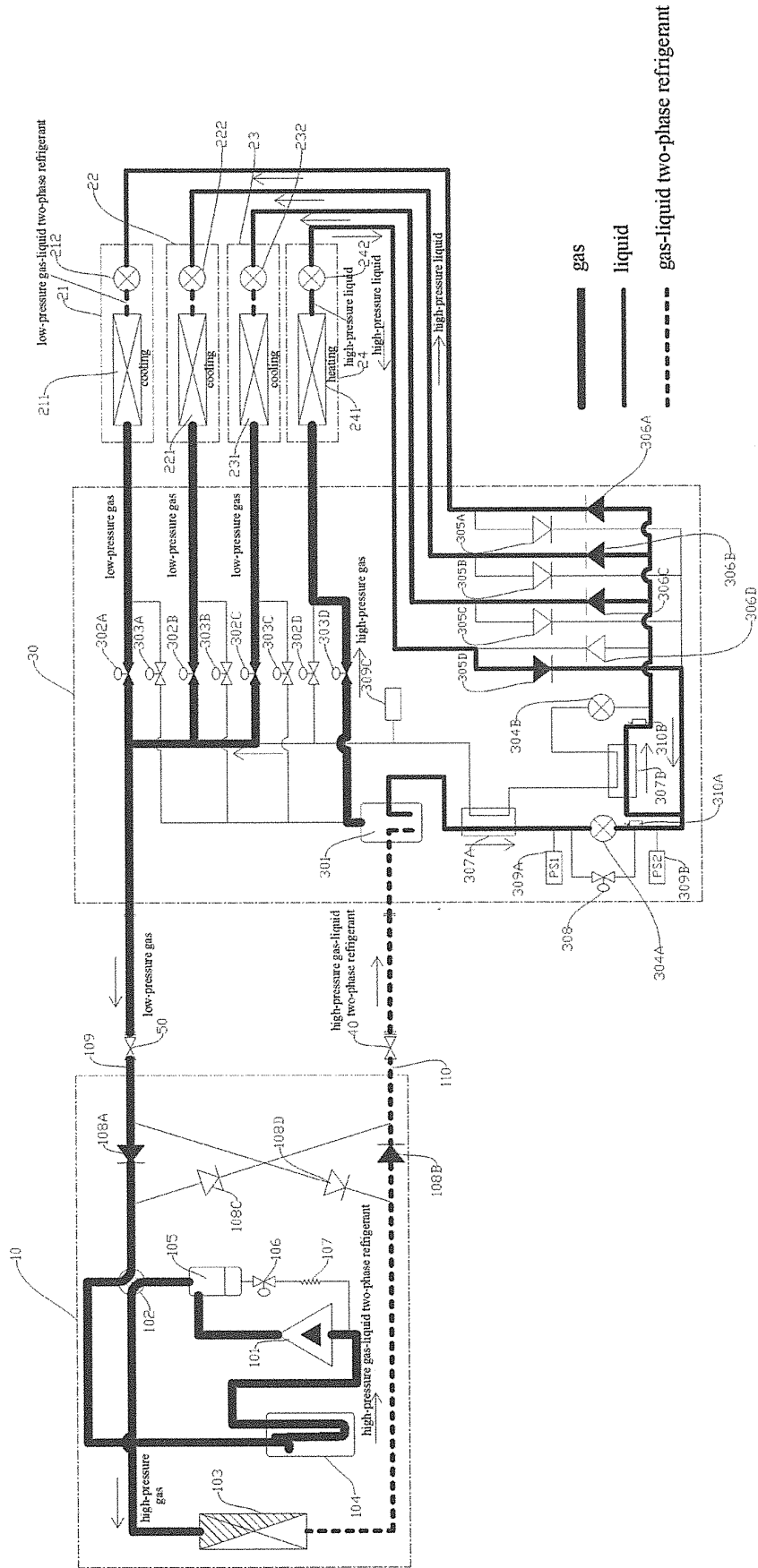

Fig. 5

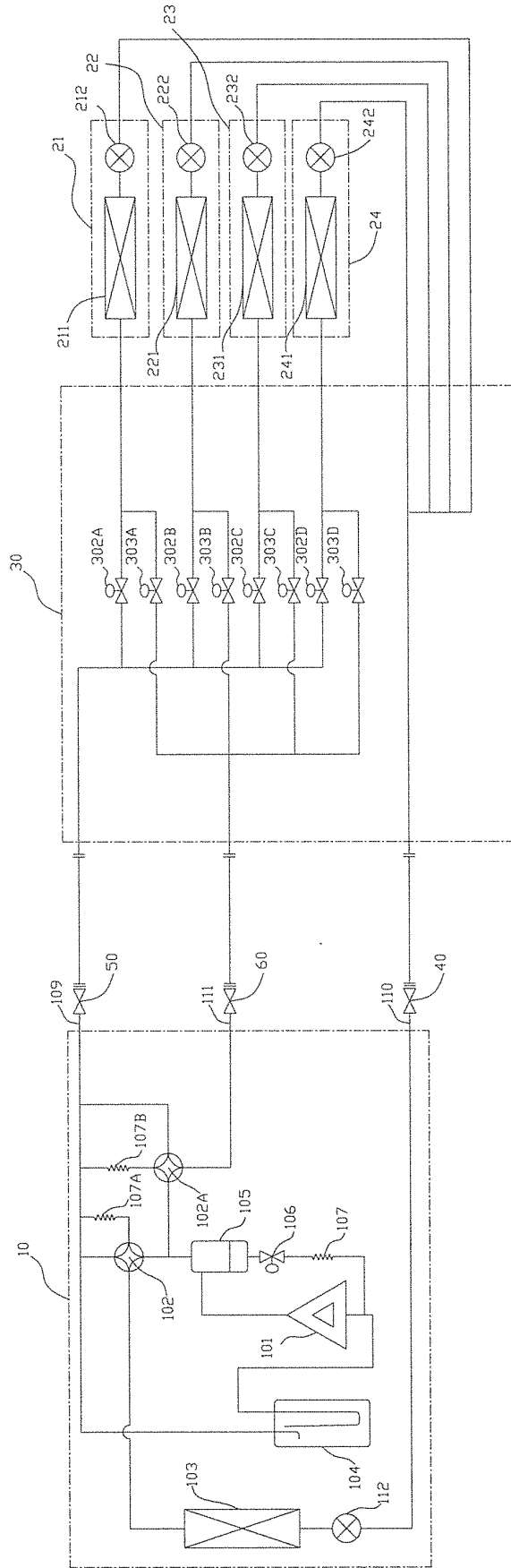

Fig. 6

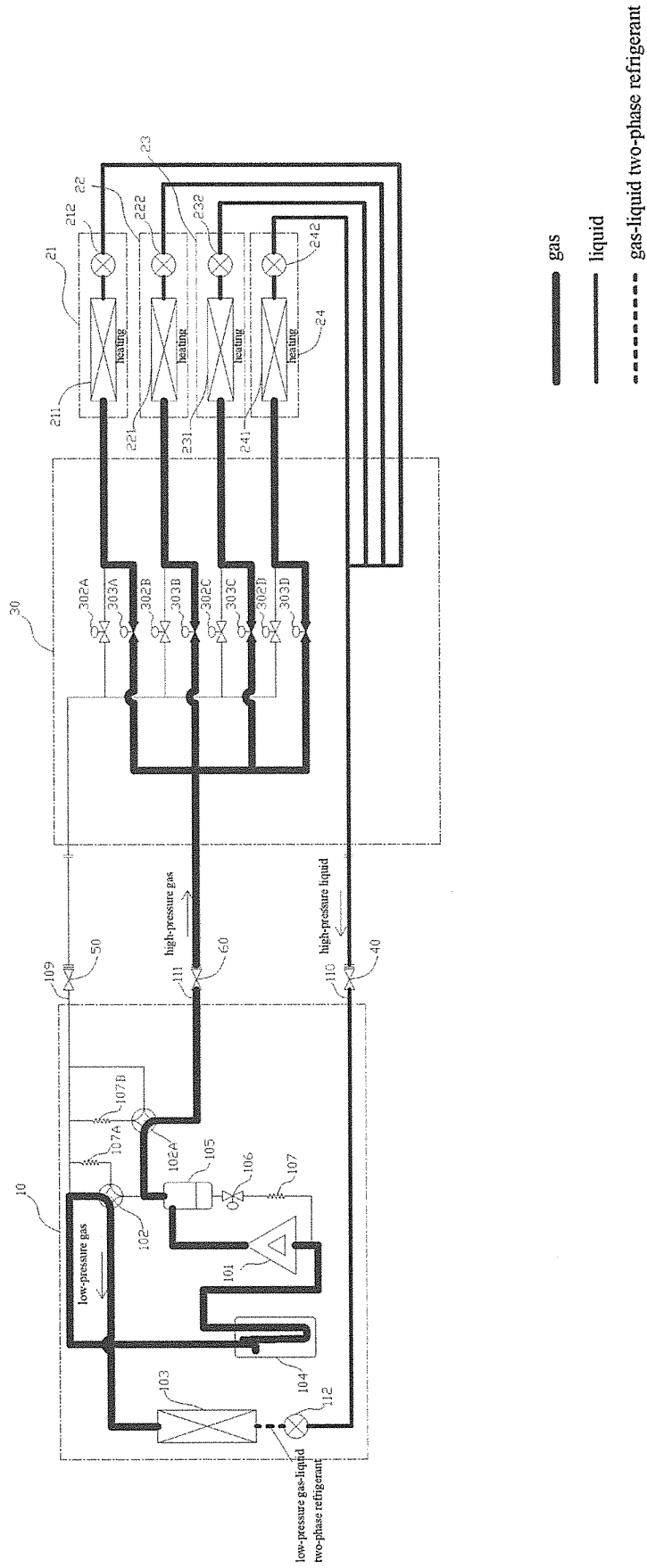

Fig. 7

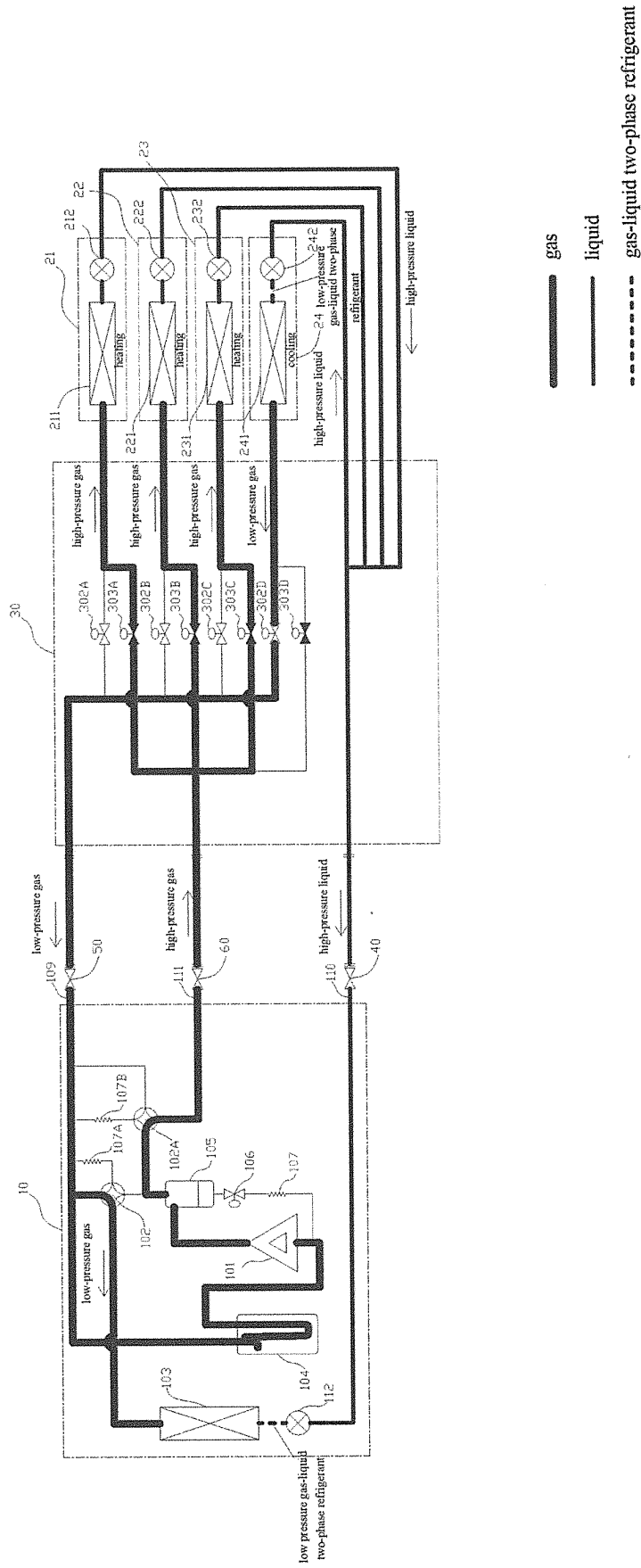

Fig. 8

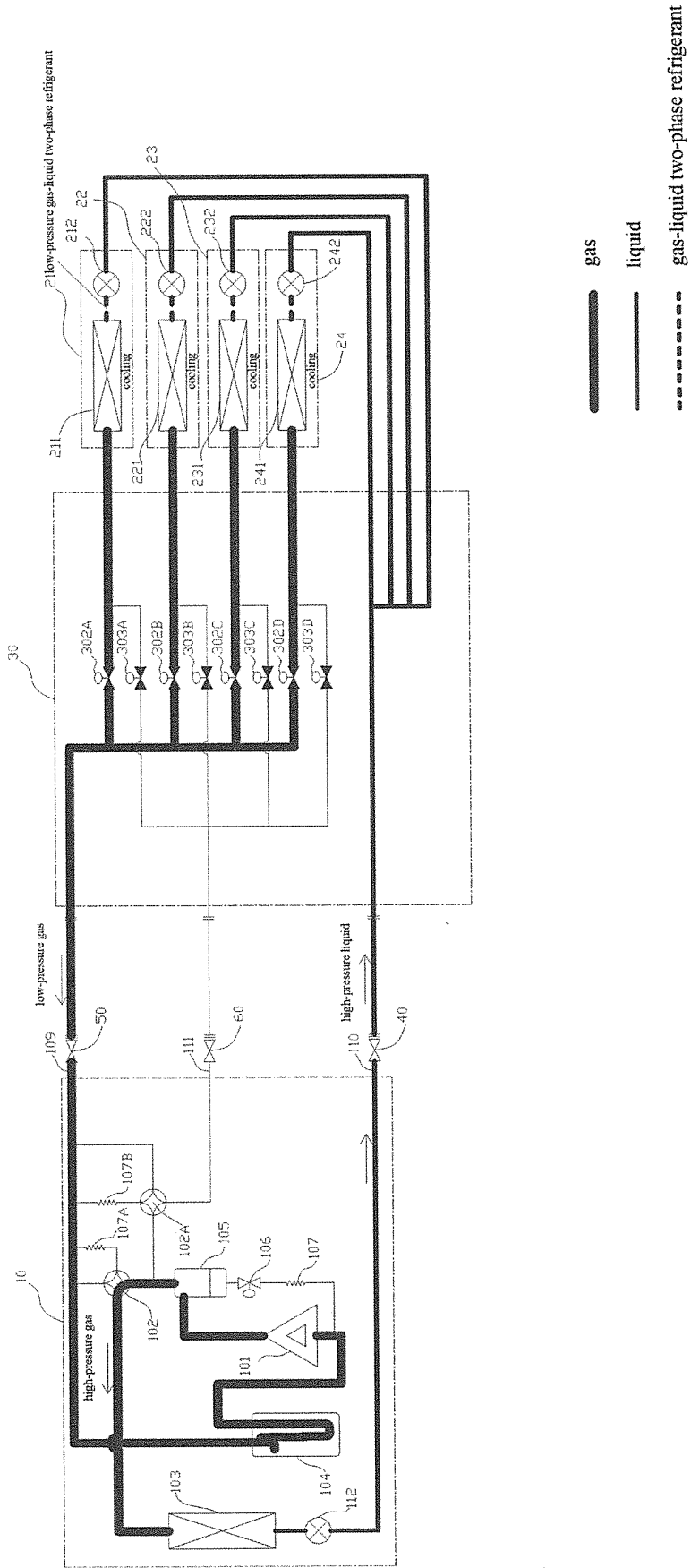

Fig. 9

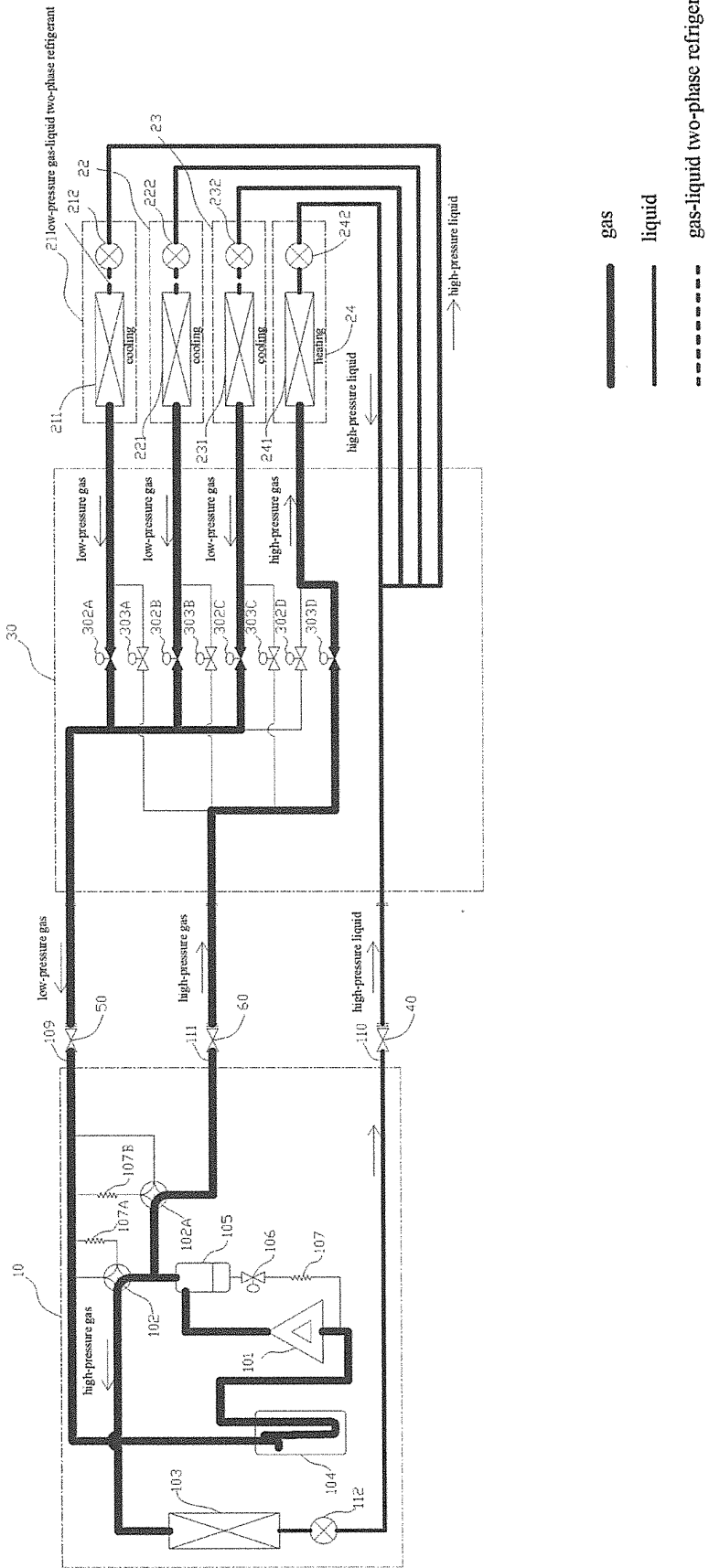

Fig. 10

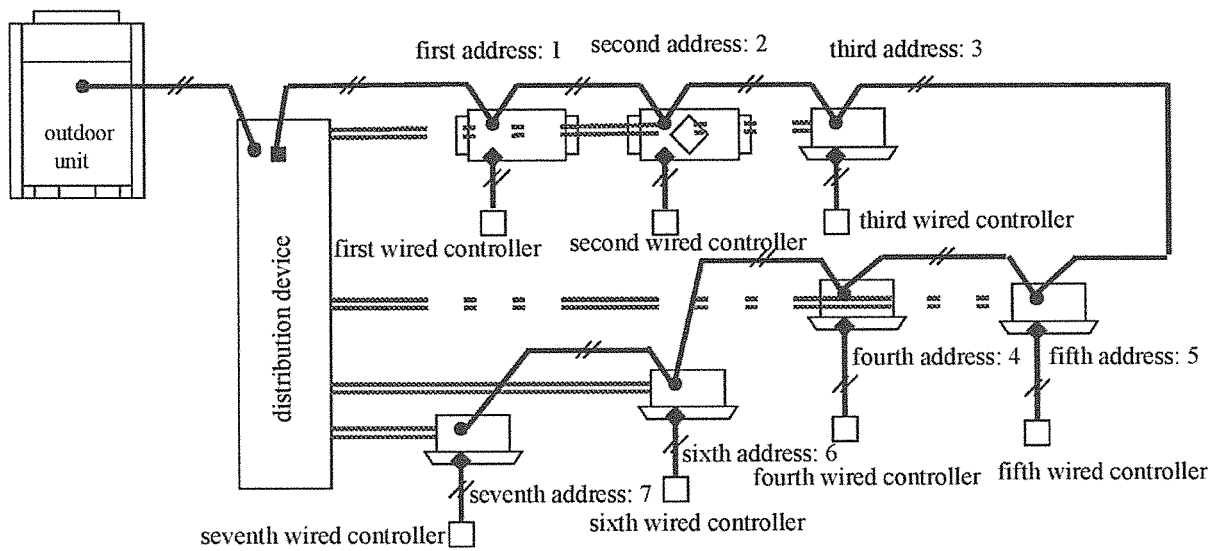

Fig. 11

INTERNATIONAL SEARCH REPORT

International application No.

PCT/CN2015/098290

A. CLASSIFICATION OF SUBJECT MATTER

F24F 3/06 (2006.01) i; F24F 11/02 (2006.01) n; F25B 41/04 (2006.01) n; F25B 49/02 (2006.01) n
According to International Patent Classification (IPC) or to both national classification and IPC

B. FIELDS SEARCHED

Minimum documentation searched (classification system followed by classification symbols)

F24F; F25B

Documentation searched other than minimum documentation to the extent that such documents are included in the fields searched

Electronic data base consulted during the international search (name of data base and, where practicable, search terms used)

CNABS, CNPAT, CNKI, DWPI, SIPOABS, EPODOC: multi-couple, multi-couple unit, multiply-connecting, heat pump, working condition, moment, duration, MULTI+, CONNECT+, REFRIGERAT+, HEAT+, PUMP, MODE, CONDITION, SWITCH+, TIME, SECOND, MINUTE, NOISE, EXPAN+, THROTTLE, OPEN+

C. DOCUMENTS CONSIDERED TO BE RELEVANT

Category*	Citation of document, with indication, where appropriate, of the relevant passages	Relevant to claim No.
X	CN 203249455 U (MITSUBISHI ELECTRIC CORPORATION), 23 October 2013 (23.10.2013), description, paragraphs [0038]-[0280], and figures 1-11	1, 4-5
PX	CN 104748239 A (GUANGDONG MIDEA HEATING & VENTILATION EQUIPMENT CO., LTD. et al.), 01 July 2015 (01.07.2015), claims 1-7	1-7
A	CN 104364591 A (MITSUBISHI ELECTRIC CORPORATION), 18 February 2015 (18.02.2015), the whole document	1-7
A	CN 103917834 A (MITSUBISHI ELECTRIC CORPORATION), 09 July 2014 (09.07.2014), the whole document	1-7
A	JP 2005180751 A (MITSUBISHI JUKOGYO KK), 07 July 2005 (07.07.2005), the whole document	1-7

Further documents are listed in the continuation of Box C. See patent family annex.

* Special categories of cited documents:	“T” later document published after the international filing date or priority date and not in conflict with the application but cited to understand the principle or theory underlying the invention
“A” document defining the general state of the art which is not considered to be of particular relevance	“X” document of particular relevance; the claimed invention cannot be considered novel or cannot be considered to involve an inventive step when the document is taken alone
“E” earlier application or patent but published on or after the international filing date	“Y” document of particular relevance; the claimed invention cannot be considered to involve an inventive step when the document is combined with one or more other such documents, such combination being obvious to a person skilled in the art
“L” document which may throw doubts on priority claim(s) or which is cited to establish the publication date of another citation or other special reason (as specified)	“&” document member of the same patent family
“O” document referring to an oral disclosure, use, exhibition or other means	
“P” document published prior to the international filing date but later than the priority date claimed	

Date of the actual completion of the international search 09 March 2016 (09.03.2016)	Date of mailing of the international search report 29 March 2016 (29.03.2016)
Name and mailing address of the ISA/CN: State Intellectual Property Office of the P. R. China No. 6, Xitucheng Road, Jimenqiao Haidian District, Beijing 100088, China Facsimile No.: (86-10) 62019451	Authorized officer XIANG, Changsong Telephone No.: (86-10) 62084757

INTERNATIONAL SEARCH REPORT
Information on patent family members

International application No.

PCT/CN2015/098290

5	Patent Documents referred in the Report	Publication Date	Patent Family	Publication Date
	CN 203249455 U	23 October 2013	EP 2833086 A1	04 February 2015
			US 2015034293 A1	05 February 2015
10			WO 2013144994 A1	03 October 2013
			EP 2833086 A4	02 December 2015
	CN 104748239 A	01 July 2015	None	
	CN 104364591 A	18 February 2015	WO 2013179334 A1	05 December 2013
15			EP 2863152 A1	22 April 2015
			US 2015176879 A1	25 June 2015
			JP WO2013179334	14 January 2016
	CN 103917834 A	09 July 2014	CN 103917834 B	16 December 2015
20			AU 2011380810 B2	16 April 2015
			EP 2778567 A1	17 September 2014
			WO 2013069044 A1	16 May 2013
			EP 2778567 A4	08 July 2015
25			AU 2011380810 A1	03 April 2014
			US 2014182329 A1	03 July 2014
			JP 5774121 B2	02 September 2015
			JP WO2013069044 A1	02 April 2015
30	JP 2005180751 A	07 July 2005	JP 4427310 B2	03 March 2010
35				
40				
45				
50				
55				

Form PCT/ISA/210 (patent family annex) (July 2009)