

(19)



(11)

EP 3 282 525 A1

(12)

EUROPEAN PATENT APPLICATION

(43) Date of publication:
14.02.2018 Bulletin 2018/07

(51) Int Cl.:
H01R 13/66 (2006.01) H01R 24/64 (2011.01)
H01R 12/55 (2011.01) H01R 24/62 (2011.01)

(21) Application number: **17187459.7**

(22) Date of filing: **11.04.2012**

(84) Designated Contracting States:
AL AT BE BG CH CY CZ DE DK EE ES FI FR GB GR HR HU IE IS IT LI LT LU LV MC MK MT NL NO PL PT RO RS SE SI SK SM TR

- **Miller, Allen Michael**
Lenoir, North Carolina 28645 (US)
- **Schulte, Martin**
15745 Wildau (DE)

(30) Priority: **20.04.2011 DE 202011005469 U**

(74) Representative: **Sturm, Christoph**
Quermann Sturm Weilnau
Patentanwälte Partnerschaft mbB
Unter den Eichen 5
65195 Wiesbaden (DE)

(62) Document number(s) of the earlier application(s) in accordance with Art. 76 EPC:
12163779.7 / 2 515 389

(71) Applicant: **CCS Technology Inc.**
Wilmington, DE 19803 (US)

Remarks:

This application was filed on 23-08-2017 as a divisional application to the application mentioned under INID code 62.

(72) Inventors:
• **Matthies, Jürgen**
58300 Wetter (DE)

(54) **ELECTRICAL PLUG-TYPE CONNECTOR**

(57) Electrical plug-type connector, namely data jack for receiving, in contact-making fashion, at least one data plug, with a housing and with a connecting device positioned in the housing, the connecting device having a printed circuit board (10) with electrical conductors, the connecting device furthermore having contact springs (11, 12, 13, 14, 15, 16, 17, 18), via which contact can be made between the conductors of the printed circuit board (10) and contacts of a data plug, the contact springs being anchored, at a first section (19) thereof, in the printed circuit board and permanent contact thus being made

between said contact springs and the conductors of said printed circuit board, it being possible for contact to be made between the contact springs, via a second, elastically deformable section (20), and the contacts of a data plug. The second, elastically deformable section (20) of the contact springs (11, 12, 13, 14, 15, 16, 17, 18) has two subsections (27, 28), which are inclined differently with respect to a horizontal or the insertion direction of the data plug, the two subsections (27, 28) enclosing an angle ($\Delta\beta$) of between 35° and 45° in the load-free state of the contact springs (11, 12, 13, 14, 15, 16, 17, 18).

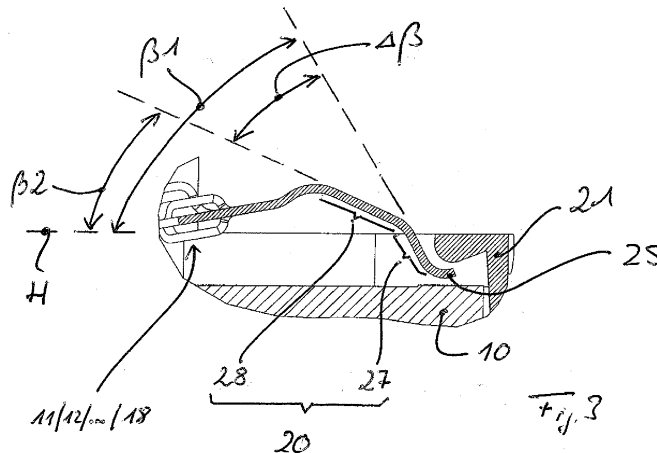

EP 3 282 525 A1

Description

[0001] This application claims the benefit of priority to German Utility Model No. 202011005469.1, filed 20 April 2011.

[0002] The disclosure relates to an electrical plug-type connector in accordance with the preamble of Claim 1.

[0003] US 6,530,810 B2 has disclosed an electrical plug-type connector in the form of a data jack, said plug-type connector having a housing and a connecting device positioned in the housing. The housing is formed by a plurality of sections, inter alia by a front housing section, into which a data plug can be inserted so as to make contact with the connecting device, and by a rear housing section, via which a data cable can be led up to the connecting device positioned in the housing. The connecting device of the electrical plug-type connector known from US 6,530,810 B2 has a printed circuit board and contact springs. If a data plug is inserted, with its contacts, into the data jack, contact is made between the contacts of the data plug, via the contact springs of the connecting device, and conductors provided by the printed circuit board.

[0004] In accordance with US 6,530,810 B2, the contact springs are anchored fixedly, via first sections thereof, in the printed circuit board and thus permanent contact is made between said contact springs and the conductors of the printed circuit board. Contact can be made between the contact springs, via second, elastically deformable sections thereof, and contacts of a data plug which is intended to be received in contact-making fashion by the data jack. In accordance with US 6,530,810 B2, free ends of the contact springs, which adjoin the second sections thereof, bear against a contact holder of the housing when there is no data plug in the data jack, with the result that said contact springs are therefore subjected to a prestress and thus to mechanical loading even when there is no data plug in the data jack.

[0005] When there is a data plug in the data jack, the free ends of the contact springs need to be released by the contact holder counter to this prestress or mechanical loading, as a result of which relatively high stresses are produced in the contact springs. In this case, the contact springs of the data jack can then become damaged.

[0006] There is the need for an electrical plug-type connector, namely a data jack for receiving, in contact-making fashion, at least one data plug, in which the risk of damage to the contact springs is reduced.

[0007] Against this background, the present disclosure is based on the object of providing a novel electrical plug-type connector.

[0008] This object is achieved in accordance with the disclosure by an electrical plug-type connector according to Claim 1. The second, elastically deformable section of the contact springs has two subsections, which are inclined differently with respect to a horizontal or the insertion direction of the data plug, the two subsections enclosing an angle of between 35° and 45° in the load-

free state of the contact springs.

[0009] The disclosure proposes a defined contouring of the second, elastically deformable section of the contact springs, as a result of which plugging forces during insertion of a data plug into the data jack and therefore likewise the stresses in the contact springs can be reduced.

[0010] Preferably, at least some contact springs are free of any load when there is no data plug in the data jack. By virtue of the fact that at least some of the contact springs are free of load when there is no data plug in the data jack, stresses in the respective contact spring during insertion of a data plug into the data jack are reduced.

[0011] Preferably, the contact springs have a portion of thickened material adjacent to the first sections of said contact springs sectionally. The strength of the contact springs is likewise increased, as a result of which the risk of damage to said contact springs during insertion of a data plug into the data jack is also reduced.

[0012] With the present disclosure, the risk of damage to the contact springs of the data jack during insertion of a data plug into said data jack can be reduced.

[0013] Preferred developments of the disclosure can be gleaned from the dependent claims and the description below. Exemplary embodiments of the disclosure are explained in more detail, without there being any restriction to said embodiments, with reference to the drawing, in which:

- Figure 1 shows a perspective view from above of a detail of an electrical plug-type connector according to the disclosure;
- Figure 2 shows a perspective view from below of a detail of an electrical plug-type connector according to the disclosure;
- Figure 3 shows a detail of a cross section through an electrical plug-type connector according to the disclosure in a first state;
- Figure 4 shows the detail of the cross section shown in Figure 3 in a second state; and
- Figure 5 shows a detail of a contact spring of the electrical plug-type connector according to the disclosure.

[0014] The present disclosure relates to an electrical plug-type connector, namely a data jack for receiving, in contact-making fashion, at least one data plug. Such an electrical plug-type connector has a housing, a connecting device being positioned in the housing. The connecting device is used for making contact between contacts of a data plug which has been inserted into the data jack and electrical conductors or line paths of the data jack or data conductors of a data cable, with which contact is likewise made using the connecting device of the data jack.

[0015] The connecting device of the electrical plug-type connector has a printed circuit board 10 (see Figure 1) and contact springs 11, 12, 13, 14, 15, 16, 17 and 18.

The printed circuit board 10 provides electrical conductors, permanent contact being made between the contact springs 11, 12, 13, 14, 15, 16, 17 and 18, via first sections 19 in the form of bent-back contact eyelets, and the conductors of the printed circuit board 10. Via these first sections 19 in the form of contact eyelets, the contact springs 11 to 18 are anchored in the printed circuit board 10 in order thus to ensure that permanent contact is made between the contact springs 11 to 18 and the conductors of the printed circuit board 10.

[0016] Via second, elastically deformable sections 20 of the contact springs 11 to 18, contact can be made between said contact springs, and thus the connecting device, and contacts of a data plug to be inserted into or accommodated by the data jack in order thus to ensure that detachable contact is made between the contacts of the data plug, via the contact springs 11 to 18, and the conductors of the printed circuit board 10.

[0017] As can best be seen from Figure 2, which shows the contact springs 11 to 18 of the connecting device but not the printed circuit board 10, at least some of the contact springs 11 to 18 cross over one another in a region between the second section 20 and the first section 19 thereof, without coming into touching contact, i.e. the contact springs 11 and 12, the contact springs 17 and 18 and the contact springs 14 and 15, as shown in Figure 2. The contact springs 13 and 16, on the other hand, are guided such that they do not cross over any other contact springs.

[0018] Figures 1 and 2 show a so-called contact holder 21 of the housing of the electrical plug-type connector, said contact holder being used firstly to receive and guide the contact springs 11 to 18 and secondly to receive the printed circuit board 10. A data plug can be inserted into a front section 22 of the contact holder 11, namely whilst making contact between the contacts of the data plug and the second sections 20 of the contact springs 11 to 18.

[0019] A rear section 23 of the contact holder 21 is used for receiving insulation displacement contacts (not shown in Figures 1 and 2), with permanent contact likewise being made between said insulation displacement contacts and the conductors of the printed circuit board 10, and it likewise being possible for said insulation displacement contacts to be connected to the data conductors of a data cable. Figures 1 and 2 show merely cutouts 24 in the region of the section 23 of the contact holder 21 which are used for receiving the insulation displacement contacts, which for their part are used for making contact between the printed circuit board and the data conductors of a data cable.

[0020] At least some contact springs of the contact springs 11 to 18 are free of any load when there is no data plug in the data jack. The contact springs which are free of load when there is no data plug in the data jack are at least all inner or central contact springs 12, 13, 14, 15, 16 and 17, with respect to the free ends 25 thereof.

[0021] These load-free contact springs are character-

ized by the fact that free ends 25 of the respective load-free contact springs which adjoin the respective second section 20 thereof do not bear either against the contact holder 21 of the housing or against the printed circuit board 10 (see Figure 3), but these ends 25 are instead located freely in space when there is no data plug in the data jack. It thus follows directly from Figure 3 that the shown end 25 of the load-free contact springs shown is located freely in space without coming into touching contact with the contact holder 21 and the printed circuit board 10.

[0022] Such a load-free contact spring is completely free of load and therefore free of stress when there is no data plug in the data jack, with the result that, when contact is made between a data plug 26 (Figure 4) and the data jack or the contact springs 11 to 18 thereof, reduced stresses occur in the contact springs, with the result that a risk of damage to the contact springs during insertion of a data plug into the data jack is reduced.

[0023] As already mentioned, at least all inner and central contact springs 12, 13, 14, 15, 16 and 17, with respect to their free ends 25, are free of any load, specifically when there is no data plug in the data jack, wherein, in accordance with a first, advantageous development, the two outer contact springs 11 and 18, with respect to their free ends 25, are free of any load in this way. In this case, all of the contact springs 11 to 18 are then free of any load when there is no data plug in the data jack.

[0024] In contrast to this, it is also possible for the two outer contact springs 11 and 18, with respect to their free ends 25, to not be free of load, but rather to bear against the contact holder 21 under prestress, when there is no data plug in the data jack, in contrast to the central contact springs 12 to 17.

[0025] This is the case in particular when the printed circuit board 10, which is positioned beneath the contact springs 11 to 18 in Figures 3 and 4, does not extend over all of the contact springs 11 to 18, but only over the load-free contact springs 12 to 17 and not over the non-load-free contact springs 11 and 18.

[0026] In any case, however, owing to the fact that at least six of the eight contact springs 11 to 18 shown in Figures 1 and 2 are free of load when there is no data plug in the data jack, the stresses in the contact springs when there is a data plug in the data jack are reduced considerably, with the result that the risk of damage to the contact springs 11 to 18 is reduced.

[0027] The second, elastically deformable section 20 of the contact springs 11 to 18 has two subsections 27 and 28. As can best be seen from Figure 3, these two subsections 27 and 28 are inclined differently with respect to a horizontal H, which runs parallel to an insertion direction E of the data plug 26 into the electrical plug-type connector, the first section 27, which adjoins the respective free end 25 of the respective contact spring, being inclined through an angle β_1 with respect to the horizontal H, and the second section 28 of the respective contact spring, said section adjoining the first section 27,

being inclined through an angle β_2 with respect to the horizontal H.

[0028] In this case, as shown in Figure 3, the angle of inclination β_1 of the first section 27 is greater than the angle of inclination β_2 of the second section 28 with respect to the horizontal H, the two subsections 27 and 28 enclosing an angle $\Delta\beta$ of between 35° and 45° in the load-free state (shown in Figure 3) of the respective contact spring.

[0029] The angle β_1 , through which the first subsection 27 of the second section 20 of the respective contact spring is inclined with respect to the horizontal H or insertion direction E of the data plug 26, is between 62.5° and 67.5° .

[0030] The angle β_2 , on the other hand, through which the second subsection 28 of the second section 20 is inclined with respect to the horizontal H or the insertion direction E, is between 22.5° and 27.5° .

[0031] As can be seen from Figure 4, the second section 28 with the relatively small angle of inclination β_2 with respect to the horizontal H or the insertion direction E is used for making contact between the respective contact spring and the contacts of the data plug 26.

[0032] By virtue of this above configuration of the contact springs, it is possible for the required plugging force during insertion of a data plug into the data jack and therefore likewise the stress in the contact springs to be reduced further, as a result of which the risk of damage to the contact springs when contact is made between a data plug and the data jack can be reduced further.

[0033] Another particular feature of the electrical plug-type connector according to the disclosure consists in that, as can be seen from Figure 5, the contact springs 11 to 18 have a portion of thickened material 29 adjacent to the first section 19, which is used for anchoring the respective contact spring in the printed circuit board 10. By virtue of this portion of thickened material 29, the width of the respective contact spring is increased sectionally in a section 30 which is positioned between the first section 19 and the second section 20 of the respective contact spring. As a result, the strength of the contact spring is increased, so that said contact spring can absorb greater forces. This also reduces the risk of the contact springs being damaged when a data plug is inserted into the data jack.

List of reference symbols

[0034]

10 printed circuit board
 11 contact spring
 12 contact spring
 13 contact spring
 14 contact spring
 15 contact spring
 16 contact spring
 17 contact spring

18 contact spring
 19 first section
 20 second section
 21 contact holder
 22 section
 23 section
 24 cutout
 25 end
 26 data plug
 27 subsection
 28 subsection
 29 portion of thickened material
 30 section

Claims

1. Electrical plug-type connector, namely data jack for receiving, in contact-making fashion, at least one data plug, with a housing and with a connecting device positioned in the housing, the connecting device having a printed circuit board with electrical conductors, the connecting device furthermore having contact springs, via which contact can be made between the conductors of the printed circuit board and contacts of a data plug, the contact springs being anchored, at a first section thereof, in the printed circuit board and permanent contact thus being made between said contact springs and the conductors of said printed circuit board, and it being possible for contact to be made between the contact springs, via a second, elastically deformable section, and the contacts of a data plug, **characterized in that** the second, elastically deformable section (20) of the contact springs (11, 12, 13, 14, 15, 16, 17, 18) has two subsections (27, 28), which are inclined differently with respect to a horizontal or the insertion direction of the data plug, the two subsections (27, 28) enclosing an angle ($\Delta\beta$) of between 35° and 45° in the load-free state of the contact springs (11, 12, 13, 14, 15, 16, 17, 18).
2. Plug-type connector according to Claim 1, **characterized in that** a first subsection (27), which adjoins a free end (25) of the contact springs, encloses an angle (β_1) of between 62.5° and 67.5° with the horizontal (H) or insertion direction (E) of the data plug in the load-free state of the contact springs (11, 12, 13, 14, 15, 16, 17, 18), and **in that** a second subsection (28), which adjoins the first subsection (27), encloses an angle (β_2) of between 22.5° and 27.5° with the horizontal (H) or insertion direction (E) of the data plug in the load-free state of the contact springs (11, 12, 13, 14, 15, 16, 17, 18).
3. Electrical plug-type connector according to Claim 1 or 2, **characterized in that** the contact springs (11, 12, 13, 14, 15, 16, 17, 18) have a portion of thickened material (29) adjacent to the first sections (19) of said

contact springs in a section (30).

- 4. Plug-type connector according to Claim 3, **characterized in that** the portion of thickened material (29) increases the width of the respective contact springs (11, 12, 13, 14, 15, 16, 17, 18). 5

- 5. Electrical plug-type connector according to one of Claims 1 to 4, **characterized in that** at least some contact springs (12, 13, 14, 15, 16, 17) are free of any load when there is no data plug in the data jack. 10

- 6. Plug-type connector according to Claim 5, **characterized in that** free ends (25) of the load-free contact springs, said ends adjoining the second section (20) thereof, do not bear either against a contact holder (21) of the housing or against the printed circuit board (10) but instead are located freely in space when there is no data plug in the data jack. 15
20

- 7. Plug-type connector according to Claim 5 or 6, **characterized in that** when there is no data plug in the data jack, the central or inner contact springs (12, 13, 14, 15, 16, 17), with respect to free ends (25) thereof, are free of any load, whereas the two outer contact springs (11, 18), with respect to free ends (25) thereof, are not free of load. 25

- 8. Plug-type connector according to Claim 7, **characterized in that** the two outer, non-load-free contact springs (11, 18) bear against the contact holder (21) of the housing. 30

- 9. Plug-type connector according to Claim 5 or 6, **characterized in that** when there is no data plug in the data jack, all of the contact springs (11, 12, 13, 14, 15, 16, 17, 18) are free of any load. 35

40

45

50

55

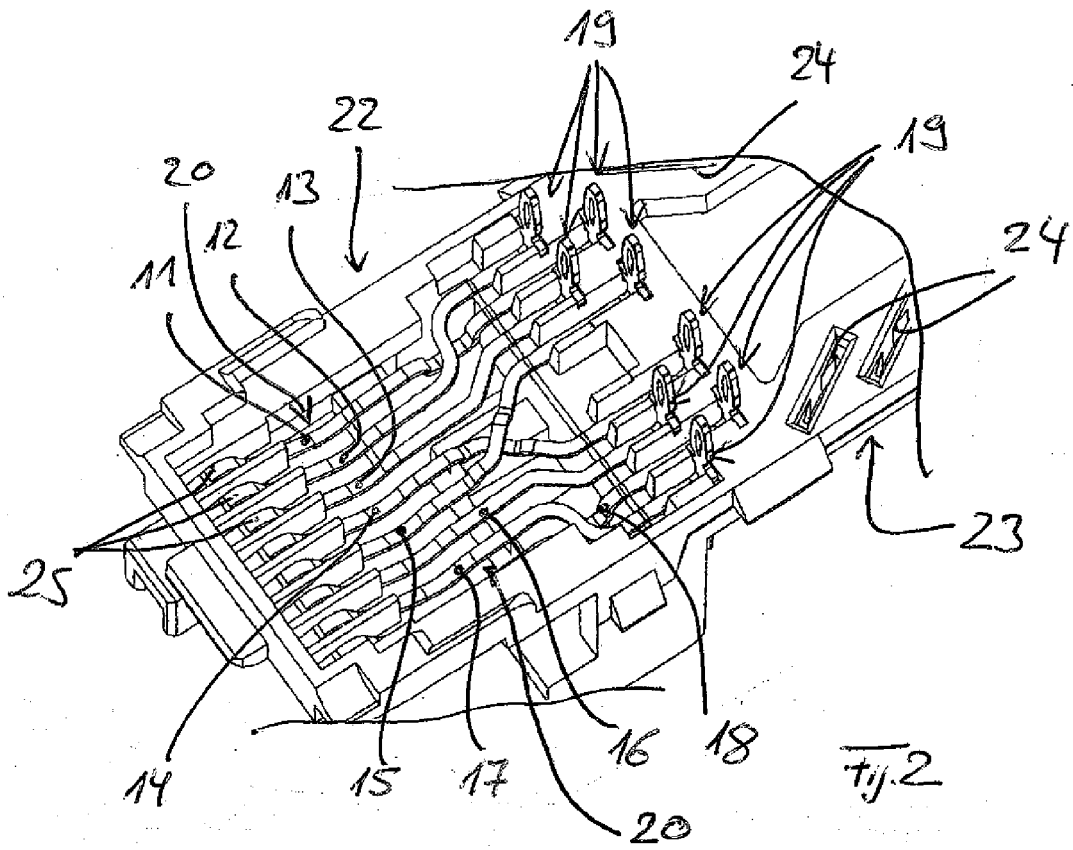
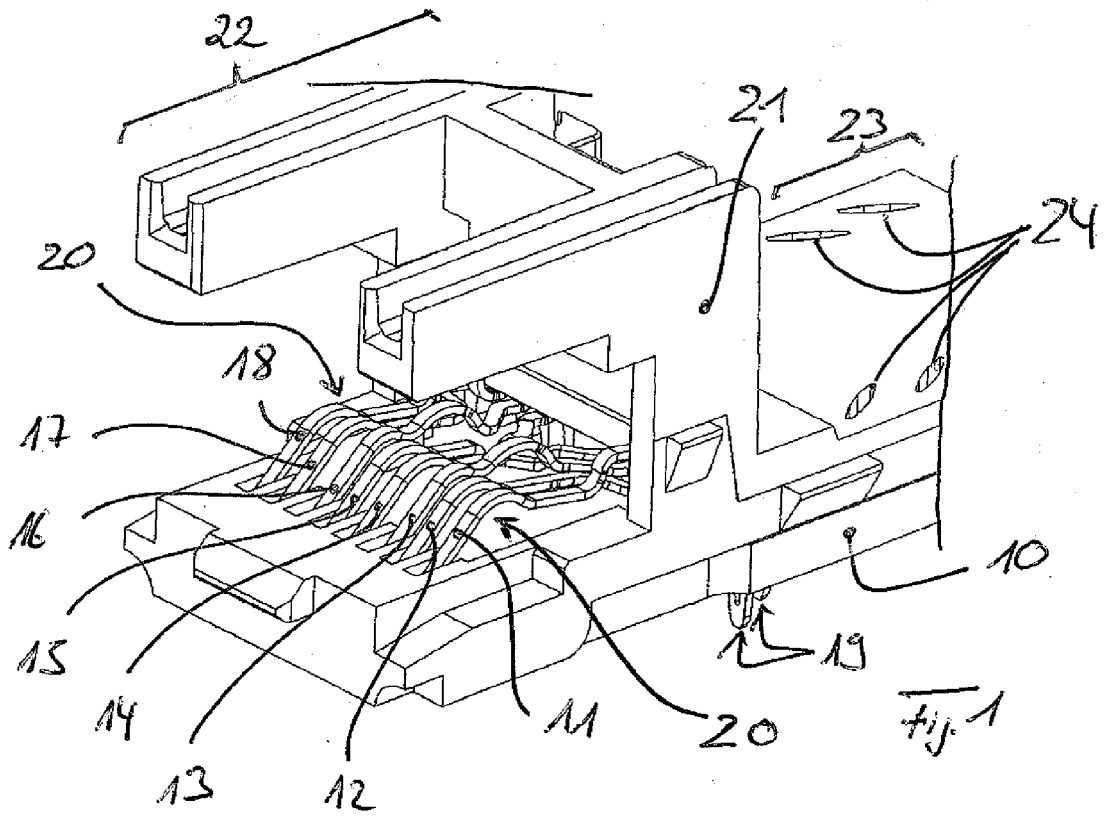

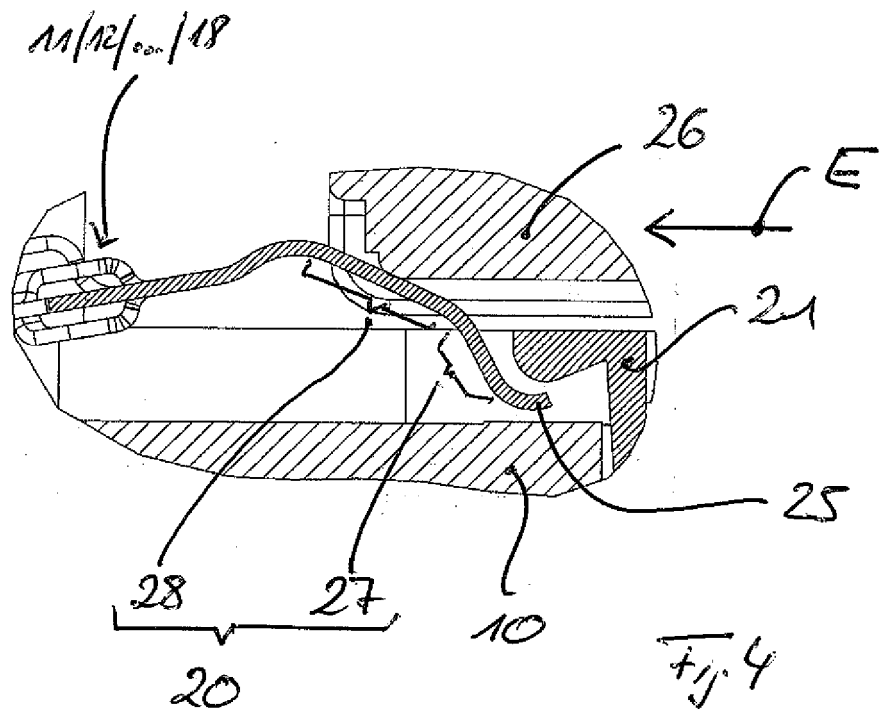
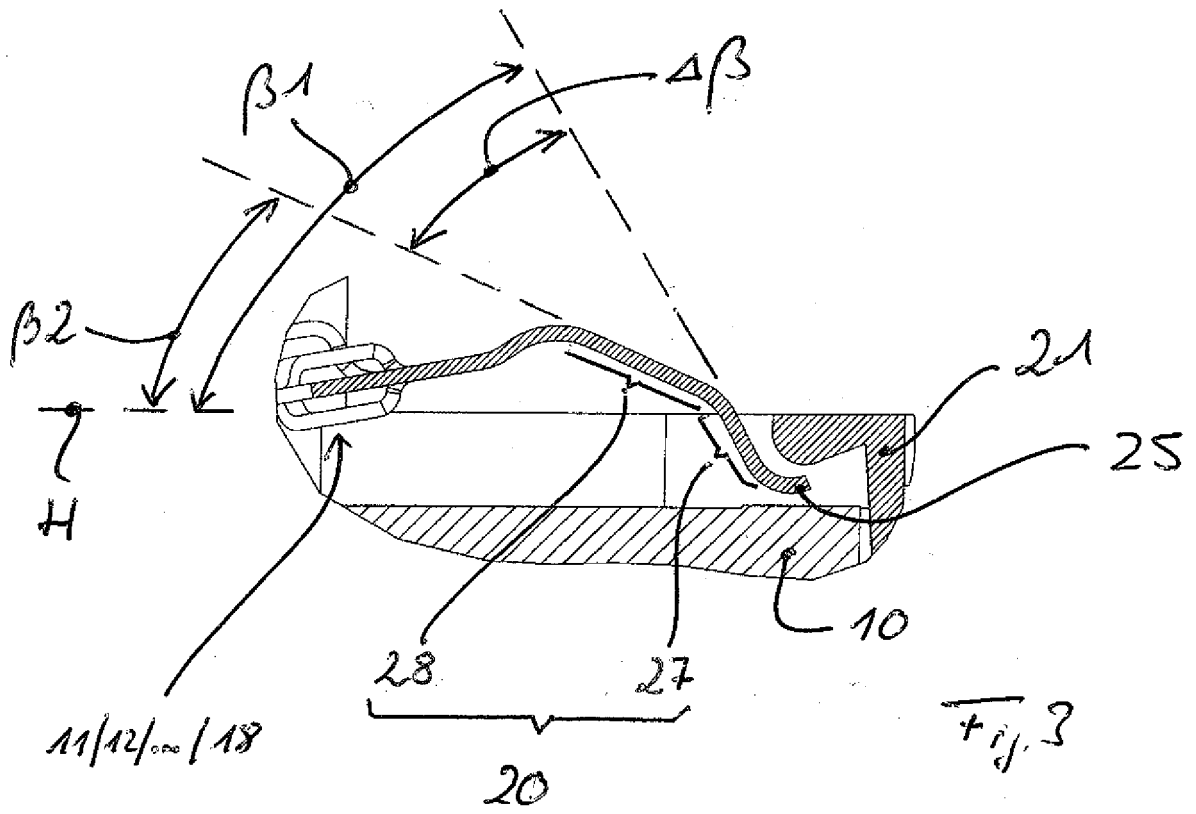

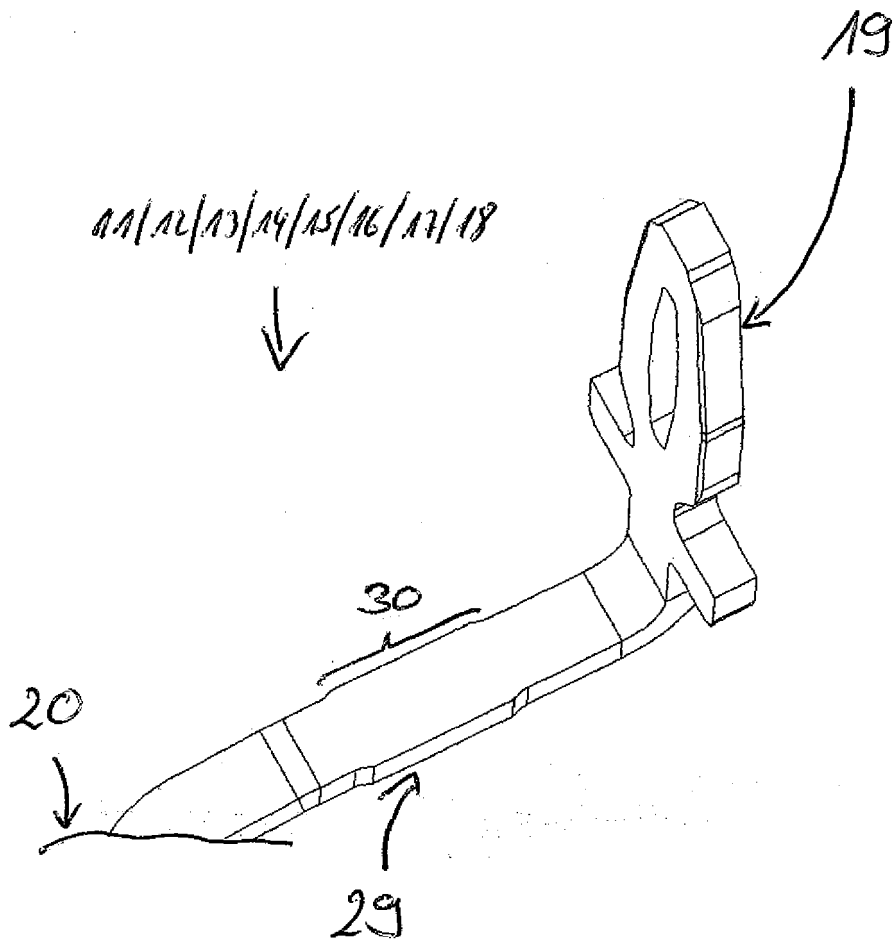

Fig. 5



EUROPEAN SEARCH REPORT

Application Number
EP 17 18 7459

5

10

15

20

25

30

35

40

45

50

55

DOCUMENTS CONSIDERED TO BE RELEVANT			
Category	Citation of document with indication, where appropriate, of relevant passages	Relevant to claim	CLASSIFICATION OF THE APPLICATION (IPC)
X	US 7 427 218 B1 (HASHIM AMID I [US] ET AL) 23 September 2008 (2008-09-23) * column 8 - column 10; figures 3-5 * -----	1,5-9	INV. H01R13/66 H01R24/64 H01R12/55
X	EP 1 022 818 A2 (THOMAS & BETTS INT [US]) 26 July 2000 (2000-07-26) * figure 2 * -----	1,2,5-9	ADD. H01R24/62
X	EP 1 022 820 A2 (THOMAS & BETTS INT [US]) 26 July 2000 (2000-07-26) * columns 5,6; figures 1,2,4 * -----	1,2	
X	US 5 478 261 A (BOGESE II STEPHEN B [US]) 26 December 1995 (1995-12-26) * column 7 - column 10; figures 2,5 * -----	1-4	
The present search report has been drawn up for all claims			TECHNICAL FIELDS SEARCHED (IPC)
			H01R
Place of search		Date of completion of the search	Examiner
The Hague		8 January 2018	Vautrin, Florent
CATEGORY OF CITED DOCUMENTS			
X : particularly relevant if taken alone Y : particularly relevant if combined with another document of the same category A : technological background O : non-written disclosure P : intermediate document		T : theory or principle underlying the invention E : earlier patent document, but published on, or after the filing date D : document cited in the application L : document cited for other reasons & : member of the same patent family, corresponding document	

EPO FORM 1503 03.02 (P04C01)

ANNEX TO THE EUROPEAN SEARCH REPORT
ON EUROPEAN PATENT APPLICATION NO.

EP 17 18 7459

5 This annex lists the patent family members relating to the patent documents cited in the above-mentioned European search report.
The members are as contained in the European Patent Office EDP file on
The European Patent Office is in no way liable for these particulars which are merely given for the purpose of information.

08-01-2018

Patent document cited in search report	Publication date	Patent family member(s)	Publication date
US 7427218	B1	23-09-2008	NONE
EP 1022818	A2	26-07-2000	AT 291784 T 15-04-2005 CA 2291293 A1 25-07-2000 DE 60018824 D1 28-04-2005 DE 60018824 T2 30-03-2006 EP 1022818 A2 26-07-2000 JP 4573385 B2 04-11-2010 JP 2000223196 A 11-08-2000 US 7223128 B1 29-05-2007
EP 1022820	A2	26-07-2000	CA 2291295 A1 25-07-2000 DE 60034082 T2 13-12-2007 EP 1022820 A2 26-07-2000 JP 4489226 B2 23-06-2010 JP 2000223197 A 11-08-2000 US 6093059 A 25-07-2000
US 5478261	A	26-12-1995	NONE

EPO FORM P0459

For more details about this annex : see Official Journal of the European Patent Office, No. 12/82

REFERENCES CITED IN THE DESCRIPTION

This list of references cited by the applicant is for the reader's convenience only. It does not form part of the European patent document. Even though great care has been taken in compiling the references, errors or omissions cannot be excluded and the EPO disclaims all liability in this regard.

Patent documents cited in the description

- DE 202011005469 [0001]
- US 6530810 B2 [0003] [0004]