



(11) **EP 3 284 687 A1**

(12) **EUROPEAN PATENT APPLICATION**

(43) Date of publication:
21.02.2018 Bulletin 2018/08

(51) Int Cl.:
B65D 5/355 (2006.01) **B65B 57/10 (2006.01)**
B65B 61/00 (2006.01) **B65B 5/02 (2006.01)**
B65D 5/28 (2006.01)

(21) Application number: **16190898.3**

(22) Date of filing: **27.09.2016**

(84) Designated Contracting States:
AL AT BE BG CH CY CZ DE DK EE ES FI FR GB GR HR HU IE IS IT LI LT LU LV MC MK MT NL NO PL PT RO RS SE SI SK SM TR
Designated Extension States:
BA ME
Designated Validation States:
MA MD

(71) Applicant: **Neopost Technologies**
92220 Bagneux (FR)

(72) Inventors:
• **Sytema, Herman**
9201 BX Drachten (NL)
• **de Boer, Fokke**
9201 BX Drachten (NL)

(30) Priority: **16.08.2016 DE 102016115213**

(74) Representative: **CBDL Patentanwälte**
Königstraße 57
47051 Duisburg (DE)

(54) **SYSTEM AND METHOD FOR AUTOMATICALLY PACKAGING ITEMS VARYING IN SIZE AND NUMBER FOR SHIPMENT**

(57) A system for automatically packaging items that vary in size and number for shipment, comprising a packaging station for holding a pre-folded cardboard box (10) to receive one or more items (26, 28, 30, 32) to be packaged, said pre-folded cardboard box (10) having a bottom panel (12), two side panels (14, 16) and a first end panel, the first end panel being joined to each of said side panels (14, 16), the side panels (14, 16) and the end panel being erected from the bottom panel (12) to form a box having

an open top and an open side, the bottom panel (12) having an end portion intended to form a second end panel, each side panel having an end portion intended to form a corner panel, at least one cutting unit for adjustably shortening the end portions of the side panels (14, 16) and the end portion of the bottom panel (12) and at least one folding unit for folding the corner panels and the second end panel to close said open side of the box.

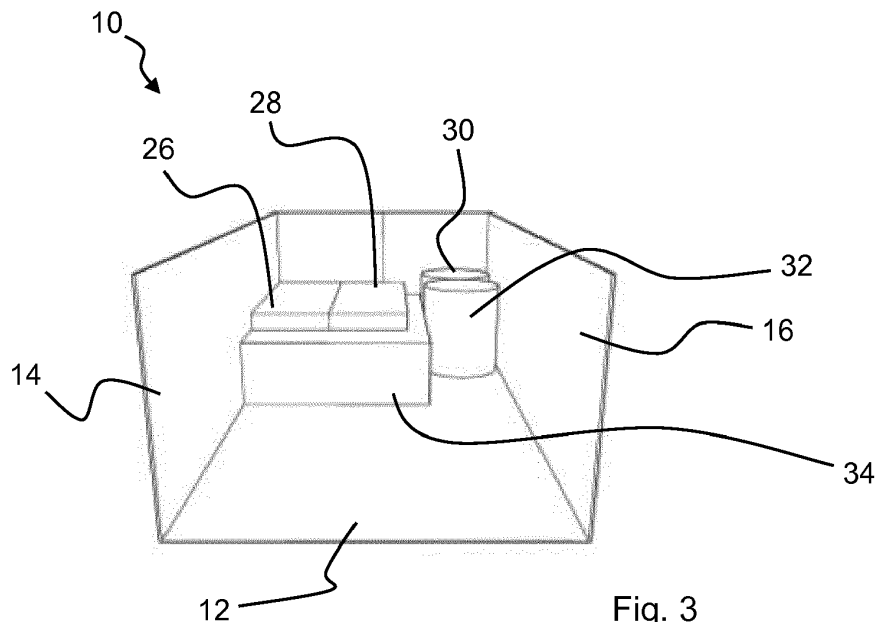

EP 3 284 687 A1

Description

TECHNICAL FIELD OF THE INVENTION

[0001] The invention relates to a system and a method for automatically packaging items that vary in size and number for shipment.

BACKGROUND OF THE INVENTION

[0002] Mail ordering has become a widely used way of buying goods. More and more companies offer virtual department stores, in which the customers can electronically put goods in a shopping cart that later will be transferred by the respective company into a dispatch order, so that in a warehouse a shipment comprising the items ordered (and sometimes additional items such as samples, vouchers, invoices, etc.) can be assembled based on the respective dispatch order.

[0003] While assembling a shipment in a warehouse is nowadays often done more or less fully automated, packaging the items to be shipped is still a challenge, in particular when a shipment comprises several items of different sizes and in different quantities. Often, the items to be packaged are provided automatically to a person packaging the items manually. Depending on the size and number of the items, the person selects a suitable box size. Generally the box is a cardboard box that upon packaging is assembled from a corresponding cardboard blank.

[0004] To automate the packaging process even in cases where the items vary in size and number, a system has been proposed in WO 2014/117817 A1 that allows creating a fully custom sized box, i.e. a box, of which width, length and height are adapted to the respective content of the box. The box is created from a roll or a stack of cardboard by cutting out and creasing a custom sized blank from which then the box is folded automatically.

[0005] WO 2016/059218 A1 discloses a system and a method for automatically packaging items varying in size and number applying two separate packings, namely an inner packing surrounding the items to be packaged in a first direction, and an outer packing surrounding the inner packing in a second direction, said second direction being substantially perpendicular to the first direction such that the inner and the outer packing form a combined package enclosing the package items from all sides.

[0006] WO 2013/117852 A1 discloses a system and a method for reducing the height of a cardboard box to the apex of the highest item in the box. In this respect, it should be noted that the terms "height", "length" and "width" as used herein refer to the usual definitions of the three dimensions of a box having the shape of a rectangular block with a rectangular bottom and two pairs of parallel rectangular sidewalls, wherein

- the height of the box is defined by the length of the

sidewalls in the direction from the bottom to the top of the box,

- the width of the box is defined by the length of the bottom between the first pair of parallel sidewalls, usually the pair of sidewalls forming for an observer the left and the right sidewalls of the box, and
- the length (sometimes also called depth) of the box is defined by the length of the bottom between the second pair of parallel sidewalls, usually the pair of sidewalls forming for an observer the front and the back of the box.

[0007] It is hence obvious that depending on the position of the observer, the terms length and width can be interchanged. For sake of simplicity, in the following it is assumed that the box is seen from one perspective and length and width hence have a distinct meaning, which however is not limiting and obviously what in is the following is called width can be named length (or depth) and vice versa.

DISCLOSURE OF THE INVENTION

[0008] While the known systems and methods work well for a number of applications, it has turned out that there is a need for optimization of the packaging process under a number of aspects. Depending in particular on the number and the shape of the items to be packaged, creating a custom sized box around items to be packaged can be difficult. If pre-fold boxes are used as disclosed in WO 2013/117852 A1, of which the height can be changed, the finished package may not be optimal with respect to volume, while transportation costs often do not only depend on the weight, but also on the volume of a package. Besides, placing the items in a pre-folded box having the usual rectangular block shape with a bottom and four sidewalls and being open only towards the top, usually requires gripping and lifting the items over one of the sidewalls, which in particular in cases, in which a huge variety of items of different shapes and sizes needs to be packaged, can be difficult to automate.

[0009] It is an object of the invention to disclose a system and a method allowing customizing at least the length of a box. It is also an object of the invention to disclose a system and a method that employ a pre-folded and hence stable box being open not only towards the top, but also towards one of the sides, which pre-folded box may also be used for assembling a number of items, which shall be shipped together in a single package.

[0010] The object is achieved by a system according to claim 1 respectively a method according to claim 9. The respective dependent claims refer to advantageous embodiments of the respective independent claims.

[0011] The invention is based on the idea that by placing the items to be shipped on a cardboard box having a bottom panel, two side panels and a first end panel, the first end panel being joined to each of said side panels, the side panels and the end panel being erected from

the bottom panel to form a box having an open top and an open side, a huge variety of items differing in number and shape can be packaged using the same pre-folded box, which is then adapted in at least one dimension, namely length. This idea as well as advantages and different variations of the invention will become apparent from the following description of preferred embodiments in conjunction with the drawings.

BRIEF DESCRIPTION OF DRAWINGS

[0012]

- Fig. 1 shows a pre-folded cardboard box according to the invention.
- Fig. 2 shows a blank for forming the box according to Fig. 1
- Fig. 3 shows the pre-folded box according to Fig. 1, in which some items to be packaged in the box are arranged
- Fig. 4 shows the box according to Fig. 3 after the end portions of the side panels and the bottom panel have been shortened.
- Fig. 5 shows the box according to Fig. 4 after crease lines have been introduced in the side panels and the bottom panel to define second corner panels and a second end panel.
- Fig. 6 shows the box according to Fig. 5 after the second corner panels have been folded inwards.
- Fig. 7 shows the box according to Fig. 6 after the second end panel has been folded upwards.
- Fig. 8 shows the box according to Fig. 7 after the height of the box has been shortened to the filling level of the box.
- Fig. 9 shows the box according to Fig. 8 after lid has been placed on top of the box.
- Fig. 10 shows a box according to Fig. 4 and a thin plate used for facilitating folding the end portions of the side panels and the end portion of the bottom panel.

DESCRIPTION OF PREFERRED EMBODIMENTS

[0013] Fig. 1 shows a pre-folded box 10 that is open towards two sides, namely in this view towards the top and towards the front, while the box is closed towards four sides, namely towards the bottom, towards the back and towards the left and the right.

[0014] The bottom is formed by a bottom panel 12, the left and right sides are formed by two side panels 14 and 16, and the back side is formed by two first corner panels 18 and 20 and a first so-called end panel, which in this view is covered by the first corner panels 18 and 20.

[0015] Fig. 2 shows a cardboard blank 22 for forming a box according to Fig. 1. In Fig. 2, the first end panel 24 can be seen. It should be noted that the terms "side panels", "end panels" etc. are just used to easily distinguish the different panels and that apparently in the completely folded state (as shown e.g. in Fig. 7) the panels form a box that has a bottom and four side walls.

[0016] Fig. 3 shows a different perspective of the pre-folded box 10 according to Fig. 1 in a situation, in which some items 26, 28, 30, 32 and 34 have been placed in the box. In order to optimize the box with respect to volume, the pre-folded box is then adapted to the dimensions of the arrangement of items in the box by shortening the panels forming the box as will now be described.

[0017] Fig. 4 shows the situation, in which the bottom panel 12 and the side panels 14 and 16 of the box 10 have been shortened by cutting. The amount of shortening is adapted to the space needed by the items placed in the pre-folded box and in some cases the panels may not be shortened at all.

[0018] Fig. 5 shows the box 10 according to Fig. 4, in which crease lines 36, 38 and 40 have been introduced into the side panels 14 and 16 respectively the bottom panel 12, such that the end portions of the side panels 14 and 16 now define second corner panels 42 and 44, and the end portion of the bottom panel 12 defines a second end panel 46. Cuts 48 and 50 have been introduced along the borderlines between the second corner panels 42 and 44 and the second end panel 46 in order to allow folding. This cutting can be done by the same cutting unit which also shortened the side panels 14 and 16 and the bottom panel 12 or by a separate unit. The cutting as well as the shortening can obviously be done prior to, parallel to or after introducing the crease line 36, 38 and 40.

[0019] Fig. 6 shows the box 10 according to Fig. 5 in a situation, in which the second corner panels 42 and 44 have been folded inwards around the crease lines (36 and 38 in Fig. 5) to close the open side of the box. Prior to folding or after folding, glue can be applied to the second end panel 46 on the side facing the second corner panels 42 and 44 and/or on to the second corner panels 42 and 44 on the side facing the second end panel 46.

[0020] Fig. 7 shows the box 10 according to Fig. 6 in a situation, when the second end panel 46 has been folded around the respective crease line (40 in Fig. 5) against the second corner panels 42 and 44. The box may then be closed by a lid. However, according to a preferred embodiment of the invention, a cutting unit is provided that allows also shortening the height of the box. Such cutting unit may be the same cutting unit that is used for shortening the bottom panel 12 and the side panels 14 and 16 as described above, or may be separate cutting

means.

[0021] Fig. 8 shows the box 10 according to Fig. 7, in which the height of the box has been shortened either to match or to be slightly greater than the maximum height of the arrangement of items in the box, which in this example is defined by the cylindrical items 30 and 32. The height of the box is defined by the length of the respective erected panels in the direction from the bottom panel to the open top of the box. Accordingly, width of the box is defined by the length of the bottom panel in the direction from one side panel 14 to the other side panel 16, and length of the box is defined by the length of the bottom panel in the direction from one end panel 22 to the other end panel 46.

[0022] For shortening the respective panels 14, 16, 18, 20 and 46 as well as the second corner panels and the first end panel, which in the view of Fig. 8 have no separate reference numbers, the same or a different cutting unit, e.g. a laser cutting unit, can be used that is used for shortening the end panel 12 and the side panels 14 and 16 as described in conjunction with Fig. 4 respectively for introducing the cuts 48 and 50. It is obvious that the shortening of the panels defining the height of the box can be done prior to, parallel to or after shortening the second corner panels and the bottom panel as described in conjunction with Fig. 4.

[0023] Fig. 9 shows the box 10 according to Fig. 8 after a lid 52 has been placed on the open top of the box in order to close the box. In this embodiment, the lid 52 has four flaps, of which only two, namely flaps 54 and 56, are visible in Fig. 9. The flaps may be glued to the respective panels of the box, i.e. the flap 54 may be glued to the second end panel 46 respectively the flap 56 may be glued to the side panel 16.

[0024] Fig. 10 shows a box according to Fig. 4 and a thin plate 58 that is used instead of or additionally to the crease lines shown in Fig. 5 for facilitating folding the end portions of the side panels 14 and 16 into second corner panels 42 and 44, and the end portion of the bottom panel 12 into a second end panel 46, once cuts have been introduced along the borderlines between the second corner panels 42, 44 and the second end panel 46 in order to allow folding.

[0025] Plate 58 has approximately the width of the open front of the box 10 formed between the side panels 14 and 16 and the bottom panel 12 and is placed in the box against the items in the box. In this embodiment, plate 58 has a width slightly less than the width of the pre-folded box 10. The second corner panels 42, 44 and the second end panel 46 can then be formed by folding the respective end portions of the side panels 14 and 16 respectively the end portion of the bottom panel 12 around the respective edges 60, 62, 64 of the plate 58. Hence, plate 58 functions as a fold blade. When using such plate, it may, depending in particular on the characteristics of the cardboard used, not be necessary to indent crease lines. Plate 58 also facilitates keeping the items in the box 10 and can also support the second

corner panels 42 and 44 from inside the box in case they are glued to the second end panel 46, which would then be pressed against them from outside the box. Typically, the plate 58 will be a thin and stiff metal plate.

[0026] In this embodiment, plate 58 comprises two handles 66 for positioning it automatically or manually. Preferably, plate 58 is positioned in the box by moving it along a path that ensures that items in the box are not jammed between the plate and e.g. the bottom panel, e.g. by inserting the plate from the open side such that its main surfaces run substantially parallel to the first end panel and moving it towards the first end panel. Depending on the installation situation, the plate may follow different insertion paths. The plate can be retracted once the corner panels 42, 44 and, optionally, also the second end panel 46 have been folded.

[0027] Within the scope of protection of the invention, which is only defined by the appended claims, numerous variations and embodiments are possible. For example, whereas in the shown embodiments the first corner panels and the second corner panels each have a length corresponding to the half of the width of the bottom panel 12, such that the free ends of the respective corner panels abut against each other, it is obvious that the corner panels may overlap or may form a gap between them.

[0028] It is obvious for an expert that the crease lines shown in Fig. 5 are arranged such that the thickness of the cardboard, in particular corrugated cardboard, which is used for the box, is taken into account, so that the crease lines defining the second corner panels are in a slightly different plane than the crease line defining the second end panel in order to allow that all three panels may form a right angle with the respective panel, from which they are folded.

[0029] It is also obvious for an expert that, while in the shown embodiments the corner panels in the finished box lie in the inside of the box and the first and second end panels form part of the outside of the box, it is as well possible that the order is reversed and the end panels are inside the box and the corner panels are outside the box.

[0030] While in a preferred embodiment the corner panels and the end panels are glued together, it is as well possible to use other means for fixing and stabilising the box, i.e. attaching the respective panels to each other by means of self-adhesive tape or the like.

[0031] It is also possible to introduce crease lines between the side panels and the end panel as well as additional 45° crease lines in either the corner panels 42 and 44 or the end panel 46, originating from the intersection of the bottom panel 12, the end panel 46 and the respective corner panels 42 and 44, such that the corner panels can be folded inwardly without introducing cuts.

[0032] The invention has the great advantage that blanks of a standard shape respectively standard pre-formed boxes can be used to form a huge variety of different sized boxes such that advantageously not a lot of different boxes have to be kept in stock at a packaging

company.

[0033] The invention advantageously allows adjusting at least the length (or, depending on the view, the width) of a box in order to fit optimal to the arrangement of items to be packaged in the box. In a preferred embodiment, also the height of the box can be adjusted.

[0034] Depending on the volume of boxes needed, it may be advantageous for customers to apply an optional box forming unit that may produce pre-folded boxes on-site. Such box forming unit may even be adapted to form custom sized pre-folded boxes from cardboard blanks or from cardboard continuously fed to the box forming unit from a stack of zig-zag-folded corrugated cardboard, such that all dimensions of the boxes can be varied as needed.

[0035] The items in the box may be arranged manually or automatically in the box. The dimensions of the arrangement may be measured e.g. by a laser measuring unit or may be calculated from data known about the arrangement and/or the single items in the arrangement. It may be foreseen that a central control unit calculates an optimal arrangement of the items to be packaged and either controls a placing unit for automatically arranging the items or displays the optimal arrangement via a screen to a person manually arranging the items in the box.

[0036] In order to ensure proper support of the items upon closing the open side of the box by folding the respective panels, the cardboard box may be held such that the bottom panel is slightly inclined downwards from the open end towards the first end panel, ensuring that gravity forces the arrangement against the end panel and at least one of the respective side panels.

[0037] The respective pre-fold box may even be used for assembling the items to be shipped, i.e. the box can be placed on a trolley used by an order picker to pick up the items of an order from a storage. Obviously, the trolley could advantageously also be adapted to hold the pre-folded box slightly inclined such that items placed in the box cannot fall out of the open end of the box.

Claims

1. A system for automatically packaging items that vary in size and number for shipment, comprising
 - a packaging station for holding a pre-folded cardboard box to receive one or more item(s) to be packaged, said pre-folded cardboard box having a bottom panel, two side panels and a first end panel, the first end panel being joined to each of said side panels, the side panels and the end panel being erected from the bottom panel to form a box having an open top and an open side, the bottom panel having an end portion intended to form a second end panel, each side panel having an end portion intended to

form a corner panel,

- at least one cutting unit for adjustably shortening the end portions of the side panels and the end portion of the bottom panel,
- at least one folding unit for folding the corner panels and the second end panel to close said open side of the box.

2. The system according to claim 1, **characterized in that** at least one cutting unit is adapted to introduce cuts between the end portions of the side panels intended to form said corner panels and the end portion of the bottom panel intended to form said second end panel.
3. The system according to one of claims 1 or 2, **characterized by** comprising a box forming unit for producing pre-folded boxes each having a bottom panel, two side panels and a first end panel, the first end panel being joined to each of said side panels, the side panels and the end panel being erected from the bottom panel to form a box having an open top and an open side from cardboard blanks.
4. The system according to one of claims 1 to 3, **characterized by** comprising a lid placing unit for placing a lid on top of the fully folded box.
5. The system according to one of claims 1 to 4, **characterized in that** said packaging station is adapted for holding the pre-folded cardboard box such that the bottom panel is slightly inclined downwards from the open end towards the first end panel.
6. The system according to one of claims 1 to 5, **characterized by** comprising a central control unit calculating a possible arrangement of the item(s) to be packaged that is optimized under predetermined criteria such as volume and/or stability of the finally folded box.
7. The system according to one of claims 1 to 6, **characterized by** comprising a cutting unit for adjustably shortening the panels defining the height of the box.
8. The system according to one of claims 1 to 7, **characterized by** comprising at least one creasing unit for introducing a crease line in the bottom panel to define the second end panel and/or for introducing a crease line in each side panel to define the respective corner panel.
9. A method for automatically packaging items that vary in size and number for shipment, comprising the following steps:
 - arranging one or more more item(s) to be packaged in a pre-folded cardboard box, said pre-

- folded cardboard box having a bottom panel, two side panels and a first end panel, the first end panel being joined to each of said side panels, the side panels and the end panel being erected from the bottom panel to form a box having an open top and an open side, the bottom panel having an end portion intended to form a second end panel, each side panel having an end portion intended to form a corner panel,
- depending on the dimensions of the arrangement of the one or more item(s), shortening as needed the end portions of the side panels and the end portion of the bottom panel,
 - folding the second corner panels and the second end panel to close said open side of the box.
- 10.** The method according to claim 9, **characterized by** comprising a step of applying glue to the second end panel and/or to the corner panels prior to folding it/them.
- 11.** The method according to claim 9 or 10, **characterized by** comprising a step of introducing cuts between the end portions of the side panels intended to form said corner panels and the end portion of the bottom panel intended to form said second end panel.
- 12.** The method according to one of claims 9 to 11, **characterized by** comprising a step of determining the height and/or the length of an arrangement of items placed on the bottom panel prior to shortening the panels.
- 13.** The method according to one of claims 9 to 12, **characterized by** comprising a step of shortening the panels defining the height of the box.
- 14.** The method according to one of claims 9 to 13, **characterized by** comprising a step of introducing a crease line in the bottom panel to define the second end panel and/or of introducing a crease line in each side panel to define the respective corner panel.
- 15.** The method according to one of claims 9 to 14, **characterized by** comprising a step of placing a plate inside the box at the open side against the item(s) placed within the box.

50

55

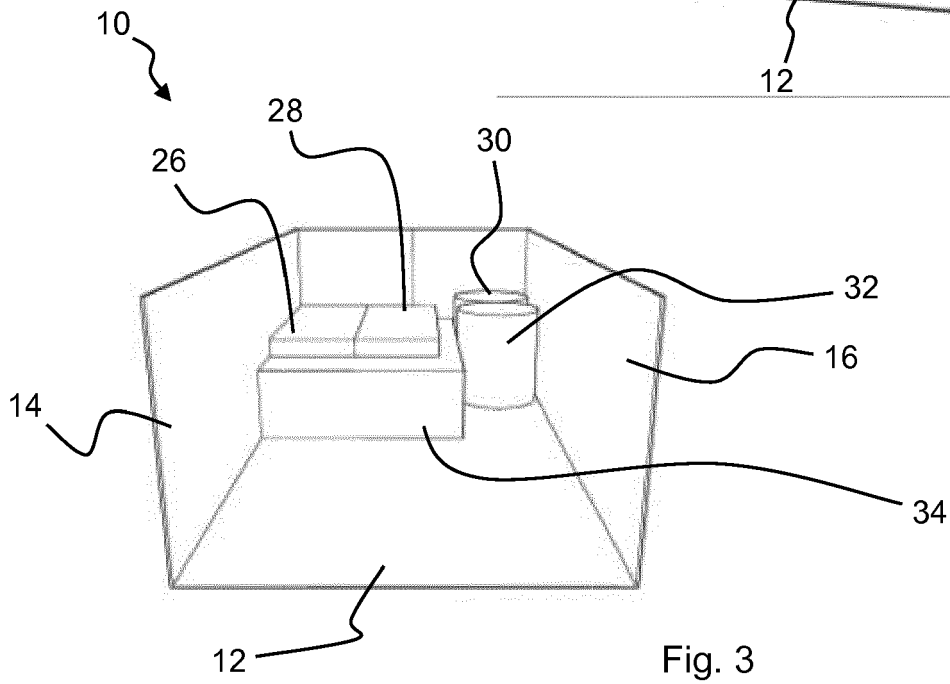
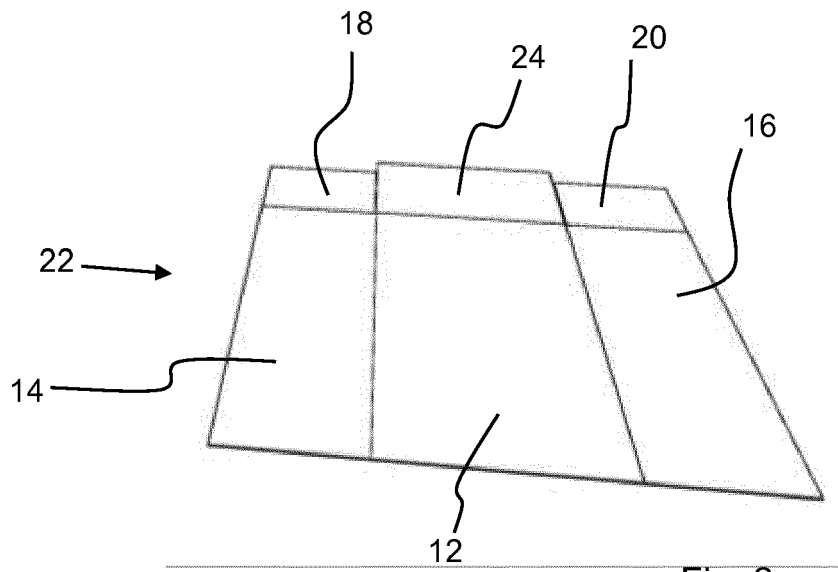
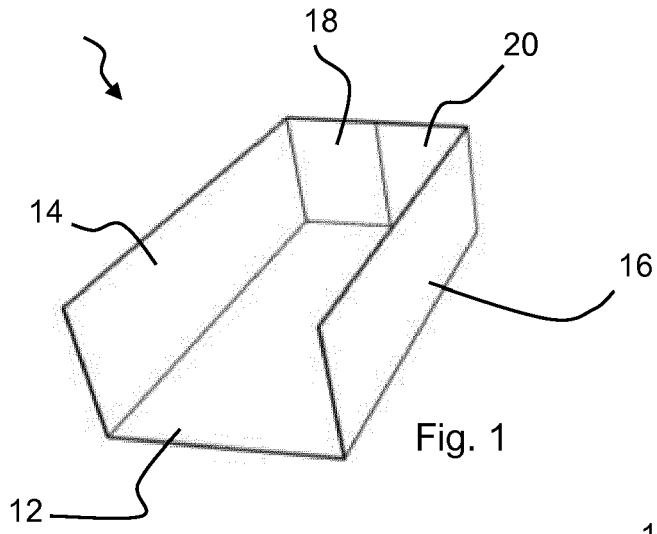

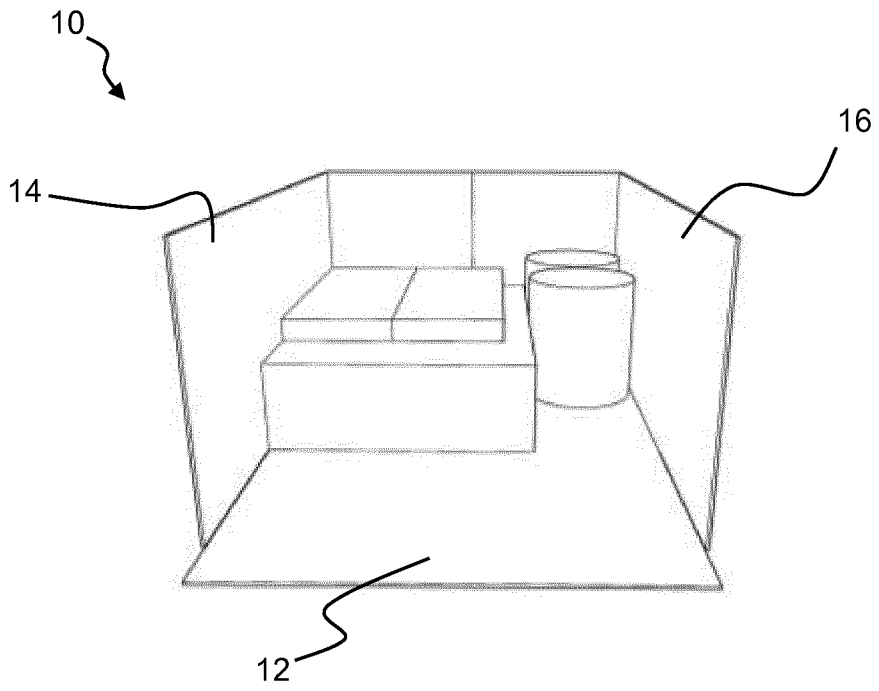

Fig. 4

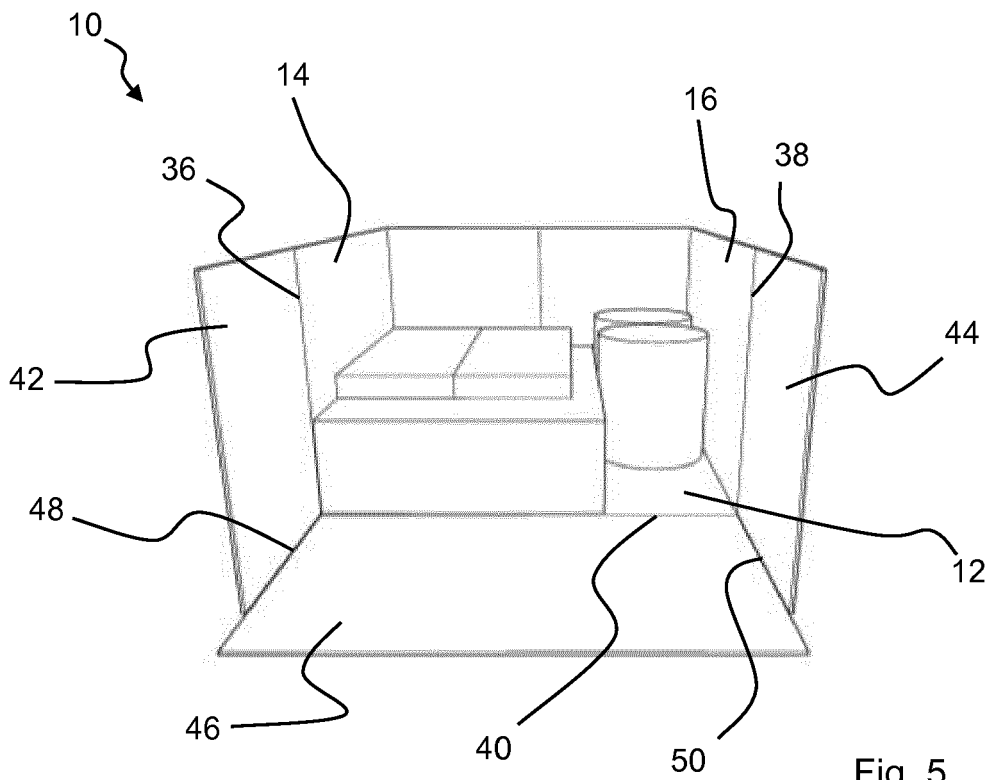

Fig. 5

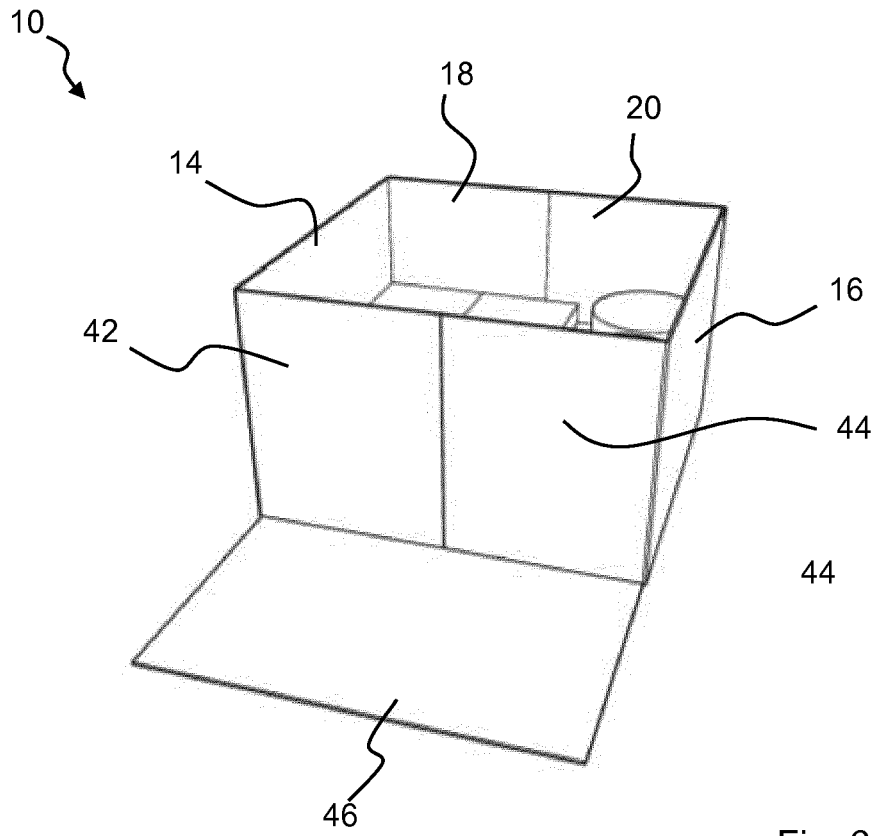

Fig. 6

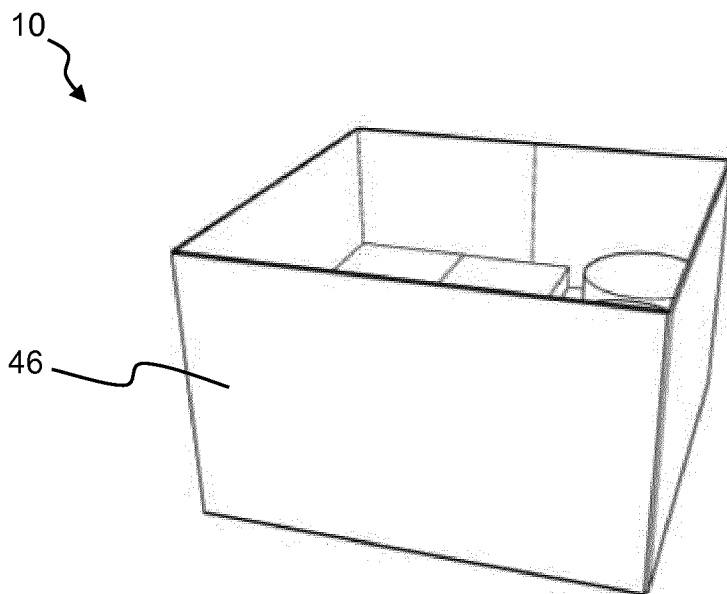

Fig. 7

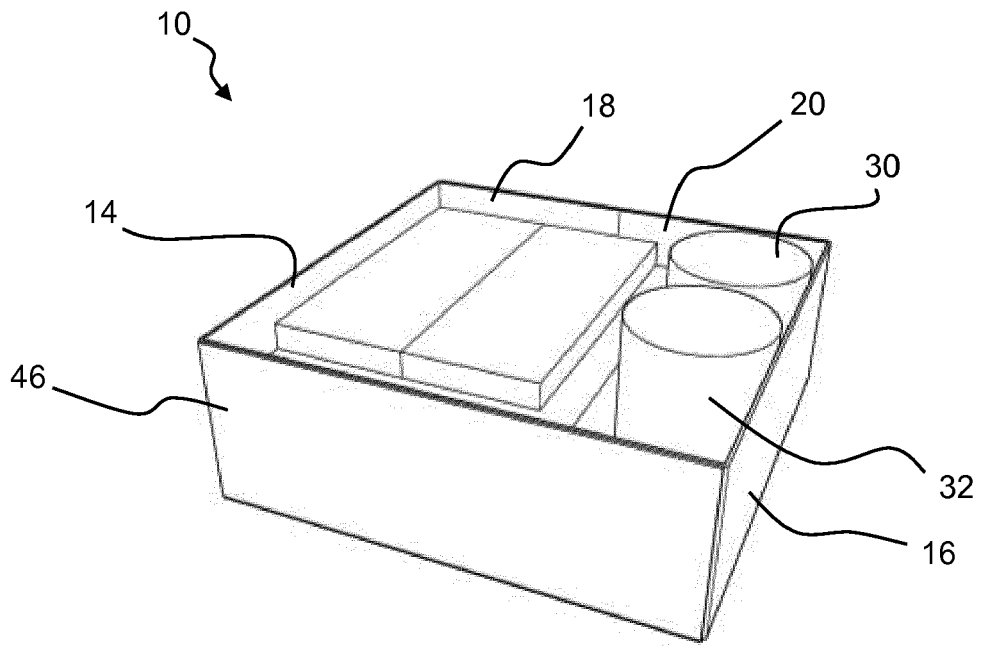

Fig. 8

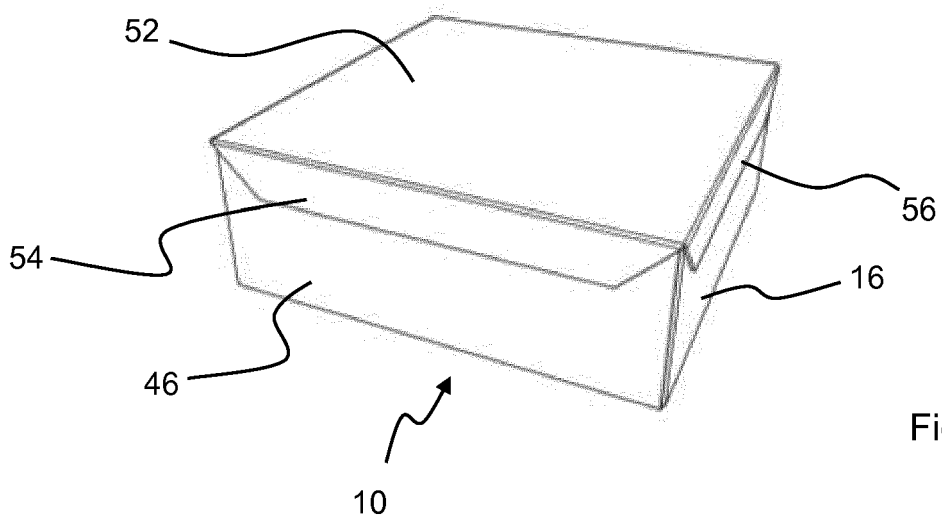

Fig. 9

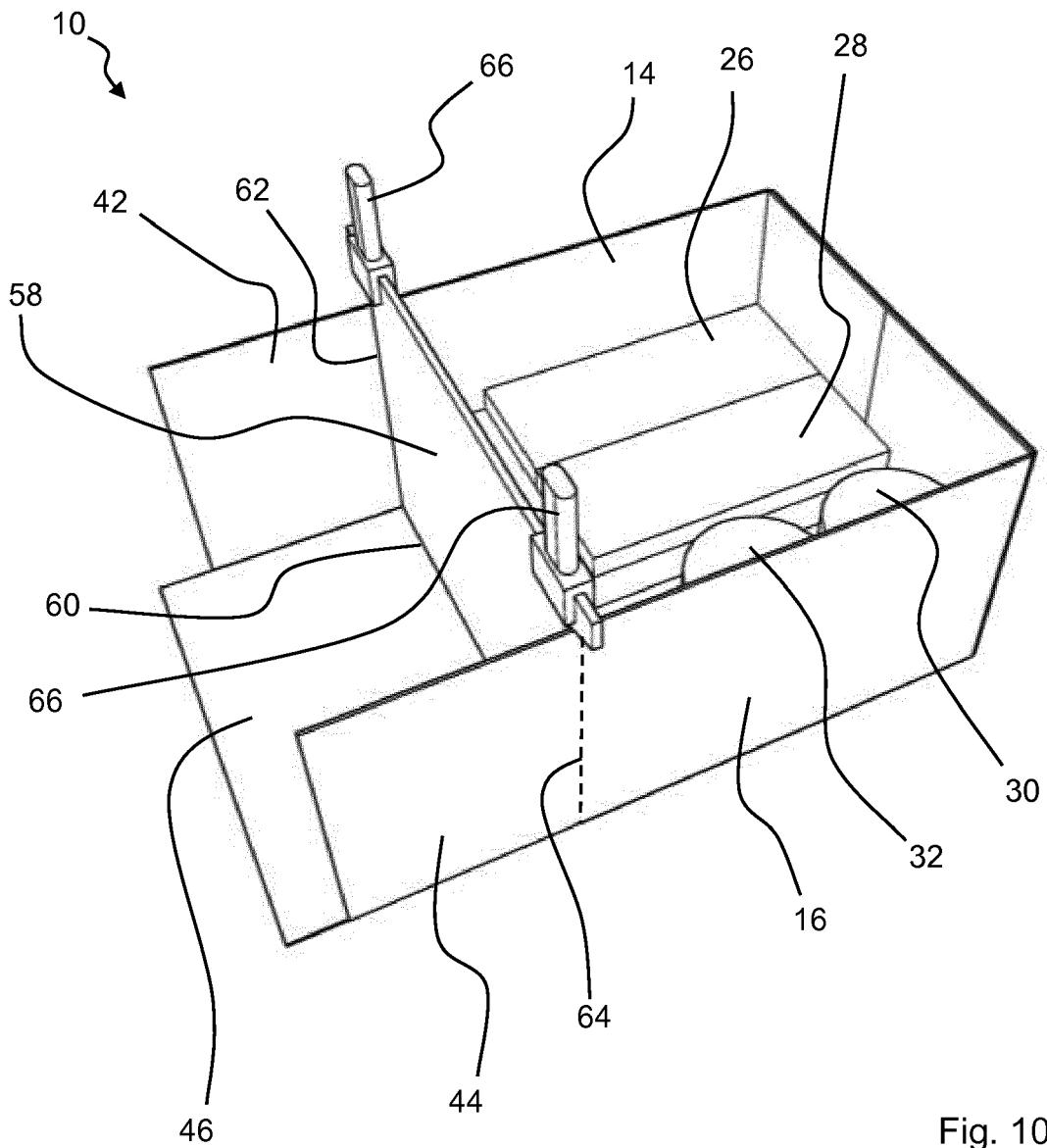

Fig. 10



EUROPEAN SEARCH REPORT

Application Number
EP 16 19 0898

5

10

15

20

25

30

35

40

45

50

55

DOCUMENTS CONSIDERED TO BE RELEVANT			
Category	Citation of document with indication, where appropriate, of relevant passages	Relevant to claim	CLASSIFICATION OF THE APPLICATION (IPC)
Y	WO 96/20869 A1 (JOPAMAC AB OY [FI]; SUOKAS JOUNI [FI]) 11 July 1996 (1996-07-11) * page 6, lines 30-32; figure 1 * * page 9, lines 25-26 * -----	1-15	INV. B65D5/355 B65B57/10 B65B61/00 B65B5/02 B65D5/28
Y	FR 2 987 824 A1 (MARTORELLA GERARD GUY [FR]) 13 September 2013 (2013-09-13) * abstract; figures 1,6 * -----	1-15	
Y	US 2016/185475 A1 (PETTERSSON NIKLAS [SE]) 30 June 2016 (2016-06-30) * the whole document * -----	1-15	
Y	US 2015/360433 A1 (FEIJEN FRANSISCUS HERMANNUS [NL] ET AL) 17 December 2015 (2015-12-17) * the whole document * -----	1-15	
Y	WO 2013/071073 A1 (PACKSIZE LLC [US]; PETTERSSON NIKLAS [US]; OSTERHOUT RYAN [US]) 16 May 2013 (2013-05-16) * the whole document * -----	1-15	TECHNICAL FIELDS SEARCHED (IPC)
Y	US 2014/054361 A1 (DERBY STEPHEN [US] ET AL) 27 February 2014 (2014-02-27) * paragraph [0040]; figure 6 * -----	5	B65D B31B B65B
Y	GB 2 503 677 A (DS SMITH PACKAGING LTD [GB]) 8 January 2014 (2014-01-08) * page 24, lines 19-30; figures 72-79 * -----	15	
The present search report has been drawn up for all claims			
Place of search Munich		Date of completion of the search 26 July 2017	Examiner Garlati, Timea
CATEGORY OF CITED DOCUMENTS X : particularly relevant if taken alone Y : particularly relevant if combined with another document of the same category A : technological background O : non-written disclosure P : intermediate document		T : theory or principle underlying the invention E : earlier patent document, but published on, or after the filing date D : document cited in the application L : document cited for other reasons & : member of the same patent family, corresponding document	

EPO FORM 1503 03.82 (P04C01)

ANNEX TO THE EUROPEAN SEARCH REPORT
ON EUROPEAN PATENT APPLICATION NO.

EP 16 19 0898

5 This annex lists the patent family members relating to the patent documents cited in the above-mentioned European search report.
The members are as contained in the European Patent Office EDP file on
The European Patent Office is in no way liable for these particulars which are merely given for the purpose of information.

26-07-2017

Patent document cited in search report	Publication date	Patent family member(s)	Publication date	
WO 9620869	A1	11-07-1996	AT 184847 T	15-10-1999
			AU 4349096 A	24-07-1996
			CA 2209461 A1	11-07-1996
			CN 1177324 A	25-03-1998
			DE 69604380 D1	28-10-1999
			DE 69604380 T2	11-05-2000
			EP 0800475 A1	15-10-1997
			ES 2140056 T3	16-02-2000
			FI 950040 A	05-07-1996
			JP H10511627 A	10-11-1998
			US 6058684 A	09-05-2000
			WO 9620869 A1	11-07-1996
			FR 2987824	A1
US 2016185475	A1	30-06-2016	US 2016185475 A1	30-06-2016
			WO 2016109337 A1	07-07-2016
US 2015360433	A1	17-12-2015	EP 2951010 A1	09-12-2015
			US 2015360433 A1	17-12-2015
			WO 2014117816 A1	07-08-2014
WO 2013071073	A1	16-05-2013	BR 112014011395 A2	13-06-2017
			BR 112014011396 A2	13-06-2017
			CN 104169073 A	26-11-2014
			CN 104185538 A	03-12-2014
			CN 106003821 A	12-10-2016
			EP 2776221 A1	17-09-2014
			EP 2776239 A1	17-09-2014
			EP 3050684 A1	03-08-2016
			EP 3138672 A1	08-03-2017
			JP 6077556 B2	08-02-2017
			JP 6126614 B2	10-05-2017
			JP 2014534919 A	25-12-2014
			JP 2015502273 A	22-01-2015
			JP 2017061156 A	30-03-2017
			JP 2017077734 A	27-04-2017
			JP 2017081171 A	18-05-2017
			RU 2014123534 A	20-12-2015
			RU 2014123562 A	20-12-2015
			US 2014315701 A1	23-10-2014
			US 2015018189 A1	15-01-2015
WO 2013071073 A1	16-05-2013			
WO 2013071080 A1	16-05-2013			
US 2014054361	A1	27-02-2014	NONE	

EPO FORM P0459

For more details about this annex : see Official Journal of the European Patent Office, No. 12/82

55

**ANNEX TO THE EUROPEAN SEARCH REPORT
ON EUROPEAN PATENT APPLICATION NO.**

EP 16 19 0898

5 This annex lists the patent family members relating to the patent documents cited in the above-mentioned European search report.
The members are as contained in the European Patent Office EDP file on
The European Patent Office is in no way liable for these particulars which are merely given for the purpose of information.

26-07-2017

10

15

20

25

30

35

40

45

50

55

Patent document cited in search report	Publication date	Patent family member(s)	Publication date
GB 2503677	A	08-01-2014	CA 2898395 A1 09-01-2014
			DE 202013012351 U1 22-07-2016
			DE 202013012359 U1 26-07-2016
			EP 2870073 A2 13-05-2015
			GB 2503677 A 08-01-2014
			GB 2503759 A 08-01-2014
			GB 2518519 A 25-03-2015
			GB 2527438 A 23-12-2015
			JP 2015527105 A 17-09-2015
			RU 2015103212 A 20-08-2016
			SG 10201702787P A 30-05-2017
			SG 11201408841T A 29-01-2015
			US 2015166249 A1 18-06-2015
			US 2016296040 A1 13-10-2016
			US 2016297600 A1 13-10-2016
			WO 2014006398 A2 09-01-2014

EPO FORM P0459

For more details about this annex : see Official Journal of the European Patent Office, No. 12/82

REFERENCES CITED IN THE DESCRIPTION

This list of references cited by the applicant is for the reader's convenience only. It does not form part of the European patent document. Even though great care has been taken in compiling the references, errors or omissions cannot be excluded and the EPO disclaims all liability in this regard.

Patent documents cited in the description

- WO 2014117817 A1 [0004]
- WO 2016059218 A1 [0005]
- WO 2013117852 A1 [0006] [0008]