



(12) **EUROPEAN PATENT APPLICATION**

(43) Date of publication:
28.03.2018 Bulletin 2018/13

(51) Int Cl.:
A61G 17/08 (2006.01)

(21) Application number: **17193075.3**

(22) Date of filing: **26.09.2017**

(84) Designated Contracting States:
AL AT BE BG CH CY CZ DE DK EE ES FI FR GB GR HR HU IE IS IT LI LT LU LV MC MK MT NL NO PL PT RO RS SE SI SK SM TR
 Designated Extension States:
BA ME
 Designated Validation States:
MA MD

(71) Applicant: **Laurenskoning B.V.**
6702 EC Wageningen (NL)

(72) Inventor: **LAURENS, Wouter Klaas Jan**
6706 DM Wageningen (NL)

(74) Representative: **Altenburg, Bernardus Stephanus Franciscus**
DOGIO Patents BV
PO Box 2350
1200 CJ Hilversum (NL)

(30) Priority: **26.09.2016 NL 2017535**

(54) **AUTONOMOUS URN FOR DISCHARGING POWDERY MORTAL REMAINS FROM THE URN, AS WELL AS A METHOD FOR DISCHARGING POWDERY MORTAL REMAINS TO THE GROUND**

(57) Urn for the autonomous discharge from the urn of powdery mortal remains such as ashes. The urn comprises a housing comprising a chamber for ashes, a discharge opening for the ashes, as well as a device for the batchwise discharge of the powdery remains. For reliably discharging powdery mortal remains the device comprises

- a transport organ for conveying powdery mortal remains towards the discharge opening, and
 - a blade provided outside the housing, which blade is movable by the action of the wind;
- wherein the urn is arranged for converting wind energy into a movement of the transport organ by means of the movable blade.

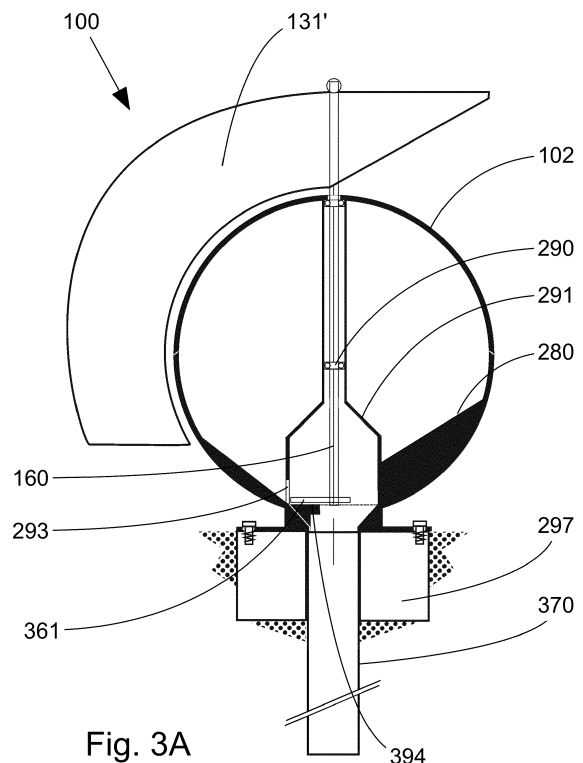

Fig. 3A

Description

[0001] The present invention relates to an urn for discharging powdery mortal remains from the urn, which urn comprises

- a housing, which housing provides a chamber for receiving the powdery mortal remains,
- a discharge opening for the powdery mortal remains, which discharge opening is in communication with the chamber, and
- a device for discharging a portion of the powdery remains.

[0002] An autonomous urn according to the preamble is known from PCT/NL2007/000006. The urn disclosed here comprises an inlet-opening for rainwater. The urn known from this publication has a device for the batch-wise discharge of the powdery remains in the form of a reservoir having a siphon. When sufficient rainwater has been collected in the reservoir, it will drain via the siphon. Powdery mortal remains in the form of ashes are then entrained by the water and discharged via the discharge opening. When the urn is arranged above a hole in the ground, the ashes will end up in the ground over time. The urn is therefore autonomous, i.e. once the urn is installed for the gradual discharge of the ashes to the ground no human intervention is required.

[0003] Although the discharge will take place gradually, as is desired, the discharge process may become disrupted as a result of which the ashes may be discharged poorly or even not be discharged at all.

[0004] The object of the present invention is to provide an urn that is suitable for a more reliable discharge of powdery mortal remains to the ground.

[0005] To this end, an urn according to the preamble is characterized in that the device comprises

- a transport organ for transporting the powdery mortal remains towards the discharge opening,
- a driving shaft for driving the transport organ, and
- a blade provided outside the housing, which blade is movable by the action of the wind;

wherein the urn is arranged for converting wind energy into a movement of the transport organ by means of the movable blade.

[0006] Powdery mortal remains are generally ashes obtained by cremation and optionally followed by grinding such as by means of a ball mill. Other methods for processing a corpse into a powdery material are known as well, such as a cryogenic method (freeze drying). For the sake of brevity only, hereinafter the term ashes will be used, without the invention being limited thereto.

[0007] Because of the use of wind energy, the urn can discharge ashes autonomously and gradually; wherein the ashes remain relatively dry, retain their ability to flow better and can be conveyed by the transport organ ef-

fectively.

[0008] According to a first possible embodiment the transport organ is a screw conveyor which at a first section of the screw conveyor is in contact (open connection) with the chamber in which ashes are present and at a second section of the screw conveyor is in communication with the discharge opening for delivering ashes to this opening. The urn may comprise a plurality of blades for directly (mechanically) or indirectly (electrically) driving an actuator. In view of the force necessary, advantageously a system for storage of electrical energy (such as a capacitor and preferably a battery) will be provided which, in case it is charged sufficiently or to a chosen degree feeds an electric motor which will drive the transport organ via a gearbox. In this way powdery mortal remains are conveyed towards the discharge opening, wherein the transport organ is driven for a predetermined period and/or until a predetermined degree of discharge of the system for storage of electrical energy.

[0009] In case of a mere mechanical drive the driving shaft will typically protrude through the housing in order to connect the blade with the transport organ, although it is also possible by means of magnets without the requirement of a hole in the housing.

[0010] According to a favourable embodiment, part of the device selected from i) an actuator for driving the transport organ, and ii) the transport organ, is housed inside the urn.

[0011] Thus, the device is partially hidden from view.

[0012] According to a favourable embodiment, the urn at the underside is arranged for connecting to a discharge conduit for discharging powdery mortal remains via the discharge opening.

[0013] Such an urn can be placed easily and, generally thereafter, be provided with the powdery mortal remains.

[0014] According to a favourable embodiment, the blade is a blade of a wind vane.

[0015] Thus, a change of the wind direction is used for moving ashes from a location onto where the ashes flowed to a location where the ashes can fall down. In particular, the transport organ will take the form of an arm that is arranged transverse to a driving shaft, for instance in the form of a flat bar or of a brush. Via an opening near the underside of the urn ashes from the chamber can flow onto a collection surface. Ashes will be discharged from this collection surface by the transport organ, allowing new ashes from the chamber pour in onto it.

[0016] According to an alternative embodiment, the urn comprises a rotor which rotor comprises a plurality of blades for converting wind into electric energy and the urn comprises an electric actuator for driving the transport organ.

[0017] Thus, an urn can be provided that can discharge powdery mortal remains to the ground on a daily basis. This can therefore also take place faster than with the known urn which works with rainwater. It is also possible to do this at regular intervals by using an electronic control unit. The actuator may be an electric motor. The actuator

may also be a hydraulic cylinder containing a working medium such as paraffin which is heated and/or cooled using the electrical energy (for instance with a Peltier-element). The working medium is preferably a super-expansive working medium of which the volumetric coefficient of expansion plotted against the temperature shows a peak, and the peak is present in a temperature range of -10°C to 60°C. Paraffin is an example of a super-expansive working medium. It is a working medium that shows a non-linear expansion of > 0.01% per°C over a (limited) temperature range, with which there is a transition point, i.e. a temperature at which the coefficient of expansion is larger than with the adjacent higher and lower temperature. The temperature-dependent expansion plotted against the temperature will then for instance show a sigmoid curve.

[0018] An example of a super-expansive working medium is water. Water is suitable since it expands when frozen. At the side of the piston, preferably a non-freezing liquid that does not mix with water such as an oil will be present, wherein the specific gravity of the non-freezing liquid and the orientation of the actuator will be chosen such that at the location of the piston non-freezing liquid is present.

[0019] Because of the use of an electric drive there is even a greater possibility to avoid that the ashes become moist since an electric passage through the housing can more easily be sealed properly than a mechanical passage.

[0020] Finally, the present invention relates to a method for discharging powdery mortal remains to the ground by means of an urn which urn comprises

- a housing, which housing provides a chamber for receiving the powdery mortal remains,
- a discharge opening for the ashes, which discharge opening is in communication with the chamber, and
- a device for discharging a portion of the powdery remains;

which method comprises the steps of, in arbitrary order

- placing the urn in the open air, and
- introducing the powdery mortal remains in the chamber of the urn; followed by the step of
- gradually discharging powdery mortal remains present in the chamber of the urn to the ground via the discharge opening;

wherein the urn is an urn according to any of the claims 1 to 5; and wind energy is converted into a movement of the transport organ by means of the blade.

[0021] Thus, the powdery mortal remains can be discharged to the ground gradually.

[0022] In the scope of the present invention "gradually" means discharging powdery mortal remains for a period of more than 1 week in either regular or irregular intervals. In practice, this period may be many months or a few

years.

[0023] The method also relates to the use of any of the subclaims of the urn in any combination which, for the sake of brevity only, have not been repeated.

[0024] The present invention will now be illustrated with reference to the drawing where

Fig. 1 shows a cross-sectional view through an embodiment of an urn according to the invention;

Fig. 2 shows a cross-sectional view of an alternative urn;

Fig. 3a shows a longitudinal sectional view by an alternative urn; and

Fig. 3b shows a horizontal cross-sectional view of the urn of Fig. 3A.

[0025] Fig. 1 shows a schematic cross-sectional view of an autonomous urn 100 according to the invention, which in the embodiment illustrated here is an urn 100 which operates based on wind energy.

[0026] The urn 100 comprises a first shell member 101, a second shell member 102 in the form of a lid which fits with the first shell member 101, which shell members together provide a housing which provides a chamber 103. The urn 100 further comprises a foot 104 provided with a mounting flange 105 with holes 106. The urn 100 comprises a discharge opening 107 via which ashes in the urn 100 can leave the urn 100 and can be released (Fig 4.) to the ground.

[0027] It can be seen that the chamber 103 is basically isolated from the environment, more particularly that the urn 100 is arranged to substantially keep rainwater falling on the urn 100 outside the chamber 103 of the urn 100. An hermetic seal is not necessary but (rain)watertight is favourable for the capability of the ashes to flow freely.

[0028] The urn 100 comprises a device 120 which comprises a wind turbine 130 provided with a small number of blades 131 (e.g. three or four) which comprise half spheres 132. The wind turbine 130 is connected to a gearbox 150 which reduces the high number of revolutions per minute of the wind turbine 130 to a large extent, for instance at least 100 times. The gearbox 150 is connected to a driving shaft 160 which protrudes through the bottom section 108 of the urn 100.

[0029] The bottom section 108 is provided with a through-opening 109 via which ashes present in the chamber 103 of the urn can flow. These will end up on a disc 161. This disc 161 is connected to the driving shaft 160 and rotates due to the wind. The disc 161 is provided with a through-hole 162.

[0030] Below the disc 161 there is a cover plate 171 which is provided with a through-opening 172 which in vertical projection does not overlap with the through-opening 109 of the bottom section 108.

[0031] The underside of the bottom section 108 is provided with a first brush ring 110 surrounding the through-opening 109. Likewise, the underside of the rotatable disc 161 is provided with a second brush ring 163 surrounding

the through-opening 162.

[0032] Ashes are gradually discharged to the ground as follows. Ashes flow from the chamber 103 onto the rotatable disc 161. The wind causes the rotatable disc 161 to rotate. The ashes that flowed from the chamber 103 onto the rotatable disc 161, are then held in place by the first brush ring 110.

[0033] When the through-opening 162 of the rotatable disc 161 under the through-opening 109 rotates, ashes retained by the first brush ring 110 will flow from the rotatable disc 161 and then fall onto the cover plate 171, where the ashes are surrounded by the second brush ring 163. When the rotatable disc 161 rotates further, it ends up at the location of the through-opening 172 in the cover plate 171, as a result of which the ashes fall through this through-opening 172 and exit the urn 100 via the discharge opening 107.

[0034] Fig. 2 shows an alternative embodiment of the urn of Fig. 1, wherein the wind turbine 130 drives a generator 231 via driving shaft 160 with which electricity is generated that is stored in battery 232. These parts, as are ball bearings 290 for the driving shaft 160, are housed in a pipe 291.

[0035] Under control of the electronic circuit 233, an electric motor 242 is actuated which drives a transport organ 140 in the form of a screw conveyor via a gearbox 150'. Thus, the ashes are conveyed from the chamber 103 via a through-opening 293 in the pipe 291 to above the discharge opening 107. Hence, the ashes can leave the urn 100.

[0036] For allowing the flow in the chamber 103 to the through-opening 293 in the pipe 291 at the bottom of the first shell member 101 a liquid mass has been provided whilst the first shell member 101 was held askew. After the solidification of the liquid mass (e.g. by cool-down/polymerizing) it can serve as guiding surface 280 (Fig. 3) for ashes. By way of example polyester resin may be used as curable mass. Of course, instead it is also possible to adapt the shape of the first shell member 101 for allowing an effective flow of the ashes to the through-opening 293 in order to empty the urn 100 substantially.

[0037] The urn 100 is shown in a mounted state, wherein the urn 100 is secured by means of bolts 296 to a socle 297. The socle 297 comprises a through-opening 298 and is located in the ground 299.

[0038] Fig. 3A shows a vertical cross-sectional view of an alternative embodiment of the urn 100. Fig. 3B shows a horizontal cross-sectional view of the urn of Fig. 3A at the location of the through-opening 293.

[0039] In this embodiment of the invention the urn 100 comprises a blade 131 in the form of a wind vane 131'. In this case, for discharging the ashes, the blade is pushed away by the wind in case of a change of the wind direction.

[0040] Via the through-opening 293 in the pipe 291 ashes flow onto a horizontal plateau 394, as a result of which the outflow of ashes from the chamber 103 will stop automatically.

[0041] The driving shaft 160 is provided with an arm 361 which pushes the ashes lying on the plateau 394 from the plateau 394 when the wind turns. This will fall on the chamfer 295 and the ashes exit the urn 100 via the discharge opening 107.

[0042] Blade 131 (i.e. wind vane 131') runs along part of the length substantially parallel to the outer circumference of the urn 100 as a result of which wind blowing around the urn 100 is used for exerting a maximum torque. Since the arm 361 is shorter than the moment arm of the wind vane 131', a relatively large force can be exerted on the ashes as a result of which the ashes can be pushed from the plateau effectively. If so desired, unlike the embodiment illustrated here, the plateau 394 may be located closer to the rotational axis of the driving shaft 160 and thus the arm 361 can be shorter, allowing an even larger force to be exerted.

[0043] Fig 3A shows a long discharge conduit 370, e.g. having a length of 1.5 m, which is introduced into the ground and to which the discharge opening 107 of the urn 100 is connected. After the insertion of the ashes, the urn 100, the socle 297 and the discharge conduit 370 can be removed and the hole in the ground 299 can be closed.

[0044] Fig. 3B shows schematically a horizontal cross-sectional view of the urn of Fig. 3A. Here the driving shaft 160 with arm 361, plateau 394, the through-opening 293 and the discharge opening 107 can be seen.

Claims

1. An urn (100) for discharging powdery mortal remains from the urn (100), which urn (100) comprises

- a housing, which housing provides a chamber (103) for receiving the powdery mortal remains,
- a discharge opening (107) for the powdery mortal remains, which discharge opening (107) is in communication with the chamber (103), and
- a device (120) for discharging a portion of the powdery remains;

characterized in that the device (120) comprises

- a transport organ (140) for transporting the powdery mortal remains towards the discharge opening (107),
- a driving shaft (160) for driving the transport organ (140), and
- a blade (131) provided outside the housing, which blade is movable by the action of the wind;

wherein the urn (100) is arranged for converting wind energy into a movement of the transport organ (140) by means of the movable blade (131).

2. The urn (100) according to claim 1, wherein part of

the device (120) selected from i) an actuator for driving the transport organ (140), and ii) the transport organ (140), is housed inside the urn (100).

3. The urn (100) according to claim 1 or 2, wherein the urn (100) at the underside is arranged for connecting to a discharge conduit (370) for discharging powdery mortal remains via the discharge opening (107). 5
4. The urn (100) according to any of the preceding claims, wherein the blade (131) is a blade (131) of a wind vane (131'). 10
5. The urn (100) according to any of the claims 1 to 3, wherein the urn (100) comprises a rotor which rotor comprises a plurality of blades (131) for converting wind into electric energy and the urn (100) comprises an electric actuator for driving the transport organ. 15
6. A method for discharging powdery mortal remains to the ground (299) by means of an urn (100) which urn (100) comprises 20

- a housing, which housing provides a chamber (103) for receiving the powdery mortal remains, 25
- a discharge opening (107) for the ashes, which discharge opening (107) is in communication with the chamber (103), and
- a device (120) for discharging a portion of the powdery remains; 30

which method comprises the steps of, in arbitrary order

- placing the urn (100) in the open air, and 35
- introducing the powdery mortal remains in the chamber (103) of the urn (100);

followed by the step of

- gradually discharging powdery mortal remains present in the chamber (103) of the urn (100) to the ground (299) via the discharge opening (107); 40

characterized in that the urn (100) is an urn (100) according to any of the claims 1 to 5; and wind energy is converted into a movement of the transport organ (140) by means of the blade (131). 45

50

55

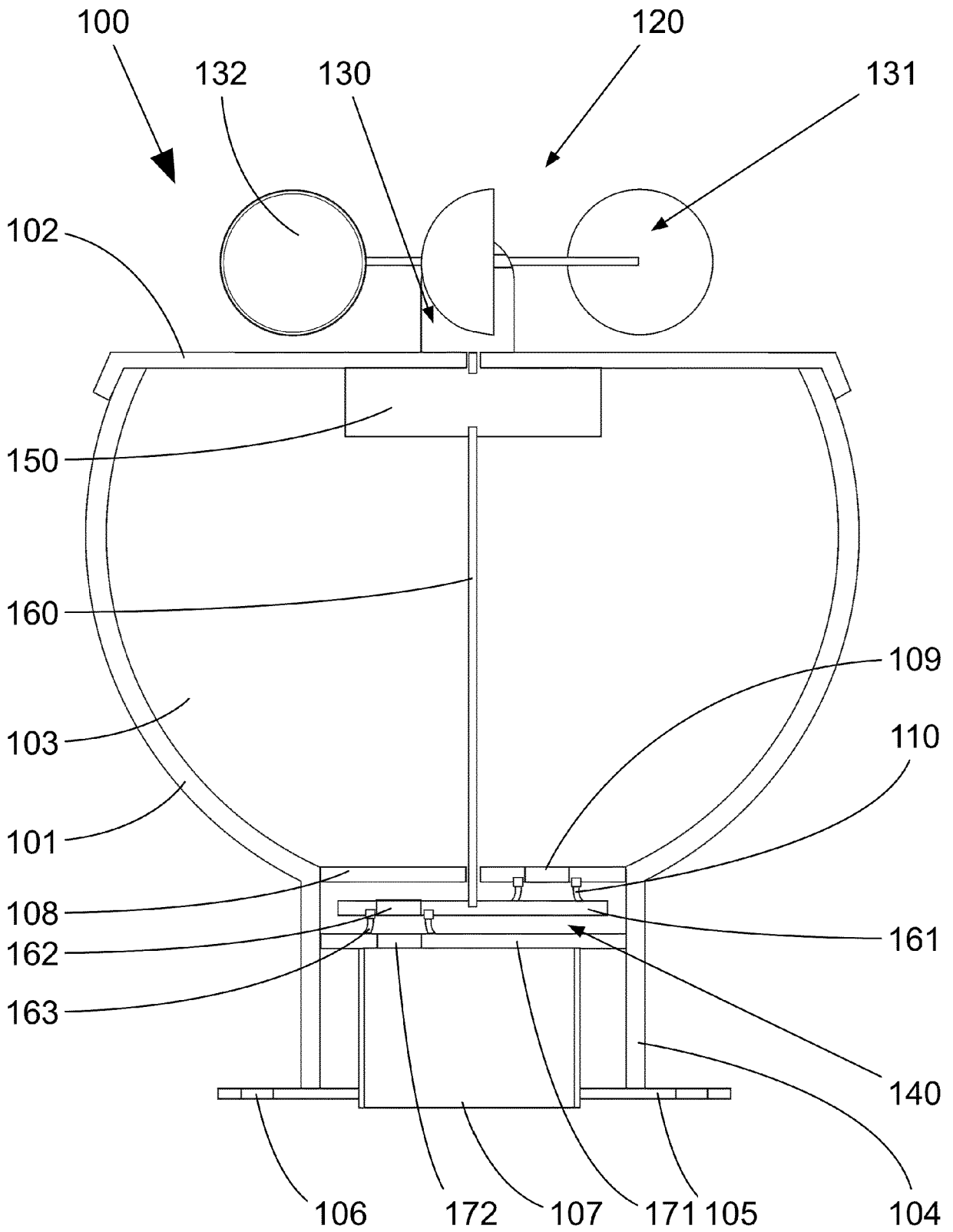

Fig. 1

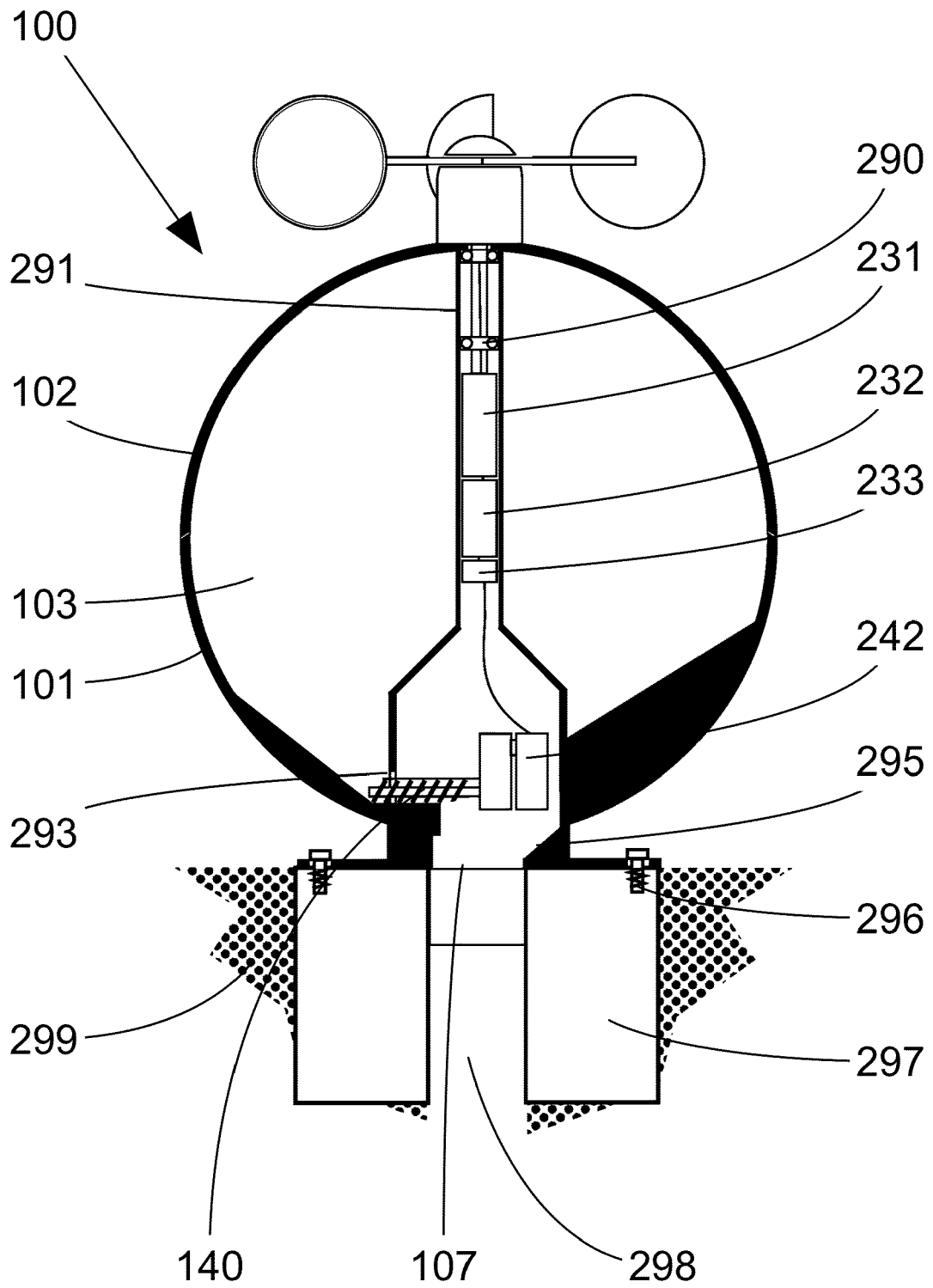
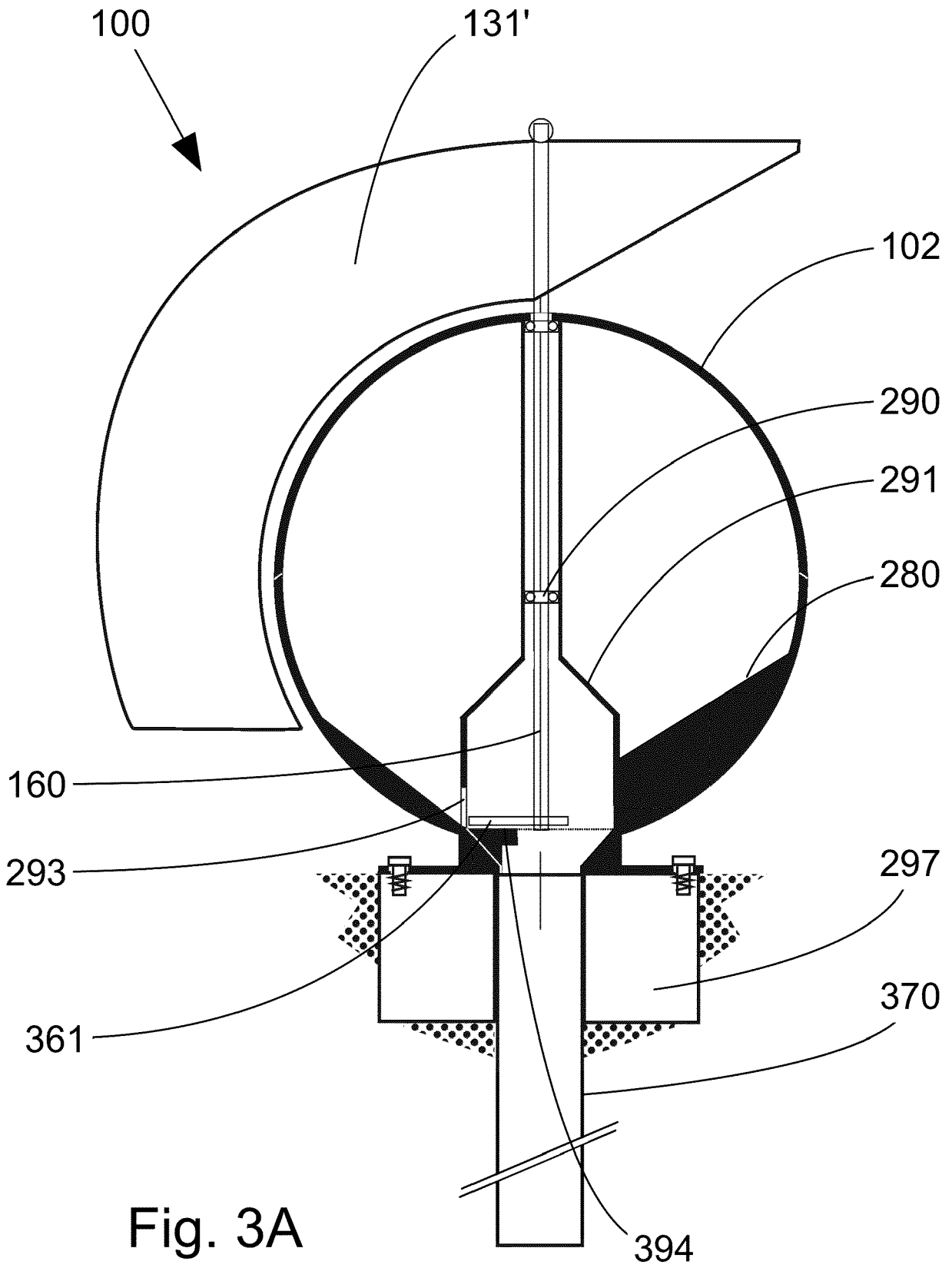

Fig. 2



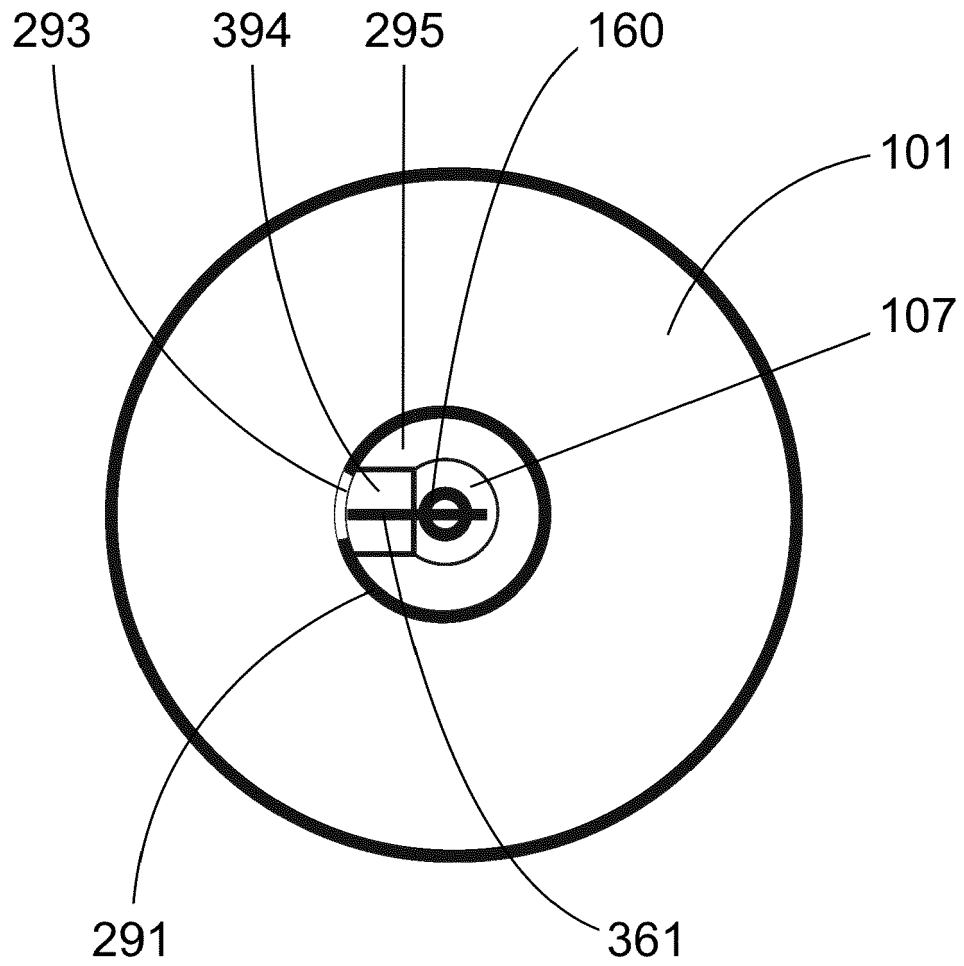

Fig. 3B



EUROPEAN SEARCH REPORT

Application Number
EP 17 19 3075

5

10

15

20

25

30

35

40

45

50

55

DOCUMENTS CONSIDERED TO BE RELEVANT			
Category	Citation of document with indication, where appropriate, of relevant passages	Relevant to claim	CLASSIFICATION OF THE APPLICATION (IPC)
A	US 2011/220733 A1 (LARSON KRIS K [US] ET AL) 15 September 2011 (2011-09-15) * paragraph [0024] - paragraph [0027] * * figures 1, 2 *	1-6	INV. A61G17/08
A	US 5 393 253 A (HUMBLE DAVID R [US] ET AL) 28 February 1995 (1995-02-28) * column 3, line 43 - column 4, line 44 * * figures 1-5 *	1-6	
			TECHNICAL FIELDS SEARCHED (IPC)
			A61G
The present search report has been drawn up for all claims			
Place of search The Hague		Date of completion of the search 15 January 2018	Examiner Ong, Hong Djien
CATEGORY OF CITED DOCUMENTS X : particularly relevant if taken alone Y : particularly relevant if combined with another document of the same category A : technological background O : non-written disclosure P : intermediate document		T : theory or principle underlying the invention E : earlier patent document, but published on, or after the filing date D : document cited in the application L : document cited for other reasons & : member of the same patent family, corresponding document	

1
EPO FORM 1503 03/82 (P04C01)

**ANNEX TO THE EUROPEAN SEARCH REPORT
ON EUROPEAN PATENT APPLICATION NO.**

EP 17 19 3075

5 This annex lists the patent family members relating to the patent documents cited in the above-mentioned European search report.
The members are as contained in the European Patent Office EDP file on
The European Patent Office is in no way liable for these particulars which are merely given for the purpose of information.

15-01-2018

Patent document cited in search report	Publication date	Patent family member(s)	Publication date
US 2011220733 A1	15-09-2011	NONE	

US 5393253 A	28-02-1995	AU 6088794 A	15-08-1994
		US 5393253 A	28-02-1995
		WO 9416940 A1	04-08-1994

EPO FORM P0459

For more details about this annex : see Official Journal of the European Patent Office, No. 12/82

REFERENCES CITED IN THE DESCRIPTION

This list of references cited by the applicant is for the reader's convenience only. It does not form part of the European patent document. Even though great care has been taken in compiling the references, errors or omissions cannot be excluded and the EPO disclaims all liability in this regard.

Patent documents cited in the description

- NL 2007000006 W [0002]