

(19)



(11)

**EP 3 315 050 B1**

(12)

**EUROPEAN PATENT SPECIFICATION**

(45) Date of publication and mention of the grant of the patent:  
**02.06.2021 Bulletin 2021/22**

(51) Int Cl.:  
**A47D 13/10** <sup>(2006.01)</sup>      **A47D 9/04** <sup>(2006.01)</sup>  
**A47C 3/03** <sup>(2006.01)</sup>      **A47D 13/06** <sup>(2006.01)</sup>  
**A47D 9/02** <sup>(2006.01)</sup>      **A47D 9/00** <sup>(2006.01)</sup>  
**A47D 1/00** <sup>(2006.01)</sup>      **A47D 1/08** <sup>(2006.01)</sup>

(21) Application number: **17188914.0**

(22) Date of filing: **31.08.2017**

(54) **CHILDREN'S MOTION DEVICE**

KINDERBEWEGUNGSVORRICHTUNG

DISPOSITIF DE MOUVEMENT POUR ENFANTS

(84) Designated Contracting States:  
**AL AT BE BG CH CY CZ DE DK EE ES FI FR GB GR HR HU IE IS IT LI LT LU LV MC MK MT NL NO PL PT RO RS SE SI SK SM TR**

(30) Priority: **15.09.2016 US 201662395158 P**

(43) Date of publication of application:  
**02.05.2018 Bulletin 2018/18**

(73) Proprietor: **Kids2, Inc.**  
**Atlanta, Georgia 30305-1712 (US)**

(72) Inventors:  
 • **POMEROY, Blake**  
**Atlanta, GA 30306 (US)**

- **BURNS, Stephen**  
**Cumming, GA 30041 (US)**
- **LANGE, Eric**  
**Atlanta, GA 30324 (US)**
- **SCLARE, Jacob**  
**Dacula, GA 30019 (US)**
- **GAMBOA, Jose**  
**Dunwoody, GA 30350 (US)**

(74) Representative: **Haseltine Lake Kempner LLP**  
**Redcliff Quay**  
**120 Redcliff Street**  
**Bristol BS1 6HU (GB)**

(56) References cited:  
**DE-U1- 8 108 262**      **US-A- 3 204 953**  
**US-A- 4 598 946**      **US-A1- 2007 090 672**

**EP 3 315 050 B1**

Note: Within nine months of the publication of the mention of the grant of the European patent in the European Patent Bulletin, any person may give notice to the European Patent Office of opposition to that patent, in accordance with the Implementing Regulations. Notice of opposition shall not be deemed to have been filed until the opposition fee has been paid. (Art. 99(1) European Patent Convention).

## Description

### Cross-Reference to Related Application

**[0001]** This application claims the benefit of U.S. Provisional Patent Application Serial No. 62/395,158 filed September 15, 2016.

### Technical Field

**[0002]** The present invention relates generally to the field of children's accessories, and more particularly to motion devices for children.

### Background

**[0003]** Various forms of children's motion devices are known for use with infants and children at different stages of their development. For example, bouncers, jumpers, rockers, seats, swings, and the like are used to provide entertainment, exercise and/or calming motion for children. Children's motion devices commonly utilize flexible metal springs or other flexible or resilient biasing elements to impart a bouncing or other cyclical type of motion. Such biasing components may suffer from a number of disadvantages, such as for example, high material costs leading to increased production expense, increased complexity of manufacturing and assembly, susceptibility to fatigue failure, loss of elasticity and material creep over time, environmental concerns with material treatment and finishing processes such as metal powder-coating, increased weight resulting in higher transport and handling costs, production and sourcing difficulties, etc. Other children's motion devices are known from US2007090672 A1, DE8108262 U1 and US3204953 A.

**[0004]** Accordingly, it can be seen that needs exist for improvements to children's motion devices. It is to the provision of improved children's motion devices meeting these and other needs that the present invention is primarily directed.

### Summary

**[0005]** In example embodiments, the present invention provides improved children's motion devices in various formats that incorporate non-metal resilient biasing elements to impart a bouncing or other cyclical type of motion. In the invention, the one or more resilient biasing elements comprise a polymeric elastomer material, such as for example a thermoplastic polyester elastomer.

**[0006]** According to a first aspect of the present invention, it is provided a children's bouncer device as claimed in claim 1. According to a second aspect of the invention, it is provided children's motion device as claimed in claim 8. In the first aspect, the present invention relates to a children's bouncer device including a base configured to support the device on a support surface, a child-supporting portion supported above the base and configured to

support a child, and at least one non-metal resilient biasing element operatively engaged between the base and the child-supporting portion to allow a bouncing motion of the child-supporting portion relative to the base.

5 The resilient biasing element includes a body formed of a polymeric elastomer material such as, for example, a thermoplastic polyester elastomer. The body preferably has a first side attached to the base, a second side attached to the child supporting portion, and at least one interconnecting member extending between the first side and the second side. The at least one interconnecting member preferably deforms elastically and resiliently and imparts a counter-biasing force on the child-supporting portion in response to the bouncing motion of the child-supporting portion. The resilient biasing element comprises a panel of the polymeric elastomer material defining a plurality of openings and forming a spaced array of support struts.

**[0007]** In the second aspect, the invention relates to a children's motion device including a base, a child-supporting portion, and at least one non-metal resilient biasing element operatively engaged between the base and the child-supporting portion to allow motion of the child-supporting portion relative to the base. The resilient biasing element comprises a molded panel of a thermoplastic polyester elastomer material defining a plurality of openings and forming a spaced array of support struts. In particular example embodiments, the thermoplastic polyester elastomer is a DuPont™ Hytrel® material.

20 **[0008]** In an example that is not part of the invention it is related to a children's jumper device including a base frame that includes a plurality of frame segments coupled to form a frame assembly, the frame assembly including lower frame legs and upper frame arms. The jumper device preferably also includes a child-supporting portion including a seat panel having an opening formed therein, and a seat sling having a pair of leg openings formed therein affixed to the seat panel and extending across and beneath the opening. The jumper device preferably also includes a plurality of non-metal resilient biasing elements suspending the child-supporting portion from the upper frame arms of the base frame and allowing a bouncing motion of the child-supporting portion relative to the base frame. The resilient biasing elements are preferably formed from a thermoplastic polyester elastomer material and are configured to elastically and resiliently deform under tension and provide a progressively increasing counter-biasing force during at least a portion of the bouncing motion of the child-supporting portion.

30 **[0009]** In another example that is not part of the invention it is related to a chair including a base, a seat portion, and an attachment bracket operatively engaged between the base and the seat portion to allow a pivotal rocking or bouncing motion of the seat portion relative to the base. The attachment bracket is preferably formed from a thermoplastic polyester elastomer material.

40 **[0010]** These and other aspects, features and advantages of the invention will be understood with reference

to the drawing figures and detailed description herein, and will be realized by means of the various elements and combinations particularly pointed out in the appended claims. It is to be understood that both the foregoing general description and the following brief description of the drawings and detailed description of example embodiments are explanatory of example embodiments of the invention, and are not restrictive of the invention, as claimed.

### Brief Description of the Drawings

#### [0011]

Figure 1A is a perspective view of a children's bouncer device according to an example embodiment of the present invention. Figures 1B, 1C and 1D show successive degrees of flexure of resilient biasing element portions through a range of motion of the bouncer device according to example form.

Figure 2A is a perspective view of a children's bouncer device according to another example embodiment of the present invention. Figures 2B, 2C and 2D show further details of the structure and operation of the bouncer device according to example form.

Figure 3 is a perspective view of a children's bouncer device according to another example embodiment of the present invention.

Figure 4A is a perspective view of a children's bouncer device according to another example embodiment of the present invention. Figure 4B shows further detail of a resilient biasing element portion of the bouncer device according to example form.

Figure 5A is a perspective view of a children's bouncer device according to another example embodiment of the present invention. Figure 5B shows further detail of a resilient biasing element portion of the bouncer device according to example form.

Figure 6A is a perspective view of a children's bouncer device according to another example embodiment of the present invention. Figure 6B shows further detail of a resilient biasing element portion of the bouncer device according to example form.

Figure 7A is a perspective view of a children's bouncer device according to another example embodiment of the present invention. Figure 7B shows an assembly view of the bouncer device constructed according to example form.

Figure 8 is a perspective view of a children's bouncer device not according to the present invention.

Figure 9 is a perspective view of a children's bouncer device not according to the present invention.

Figure 10 is a perspective view of a children's bouncer device according to another example embodiment of the present invention.

Figure 11 is a perspective view of a children's bouncer device not according to the present invention.

Figure 12 is a perspective view of a children's bounc-

er device not according to the present invention.

Figure 13 is a perspective view of a children's jumper device not according to the present invention.

Figures 14A - 14D show a sequence of folding a children's jumper device from an operational configuration to a folded configuration not according to the present invention.

### Detailed Description of Example Embodiments

[0012] The present invention may be understood more readily by reference to the following detailed description of example embodiments taken in connection with the accompanying drawing figures, which form a part of this disclosure. It is to be understood that this invention is not limited to the specific devices, methods, conditions or parameters described and/or shown herein, and that the terminology used herein is for the purpose of describing particular embodiments by way of example only and is not intended to be limiting of the claimed invention.

[0013] Also, as used in the specification including the appended claims, the singular forms "a," "an," and "the" include the plural, and reference to a particular numerical value includes at least that particular value, unless the context clearly dictates otherwise. Ranges may be expressed herein as from "about" or "approximately" one particular value and/or to "about" or "approximately" another particular value. When such a range is expressed, another embodiment includes from the one particular value and/or to the other particular value. Similarly, when values are expressed as approximations, by use of the antecedent "about," it will be understood that the particular value forms another embodiment.

[0014] With reference now to the drawing figures, wherein like reference numbers represent corresponding parts throughout the several views, Figures 1A - 1D show a children's bouncer device 10 according to an example embodiment of the present invention. The bouncer device 10 generally comprises a base 20, a child-supporting portion 40, and at least one non-metal resilient biasing element 60 operatively engaged between the base and the child-supporting portion to allow a pivotal or bouncing motion M of the child-supporting portion relative to the base.

[0015] In the depicted embodiment, the base 20 comprises a substantially rigid oval ring-shaped support platform configured to support the device 10 on a floor or other generally flat support surface. In alternate embodiments, the base 20 may have a circular, square, rectangular, polygonal, U-shaped, or other regular or irregular geometric configuration or structure. In example embodiments, the base 20 may comprise one or more base segments permanently or semi-permanently coupled together into an assembly, for example a front segment, first and second side segments, and/or a back segment; or alternatively may comprise a single unitary component. The base 20 may be constructed of a molded plastic, metal, wood, composite, and/or other structural ma-

terial(s) of construction. The base 20 may optionally comprise one or more non-slip feet or contact surface components on its lower surface, for stability and positioning on the support surface, and/or to prevent marring the support surface.

**[0016]** In example embodiments, the child-supporting portion 40 comprises a seat or support assembly configured for supporting a child therein or thereon. In the depicted embodiment, the child-supporting portion 40 includes a peripheral support ring 42 at least partially surrounding and supporting an inner sling or seat portion 44. In example embodiments, the peripheral support ring 42 comprises a substantially rigid structure, for example constructed of a molded plastic, metal, wood, composite, and/or other material(s), and the inner sling or seat portion 44 comprises a flexible and/or cushioned fabric or soft-goods construction affixed and supported at its periphery by the peripheral support ring. In example forms, the child-supporting portion comprises a headrest or head end portion 50, a seatback portion 52, a seat bottom portion 54, a footrest or foot end portion 56, and side bolsters or armrest portions 58, configured to comfortably and securely support and retain children of a range of sizes and developmental stages therein, for example ranging from infants to young children.

**[0017]** In example embodiments, at least one non-metal resilient biasing element 60 is operatively engaged between the base 20 and the child-supporting portion 40. The resilient biasing element 60 is preferably configured to enable and impart a bouncing or other cyclical type of motion (indicated by directional arrow M) to the child-supporting portion 40, along with a child seated or supported thereon, through a range of motion between a first or upper position (shown in solid lines in Figure 1) and a second or lower position (shown in broken lines), while the base 20 remains generally stationary. In example embodiments, the one or more resilient biasing elements 60 comprise molded components formed from a polymeric elastomer material, such as for example a thermoplastic polyester elastomer, providing substantial elastic resilience along a range of motion in compression and/or tension. In particular embodiments, the one or more resilient biasing elements 60 comprise a DuPont™ Hytrel® thermoplastic elastomer. In alternate embodiments, the resilient biasing elements comprise other elastomers, polymers, composites, natural or synthetic rubber, metals, woods, or other materials providing a suitable degree of elastic deformation, and resisting plastic deformation, under intended loads and over the desired range of motion. In example embodiments, the resilient biasing elements 60 may be formed by various processes, for example formed as a molded body by injection molding, blow molding or other molding technique, extruded, cast, woven, or otherwise fabricated. The configuration of the resilient biasing element 60, including without limitation the material durometer or hardness, reinforcement components, the thickness and shape of the material, and/or the location(s) of placement between the base 20 and

the child-supporting portion 40 are selected and designed depending upon parameters including the intended loading (e.g., weight range of child), and desired range of movement, speed and type of movement. In example  
5  
embodiments, the resilient biasing element 60 is formed separately from the base 20 and the child-supporting portion 40, and the components are attached by adhesive, welding or bonding, and/or one or more coupling elements or attachment members. In alternate embodi-  
10  
ments, the resilient biasing element 60 is formed together with the base 20 and the child-supporting portion 40, for example by co-molding or other fabrication process. In example embodiments, the material of the resilient biasing element 60 is of a bright or contrasting color differing  
15  
in appearance from the material of the base 20 and the child-supporting portion 40, allowing improved external visibility of its flexure and elastic deformation as the device 10 bounces when used.

**[0018]** In the depicted example embodiment, the resilient biasing element 60 comprises a curved molding or  
20  
panel of polymeric elastomer material extending along at least a portion of the front and sides of the bouncer device 10, with its lower side affixed or attached to the front portion of the base 20 and its upper side affixed or  
25  
attached to the foot end 56 of the child-supporting portion 40. One or more openings or cutout portions 65 are optionally formed in the panel of material of the resilient biasing element 60, with the remaining material of the resilient biasing element forming one or more generally  
30  
vertical ribs or upright struts, for example a plurality of ribs or struts 72, 74, 76 extending in a pair of spaced arrays along each side of the resilient biasing element, having lower ends adjacent the base 20 and upper ends adjacent the child-supporting portion 40. As seen with  
35  
reference to Figures 1C and 1D, the struts 72, 74, 76 optionally provide a progressive stiffness which increases in resistance and upward bias as the child-supporting portion 40 moves downwardly relative to the base 20, compressing successive portions of the material of the resilient biasing element 60. For example, as the child-  
40  
supporting portion 40 begins to move downwardly relative to the base 20 (Fig. 1C), the first or taller strut 72 resiliently and elastically compresses and deforms, for example buckling inwardly into contact with the second or intermediate strut 74, and providing an initial degree of upward biasing force. As the child-supporting portion 40 continues to move further downwardly relative to the base 20, the first and second struts 72, 74 resiliently and  
45  
elastically compress and deform together with an increasing degree of stiffness, for example buckling inwardly into contact with the third or shorter strut 76, and provide an additional greater degree of upward biasing force. And as the child-supporting portion 40 continues to move still further downwardly relative to the base 20  
50  
(Fig. 1D), the first, second and third struts 72, 74, 76 resiliently and elastically compress and deform together with a further increasing degree of stiffness, for example buckling inwardly into contact with a medial portion of the

resilient biasing element 60, providing an even greater degree of upward biasing force. In alternative embodiments, the resilient biasing element 60 may comprise one, two, three or more resilient struts of various configurations arranged in one, two or more spaced arrays, or the resilient biasing element may comprise a continuous solid panel or molding of polymeric elastomer material. In further alternative embodiments, the thickness, shape, location, material hardness or durometer, or other characteristics of the different struts or different sections of the resilient biasing element 60 can be selectively varied to impart desired support and motion characteristics.

**[0019]** Figures 2A, 2B, 2C and 2D show a children's bouncer device 110 according to another example embodiment of the present invention. The bouncer device 110 generally comprises a base 120, a child-supporting portion 140, and at least one non-metal resilient biasing element 160 operatively engaged between the base and the child-supporting portion to allow a pivotal or bouncing motion *M* of the child-supporting portion relative to the base. In this embodiment, the base 120 comprises a U-shaped structure having first and second side arms and an interconnecting rear cross-piece, and the child-supporting portion 140 comprises a U-shaped peripheral support member 142 having a first side arm, a second side arm, and an interconnecting head end cross-piece. Example embodiments can also include a foot end cross-piece. Ends of the first and second side arms of the base 120 are pivotally coupled to respective ends of the first and second side arms of the peripheral support member 142. The child-supporting portion 140 further comprises an inner sling or seat portion 144 supported by the peripheral support member 142, and a toy or accessory bar 146 detachably connected to the peripheral support member and extending over the child seating area. An electronic accessory 150, such as for example a vibrational unit, auto-bounce motor, audio or audiovisual device, or other entertainment feature is optionally included. The device 110 is foldable from the assembled configuration shown in Figure 2A to the folded and compact configuration shown in Figure 2D, by means of a hinged connection between the base 120 and the child-supporting portion 140. The detachable toy or accessory bar 146 optionally comprises an inner channel or groove configured to slide over and onto the back of the base 120, as shown in Figure 2D.

**[0020]** A first resilient biasing element 160 is operatively coupled in torsional engagement between a first leg of the base 120 and a first leg of the peripheral support member 142 of the child-supporting portion 140, on one side of the device 110; and a second resilient biasing element 160 is operatively coupled in torsional engagement between a second leg of the base and a second leg of the peripheral support member, on the opposite side of the device. Figure 2B shows additional details of the resilient biasing elements 160 according to an example embodiment. The resilient biasing element 160 comprises an annular body having an inner ring 162 config-

ured for cooperative engagement with a hub 122 of a mounting flange portion of the base 120, a concentric outer ring 164 configured for cooperative engagement with a sleeve 148 on the peripheral support member 142 of the child-supporting portion 140, and a plurality of ribs or fins 166 extending radially between the inner and outer rings in a circumferentially spaced array. Abutting contact surfaces of the hub 122 and inner ring 162, and of the sleeve 148 and outer ring 164, respectively, optionally include interengaging surface features for positional fixation of the components relative to one another, which are further optionally releasable and repositionable to allow selective variation of the angle of incline of the child-supporting portion 140 relative to the base 120, and for folding of the frame of the device 110. The resilient biasing element 160 and the coupled ends of the arms of the base 120 and the support member 142 are retained in position by coupling elements, such as for example a threaded mounting flange 180, bushing 182 and correspondingly threaded nut 184.

**[0021]** In example embodiments, the resilient biasing elements 160 comprise a polymeric elastomer material, such as for example a thermoplastic polyester elastomer, providing substantial elastic resilience along a range of motion in compression and/or tension. In particular embodiments, the resilient biasing elements 160 comprise a DuPont™ Hytrel® thermoplastic elastomer. The resilient biasing elements 160 provide a resilient and elastically deformable connection between the child-supporting portion 140 and the base 120, allowing the child supporting portion to move through a bouncing or otherwise cyclical motion (indicated by direction arrow *M*). As the child-supporting portion 140 moves relative to the base 120, the inner and outer rings 162, 164 of the resilient biasing elements 160 rotate concentrically relative to one another, causing the ribs or fins 166 to twist and stretch, with the elastic resilience of their constituent material imparting a rotational return bias in a direction opposite the motion of the child-supporting portion (i.e., an upward bias in response to downward motion, or a downward bias in response to upward motion). The resilient biasing elements 160 optionally provide a progressive stiffness which increases in resistance and upward bias as the child-supporting portion 140 moves downwardly relative to the base 120. In example embodiments, the ribs or fins 166 extending between the inner ring 162 and the outer ring 164 of the resilient biasing elements 160 have a varying thickness and/or stiffness along their length, for example being thinner and less stiff toward their inner ends at the points of attachment with the inner ring, and becoming progressively thicker and more stiff toward their outer ends at the points of attachment with the outer ring.

**[0022]** Figure 3 shows a children's bouncer device 210 according to another example embodiment of the present invention. The bouncer device 210 is substantially similar to the above described embodiments, with differences as noted, and generally comprises a base 220, a child-

supporting portion 240, and at least one non-metal resilient biasing element 260 operatively engaged between the base and the child-supporting portion to allow a pivotal or bouncing motion of the child-supporting portion relative to the base. In this embodiment, the resilient biasing element 260 comprises a general rectangular or square body comprising a polymeric elastomer material, such as for example a thermoplastic polyester elastomer, and in particular embodiments a DuPont™ Hytrel® thermoplastic elastomer.

**[0023]** Figures 4A and 4B show a children's bouncer device 310 according to another example embodiment of the present invention. The bouncer device 310 is substantially similar to the above described embodiments, with differences as noted, and generally comprises a base 320, a child-supporting portion 340, and at least one non-metal resilient biasing element 360 operatively engaged between the base and the child-supporting portion to allow a pivotal or bouncing motion of the child-supporting portion relative to the base. In this embodiment, the base 320 includes an upwardly extending attachment flange 322, and the child-supporting portion 340 includes inner and outer coupling hubs 342, 344 configured to receive and rotationally couple with the attachment flange of the base. Resilient biasing elements 360 are torsionally engaged between an inner hub or axle 324 extending from the attachment flange 322 of the base 320, and outer sleeves formed in the coupling hubs 342, 344. A cover panel 350 may be provided to protect against potential contact with moving parts. In example embodiments, the cover panel 350 may be transparent, and the resilient biasing elements 360 may be brightly colored or decorative, allowing external visibility of the structure and movement of the resilient biasing elements. The bouncer device 310 optionally further comprises a motor-driven or electromagnetic bounce module 370 for imparting a bouncing or other type of motion to the child-supporting portion 340 relative to the base 320.

**[0024]** Figures 5A and 5B show a children's bouncer device 410 according to another example embodiment of the present invention. The bouncer device 410 is substantially similar to the above described embodiments, with differences as noted, and generally comprises a base 420, a child-supporting portion 440, and at least one non-metal resilient biasing element 460 operatively engaged between the base and the child-supporting portion to allow a pivotal or bouncing motion of the child-supporting portion relative to the base. In this embodiment, the resilient biasing element 460 is torsionally engaged between an axle or shaft 424 connected to the base 420 and a sleeve or channel formed through a pivotally connected coupling portion of the child-supporting portion 440. A cover panel 470, optionally transparent, may be provided over the resilient biasing element 460.

**[0025]** Figures 6A and 6B show a children's bouncer device 510 according to another example embodiment of the present invention. The bouncer device 510 is substantially similar to the above described embodiments,

with differences as noted, and generally comprises a base 520, a child-supporting portion 540, and at least one non-metal resilient biasing element 560 operatively engaged between the base and the child-supporting portion to allow a pivotal or bouncing motion of the child-supporting portion relative to the base. In this embodiment, the child-supporting portion 540 comprises an electronic entertainment module 550. An adjustment actuator or switch 565 allows folding or positional adjustment of the incline angle of the child-supporting portion 540 relative to the base 520, and/or allow selective adjustment of the stiffness of the resilient biasing element 560, and/or the bouncing speed and/or range of motion of the child-supporting portion relative to the base. A cover panel 570, optionally transparent, may be provided over the resilient biasing element 560.

**[0026]** Figures 7A and 7B show a children's bouncer device 610 according to another example embodiment of the present invention. The bouncer device 610 is substantially similar to the above described embodiments, with differences as noted, and generally comprises a base 620, a child-supporting portion 640, and at least one non-metal resilient biasing element 660 operatively engaged between the base and the child-supporting portion to allow a pivotal or bouncing motion of the child-supporting portion relative to the base. In this embodiment, the base 620 comprises first and second panels 622, 624 secured together by a plurality of snap couplings. The child-supporting portion 640 comprises a lower support body 642 and an upper support body 644, configured to engage a soft-goods sling or support seat panel 646 therebetween, and a plurality of cushioned seat and armrest inserts 648, 650. The resilient biasing element 660 comprises a lower panel for attachment to the base 620, an upper panel for attachment to the child-supporting portion 640, and a plurality of ribs or struts extending between the lower and upper panels in a spaced array. In example embodiments, the resilient biasing element 660 is configured to allow front-to-back, side-to-side, and/or twisting movement of the child-supporting portion 640 relative to the base 620.

**[0027]** Figure 8 shows a children's bouncer device 710. The bouncer device 710 is substantially similar to the above described embodiments, with differences as noted, and generally comprises a base 720, a child-supporting portion 740, and at least one non-metal resilient biasing element 760 operatively engaged between the base and the child-supporting portion to allow a pivotal or bouncing motion of the child-supporting portion relative to the base. In this embodiment, the resilient biasing element 760 comprises a continuous curved web of polymeric elastomer material, such as for example a thermoplastic polyester elastomer, and in particular embodiments a DuPont™ Hytrel® thermoplastic elastomer, extending between front and side portions of the base 720 and the child-supporting portion 740.

**[0028]** Figure 9 shows a children's bouncer device 810. The bouncer device 810 is substantially similar to the

above described embodiments, with differences as noted, and generally comprises a base 820, a child-supporting portion 840, and at least one non-metal resilient biasing element 860 operatively engaged between the base and the child-supporting portion to allow a pivotal or bouncing motion of the child-supporting portion relative to the base. In this embodiment, the resilient biasing element 860 comprises a body formed as a unitary molding formed of a polymeric elastomer material, having lower web portions 862 that form a portion of the base 820, an upper panel portion 864 that forms a portion of the child-supporting portion 840, and intermediate elastically resilient flexure webs 866 extending between the lower web portions and the upper panel portion.

**[0029]** Figure 10 shows a children's bouncer device 910 according to another example embodiment of the present invention. The bouncer device 910 is substantially similar to the above described embodiments, with differences as noted, and generally comprises a base 920, a child-supporting portion 940, and at least one non-metal resilient biasing element 960 operatively engaged between the base and the child-supporting portion to allow a pivotal or bouncing motion of the child-supporting portion relative to the base. In this embodiment, the resilient biasing element 960 comprises a molding formed of a polymeric elastomer material, having lower web portions 962 that attach to the base 920, an upper flange 964 that attach to the child-supporting portion 940, and intermediate elastically resilient flexure arms 966 extending between the lower web portions and the upper flange portion.

**[0030]** Figure 11 shows a children's bouncer device 1010. The bouncer device 1010 is substantially similar to the above described embodiments, with differences as noted, and generally comprises a base 1020, a child-supporting portion 1040, and at least one non-metal resilient biasing element 1060 operatively engaged between the base and the child-supporting portion to allow a pivotal or bouncing motion of the child-supporting portion relative to the base. In this embodiment, the resilient biasing element 1060 comprises a molding formed of a polymeric elastomer material, having lower attachment portions 1062 that attach to the base 1020, an upper engagement section 1064 that attach to the child-supporting portion 1040, and intermediate elastically resilient flexure panels 1066 extending between the lower web portions and the upper flange portion.

**[0031]** Figure 12 shows a chair or bouncer device 1110. The chair or bouncer device 1110 is substantially similar to the above described embodiments, with differences as noted, and generally comprises a base 1120 having a plurality of legs 1122, a seat portion 1140, and at least one non-metal resilient biasing element 1160 operatively engaged between the base and the seat portion to allow a pivotal rocking or bouncing motion of the seat portion relative to the base. In this embodiment, the resilient biasing element 1160 comprises an attachment bracket formed of a polymeric elastomer material such

as for example a thermoplastic polyester elastomer, and in particular embodiments a DuPont™ Hytrel® thermoplastic elastomer. The attachment bracket 1160 optionally extends axially along a central spine area of the lower seat and seatback portions of the seat 1140, and allows the sections of the seat to resiliently and elastically flex and move with respect to one another. The attachment bracket 1160 is optionally rotationally coupled to a mounting hub on the base 1120, allowing the seat 1140 to rotate or spin relative to the base. Optionally, the legs 1122 comprise feet 1124 or casters at their lower ends, to support the chair or bouncer device 1110 in a fixed position or allow rolling along a support surface. A toy or accessory bar 1170 is optionally provided, extending over the seating area, and supporting one or more toys, lights, electronic devices, audiovisual displays, or other accessories.

**[0032]** Figure 13 shows a children's jumper device 1210. The jumper device 1210 generally comprises a base 1220, a child-supporting portion 1240, and at least one non-metal resilient biasing element 1260 operatively engaged between the base and the child-supporting portion to allow a bouncing and/or swinging motion of the child-supporting portion relative to the base. The base 1220 comprises a frame formed from an assembly of frame elements such as tubular sections of aluminum, steel, plastic, wood or other metals, polymers, composites or other materials. In the depicted example, the base frame 1220 comprises first and second generally downwardly extending U-shaped lower frame legs 1222, 1224, first and second generally upwardly extending U-shaped upper frame arms 1226, 1228, two upper frame arm couplings 1230 pivotally connecting respective ends of the upper frame arms, and four lower frame leg couplings 1232 pivotally connecting ends of the lower frame legs to medial portions of the upper frame arms. Slip-resistant or anti-marring feet 1234 are optionally provided along lower surfaces of the lower frame legs 1222, 1224. The child-supporting portion 1240 comprises a seat panel 1242 having an opening formed therein, and a seat sling 1244 having a pair of leg openings formed therein affixed to the seat panel and extending across and beneath the opening. Optionally, one or more toys or accessories are provided on the seat panel 1242.

**[0033]** The resilient biasing elements 1260 preferably comprise cords or bands of a polymeric elastomer material such as for example a thermoplastic polyester elastomer, and in particular embodiments a DuPont™ Hytrel® thermoplastic elastomer. In example embodiments, the resilient biasing elements 1260 comprise moldings formed by injection molding, blow molding or other molding processes, or are extruded, braided, woven or otherwise fabricated. First or upper ends of the resilient biasing cords 1260 are attached to upper cross-members of the upper frame arms 1226, 1228 adjacent upper corners of the device 1210, and second or lower ends of the resilient biasing cords are attached to the sides of the seat panel 1242. In alternate embodiments,

the resilient biasing cords extend through the top of the seat panel. The resilient biasing cords 1260 may be provided in spaced arrays of two or more cords, for example in the depicted embodiment, four arrays of three cords each are provided, one array connected at each corner of the seat panel 1242. In alternative embodiments, fewer or more resilient biasing cords per array, and/or fewer or more arrays of cords may be provided.

**[0034]** Figure 14A shows a children's jumper device 1310. The jumper device 1310 generally comprises a base 1320, a child-supporting portion 1340, and at least one non-metal resilient biasing element 1360 operatively engaged between the base and the child-supporting portion to allow a bouncing and/or swinging motion of the child-supporting portion relative to the base. The base 1320 comprises a frame formed from an assembly of frame elements such as tubular sections of aluminum, steel, plastic, wood or other metals, polymers, composites or other materials. In the depicted example, the base frame 1320 comprises first and second generally downwardly extending U-shaped lower frame legs 1322, 1324, first and second generally upwardly extending U-shaped upper frame arms 1326, 1328, and two cross-frame couplings 1330 pivotally connecting the ends of the upper frame arms and the lower frame legs. The child-supporting portion 1340 comprises a seat panel 1342 having an opening formed therein, and a seat sling 1344 having a pair of leg openings formed therein affixed to the seat panel and extending across and beneath the opening.

**[0035]** The resilient biasing elements 1360 preferably comprise cords or bands of a molded polymeric elastomer material such as for example a thermoplastic polyester elastomer, and in particular embodiments a DuPont™ Hytrel® thermoplastic elastomer. First or upper ends of the resilient biasing cords 1360 are attached to upper cross-members of the upper frame arms 1326, 1328 adjacent upper corners of the device 1310, and second or lower ends of the resilient biasing cords are attached to the sides of the seat panel 1342. The resilient biasing cords 1360 may be provided in spaced arrays of two or more cords, for example in the depicted embodiment, four arrays of three cords each are provided, one array connected at each corner of the seat panel 1342. In alternative embodiments, fewer or more resilient biasing cords per array, and/or fewer or more arrays of cords may be provided. The resilient biasing cords 1360 may be detachably coupled to the upper cross-members of the upper frame arms 1326, 1328 by tube clips or brackets 1380 having a hooked coupling portion configured to securely engage the frame arms when the device 1310 is in use with a child seated therein, but to be detached by application of moderate hand pressure by an adult caregiver when the device is not in use and a child is not seated therein.

**[0036]** A sequence of folding the children's jumper device 1310 is depicted in Figures 14A - 14D. As shown in Figure 14A - 14B, the tube clips 1380 are detached from one of the upper frame arms 1326 or 1328. The tube clips

may remain attached to the other upper frame arm. The child-supporting portion 1340 is then free to move away from the detached upper frame arm, and does not interfere with its folding. The adult caregiver actuates a frame release actuator 1332 on one or both cross-frame couplings 1330, which releases the upper frame arms 1326, 1328 to be folded toward one another (Figure 14C), and releases the lower frame legs 1322, 1324 to be folded toward one another (Figure 14D). In the folded configuration, the upper frame arms 1326, 1328, lower frame legs 1322, 1324, and child-supporting portion 1340 are generally aligned with one another in a flat and compact configuration for ease of transport or storage.

**[0037]** In use, a child is placed into or onto the child supporting portion of a children's motion device according to example embodiments of the invention, and a bouncing or other cyclical movement of the child supporting portion is imparted by manual application of force by an adult caregiver, by movement of the child, by an electronic motor-driven or electromagnetic auto-bouncer unit, and/or by other means. As the child supporting portion is moved in a first direction, the one or more non-metal resilient biasing elements of the device elastically and resiliently extend or contract out of equilibrium, either in tension or compression between the child supporting portion and the base. The shape-memory or elastic resilience of the material of the one or more non-metal resilient biasing elements causes the biasing elements to apply a biasing force to the child supporting portion, counter to the direction of motion of the child supporting portion. The counter-biasing force increases as the child supporting portion moves further out of its equilibrium position, until it balances and overcomes the momentum of the motion, causing the child supporting portion to reverse direction and move in an opposite second direction. The range of motion may then cycle back and forth in a bouncing, swinging or other form, providing entertainment, exercise, and/or soothing movement to a child supported in the motion device.

**[0038]** While the invention has been described with reference to example embodiments, it will be understood by those skilled in the art that a variety of modifications, additions and deletions are within the scope of the invention, as defined by the following claims.

## Claims

1. A children's bouncer device (10) comprising:

- a base (20) configured to support the device on a support surface;
- a child-supporting portion (40) supported above the base (20) and configured to support a child; and
- at least one non-metal resilient biasing element (60) operatively engaged between the base (20) and the child-supporting portion (40) to allow a

- bouncing motion of the child-supporting portion (40) relative to the base (20), wherein the resilient biasing element (60) comprises a body formed of a polymeric elastomer material, the body comprising a first side attached to the base (20), a second side attached to the child supporting portion (40), and at least one interconnecting member extending between the first side and the second side, wherein the at least one interconnecting member elastically and resiliently deforms and imparts a counter-biasing force on the child-supporting portion (40) in response to the bouncing motion, **characterised in that** the resilient biasing element (60) comprises a panel of the polymeric elastomer material defining a plurality of openings (65) and forming a spaced array of support struts (72, 74, 76).
2. The children's bouncer device (10) of claim 1, wherein the spaced array of support struts (72, 74, 76) elastically and resiliently deform under compression and provide a progressively increasing stiffness during at least a portion of the bouncing motion.
  3. The children's bouncer device (10) of claim 1 or 2, wherein the spaced array of support struts (72, 74, 76) comprise struts of progressively increasing height.
  4. The children's bouncer device (10) of any preceding claim, wherein the resilient biasing element comprises an annular body comprising an inner ring (162), an outer ring (164), and a plurality of fins (166) extending between the inner (162) and outer rings (164) in a circumferentially spaced array.
  5. The children's bouncer device (10) of claim 4, wherein the plurality of fins (166) define a length between the inner (162) and outer rings (164), and have a varying thickness or stiffness along their length.
  6. The children's bouncer device (10) of any preceding claim, wherein the polymeric elastomer material of the resilient biasing element (60) comprises a thermoplastic polyester elastomer material.
  7. The children's bouncer device (10) of any preceding claim, wherein the child-supporting portion (40) is repositionable relative to the base (20) for folding or adjustment of an incline angle of the child-supporting portion (40).
  8. A children's motion device (10) comprising a base (20), a child-supporting portion (40), and at least one non-metal resilient biasing element (60) operatively engaged between the base (20) and the child-supporting portion (40) to allow motion of the child-supporting portion (40) relative to the base (20), **characterised in that** the resilient biasing element (60) comprises a molded panel of a thermoplastic polyester elastomer material defining a plurality of openings and forming a spaced array of support struts.
  9. The children's motion device (10) of claim 8, wherein the spaced array of support struts (72, 74, 76) elastically and resiliently deform under compression and provide a progressively increasing stiffness during at least a portion of the motion of the child-supporting portion (40).
  10. The children's motion device (10) of claim 8 or 9, wherein the spaced array of support struts (72, 74, 76) comprise struts of progressively increasing height.
  11. The children's motion device (10) of any of claims 8 to 10, wherein the resilient biasing element (60) further comprises an annular body comprising an inner ring, an outer ring, and a plurality of fins extending between the inner and outer rings in a circumferentially spaced array.
  12. The children's motion device (10) of claim 11, wherein the plurality of fins define a length between the inner and outer rings, and have a varying thickness or stiffness along their length.

#### Patentansprüche

1. Kinderschaukelvorrichtung (10), Folgendes umfassend:

eine Basis (20), die dazu ausgelegt ist, die Vorrichtung auf einer Trägerfläche zu lagern;  
 einen Kindertragabschnitt (40), der über der Basis (20) gelagert und dazu ausgelegt ist, ein Kind zu tragen; und mindestens ein nichtmetallisches, federndes Vorspannungselement (60), das zwischen der Basis (20) und dem Kindertragabschnitt (40) wirkverbunden ist, um eine Schaukelbewegung des Kindertragabschnitts (40) in Bezug zur Basis (20) zuzulassen, wobei das federnde Vorspannungselement (60) einen Korpus umfasst, der aus einem polymeren Elastomer material ausgebildet ist, wobei der Korpus eine erste Seite, die an der Basis (20) befestigt ist, eine zweite Seite, die am Kindertragabschnitt (40) befestigt ist, und mindestens ein Verbindungselement, das sich zwischen der ersten Seite und der zweiten Seite erstreckt, umfasst, wobei sich das mindestens eine Verbindungselement elastisch und federnd verformt und als Reaktion auf die Schaukelbewegung eine Gegenvorspannungskraft auf den Kindertragabschnitt (40) aufbringt, **dadurch gekennzeichnet**

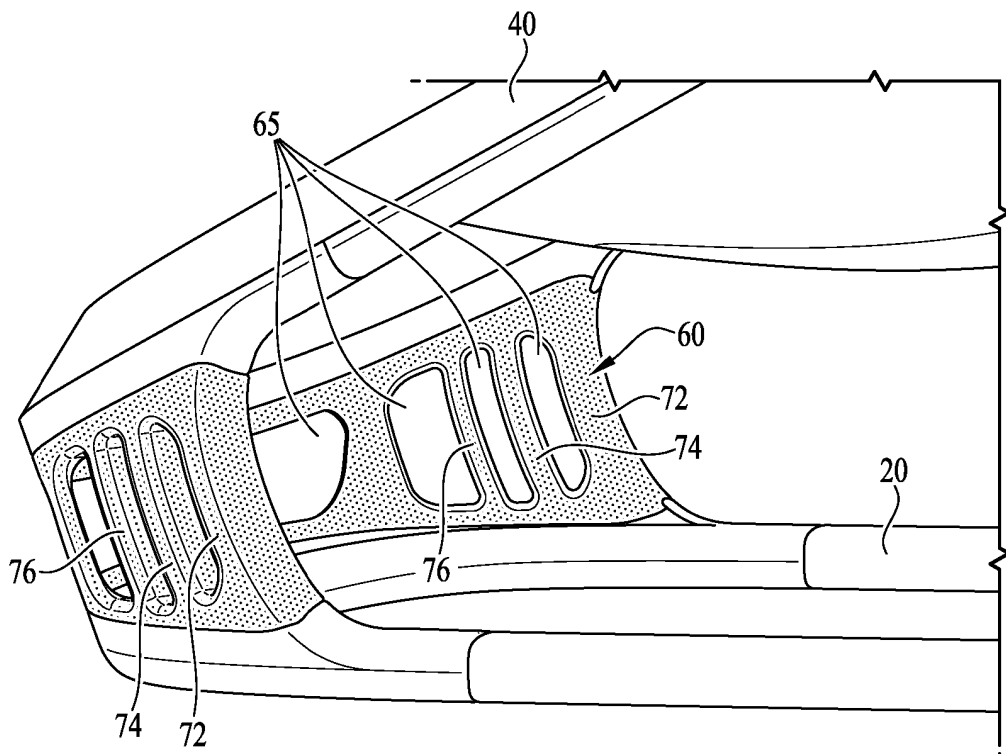
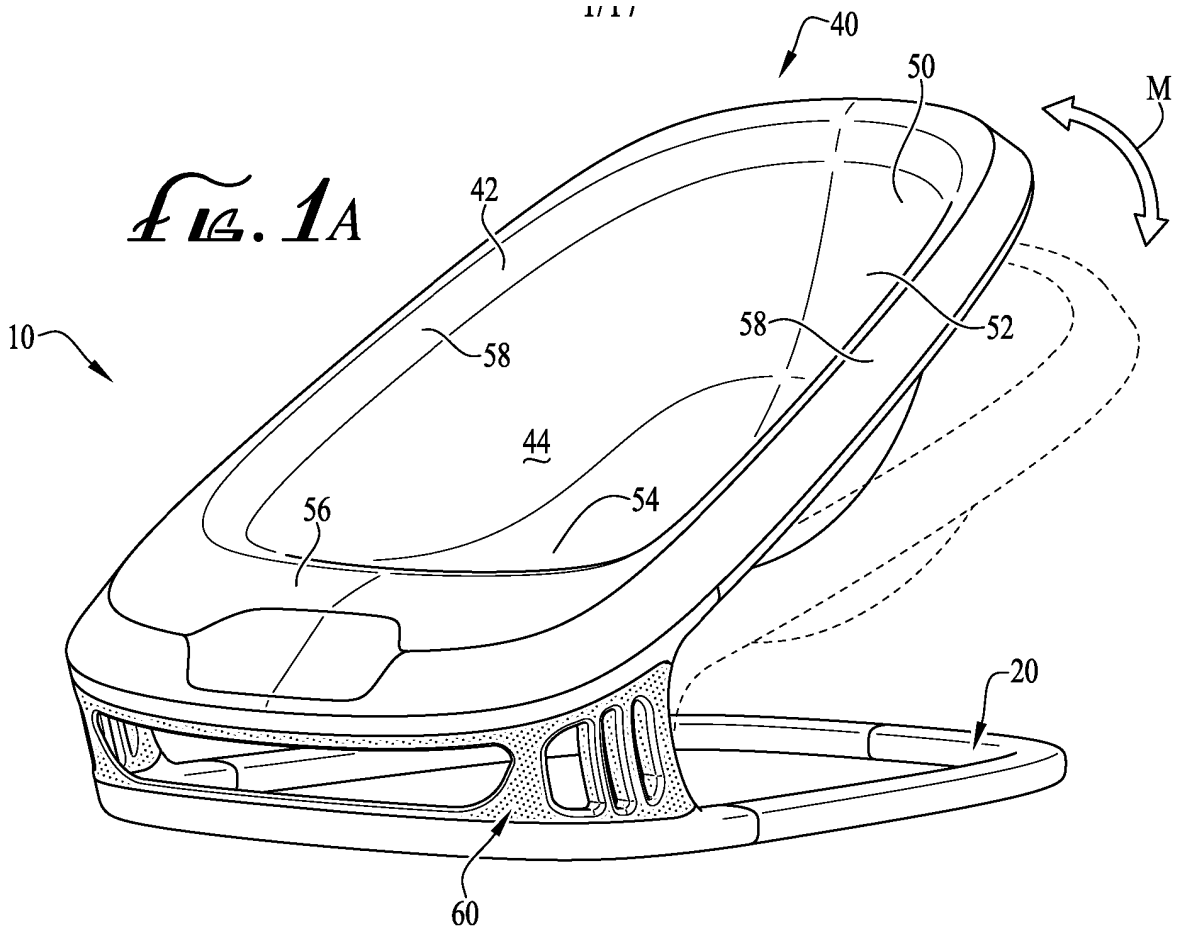
- zeichnet, dass** das federnde Vorspannungselement (60) ein Paneel aus dem polymeren Elastomermaterial umfasst, das mehrere Öffnungen (65) definiert und eine beabstandete Anordnung von Stützstreben (72, 74, 76) ausbildet.
2. Kinderschaukelvorrichtung (10) nach Anspruch 1, wobei sich die beabstandete Anordnung von Stützstreben (72, 74, 76) beim Zusammendrücken elastisch und federnd verformt und eine schrittweise zunehmende Steifigkeit während zumindest eines Teils der Schaukelbewegung vorsieht.
  3. Kinderschaukelvorrichtung (10) nach Anspruch 1 oder 2, wobei die beabstandete Anordnung von Stützstreben (72, 74, 76) Streben mit schrittweise zunehmender Höhe umfasst.
  4. Kinderschaukelvorrichtung (10) nach einem der vorstehenden Ansprüche, wobei das federnde Vorspannungselement einen ringförmigen Körper umfasst, der einen Innenring (162), einen Außenring (164) und mehrere Lamellen (166), die sich zwischen dem Innen- (162) und Außenring (164) in einer umlaufend beabstandeten Anordnung erstrecken, umfasst.
  5. Kinderschaukelvorrichtung (10) nach Anspruch 4, wobei die mehreren Lamellen (166) eine Länge zwischen dem Innen- (162) und Außenring (164) definieren und eine variierende Stärke oder Steifigkeit entlang ihrer Länge aufweisen.
  6. Kinderschaukelvorrichtung (10) nach einem der vorstehenden Ansprüche, wobei das polymere Elastomermaterial des federnden Vorspannungselements (60) ein thermoplastisches Polyesterelastomermaterial umfasst.
  7. Kinderschaukelvorrichtung (10) nach einem der vorstehenden Ansprüche, wobei der Kindertragabschnitt (40) in Bezug zur Basis (20) zum Zusammenklappen oder Anpassen eines Neigungswinkels des Kindertragabschnitts (40) neu anordenbar ist.
  8. Kinderbewegungsvorrichtung (10), eine Basis (20), einen Kindertragabschnitt (40) und mindestens ein nichtmetallisches federndes Vorspannungselement (60), das zwischen der Basis (20) und dem Kindertragabschnitt (40) wirkverbunden ist, um die Bewegung des Kindertragabschnitts (40) in Bezug zur Basis (20) zuzulassen, umfassend, **dadurch gekennzeichnet, dass** das federnde Vorspannungselement (60) ein geformtes Paneel aus einem thermoplastischen Polyesterelastomermaterial umfasst, das mehrere Öffnungen definiert und eine beabstandete Anordnung von Stützstreben ausbildet.
  9. Kinderbewegungsvorrichtung (10) nach Anspruch 8, wobei sich die beabstandete Anordnung von Stützstreben (72, 74, 76) beim Zusammendrücken elastisch und federnd verformt und eine schrittweise zunehmende Steifigkeit während zumindest eines Teils der Bewegung des Kindertragabschnitts (40) vorsieht.
  10. Kinderbewegungsvorrichtung (10) nach Anspruch 8 oder 9, wobei die beabstandete Anordnung von Stützstreben (72, 74, 76) Streben mit schrittweise zunehmender Höhe umfasst.
  11. Kinderbewegungsvorrichtung (10) nach einem der Ansprüche 8 bis 10, wobei das federnde Vorspannungselement (60) ferner einen ringförmigen Körper umfasst, der einen Innenring, einen Außenring und mehrere Lamellen, die sich zwischen dem Innen- und Außenring in einer umlaufend beabstandeten Anordnung erstrecken, umfasst.
  12. Kinderbewegungsvorrichtung (10) nach Anspruch 11, wobei die mehreren Lamellen eine Länge zwischen dem Innen- und Außenring definieren und eine variierende Stärke und Steifigkeit entlang ihrer Länge aufweisen.

#### Revendications

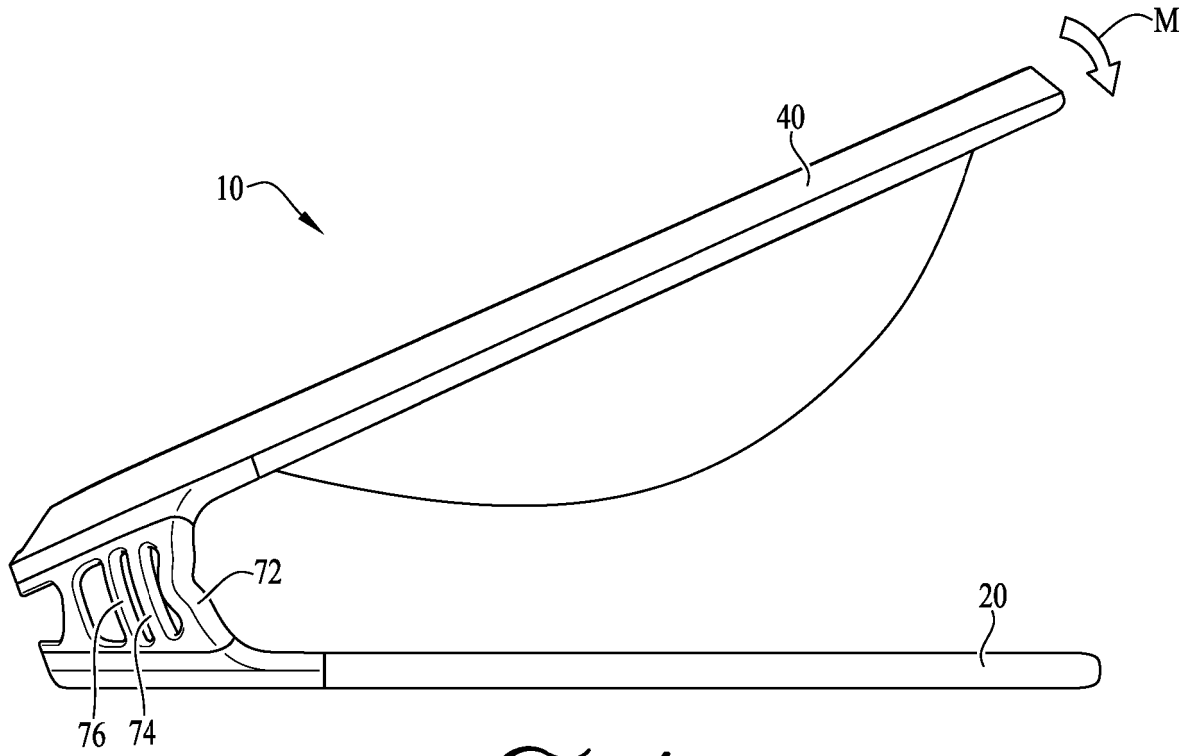
1. Dispositif de type transat (10) pour enfant, comprenant :

une base (20) configurée pour supporter le dispositif sur une surface de support ;  
 une portion de support d'enfant (40) supportée au-dessus de la base (20) et configurée pour supporter un enfant ; et  
 au moins un élément de sollicitation résilient non métallique (60) en prise fonctionnelle entre la base (20) et la portion de support d'enfant (40) pour permettre un mouvement de rebond de la portion de support d'enfant (40) par rapport à la base (20), l'élément de sollicitation résilient (60) comprenant un corps formé d'un matériau en polymère élastomère, le corps comprenant un premier côté attaché à la base (20), un deuxième côté attaché à la portion de support d'enfant (40) et au moins un organe d'interconnexion s'étendant entre le premier côté et le deuxième côté, l'au moins un organe d'interconnexion se déformant élastiquement et de manière résiliente et fournissant une force de sollicitation antagoniste à la portion de support d'enfant (40) en réponse au mouvement de rebond, **caractérisé en ce que** l'élément de sollicitation résilient (60) comprend un panneau de matériau en polymère élastomère définissant une pluralité d'ouvertu-

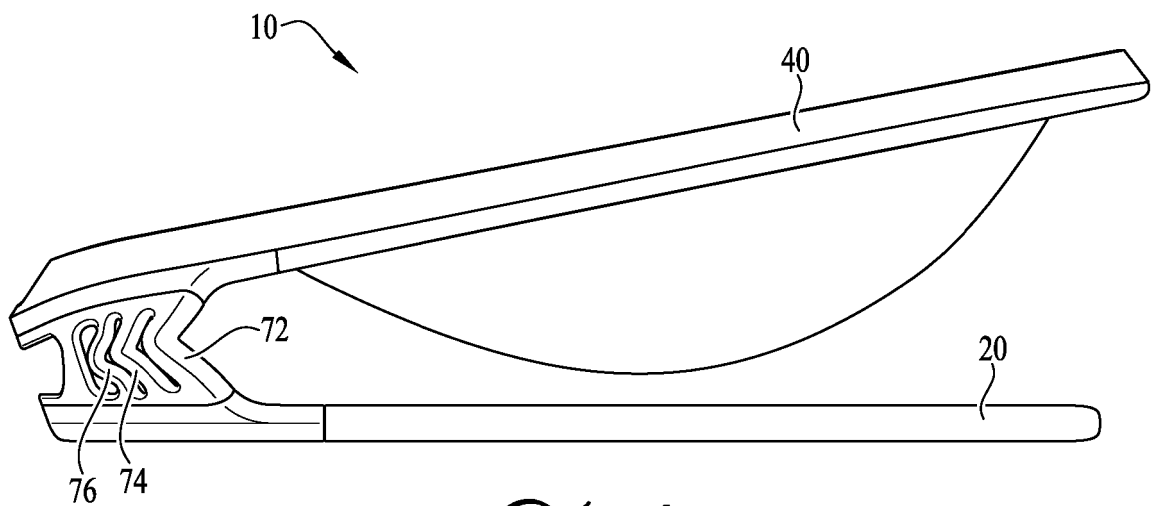
- res (65) et formant un agencement espacé d'entretoises de support (72, 74, 76).
2. Dispositif de type transat (10) pour enfant selon la revendication 1, dans lequel l'agencement espacé d'entretoises de support (72, 74, 76) se déforme élastiquement et de manière résiliente sous l'effet de la compression et développe une rigidité progressivement croissante au cours d'au moins une portion du mouvement de rebond. 5
  3. Dispositif de type transat (10) pour enfant selon la revendication 1 ou 2, dans lequel l'agencement espacé d'entretoises support (72, 74, 76) comprend des entretoises de hauteur progressivement croissante. 10
  4. Dispositif de type transat (10) pour enfant selon l'une quelconque des revendications précédentes, dans lequel l'élément de sollicitation résilient comprend un corps annulaire comprenant une bague intérieure (162), une bague extérieure (164), et une pluralité d'aillettes (166) s'étendant entre les bagues intérieure (162) et extérieure (164), suivant un agencement espacé circonférentiellement. 15
  5. Dispositif de type transat (10) pour enfant selon la revendication 4, dans lequel la pluralité d'aillettes (166) définissent une longueur entre les bagues intérieure (162) et extérieure (164) et présentent une épaisseur ou une rigidité variable le long de leur longueur. 20
  6. Dispositif de type transat (10) pour enfant selon l'une quelconque des revendications précédentes, dans lequel le matériau en polymère élastomère de l'élément de sollicitation résilient (60) comprend un matériau en polyester élastomère thermoplastique. 25
  7. Dispositif de type transat (10) pour enfant selon l'une quelconque des revendications précédentes, dans lequel la portion de support d'enfant (40) peut être repositionnée par rapport à la base (20) pour replier ou ajuster un angle d'inclinaison de la portion de support d'enfant (40). 30
  8. Dispositif de mouvement (10) pour enfant, comprenant une base (20), une portion de support d'enfant (40) et au moins un élément de sollicitation résilient non métallique (60) en prise fonctionnelle entre la base (20) et la portion de support d'enfant (40) pour permettre un mouvement de la portion de support d'enfant (40) par rapport à la base (20), **caractérisé en ce que** l'élément de sollicitation résilient (60) comprend un panneau moulé en matériau polyester élastomère thermoplastique définissant une pluralité d'ouvertures et formant un agencement espacé d'entretoises de support. 35
  9. Dispositif de mouvement (10) pour enfant selon la revendication 8, dans lequel l'agencement espacé d'entretoises de support (72, 74, 76) se déforme élastiquement et de manière résiliente sous l'effet de la compression et développe une rigidité progressivement croissante au cours d'au moins une portion du mouvement de la portion de support d'enfant (40). 40
  10. Dispositif de mouvement (10) pour enfant selon la revendication 8 ou 9, dans lequel l'agencement espacé d'entretoises de support (72, 74, 76) comprend des entretoises de hauteur progressivement croissante. 45
  11. Dispositif de mouvement (10) pour enfant selon l'une quelconque des revendications 8 à 10, dans lequel l'élément de sollicitation résilient (60) comprend en outre un corps annulaire comprenant une bague intérieure, une bague extérieure et une pluralité d'aillettes s'étendant entre les bagues intérieure et extérieure suivant un agencement espacé circonférentiellement. 50
  12. Dispositif de mouvement (10) pour enfant selon la revendication 11, dans lequel la pluralité d'aillettes définissent une longueur entre les bagues intérieure et extérieure et présentent une épaisseur ou une rigidité variable le long de leur longueur. 55



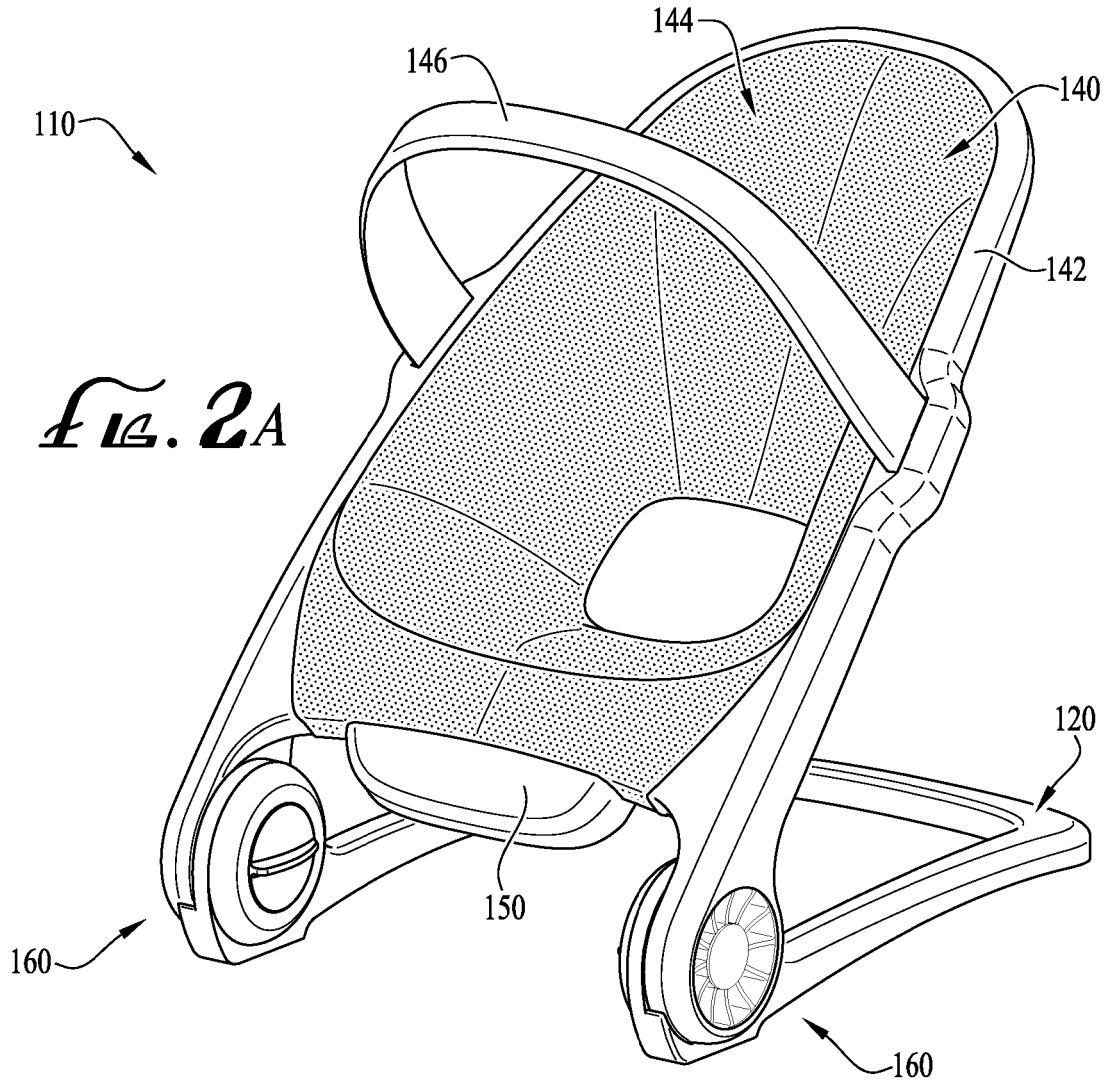
*FIG. 1B*



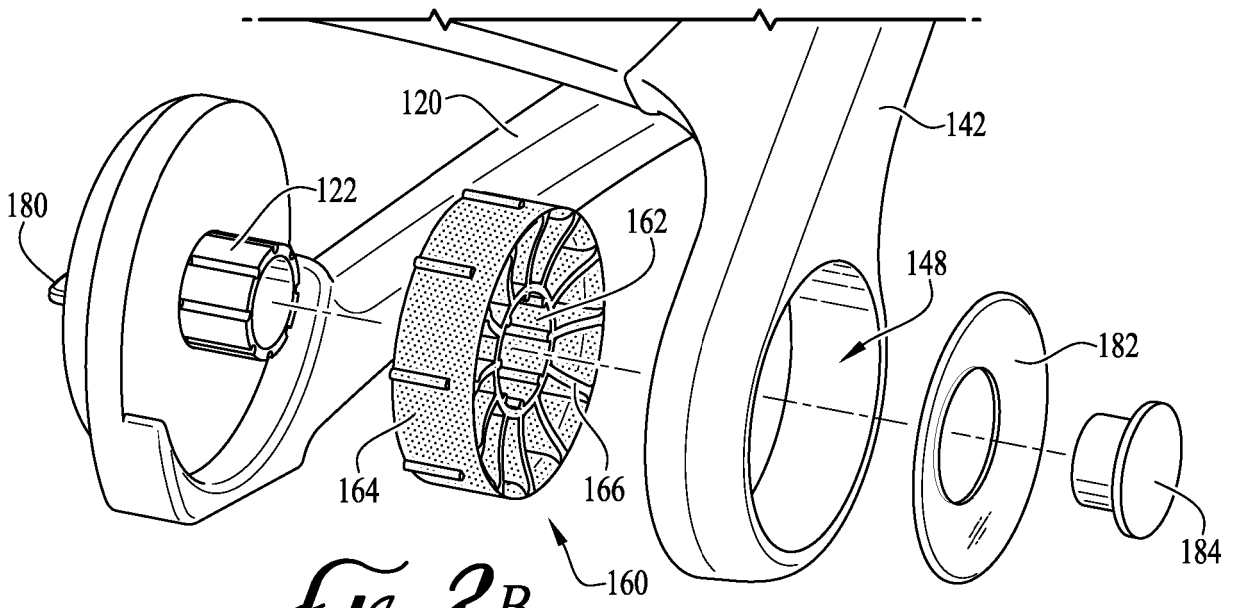
*Fig. 1C*



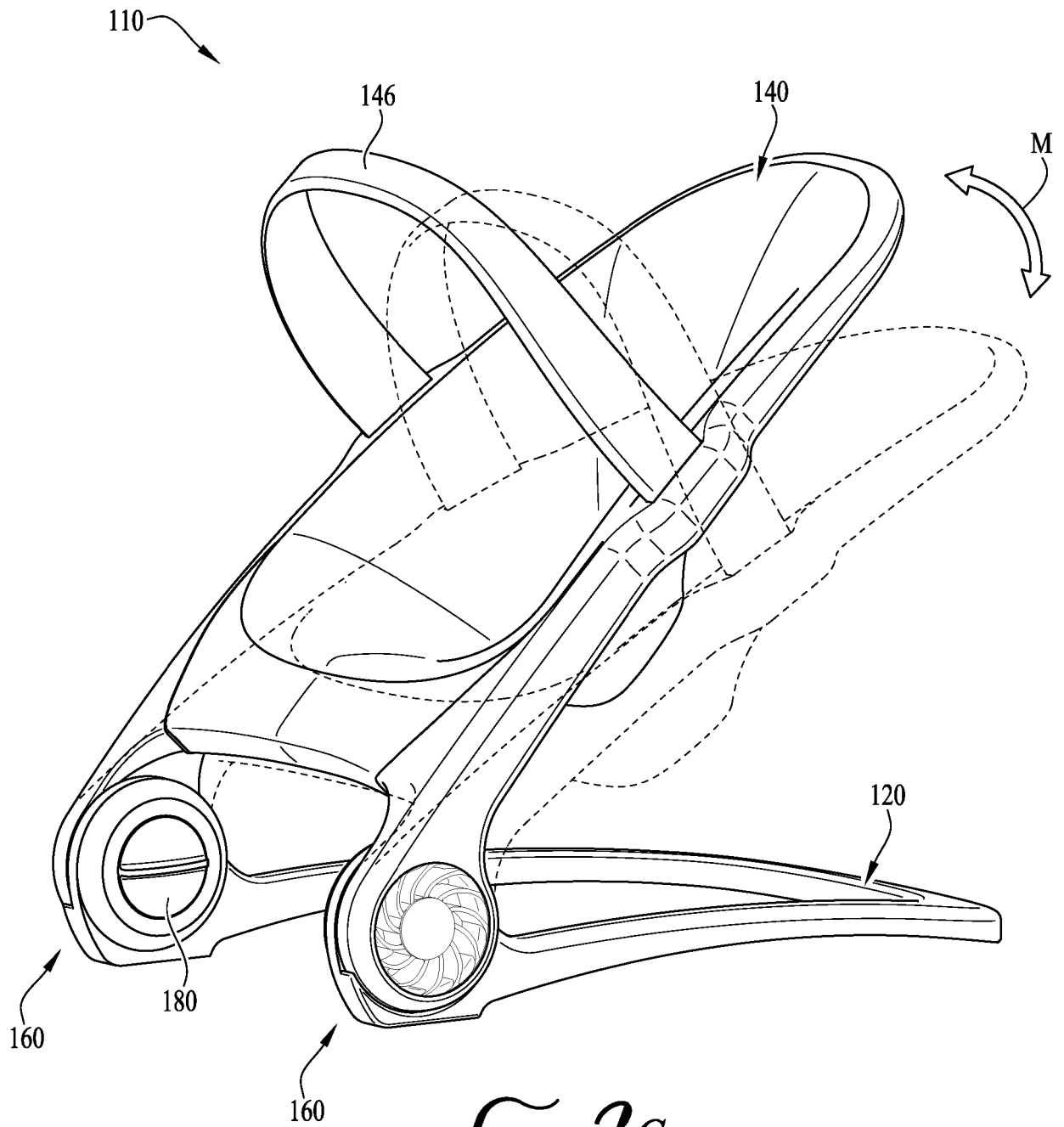
*Fig. 1D*

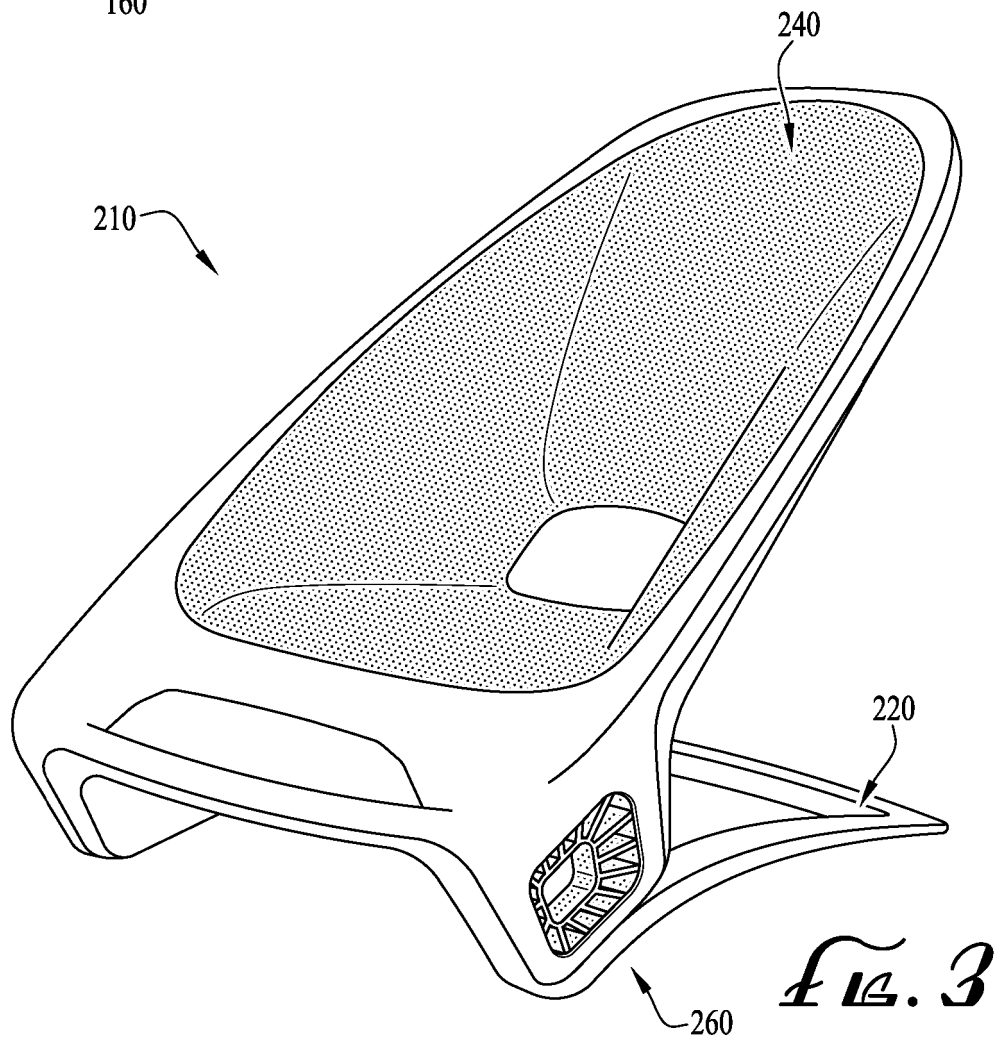
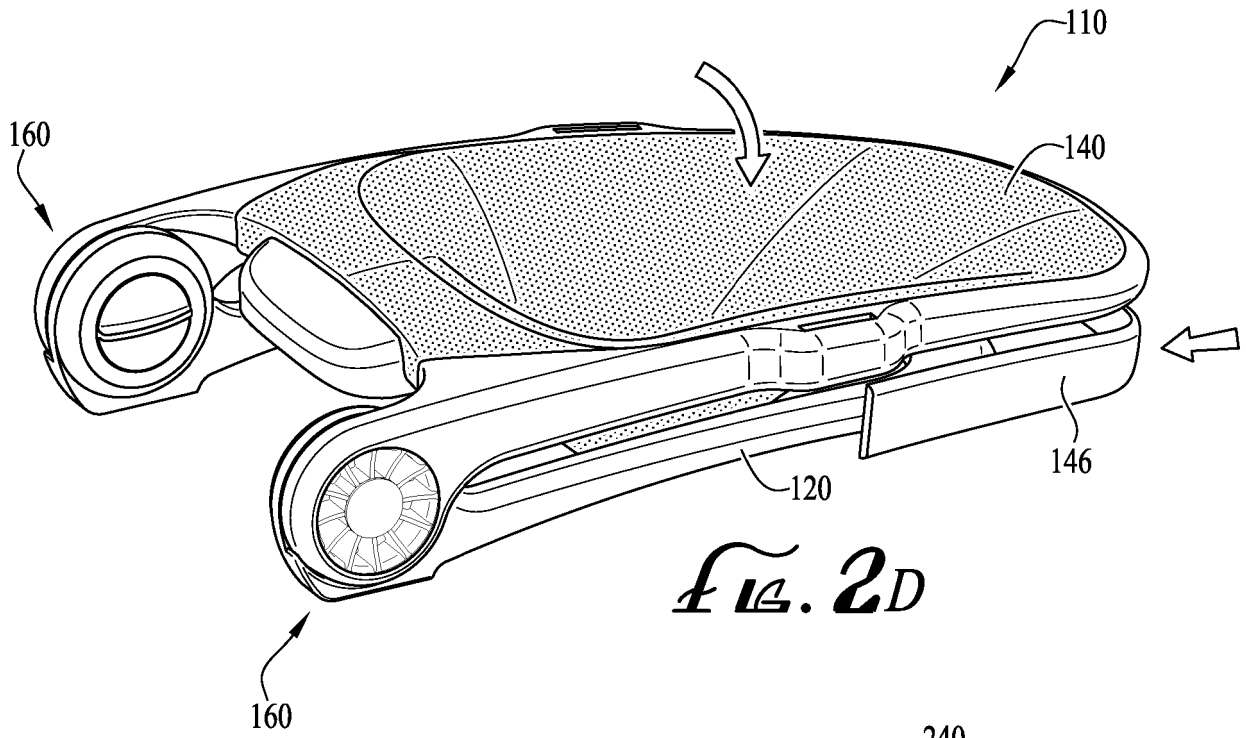


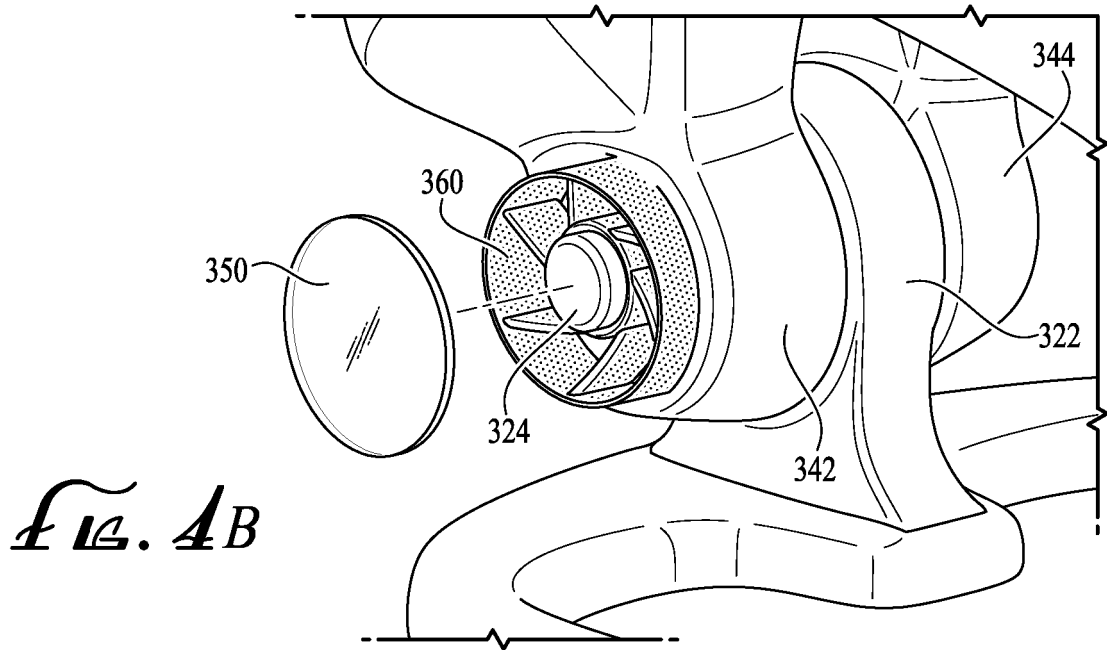
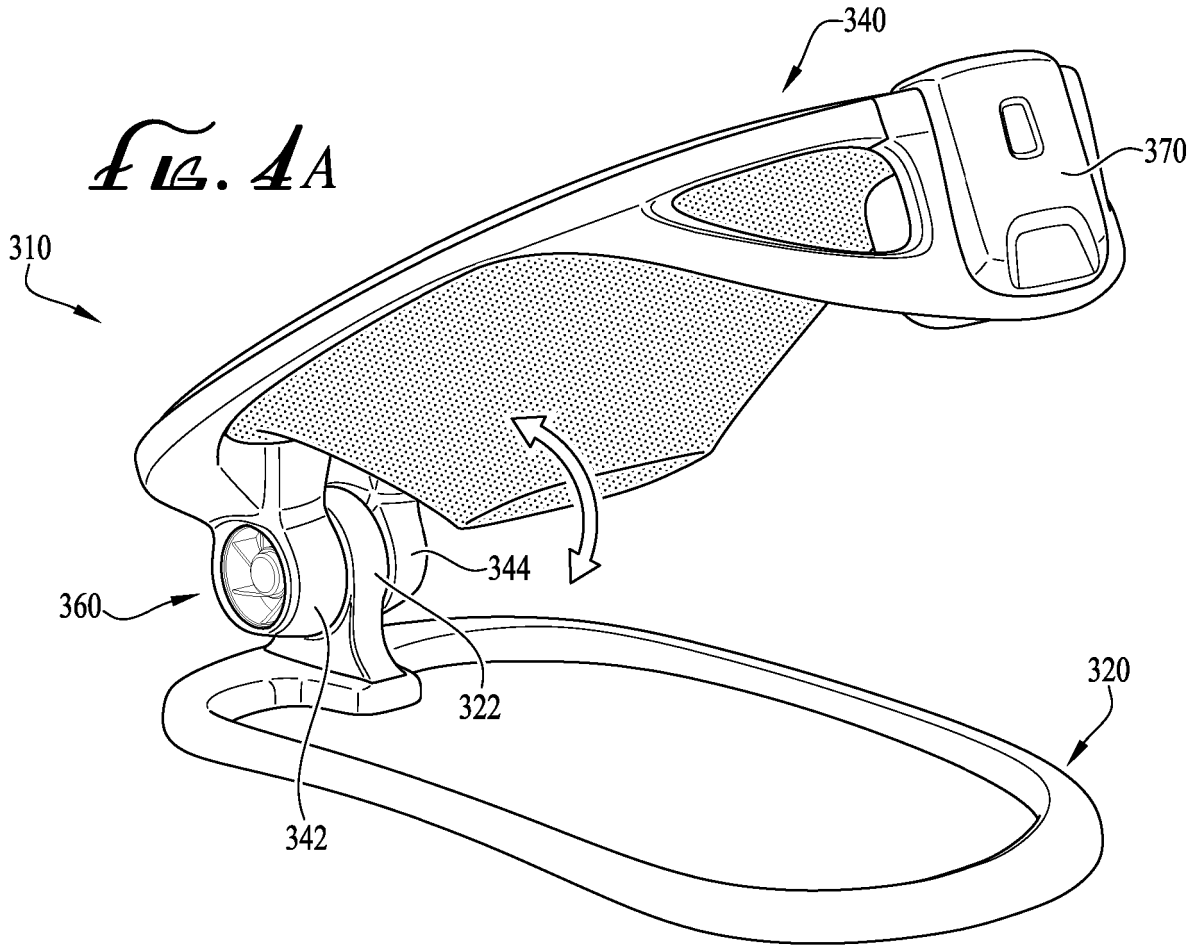
*Fig. 2A*

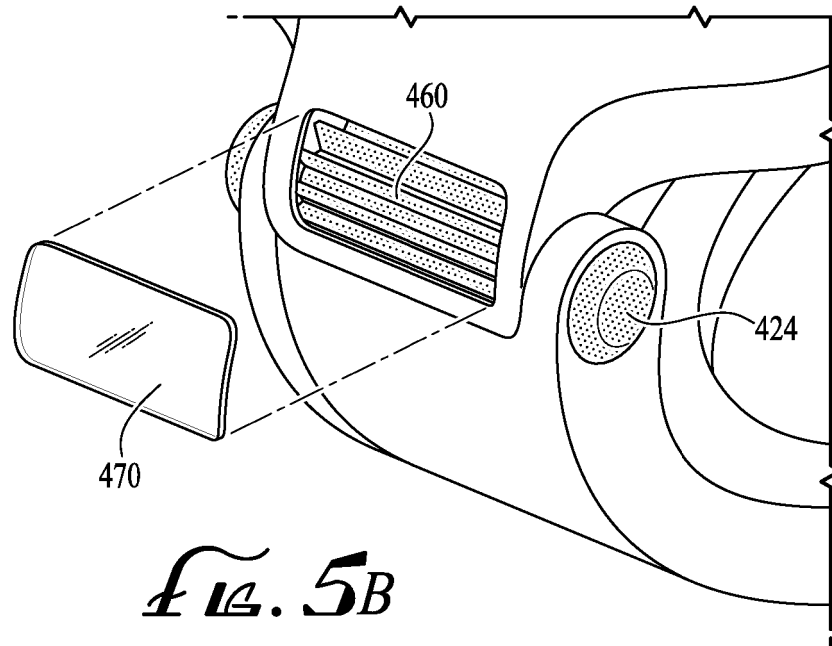
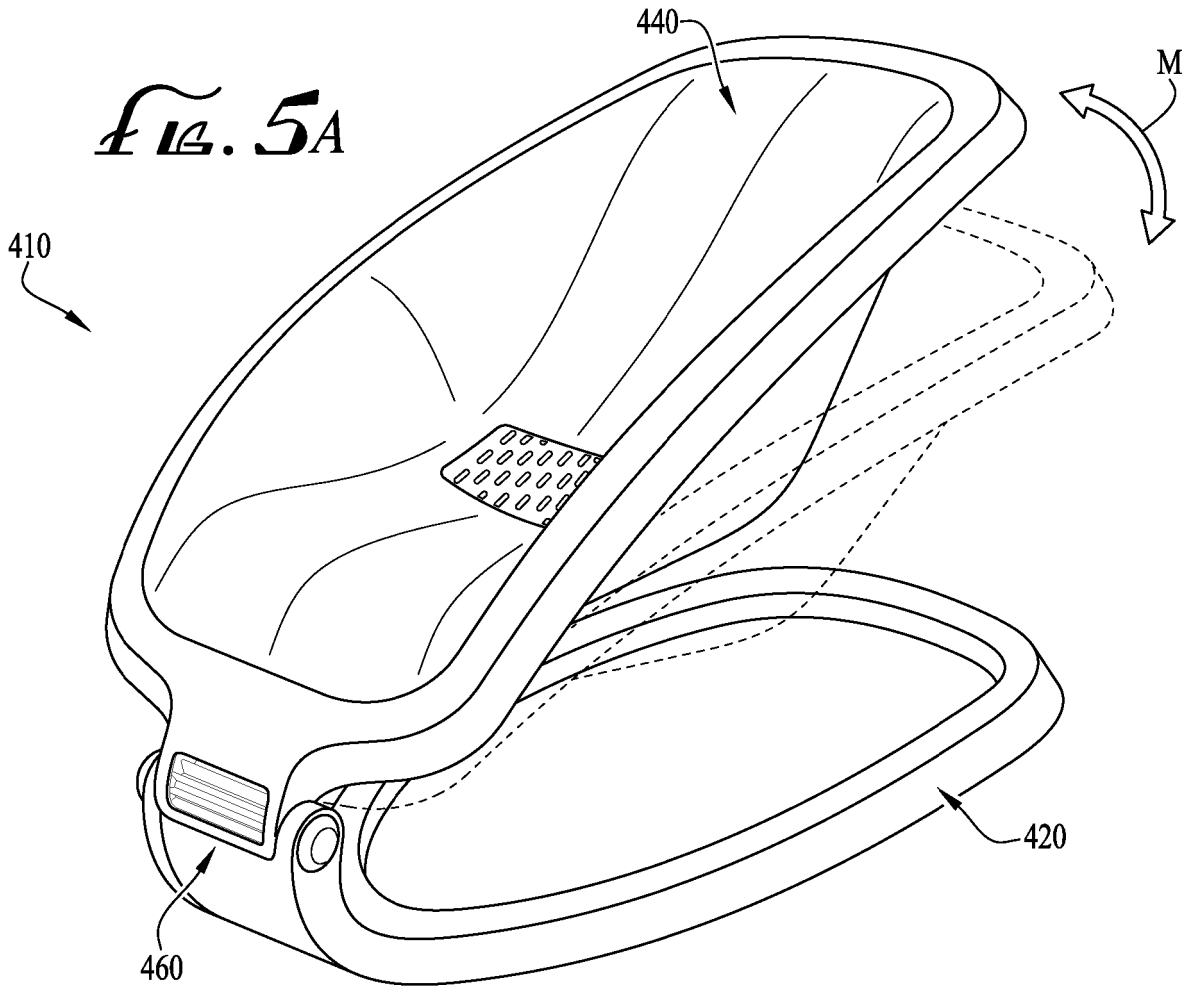


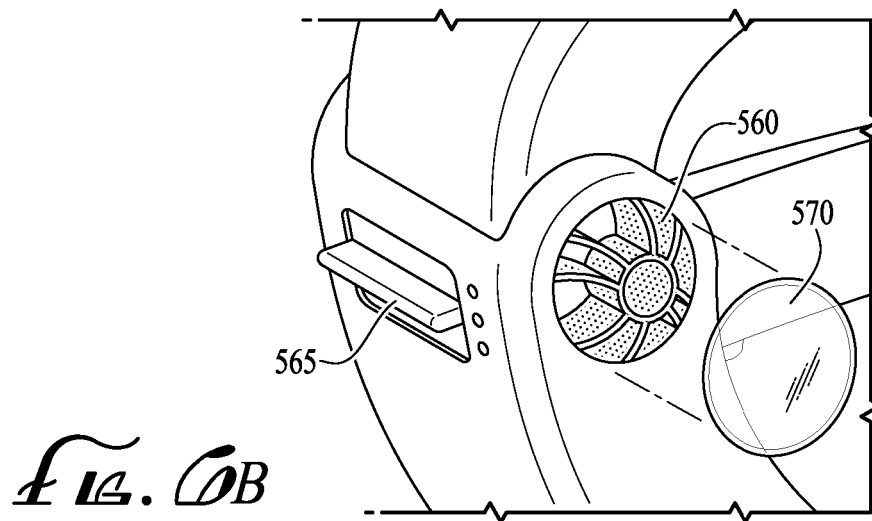
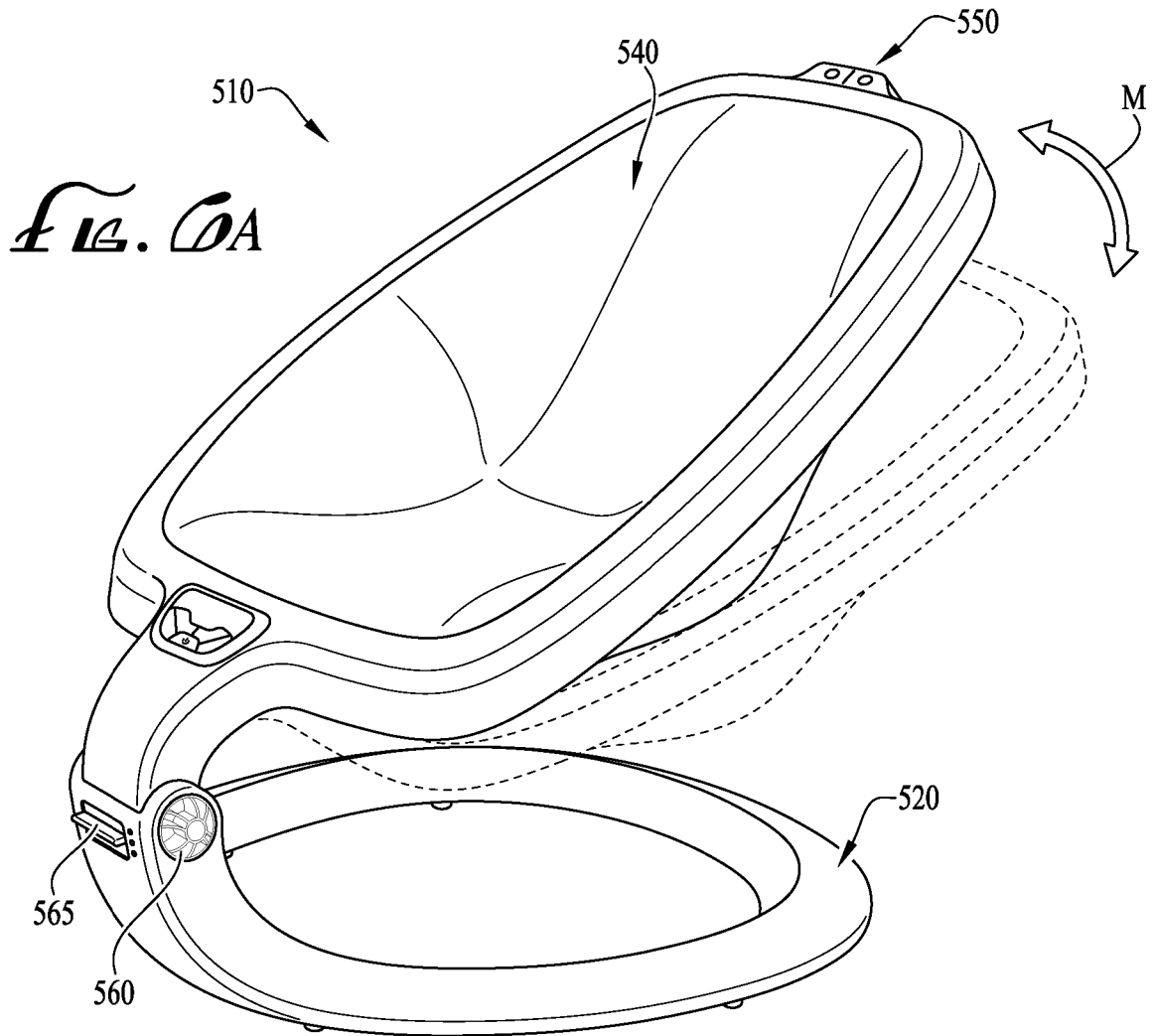
*Fig. 2B*











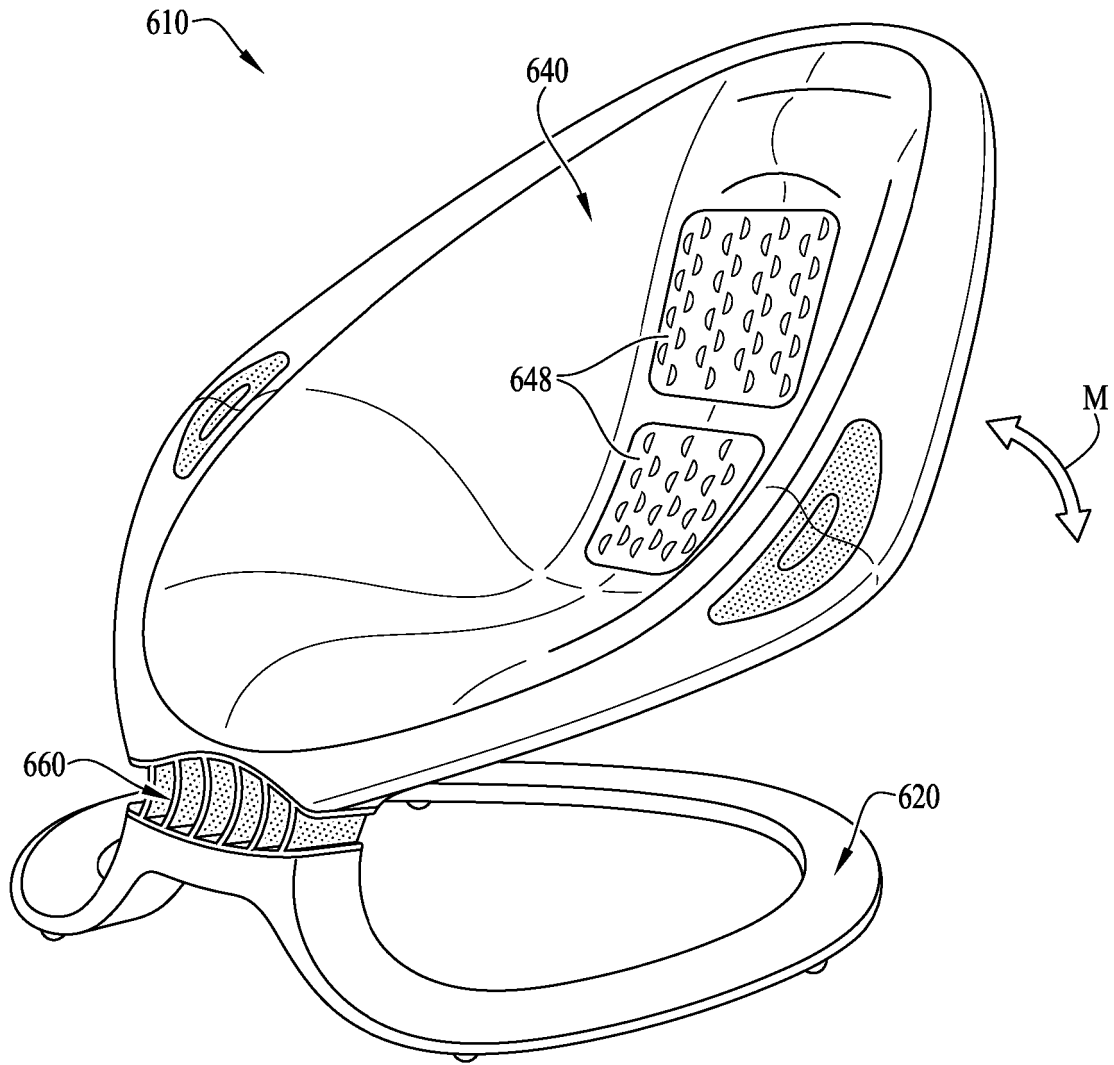
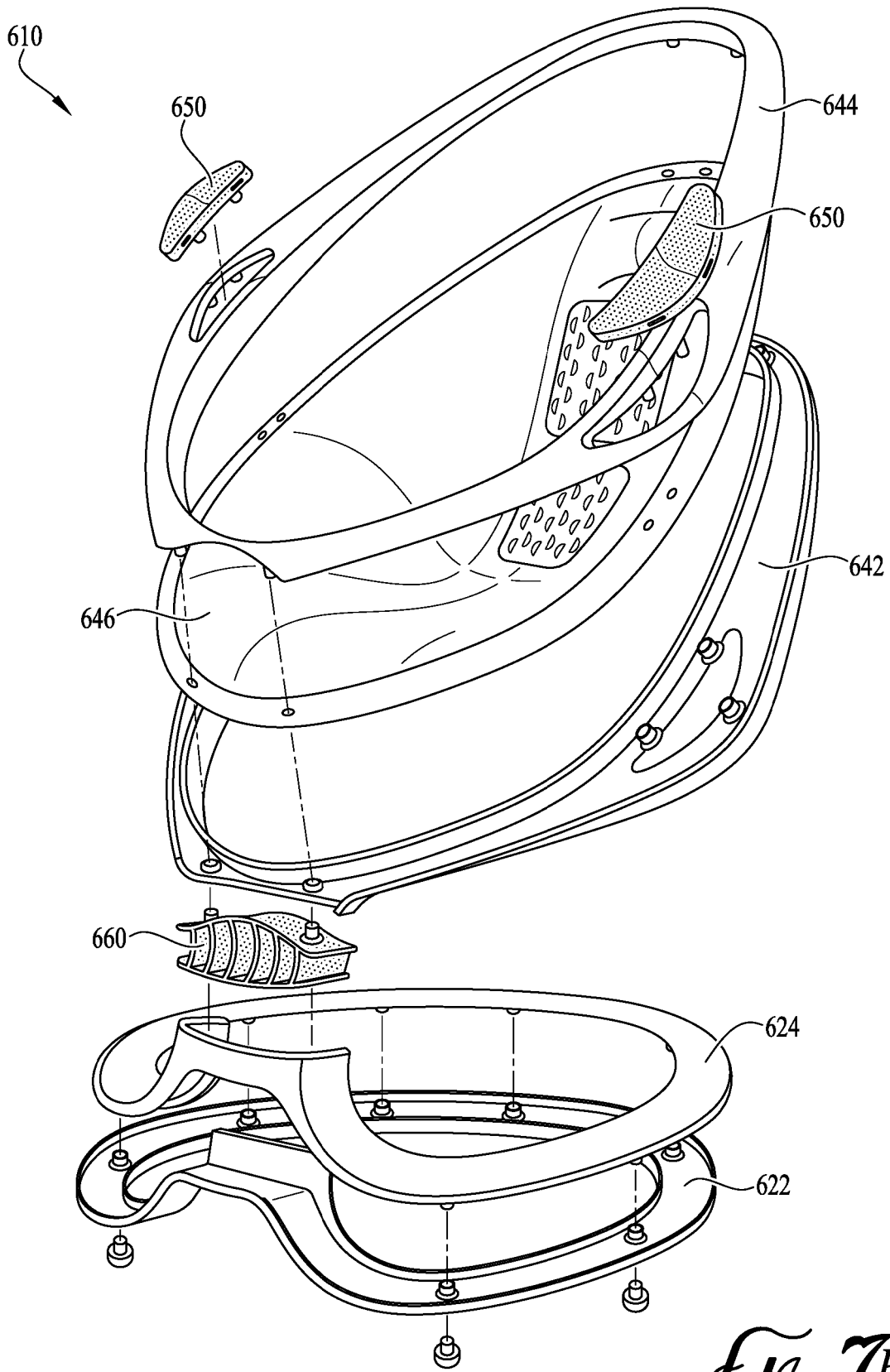
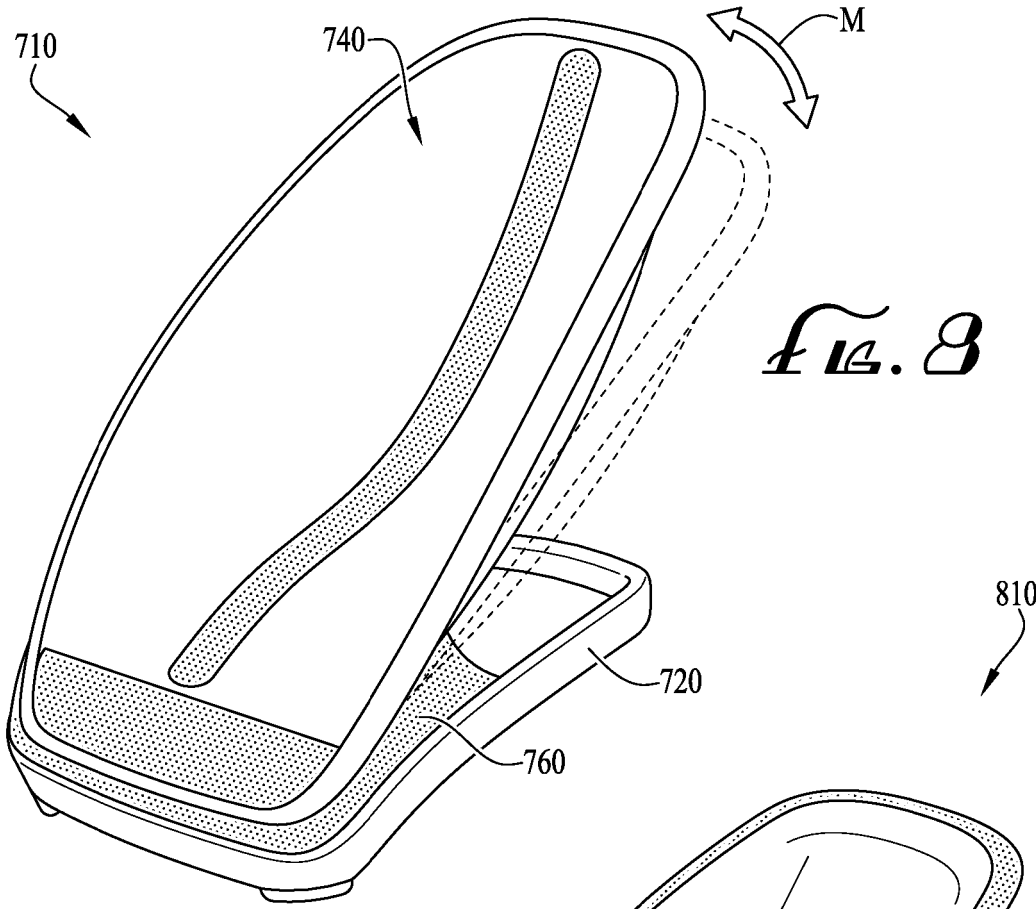


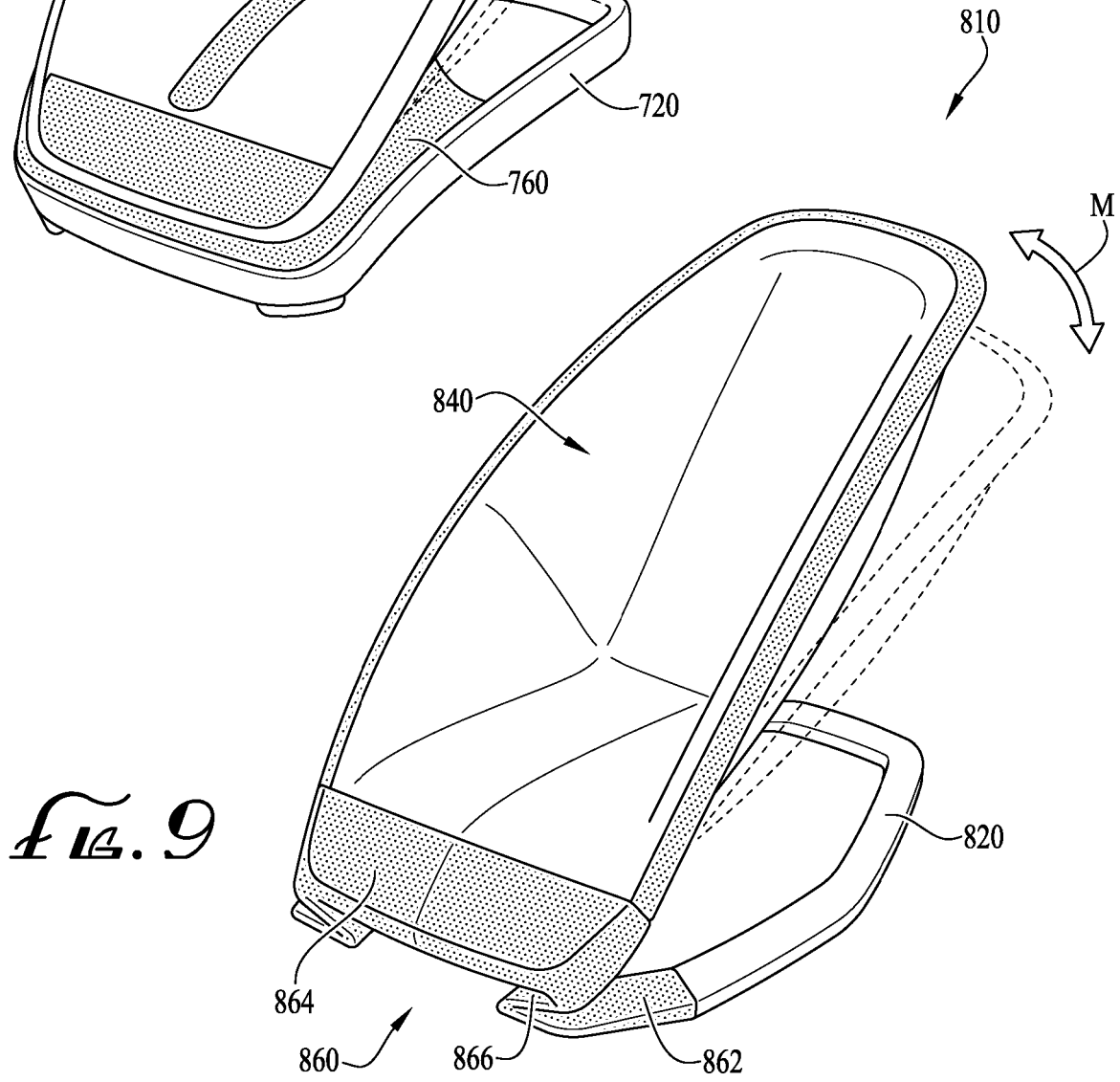
FIG. 7A



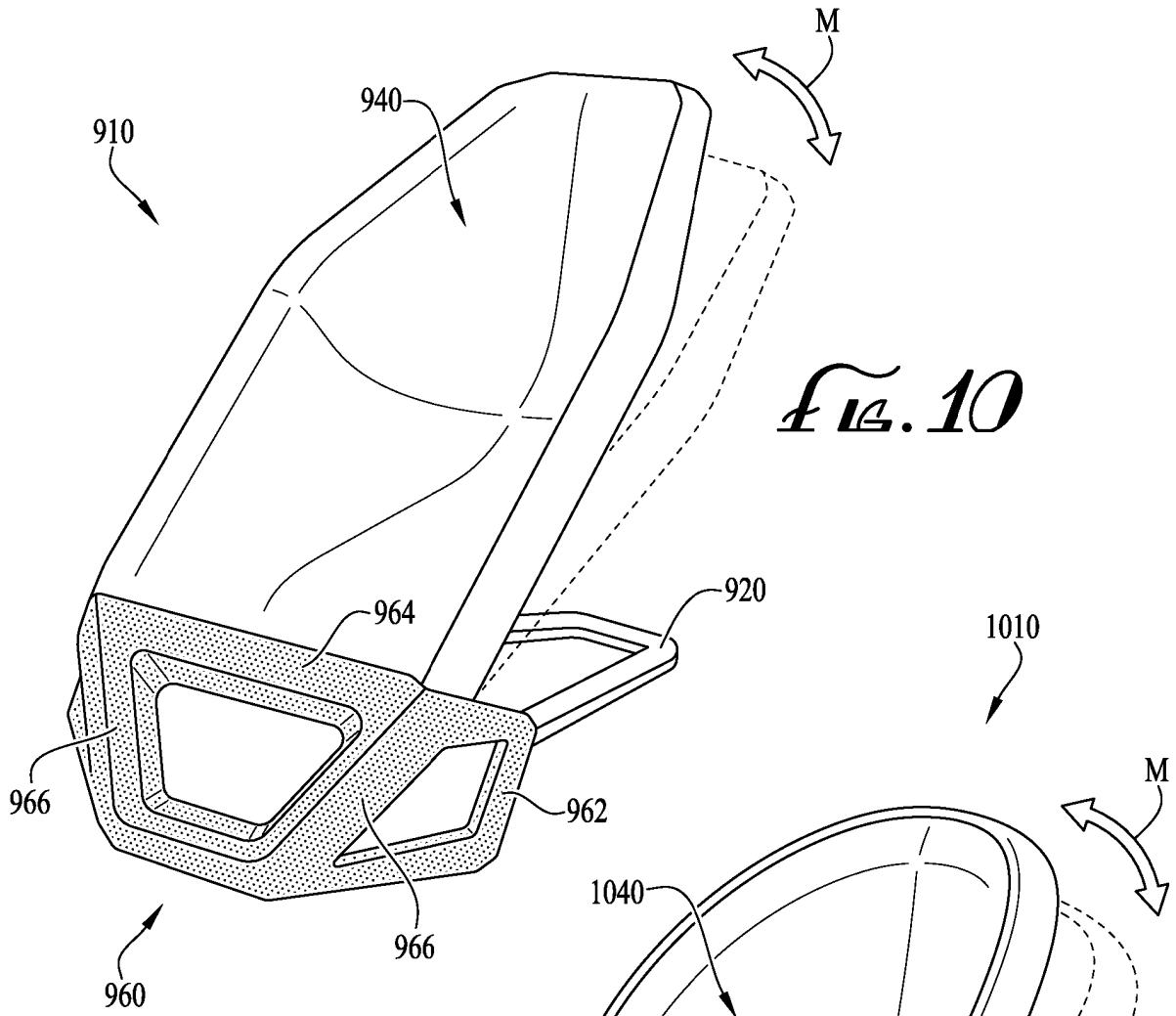
*FIG. 7B*



*Fig. 8*

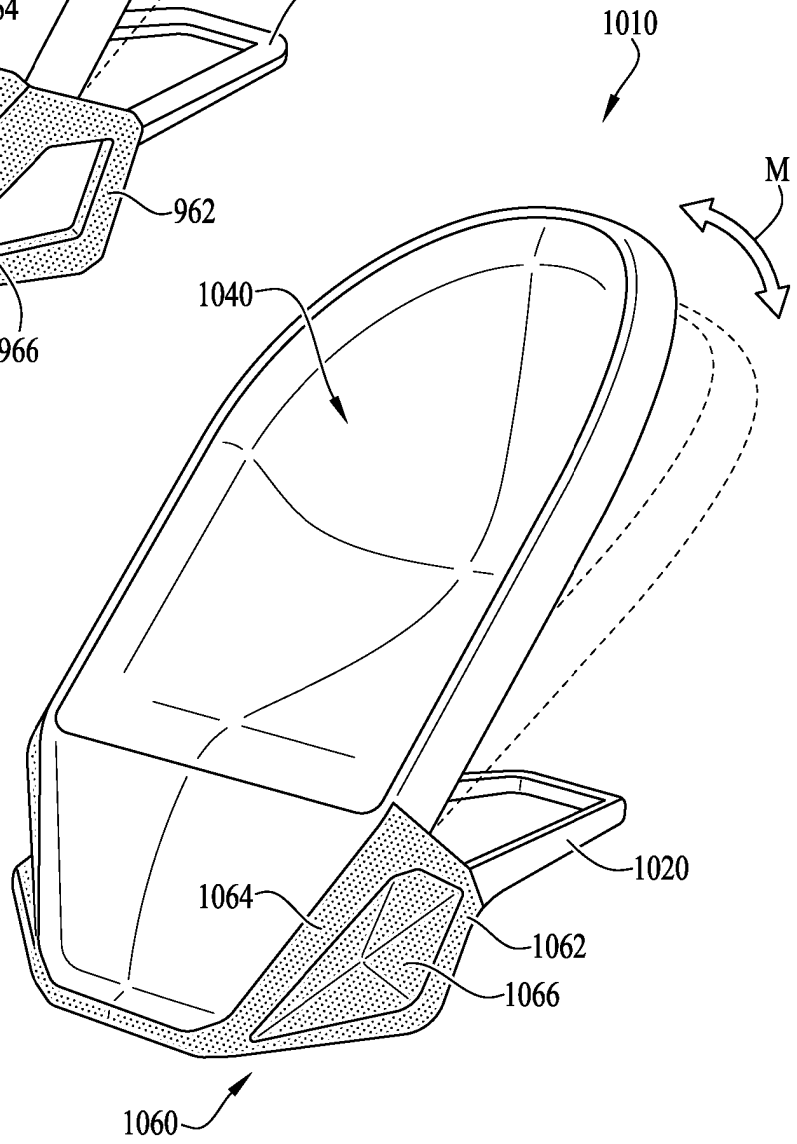


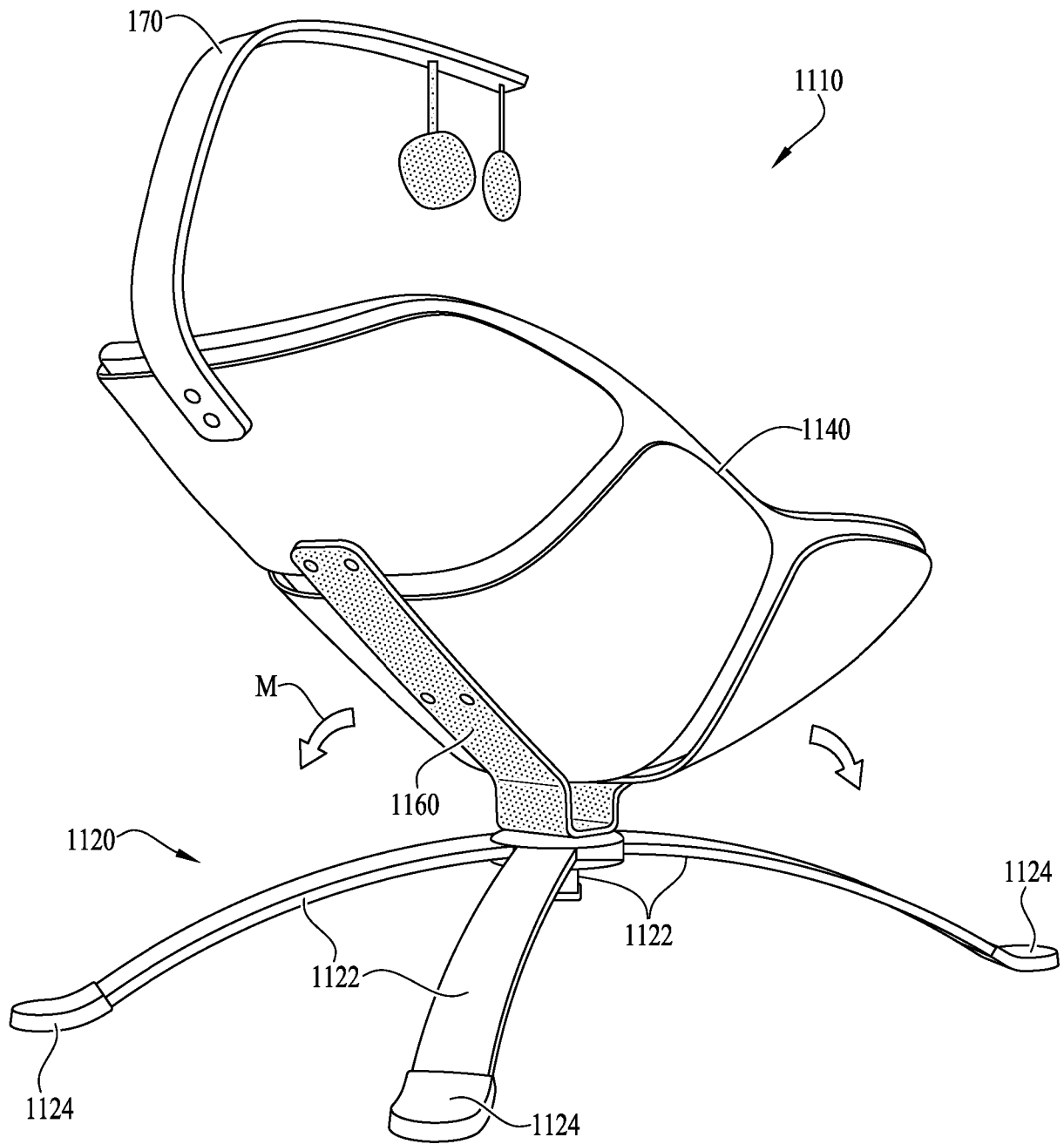
*Fig. 9*



*Fig. 10*

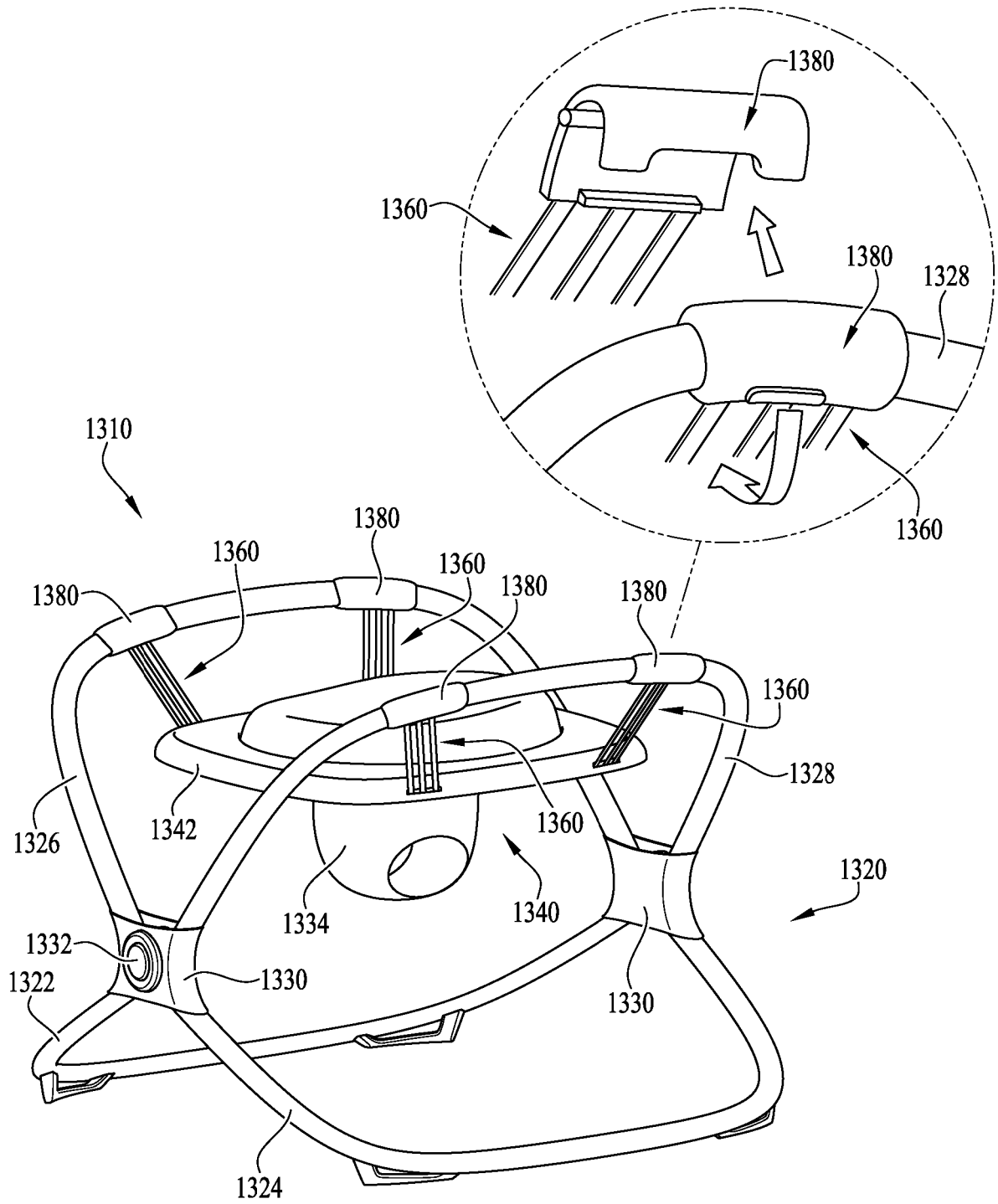
*Fig. 11*



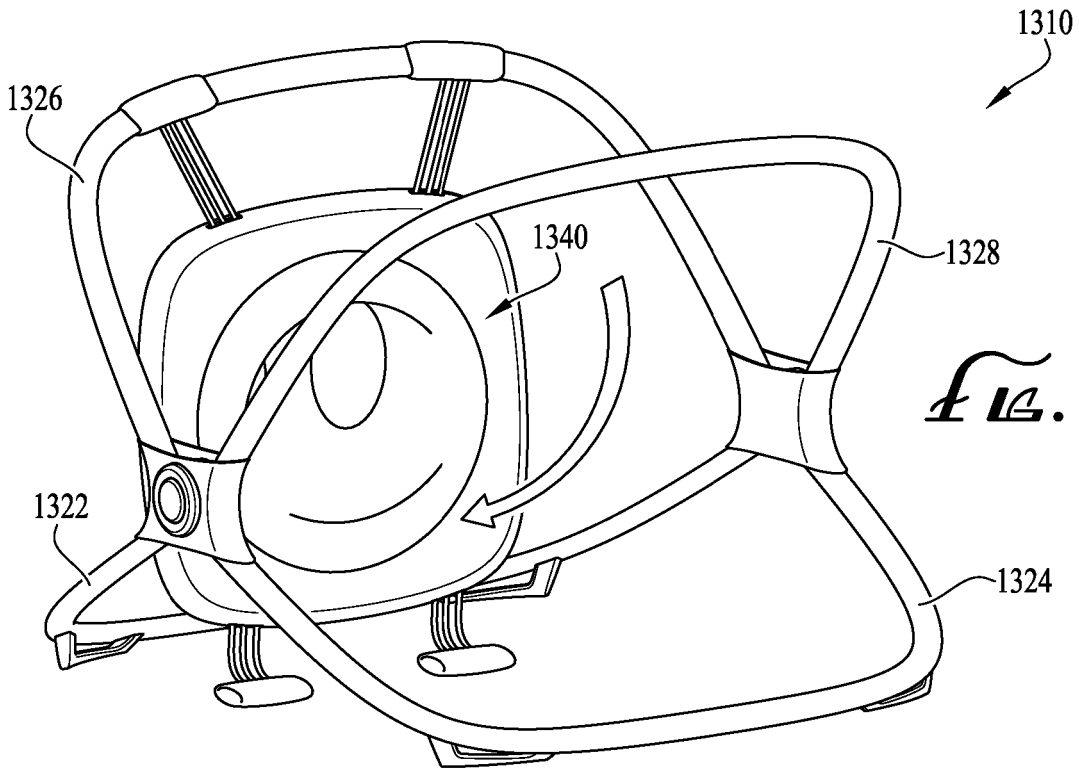


*Fig. 12*

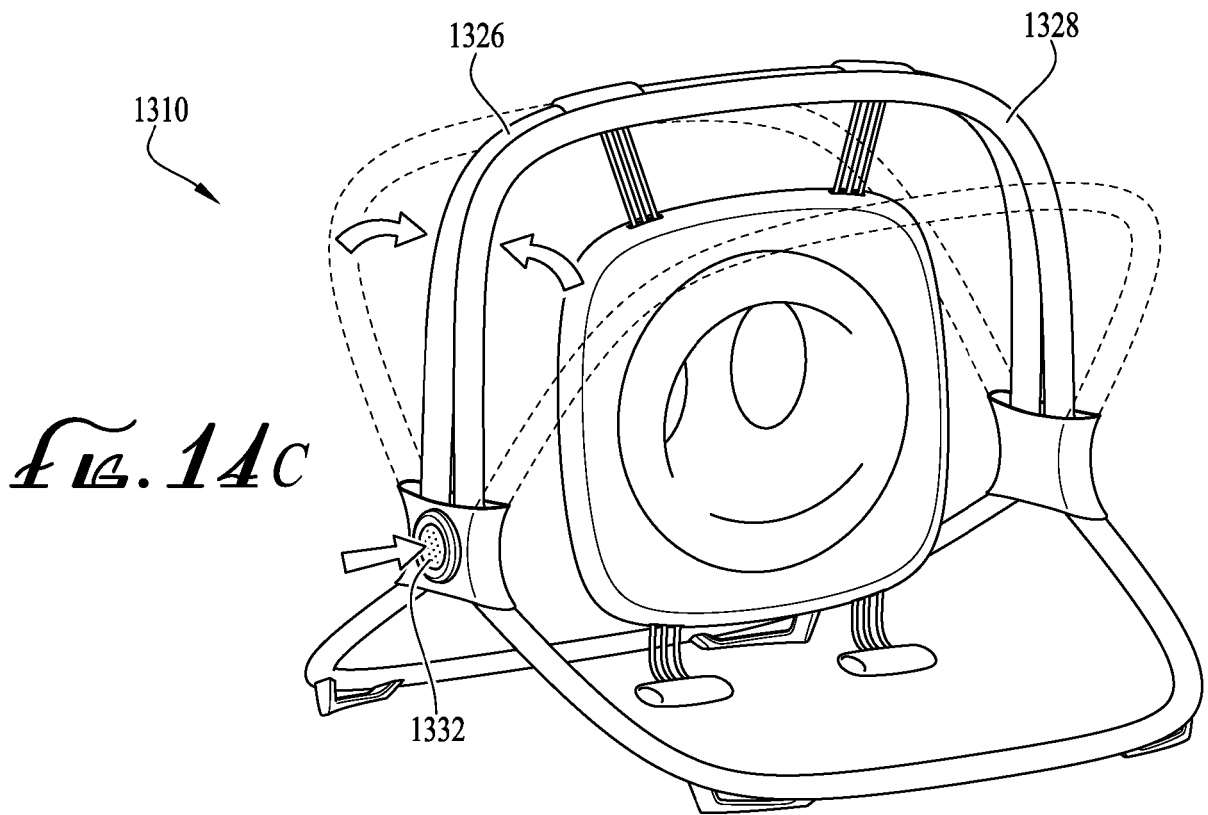




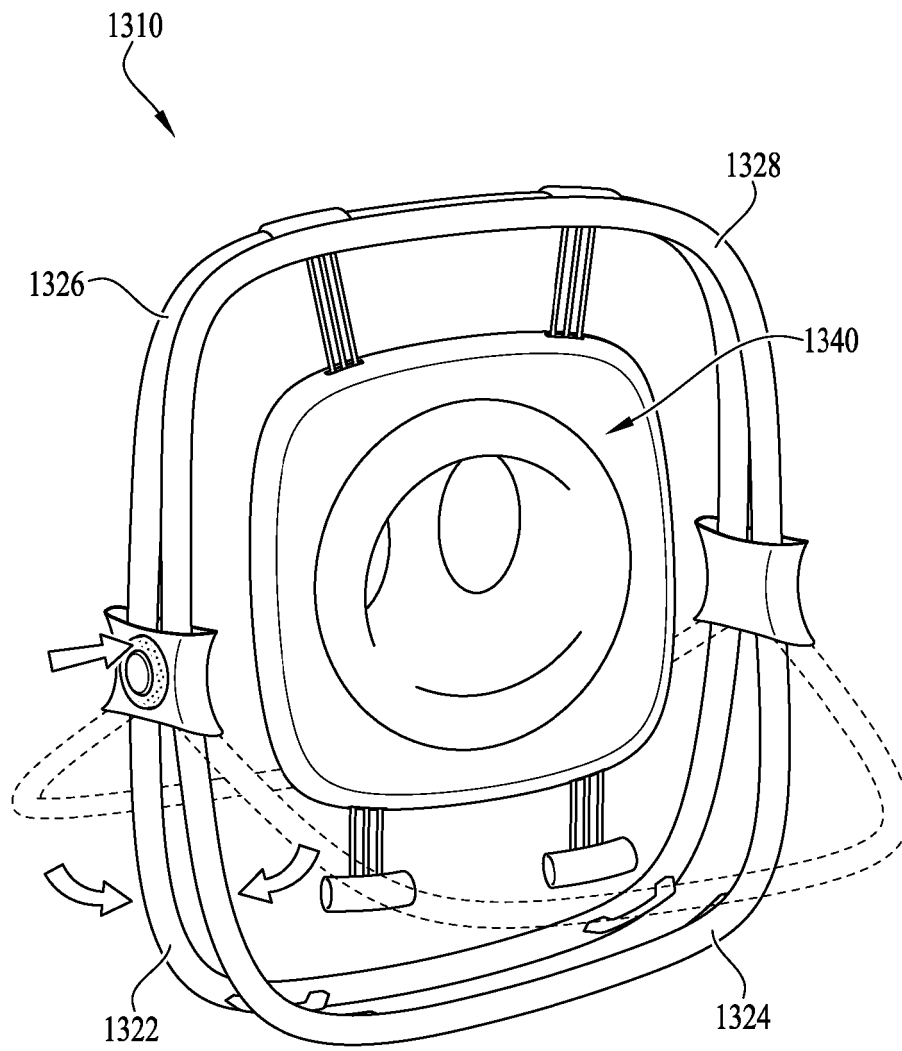
*Fig. 14A*



*Fig. 14B*



*Fig. 14C*



*FIG. 14D*

**REFERENCES CITED IN THE DESCRIPTION**

*This list of references cited by the applicant is for the reader's convenience only. It does not form part of the European patent document. Even though great care has been taken in compiling the references, errors or omissions cannot be excluded and the EPO disclaims all liability in this regard.*

**Patent documents cited in the description**

- US 62395158 [0001]
- US 2007090672 A1 [0003]
- DE 8108262 U1 [0003]
- US 3204953 A [0003]