

(19)



(11)

EP 3 323 482 B1

(12)

EUROPEAN PATENT SPECIFICATION

(45) Date of publication and mention of the grant of the patent:
07.08.2019 Bulletin 2019/32

(51) Int Cl.:
A63H 33/00 (2006.01) E04H 15/48 (2006.01)

(21) Application number: **17188913.2**

(22) Date of filing: **31.08.2017**

(54) **CHILDEN'S PLAY GYMS**

KINDERSPIELDECKEN

JEU DE GYMNASTIQUE POUR ENFANTS

(84) Designated Contracting States:
AL AT BE BG CH CY CZ DE DK EE ES FI FR GB GR HR HU IE IS IT LI LT LU LV MC MK MT NL NO PL PT RO RS SE SI SK SM TR

(30) Priority: **15.09.2016 US 201662394817 P**

(43) Date of publication of application:
23.05.2018 Bulletin 2018/21

(73) Proprietor: **Kids II, Inc.**
Atlanta, GA 30305-1712 (US)

(72) Inventors:
• **REESE, Bradford**
Decatur, GA 30030 (US)

• **ELSON, Brittany**
Atlanta, GA 30305 (US)

(74) Representative: **Haseltine Lake Kempner LLP**
Redcliff Quay
120 Redcliff Street
Bristol BS1 6HU (GB)

(56) References cited:
US-A1- 2003 209 506 US-A1- 2005 181 701
US-A1- 2007 066 446 US-A1- 2007 204 405
US-A1- 2013 280 984

EP 3 323 482 B1

Note: Within nine months of the publication of the mention of the grant of the European patent in the European Patent Bulletin, any person may give notice to the European Patent Office of opposition to that patent, in accordance with the Implementing Regulations. Notice of opposition shall not be deemed to have been filed until the opposition fee has been paid. (Art. 99(1) European Patent Convention).

Description**Brief Description of the Drawings****Cross-Reference to Related Application****[0008]**

[0001] This application claims the benefit of U.S. Provisional Patent Application Serial No. 62/394,817 filed September 15, 2016.

5 Figure 1 is a perspective view of a children's play gym and ancillary toy components, with the toy components detached from the toy bars, according to an example embodiment of the present invention.

Technical Field

[0002] The present invention relates generally to the field of children's accessories, and more particularly to a play gym having a plurality of toy bars.

10 Figure 2 is another perspective view of the children's play gym and ancillary toy components of Figure 1, with the toy components attached.

Background

[0003] Children's play mats or play gyms are used to provide a designated space for infants and other small children to play. Play gyms may be used independently, or in some instances may be used in connection with children's play yards, entertainers, or other types of child containment or child entertainment devices. Previously known play gyms are not foldable or are difficult to fold into a compact space for packaging and storage.

15 Figure 3A is a perspective view of the support bar assembly of the children's play gym of Figure 1, in a first use position.

[0004] Document US-A1-2007/0066446 discloses a children's play gym comprising: a support bar assembly comprising a plurality of toy bars, a first end configured to rest on a support surface and a second end configured to be supported above the support surface; wherein in a use position the support bar assembly is self supporting with the first ends of the plurality of toy bars spaced apart from one another; and at least one toy component configured to releasably attach to at least one toy bar.

20 Figure 3B is a detailed view of the pivot hub portion of the support bar assembly of Figure 3A.

Figure 4 is a perspective view of the support bar assembly of Figure 3A in a second use position.

[0005] Continuing developments and improvements are sought in the field of children's accessories. It is to the provision of a children's play gym or play mat meeting these and other needs that the present invention is primarily directed.

25 Figure 5 is a perspective view of the support bar assembly of Figure 3A in a storage position.

Figures 6A-C show cross-sectional views of the hub of the support bar assembly of Figure 3A, according to an example embodiment of the invention.

Summary

[0006] The present invention is directed to a children's play gym according to claim 1. Subsidiary aspects of the invention are provided in the dependent claims.

30 Figure 7 is a detailed view of the coupling between a play mat and the toy bar of the children's play gym of Figure 1, according to an example embodiment of the invention.

Figure 8 is a detailed view of the coupling between the play mat and the toy bar of Figure 7.

[0007] These and other aspects, features and advantages of the invention will be understood with reference to the drawing figures and detailed description herein, and will be realized by means of the various elements and combinations particularly pointed out in the appended claims. It is to be understood that both the foregoing general description and the following brief description of the drawings and detailed description of example embodiments are explanatory of example embodiments of the invention, and are not restrictive of the invention, as claimed.

35 Figure 9 is a detailed view of the coupling between the play mat and the toy bar of Figure 7.

40 Figures 9A-C are detailed views of an attachment portion of an ancillary toy component of the children's play gym of Figure 1, shown in an uncoupled configuration, according to an example embodiment of the invention.

Figure 10 is a detailed view of the attachment portion of the ancillary toy component of Figure 9 in a coupled configuration.

45 Figures 11A-B are detailed views showing attachment of an ancillary toy component to the toy bar of the children's play gym of Figure 1, according to an example embodiment of the invention.

50 Figure 12 is a detailed view of an ancillary toy component and toy bars of Figure 11, with the toy bars in a folded position.

55 Figure 13 is a perspective view of an ancillary toy

component according to an example embodiment of the invention.

Figure 14 is a detailed view of a toy bar with the ancillary toy component of Figure 13 attached there-
to.

Detailed Description of Example Embodiments

[0009] The present invention may be understood more readily by reference to the following detailed description of example embodiments taken in connection with the accompanying drawing figures, which form a part of this disclosure. It is to be understood that this invention is not limited to the specific devices, methods, conditions or parameters described and/or shown herein, and that the terminology used herein is for the purpose of describing particular embodiments by way of example only and is not intended to be limiting of the claimed invention.

[0010] Also, as used in the specification including the appended claims, the singular forms "a," "an," and "the" include the plural, and reference to a particular numerical value includes at least that particular value, unless the context clearly dictates otherwise. Ranges may be expressed herein as from "about" or "approximately" one particular value and/or to "about" or "approximately" another particular value. When such a range is expressed, another embodiment includes from the one particular value and/or to the other particular value. Similarly, when values are expressed as approximations, by use of the antecedent "about," it will be understood that the particular value forms another embodiment.

[0011] With reference now to the drawing figures, wherein like reference numbers represent corresponding parts throughout the several views, Figures 1-12 show a play gym 10 according to an example embodiment of the present invention. The play gym 10 generally comprises a support bar assembly 20, a pad or mat 60, and at least one ancillary toy component 70, as shown in Figure 1. The support bar assembly 20 is formed from a plurality of toy bars 22. The ancillary toy components 70 are configured to releasably attach to the toy bars 22 of support bar assembly 20, as shown in Figure 2. In example embodiments, the play mat 60 is configured to be releasably coupled to the support bar assembly 20.

[0012] The support bar assembly 20 is configured to rest on a support surface, like the floor, such that a portion of the support bar assembly is supported over the support surface. The support bar assembly 20 of the depicted embodiment, shown in detail in Figures 3-6, comprises a plurality of toy bars 22 and a pivot hub 40. The toy bars 22 are formed from a curved bar having a flat top surface 23 and a flat bottom surface 25. In example embodiments, the toy bars 22 have a smoothly and continuously curved radial or arcuate curvature, for example spanning a generally circular segment or sector, for example extending along a curve spanning a quadrant, or about 90° (i.e., about one-fourth of a circle) whereby two of the bars

extended fully away from one another form a semi-circular 180°. In other embodiments, the curve of the toy bar is larger or smaller. The toy bars 22 can have a thickness of between about 0,32 cm and about 1,27 cm (about 1/8 of an inch and about 1/2 of an inch). In preferred embodiments, the toy bars 22 have a thickness of between about 0,64 cm to 0,95 cm (about 1/4 of an inch to 3/8 of an inch). In other embodiments, the toy bars 22 can be thicker or thinner. The toy bars 22 can have a width of between about 1,27 cm and about 10,16 cm (about 1/2 of an inch and about 4 inches). In preferred embodiments, the toy bars 22 have a width of between about 2,54 and about 7,62 cm (about 1 inch and about 3 inches). In other embodiments the toy bars can be thicker or thinner. The width of the toy bars 22 is preferably greater than the thickness to allow the support bar assembly 20 to be self supporting in at least some configurations. In example embodiments, the width of the toy bar 22 is between about three and about seven times greater than the thickness. In preferred embodiments, the width of the toy bar 22 is between about five and six times greater than the thickness. In other embodiments, the ratio of width to thickness of the toy bar 22 is larger or smaller. The proximal end of each toy bar 22 is pivotally coupled to the proximal ends of one or more additional toy bars by the pivot hub 40, and the distal or free ends of each toy bar is configured to rest on a support surface. In the use position or expanded configuration of the support bar assembly 20, the proximal ends of the toy bars 22 are supported at a vertex or peak elevated above the support surface, the distal ends of the toy bars are positioned on the support surface defining a periphery of a play surface area under the support bar assembly, and medial portions of the toy bars arch upwardly from the support surface to the vertex and surround a three-dimensional play space defined under the support bar assembly.

[0013] The support bar assembly 20 is configured to be self-supporting in at least some configurations, such that it can be used independent of the play mat 60. In the depicted embodiment, three toy bars 22 are pivotally coupled to one another by the pivot hub 40, as shown in Figure 3B. The pivot hub 40 is configured to extend through the proximal end of each toy bar 20 such that the connected ends of the toy bars are stacked on top of one another. In an example use position or expanded configuration of the support bar assembly 20, the toy bars 22 are positioned such that the distal ends of toy bars are equal distance apart, as shown in Figure 3A. In this configuration, each toy bar 22 is positioned at a 120° angle relative to the other toy bars 22, defining a generally circular or triangular play area. In other use positions, the toy bars 22 can be positioned in alternative configurations. For example, the toy bars 22 can form a T-shape where two of the toy bars form an arcuate or semi-circular arch, as shown in Figure 4. In the depicted embodiment, the toy bars 22 of the support bar assembly 20 can be used in any position where the proximal ends are supported above the support surface. The support bar as-

sembly 20 can also be folded to a storage configuration, as shown in Figure 5. In the folded configuration, the toy bars 22 have generally matching curvatures, and are folded or pivoted such that the toy bars are aligned and stacked or nested on top of one another. In other words, the widthwise dimension of each toy bar 22 is aligned with the widthwise dimension of the other toy bars. The storage position is convenient for shipping and storage. In example embodiments, the support bar assembly 20 can be moved between a storage position and one use position. In other embodiments, the support bar assembly can be moved between a storage position and a plurality of use positions.

[0014] In alternative embodiments, the support bar assembly 20 comprises a single semi-circular bar, a parabolic arch, or an assembly of linear or curved segments. In other embodiments, the support bar assembly includes two toy bars 22. For example, a first toy bar that is an arcuate or semi-circular bar with two ends each configured to rest on a support surface and a second curved toy bar pivotally attached to the first toy bar. In other embodiments, the support bar assembly 20 includes four or more toy bars 22. The support bar assembly 20 is preferably formed from a substantially rigid or semirigid material to provide self supporting structure. In example embodiments, the toy bars 22 are formed from an organic or natural material, for example a wood material. Examples of suitable wood materials include beach, ash, plywood, and bamboo. The toy bars 22 can be formed from a composite of multiple wood materials or can be formed from wood laminate boards. In example embodiments, the toy bars 22 comprise continuously curved arcuate panels entirely consisting of wood, or consisting essentially of wood, for example formed by steam bending, mold formed laminate or formed plywood, pressure forming, or other fabrication methods. The toy bars 22 can also be formed from a plastic material or a biopolymer. Example biopolymers include rice-based or corn-based plastics. The toy bars 22 can also be formed from a combination of wood and plastic materials, for example a laminate structure having wood veneer exterior layers. In example embodiments at least 80% of the support bar assembly 20 of the play gym 10 is constructed from non-plastic materials, for example natural or organic materials such as wood.

[0015] In example embodiments, the pivot hub 40 includes a locking mechanism 42, shown in Figures 6A-C. The locking mechanism 42 is configured to releasably lock the toy bars 22 in either a use position or a storage position. The locking mechanism 42 includes a depressible button 44, a locking arm 46, and a biasing spring 48. The bottom or base toy bar 24 includes a ring-shaped recess 26 configured to receive the biasing spring 48 and the locking arm 46. The top toy bar 28 includes a circular recess 30 configured to receive the depressible button 44. The depressible button 44 is configured to engage the top of the locking arm 34. The intermediate toy bar 32 includes a stop surface 34 configured to engage the

locking arm 46. A tab 52 of the locking arm 46 is configured to fit in slots 50 in the top toy bar 28 and intermediate toy bar 32. When in a locked position, as shown in Figure 6A, the biasing spring 48 is suspended between the bottom of the recess 26 in the base toy bar 24 and the locking arm 46. The biasing spring 48 holds the locking arm 46 in engagement against the stop surface 34 on the intermediate toy bar 32 and holds the tab 52 of the locking arm in engagement with the slots 50 in the intermediate toy bar 32 and the top toy bar 28. The engagement between the tab 52 and slots 50 prevents the top and intermediate toy bars 28, 32 from pivoting relative to the base toy bar 24. To reposition to toy bars 22, the depressible button 44 is depressed to push the locking arm 46 down against the biasing spring 48, as shown in Figure 6B. When the locking arm 46 is lowered to the point where the tab 52 is removed from the slots 50, the top and intermediate toy bars 28, 32 can be pivoted relative to the base toy bar 24. The top and intermediate toy bars 28, 32 can include a plurality of slots configured to align with one or more use positions and a storage position. When the top and intermediate toy bars 28, 32 are pivoted to a use or storage position, the biasing spring 48 forces the tab 52 of the locking arm 46 through the slots 50 to lock the toy bars 22 in the new position, as shown in Figure 6C. In alternate embodiments, the pivot hub 40 comprises a non-locking indexing mechanism to releasably retain the toy bars in one or more specified positions relative to one another but allow repositioning upon application of a threshold manual force; or a freely repositionable pivotal coupling mechanism.

[0016] In the example embodiment, the play mat 60 defines a circular outer periphery or profile, as shown in Figures 1 and 2. In alternate embodiments, the mat 60 has a tear-drop shaped, square, rectangular, polygonal, or otherwise shaped peripheral profile. The mat 60 is optionally padded and/or textured for comfort and aesthetics, for example formed of a foam or batting-filled fabric enclosure or other soft goods material. Optionally, surface entertainment features corresponding to the theme of an animal or character, or another child-friendly theme, are applied to the mat 60. The surface features can be printed on the mat 60 or can be different material having differing textures attached to the mat with adhesive, stitching, or other attachment means. Optionally, the mat 60 further comprises a collar or upright wall portion. In example embodiments, the mat 60 has a size and shape generally conforming to or corresponding to the outer periphery of the play area defined beneath the support bar assembly 20 in its expanded or use configuration, with the distal ends of the toy bars positioned on the support surface at or around the periphery of the mat at two or more spaced locations. In alternate embodiments, the mat may be smaller or larger than the play area defined beneath the support bar assembly, for example being at least partially included within or extending at least partially beyond the points of contact of the distal ends of the toy bars on the support surface.

[0017] In an example mode of use, the mat 60 is laid out on a floor or other support surface. The mat 60 can be used on its own or in conjunction with the support bar assembly 20. In the depicted embodiment, the mat 60 can be detachably coupled to the support bar assembly 20, as shown in Figure 2. As shown in Figures 7 and 8, the mat 60 includes flexible connectors 62. Each flexible connector 62 is attached to the mat 60 at a first, proximal end. The second, distal end of the flexible connector 62 includes a tab 64. The flexible connectors 62 are attached to the periphery of the mat 60 in a position to align with the distal end of the toy bars 22 of the support bar assembly 20. The distal end of each toy bar 22 includes a slot 36 configured to receive the flexible connector 62. To attach the mat 60 to the support bar assembly 20, the tab 64 is folded parallel with the flexible connector 62 and push fitted through the slot 36 in the toy bar 22. The tab 64 can be folded perpendicular to the flexible connector 62 to prevent the tab from being retracted through the slot, and hold the connector in engagement with the toy bar 22. The mat 60 and connectors 62 can be dimensioned such that attaching the mat to the support bar assembly 20 creates tension in the toy bars to increase stability. The tab 64 is moved to the parallel position to remove the flexible connector 62 from the slot 36 in the toy bar 22. In other embodiments, the mat 60 can include loops, snaps, ties, hook-and-loop fasteners, buckles, fasteners, sockets, or other removable attachment means for releasably attaching the mat to the support bar assembly 20.

[0018] The one or more ancillary toy component(s) 70 can comprise a toy, rattle, mirror, mobile element, or other device or object configured to entertain a child or infant. The toy components 70 are configured to be suspended or otherwise removably attached to a toy bar 22. In example embodiments, the toy component 70 includes a flexible connector 72 as shown in Figures 9A-C. In example embodiments, the flexible connector 72 comprises a flat strip 74 of fabric, webbing, or other flexible material, with a first, proximal end attached to the toy component 70 and a second, distal end attached to a flat tab 76. In example embodiments, the strip 74 includes a slot 78. In a first mode of attachment, the tab 76 can be folded and push fitted through the slot 78 to create a loop as shown in Figure 10. In this configuration, the toy component 70 can be attached to a hook or clip on the toy bar. In other embodiments, the flexible connector 72 includes other fastening mechanisms, for example a button and button hole, configured to create the loop of Figure 10. In another mode of use, the tab 76 of the flexible connector 72 can be folded and push fitted through the one or more holes 38 in the toy bar 22. The holes 38 extend through the thickness of the toy bar 22. To attach the toy component 70, the tab 76 is folded and inserted through the hole 38 from the bottom surface 25 of the toy bar 22 towards the top surface 23, as shown in Figure 11A. The tab 76 is unfolded to rest against the top surface 23 of the toy bar 22 to hold the toy component 70 above the support sur-

face. In example embodiments, the tab 76 has a thickness smaller than the gap between the stacked toy bars 22 and is configured to sit flush against the top surface 23 of the toy bar. In this mode of use, the toy bars 22 can be folded to a storage position, stacked on top of one another, with the toy component 70 still attached to the toy bar, as shown in Figure 12. In example embodiments, each toy bar 22 includes a plurality of holes 38 allowing the toy components 70 to be attached at a variety of positions and heights relative to the support surface. The toy components 70 can be formed from a fabric material such as wool, cotton, or felt. The flexible connector 72 can be formed from a flexible fabric such as felt. Alternatively, the connector can be formed of plastic or nylon webbing, string, cord, or other natural or synthetic fabrics or other flexible or pliable materials.

[0019] Figures 13 and 14 show a toy component 170 according to another example embodiment of the invention. The toy component 170 includes a resilient or bendable rod 172. In the depicted embodiment, the rod 172 is curved and includes a plurality of rings 178 that a child can move along the rod. Each end of the rod 172 includes a connection hub 174 with a knob 176. Each knob 176 is configured to be inserted into a hole 38 in the toy bar 22, as shown in Figure 14. The rod 172 is bent to move the knobs 176 toward one another to align with holes in the toy bar 22. The rod 172 creates tension to hold the knobs 176 in engagement with the holes 38.

[0020] While the invention has been described with reference to example embodiments, it will be understood by those skilled in the art that a variety of modifications, additions and deletions are within the scope of the invention, as defined by the following claims.

Claims

1. A children's play gym (10) comprising:
 - a support bar assembly (20) comprising a plurality of toy bars (22), each of the plurality of toy bars (22) having substantially matching curvatures, a first end configured to rest on a support surface and a second end configured to be supported above the support surface, the second ends of the plurality of toy bars being pivotally coupled to one another by a hub (40); wherein in a use position the support bar assembly (20) is self supporting with the first ends of the plurality of toy bars (22) spaced apart from one another and wherein in a storage position the widths of the toy bars (22) are aligned and the toy bars (22) are nested on top of one another; and
 - at least one toy component (70, 170) configured to releasably attach to at least one toy bar (22).
2. The children's play gym of claim 1, further comprising

a play mat (60) for resting on a support surface, and defining a play area for receiving a child thereon.

3. The children's play gym of claim 2, wherein the first ends of the toy bars (22) are releasably attached to the outer periphery of the play mat (60).
4. The children's play gym of claim 3, wherein the play mat (60) includes a plurality of attachment devices (62) positioned on the outer periphery of the play mat.
5. The children's play gym of claim 4, wherein the plurality of attachment devices (62) are configured to engage a slot (36) on the first end of each toy bar (22).
6. The children's play gym of any preceding claim, wherein the hub (40) includes a locking mechanism (42) configured to releasably hold the toy bars (22) in a storage position and at least one use position.
7. The children's play gym of any preceding claim, wherein each of the plurality of toy bars (22) has a smoothly and continuously curved radial curvature spanning about one-fourth of a circle.
8. The children's play gym of any preceding claim, wherein the toy bars (22) comprise continuously curved arcuate panels of wood.

Patentansprüche

1. Kinderspielgerät (10), aufweisend:

eine Stützstangenbaugruppe (20), welche eine Vielzahl von Spielzeugstangen (22) aufweist, wobei jede der Vielzahl von Spielzeugstangen (22) im Wesentlichen übereinstimmende Krümmungen aufweist, wobei ein erstes Ende dafür ausgelegt ist, um auf einer Auflagefläche zu ruhen, und ein zweites Ende dafür ausgelegt ist, um über der Auflagefläche gehalten zu werden, wobei die zweiten Enden der Vielzahl von Spielzeugstangen durch eine Nabe (40) schwenkbar miteinander gekoppelt sind; wobei die Stützstangenbaugruppe (20) in einer Gebrauchsstellung selbst tragend ist, während die ersten Enden der Vielzahl von Spielzeugstangen (22) voneinander beabstandet sind, und wobei in einer Aufbewahrungsstellung die Breiten der Spielzeugstangen (22) ausgerichtet sind und die Spielzeugstangen (22) über einander geschachtelt sind; und mindestens eine Spielzeugkomponente (70,170), welche dafür ausgelegt ist, um lösbar mit mindestens einer Spielzeugstange (22) verbunden zu sein.

2. Kinderspielgerät nach Anspruch 1, ferner aufweisend eine Spielmatte (60), um auf einer Auflagefläche zu ruhen und eine Spielfläche zu definieren, um ein Kind darauf aufzunehmen.

3. Kinderspielgerät nach Anspruch 2, wobei die ersten Enden der Spielzeugstangen (22) an dem Außenumfang der Spielmatte (60) lösbar befestigt sind.

4. Kinderspielgerät nach Anspruch 3, wobei die Spielmatte (60) eine Vielzahl von Befestigungsvorrichtungen (62) umfasst, welche auf dem Außenumfang der Spielmatte positioniert sind.

5. Kinderspielgerät nach Anspruch 4, wobei die Vielzahl von Befestigungsvorrichtungen (62) dafür ausgelegt ist, um mit einem Schlitz (36) an dem ersten Ende von jeder Spielzeugstange (22) in Eingriff zu gelangen.

6. Kinderspielgerät nach einem der vorhergehenden Ansprüche, wobei die Nabe (40) einen Verriegelungsmechanismus (42) umfasst, welcher dafür ausgelegt ist, um die Spielzeugstangen (22) in einer Aufbewahrungsstellung und mindestens einer Gebrauchsstellung lösbar zu halten.

7. Kinderspielgerät nach einem der vorhergehenden Ansprüche, wobei jede der Vielzahl von Spielzeugstangen (22) eine gleichmäßig und kontinuierlich gekrümmte, radiale Krümmung aufweist, welche sich über ein Viertel eines Kreises erstreckt.

8. Kinderspielgerät nach einem der vorhergehenden Ansprüche, wobei die Spielzeugstangen (22) kontinuierlich gekrümmte, bogenförmige Platten aus Holz aufweisen.

Revendications

1. Jeu de gymnastique pour enfants (10), comprenant :

un ensemble barre de support (20) comprenant une pluralité de barres de jouet (22), chacune de la pluralité de barres de jouet (22) ayant des courbures sensiblement correspondantes, une première extrémité conçue pour reposer sur une surface de support et une seconde extrémité conçue pour être supportée au-dessus de la surface de support, les secondes extrémités de la pluralité de barres de jouet étant accouplées de manière pivotante les unes aux autres par un moyeu (40) ; dans une position d'utilisation, l'ensemble barre de support (20) étant autoportant avec les premières extrémités de la pluralité de barres de jouet (22) espacées les unes des autres et dans une position de rangement, les

- largeurs des barres de jouet (22) étant alignées et les barres de jouet (22) étant emboîtées les unes sur les autres ; et au moins un élément de jouet (70, 170) conçu pour être fixé de manière amovible à au moins une barre de jouet (22). 5
2. Jeu de gymnastique pour enfants selon la revendication 1, comprenant en outre un tapis de jeu (60) destiné à reposer sur une surface de support, et définissant une aire de jeu pour y recevoir un enfant. 10
3. Jeu de gymnastique pour enfants selon la revendication 2, les premières extrémités des barres de jouet (22) étant fixées de manière amovible à la périphérie extérieure du tapis de jeu (60). 15
4. Jeu de gymnastique pour enfants selon la revendication 3, le tapis de jeu (60) comprenant une pluralité de dispositifs de fixation (62) positionnés sur la périphérie extérieure du tapis de jeu. 20
5. Jeu de gymnastique pour enfants selon la revendication 4, la pluralité de dispositifs de fixation (62) étant conçus pour venir en prise avec une fente (36) sur la première extrémité de chaque barre de jouet (22). 25
6. Jeu de gymnastique pour enfants selon l'une quelconque des revendications précédentes, le moyeu (40) comprenant un mécanisme de verrouillage (42) conçu pour maintenir de manière amovible les barres de jouet (22) dans une position de rangement et au moins une position d'utilisation. 30
35
7. Jeu de gymnastique pour enfants selon l'une quelconque des revendications précédentes, chacune de la pluralité de barres de jouet (22) ayant une courbure radiale incurvée de manière régulière et continue qui s'étend sur environ un quart de cercle. 40
8. Jeu de gymnastique pour enfants selon l'une quelconque des revendications précédentes, les barres de jouet (22) comprenant des panneaux de bois arqués incurvés de manière continue. 45

50

55

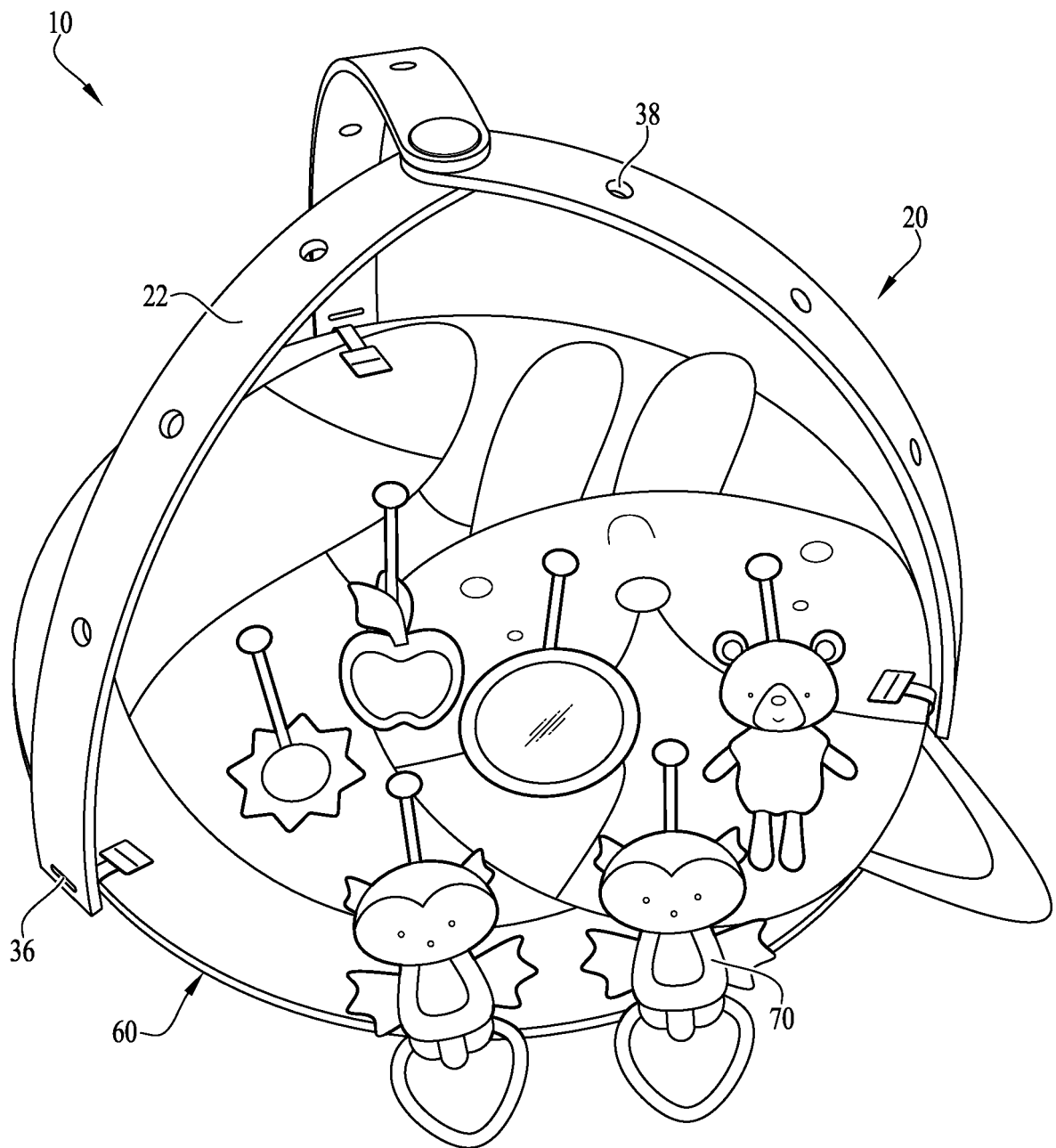

FIG. 1

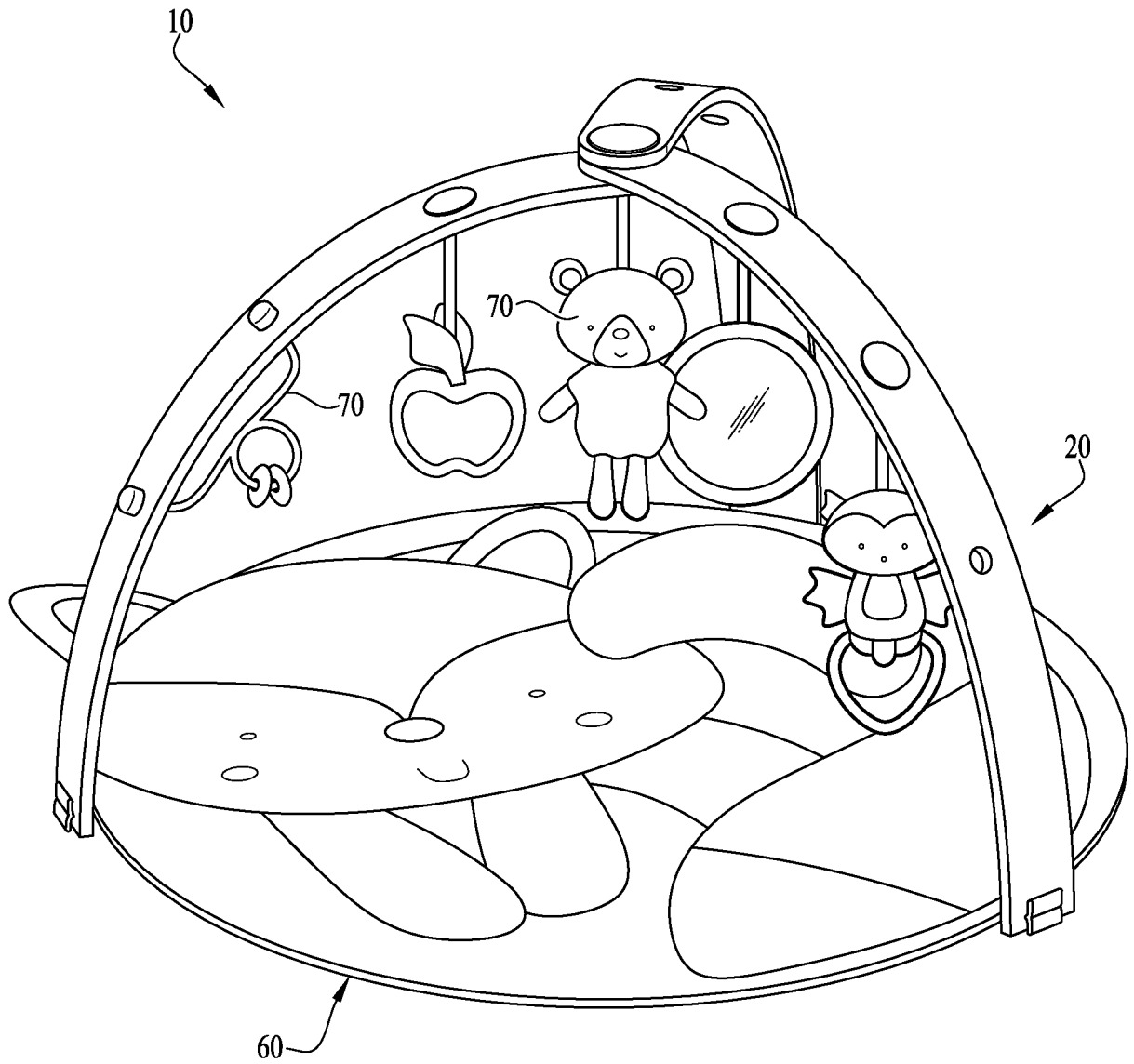
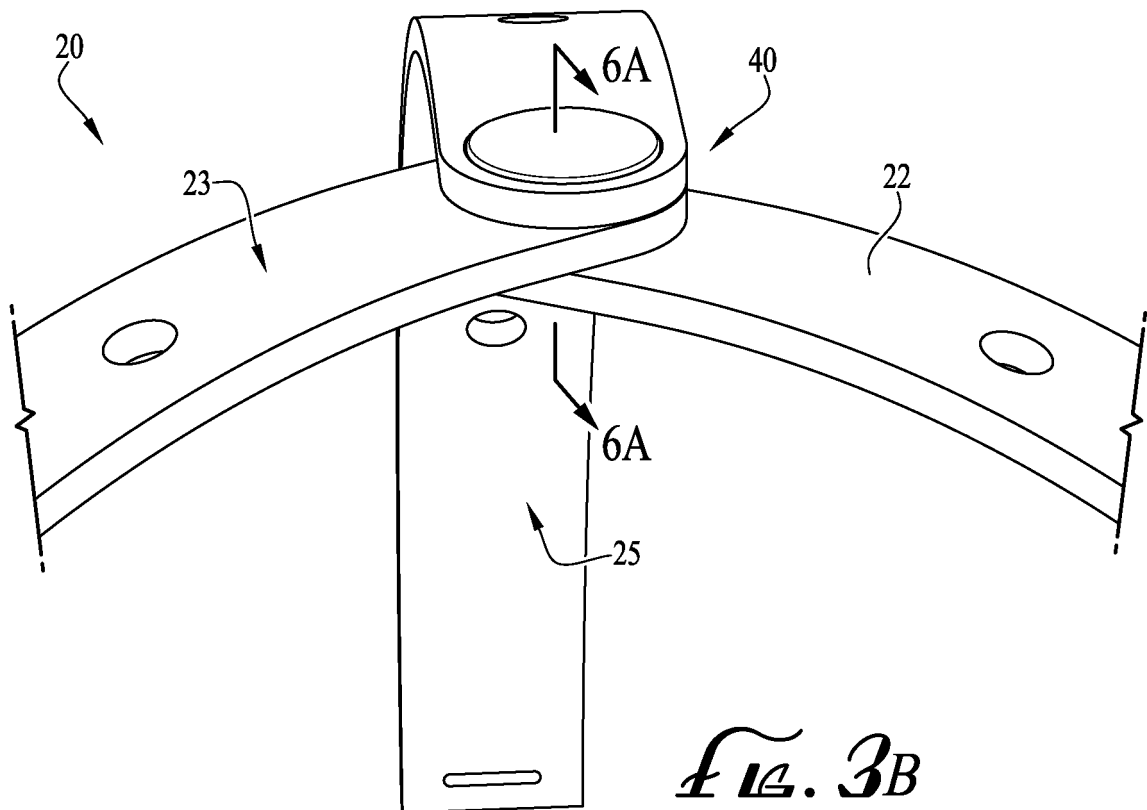
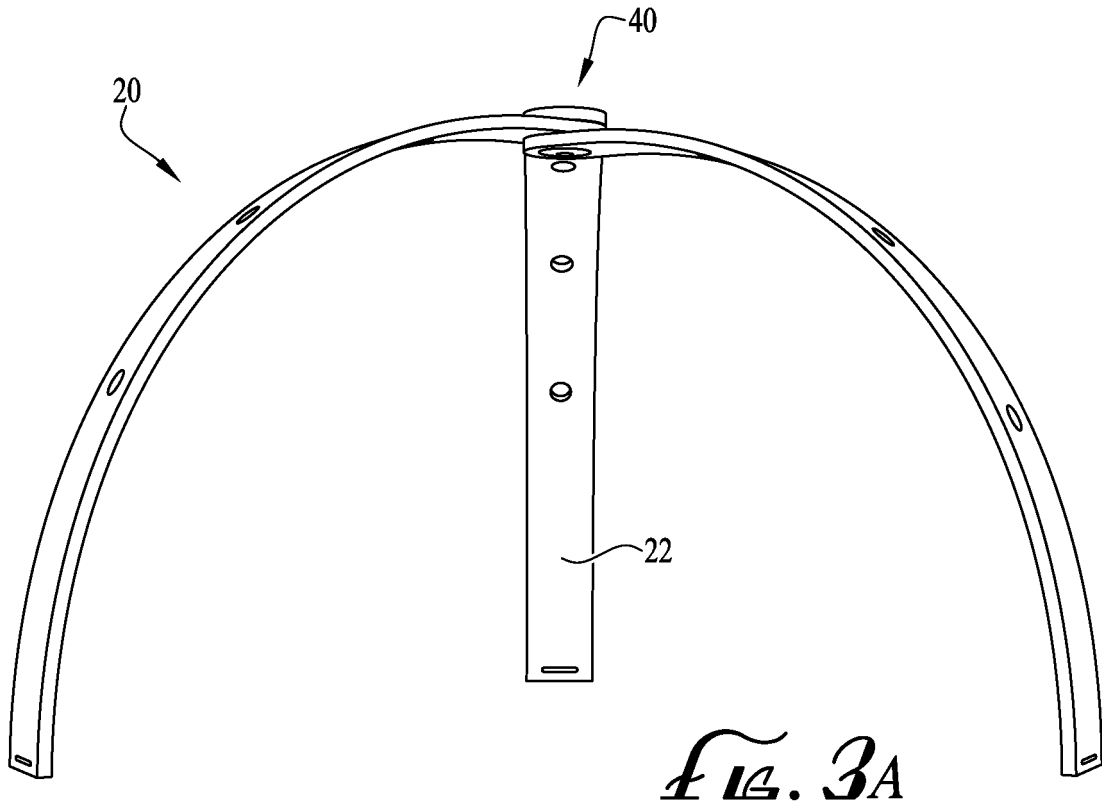

FIG. 2



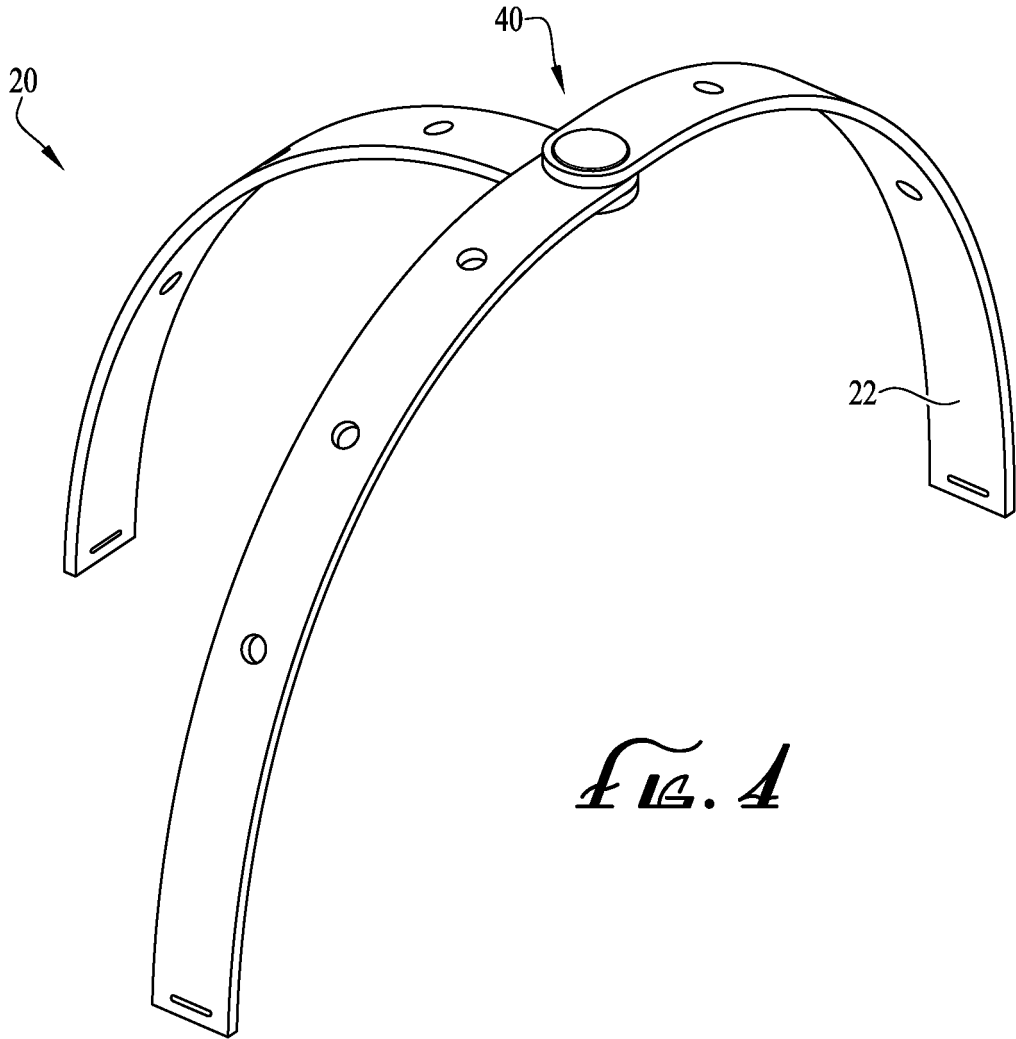

Fig. 4

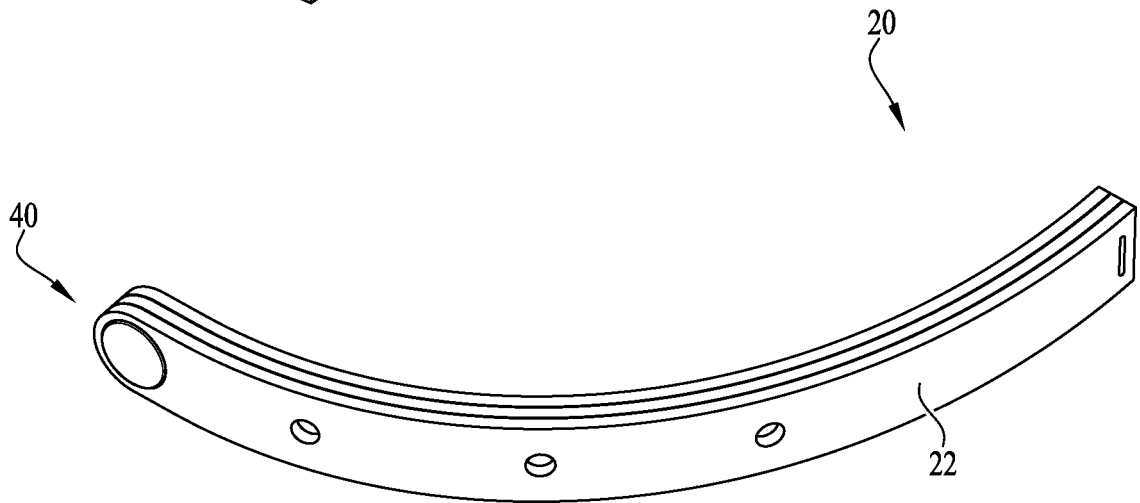

Fig. 5

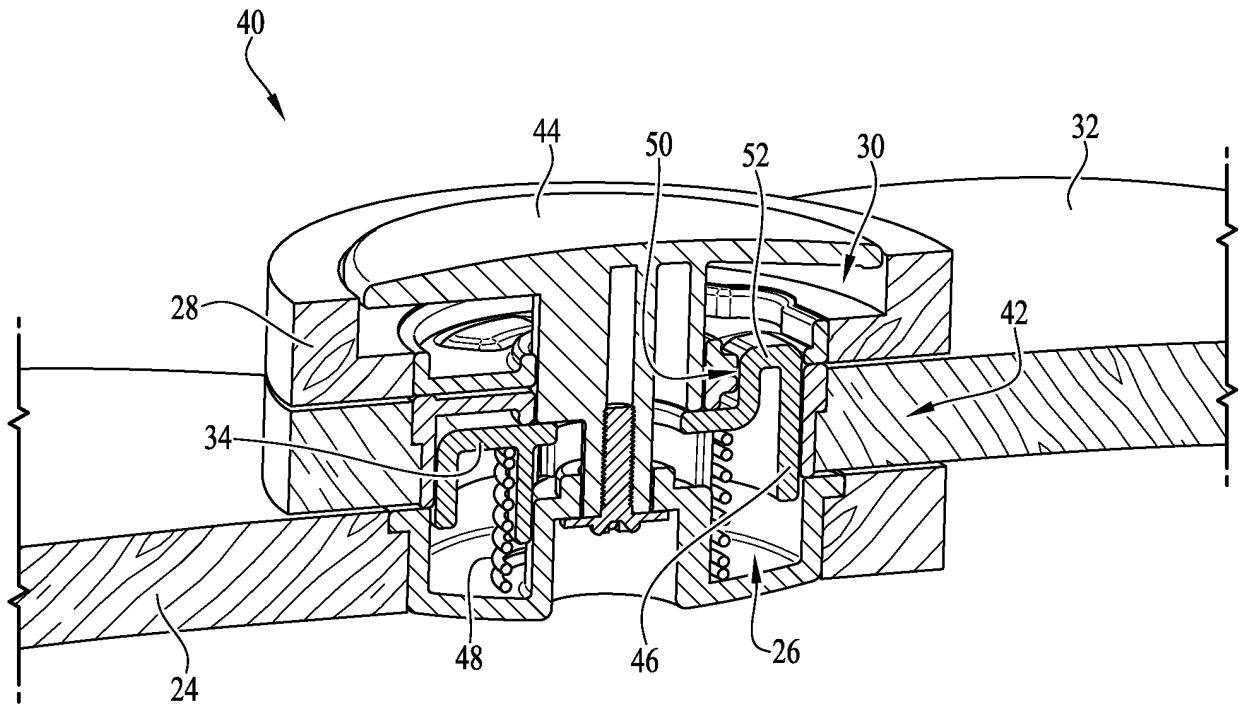

FIG. 0A

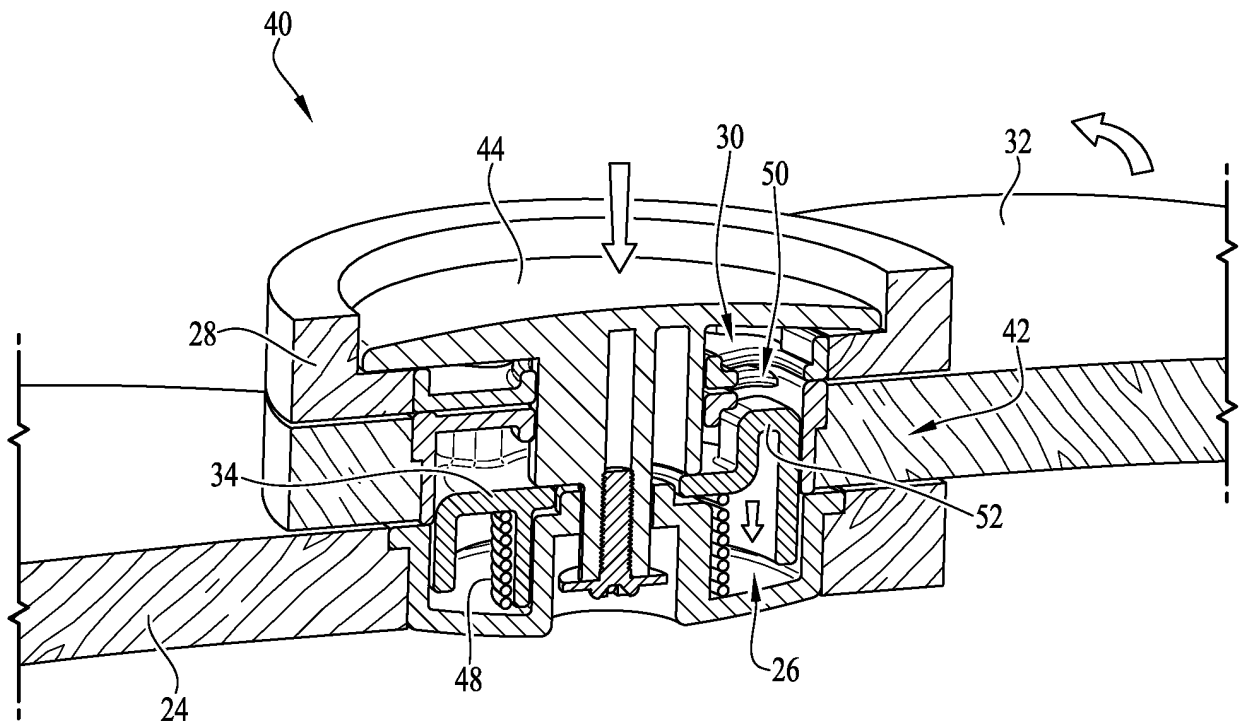

FIG. 0B

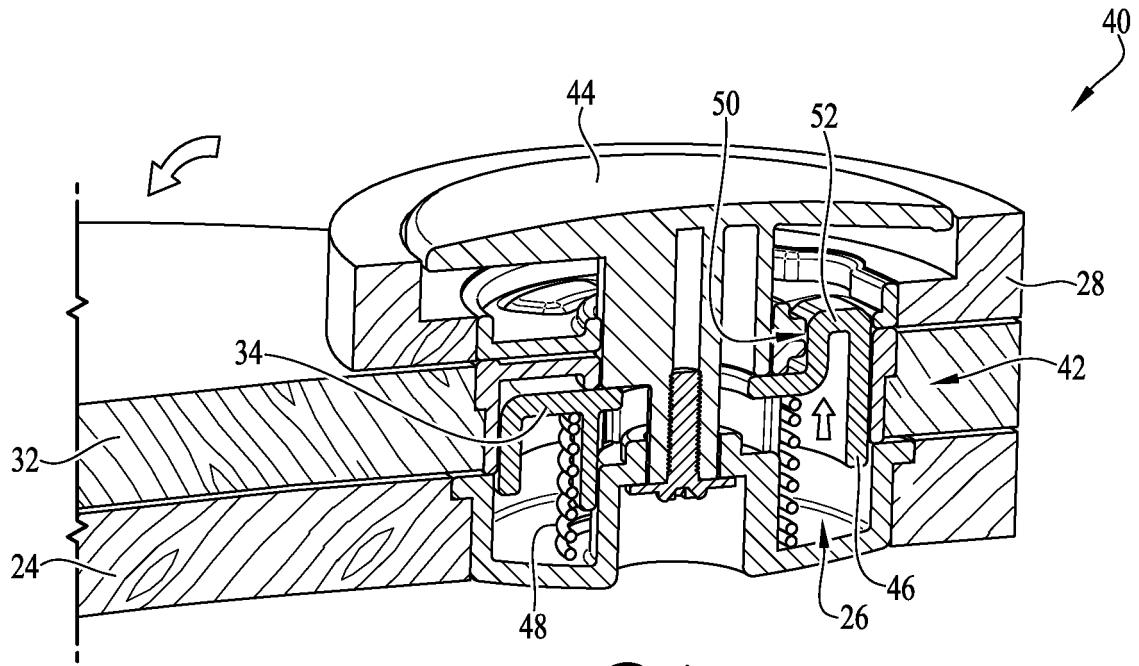

FIG. 6C

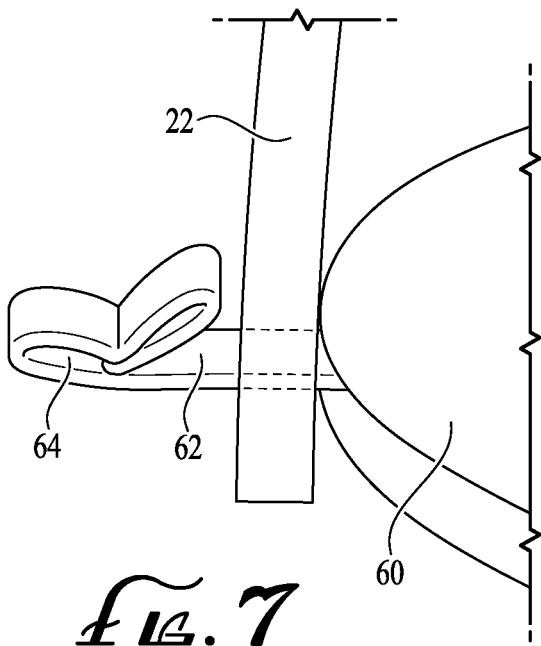

FIG. 7

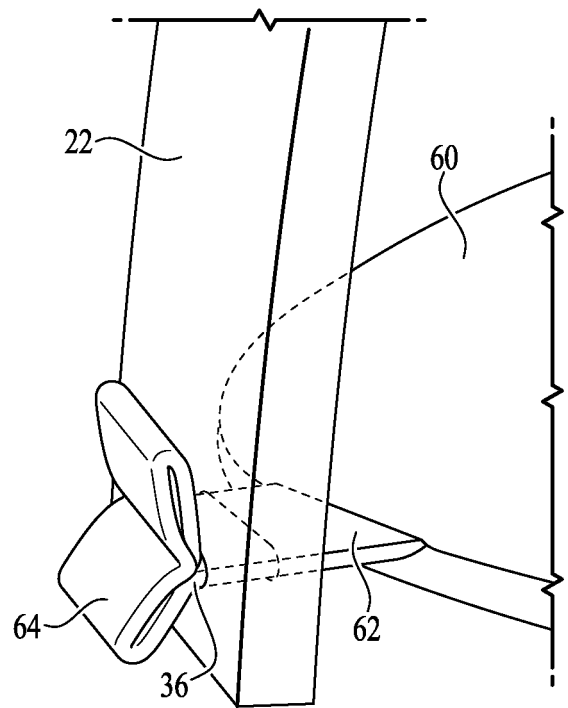

FIG. 8

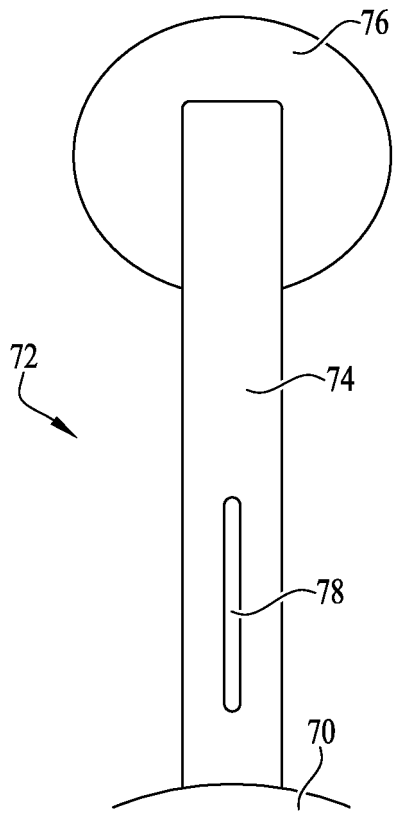

Fig. 9A

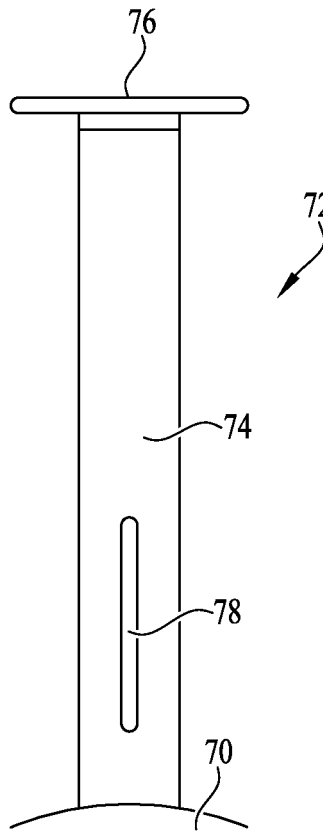

Fig. 9B

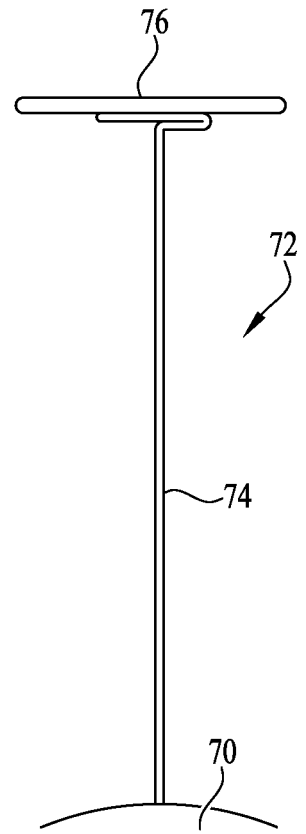

Fig. 9C

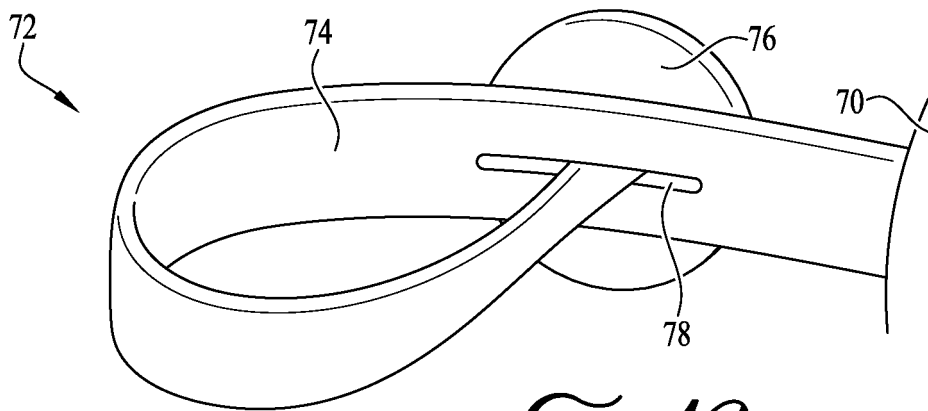
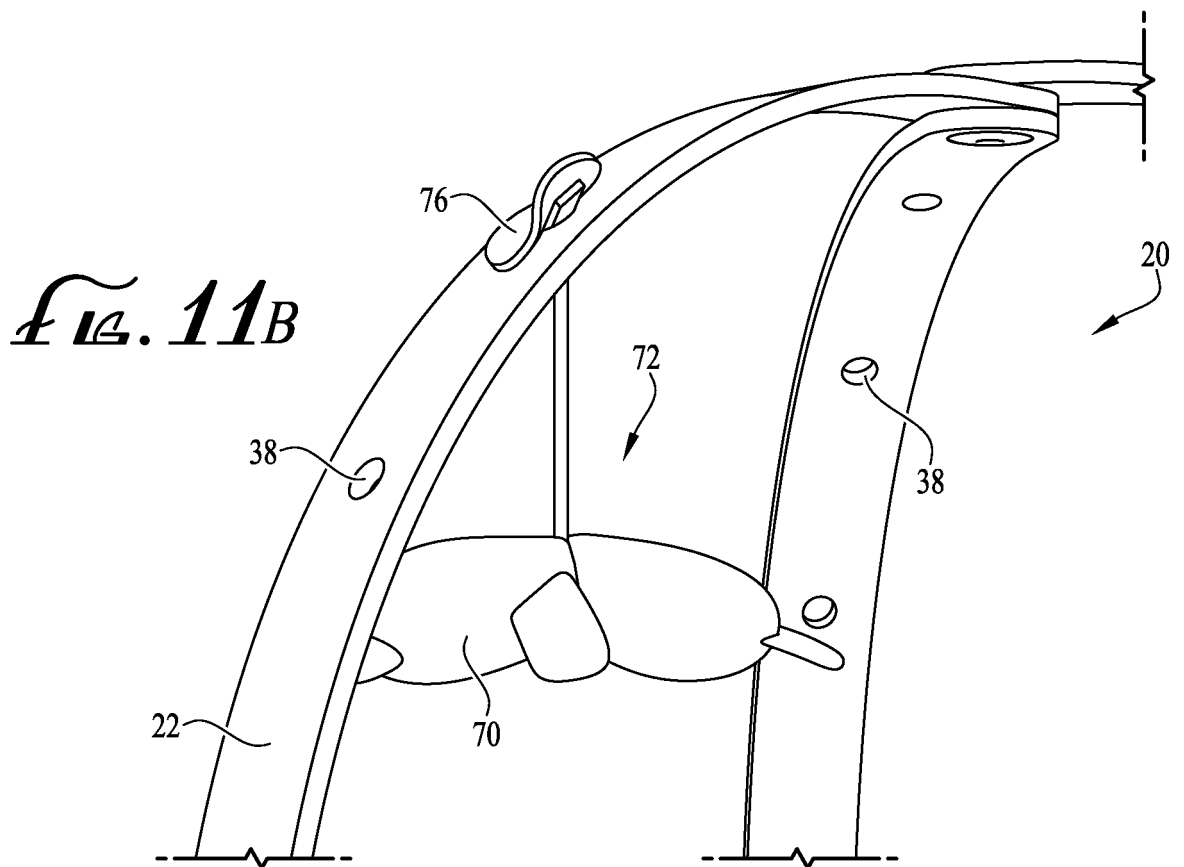
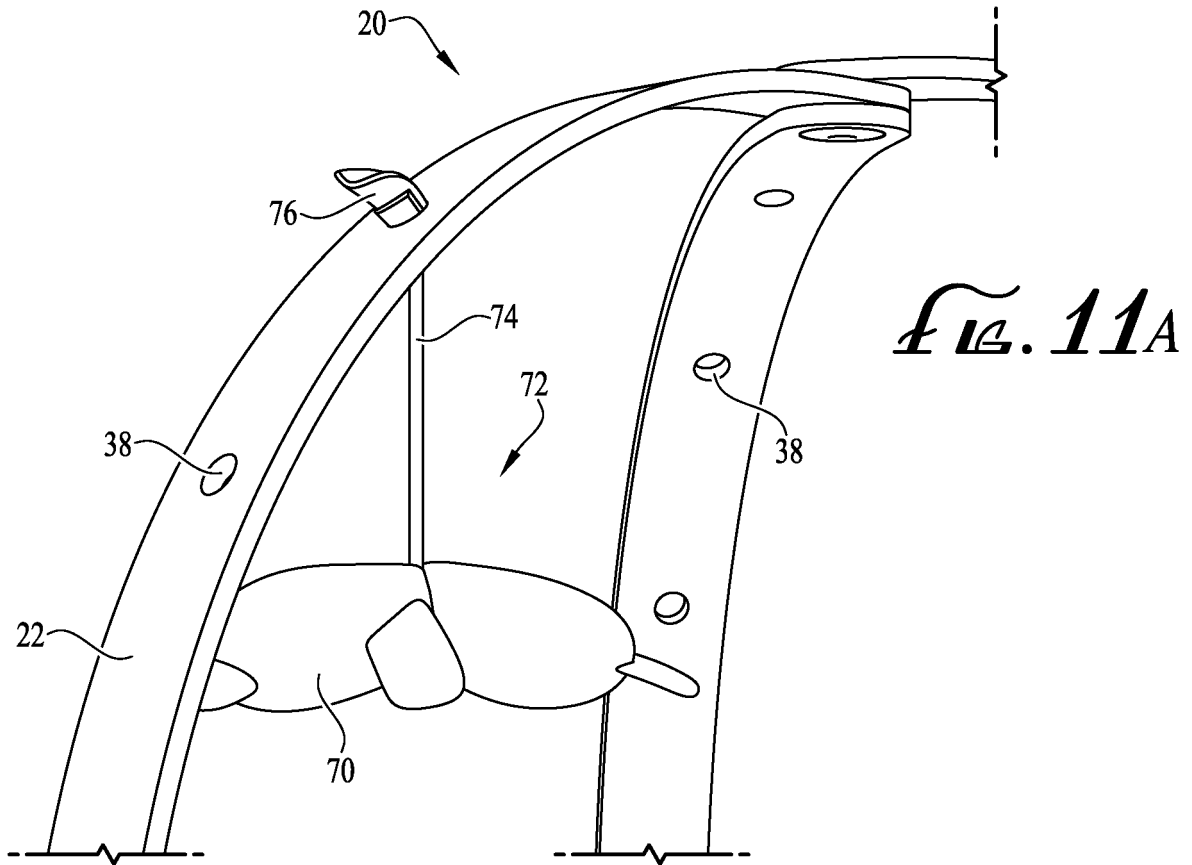

Fig. 10



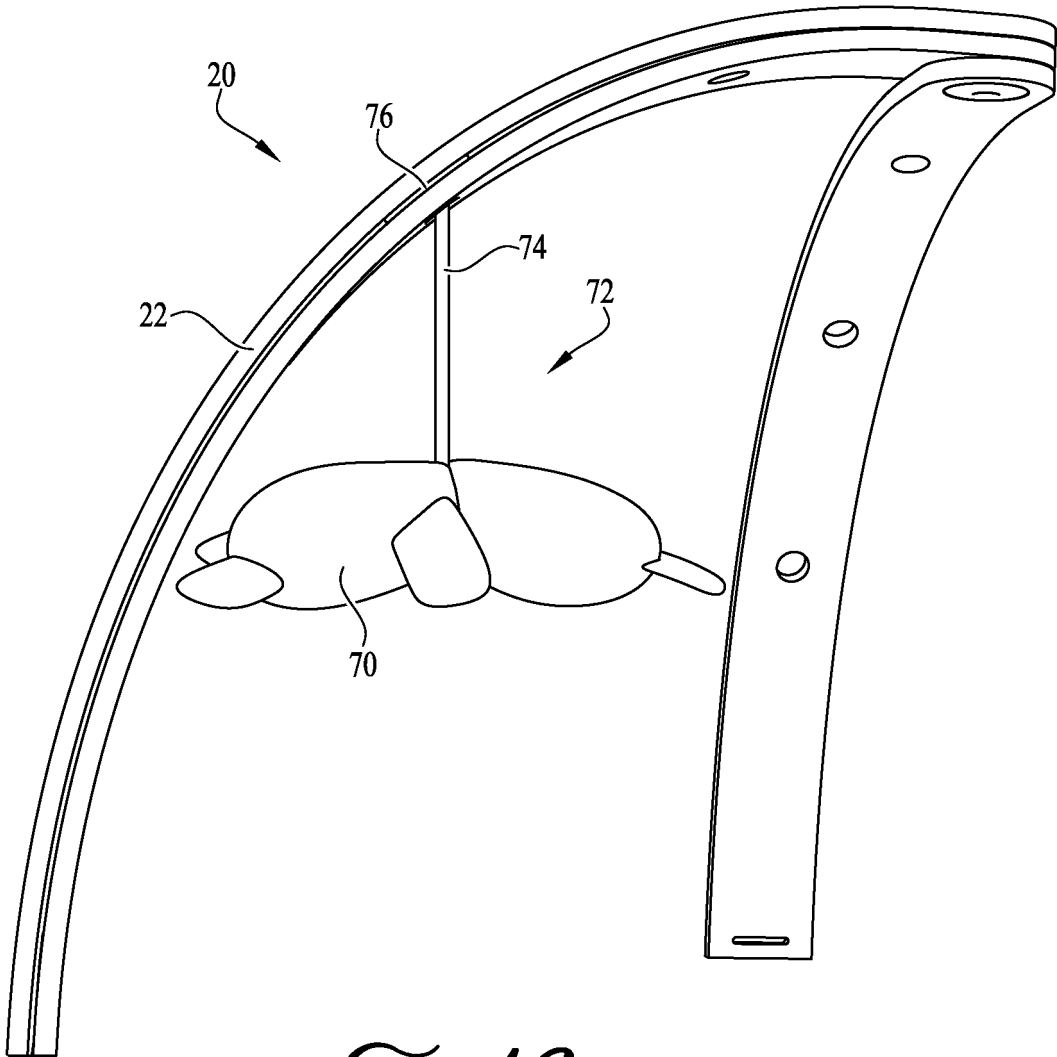

Fig. 12

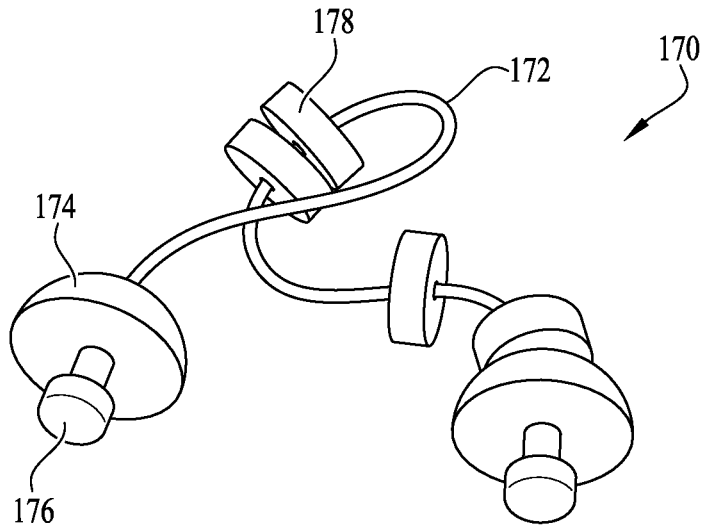

Fig. 13

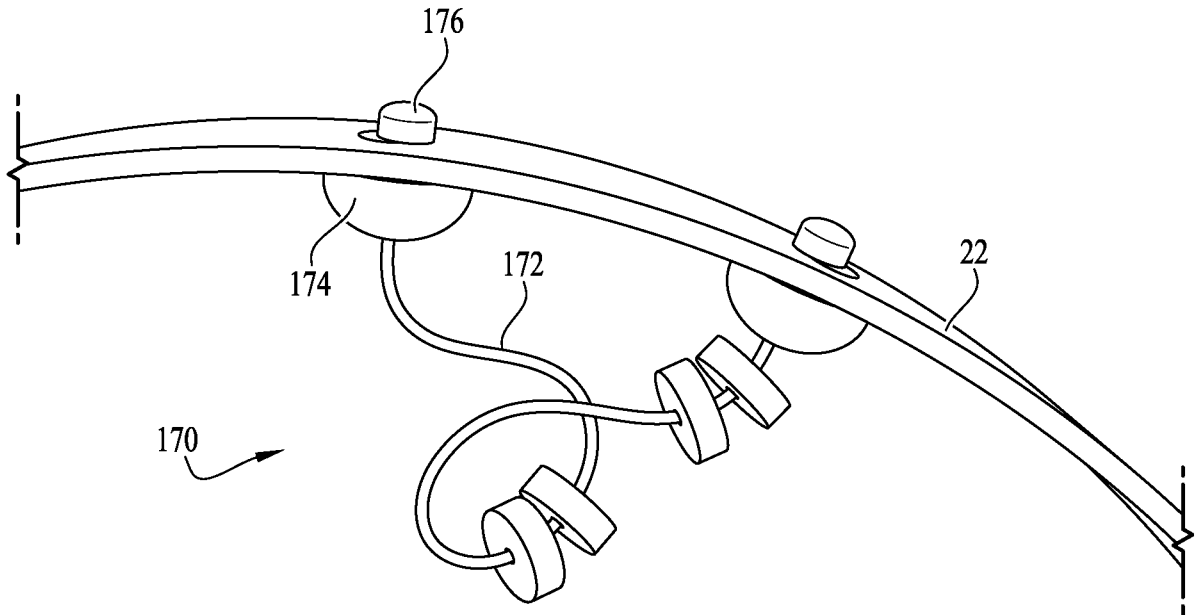

Fig. 14

REFERENCES CITED IN THE DESCRIPTION

This list of references cited by the applicant is for the reader's convenience only. It does not form part of the European patent document. Even though great care has been taken in compiling the references, errors or omissions cannot be excluded and the EPO disclaims all liability in this regard.

Patent documents cited in the description

- US 62394817 A [0001]
- US 20070066446 A1 [0004]