



(11) **EP 3 348 897 B1**

(12) **EUROPEAN PATENT SPECIFICATION**

(45) Date of publication and mention of the grant of the patent:  
**08.07.2020 Bulletin 2020/28**

(51) Int Cl.:  
**F21S 4/22** <sup>(2016.01)</sup> **F21V 21/02** <sup>(2006.01)</sup>  
**F21Y 115/10** <sup>(2016.01)</sup>

(21) Application number: **18151042.1**

(22) Date of filing: **10.01.2018**

(54) **A LIGHTING SYSTEM AND CORRESPONDING METHOD**

BELEUCHTUNGSSYSTEM UND ENSPRECHENDES VERFAHREN

SYSTEME D'ECLAIRAGE ET PROCEDE CORRESPONDANT

(84) Designated Contracting States:  
**AL AT BE BG CH CY CZ DE DK EE ES FI FR GB GR HR HU IE IS IT LI LT LU LV MC MK MT NL NO PL PT RO RS SE SI SK SM TR**

(30) Priority: **12.01.2017 IT 201700003095**

(43) Date of publication of application:  
**18.07.2018 Bulletin 2018/29**

(73) Proprietors:  
• **OSRAM GmbH**  
**80807 München (DE)**  
• **OSRAM S.P.A. - SOCIETA' RIUNITE OSRAM EDISON CLERICI**  
**20144 Milano (IT)**

Designated Contracting States:  
**IT**

(72) Inventors:  
• **FRANCK, Felix**  
**D-80689 München (DE)**  
• **ZANOTTO, Alberto**  
**I-35127 Padova (IT)**  
• **NASTOV, Aleksandar**  
**D-81671 München (DE)**

(74) Representative: **Bosotti, Luciano et al Buzzi, Notaro & Antonielli d'Oulx S.p.A.**  
**Corso Vittorio Emanuele II, 6**  
**10123 Torino (IT)**

(56) References cited:  
**EP-A1- 0 606 006 WO-A1-99/06759**  
**WO-A2-2008/134424 US-A1- 2010 238 655**  
**US-A1- 2014 313 722 US-B1- 6 186 645**

**EP 3 348 897 B1**

Note: Within nine months of the publication of the mention of the grant of the European patent in the European Patent Bulletin, any person may give notice to the European Patent Office of opposition to that patent, in accordance with the Implementing Regulations. Notice of opposition shall not be deemed to have been filed until the opposition fee has been paid. (Art. 99(1) European Patent Convention).

## Description

### Technical Field

**[0001]** The present description relates to lighting devices.

**[0002]** One or more embodiments may refer to lighting devices employing electrically powered light radiation sources such as solid-state sources, e.g. LED sources.

### Technological Background

**[0003]** Various lighting applications may envisage the use of devices including LED modules, which may exhibit a protection against the penetration of external agents, e.g. an IP protection degree.

**[0004]** Such devices may cause, at least in some conditions, problems regarding fixation, e.g. because of the little available space (e.g. in case of a hand rail application) or regarding the distribution of the light radiation emitted by the module itself (e.g. a batwing distribution).

**[0005]** One approach to solving said critical aspects may involve the use of a bi-adhesive tape. This solution, however, may cause difficulties if a module must be removed and optionally re-installed without suffering damages.

**[0006]** Although being characterized by the advantage of an easy implementation, the bi-adhesive mounting solution may be unsatisfactory as regards the retention force, also as a function of the material of the mounting surface.

**[0007]** In order to fix an e.g. LED lighting module onto a surface, a glue such as a silicone glue may be used. Also in this case, a critical aspect may concern the optional removal of the module without causing damages.

**[0008]** Gluing may also cause problems to the end user, due for instance to the risk of soiling the module during mounting or to the fact that the glue may not perform an instantaneous fixing action, and therefore may require the user to hold the module in position until the glue actually carries out its retention function.

**[0009]** Another possible drawback of glues may be due to a limited service life and/or to the possible change in colour.

**[0010]** Another approach involves the use of fixation clips, which are available in various shapes and materials and may be used to implement different fixation solutions, thanks to the differences in retention force and/or fixation method.

**[0011]** Such clips may exhibit the drawback of masking, at least partially, the light emitting surface, and consequently they may modify the emission distribution of the light beam: for example, they may affect the distribution of the light radiation, therefore originating dark spots along the module.

**[0012]** Said drawback, i.e. the negative impact on the uniformity of light emission lengthwise of the module, may also affect various solutions described in the fore-

going.

**[0013]** Still another solution may involve mounting tracks, e.g. piercing tracks, which are adapted to ensure a good result as regards uniformity, but may pose the risk of causing damages in case of a removal of the module which, once mounted on a track, may have been pierced or otherwise penetrated by various fixation elements.

**[0014]** Document US 6 186 645 B1 discloses a flexible lighting system including a flexible translucent rod and an attachment flange, with, preferably, the outer casing and the attachment flange integrally formed to facilitate installation. The flexible translucent rod includes an outer casing and a lighting core. The lighting core is disposed within an axial aperture defined by the outer casing and contains a series of lighting elements. A mounting arrangement is provided for engaging the flexible translucent rod, or a coupler portion thereof, and is arranged to facilitate coupling of the flexible lighting system to a mounting surface. The mounting surface may be penetrable, such as ground soil, unhardened building material, or the like. The mounting arrangement includes, in a penetrable surface application, an elongated web that penetrates the mounting surface. In an arrangement where the flexible translucent rod has an attachment portion, a correspondingly configured mounting channel is provided, the mounting channel having a base portion that is provided with a mounting facility, such as an adhesive layer or apertures for fasteners.

**[0015]** Document EP 0 606 006 A1 relates to a lighting strip system including interconnectable lighting strip sections and connector sections. The lighting strip sections include lighting means such as light emitting diodes or incandescent lamps encapsulated in a polymeric molding. The connector sections include metallic inserts or metallic strips which partially extend from the polymeric molding of the connector section wherein the metallic inserts or metallic strips are plugged into the lighting strip sections to form an electrical junction between an adjacent lighting strip section and connector section. The lighting strip system is particularly useful for pathway lighting

**[0016]** Documents such as 2014/313722 A1 and, to a lesser extent, WO 2008/134424 A2, WO 99/06759 A1, and US 2010/238655 A1 are also of interest for the invention.

### Object and Summary

**[0017]** One or more embodiments aim at overcoming the previously outlined drawbacks.

**[0018]** According to one or more embodiments, said object may be achieved thanks to a lighting system having the features set forth in claim 1 that follows.

**[0019]** One or more embodiments may also refer to a corresponding method as claimed in claim 10.

**[0020]** The claims are an integral part of the technical teaching provided herein with reference to embodiments.

**[0021]** One or more embodiments may offer one or more of the following advantages:

- absence of masking effects on the emitted light radiation; this is a critical point e.g. if the lighting device has a wide light radiation emission pattern. One or more embodiments enable the device to exhibit, in the final mounting condition, the desired radiation pattern without any deviation due for instance to mounting clips;
- possibility of implementing mounting solutions which are invisible from the outside, optionally by fixing the device in such a way as to mask the fixation structure: this may be a key aspect as regards the aesthetic appearance of the application;
- the retention force may remain effective also over long time periods, without alterations, even in the case when the mounting surface and/or the environmental conditions may forbid or damage an adhesive solution or may exert a deteriorating effect, possibly jeopardizing the fixation conditions.

#### Brief Description of the Figures

**[0022]** One or more embodiments will now be described, by way of non-limiting example only, with reference to the annexed Figures, wherein:

- Figure 1 is a cross-section view of embodiments,
- Figure 2 exemplifies further possible features of embodiments,
- Figure 3 is a perspective view of one of the elements visible in Figure 2,
- Figures 4 to 6 exemplify possible implementing modifications of embodiments,
- Figures 7 to 12, on one hand, and Figures 13 to 18, on the other hand, show various possible implementations of embodiments.

**[0023]** While possibly providing information related to the invention, embodiments as exemplified in Figures 7 to 18 are not in accordance with the invention as claimed.

**[0024]** It will be appreciated that, for simplicity and clarity of illustration, the various Figures may not be drawn to the same scale.

#### Detailed Description

**[0025]** In the following description, various specific details are given to provide a thorough understanding of exemplary embodiments according to the present specification. The embodiments may be practiced without one or several specific details, or with other methods, components, materials, etc. In other instances, well-known structures, materials or operations are not shown or described in detail in order to avoid obscuring the various aspects of the embodiments.

**[0026]** Reference throughout this specification to "one embodiment" or "an embodiment" means that a particular feature, structure, characteristic described in connection with the embodiment is included in at least one embodiment. Thus, the possible appearances of the phrases "in one embodiment" or "in an embodiment" in various places throughout this specification are not necessarily all referring exactly to the same embodiment. Furthermore, particular features, structures, or characteristics may be combined in any suitable manner in one or more embodiments.

**[0027]** The headings provided herein are for convenience only, and therefore do not interpret the extent of protection or scope of the embodiments.

**[0028]** In the Figures, reference 100 generally denotes a lighting device adapted to include a light radiation generator 120 having a structure known in itself. Some possible exemplary implementations of said structure are discussed in the following with reference to Figures 7ff.

**[0029]** According to the invention, it is possible to apply, onto generator 120, a profiled housing 122 of a light-permeable material (e.g. a transparent silicone material) adapted to allow for the propagation of the light radiation emitted by generator 120 outwards from device 100, e.g. at a rounded front surface of housing 122.

**[0030]** According to the invention, housing 122 may perform a protection action against the penetration of external agents into device 100, e.g. with an IP degree protection.

**[0031]** Generally speaking (apart from what will be specified in further detail in the following), devices such as the device (or module) 100 exemplified in the foregoing are to be deemed as known in themselves, which makes it unnecessary to provide a more detailed description herein. This also applies to the possibility of implementing such a device as an element of indefinite length (shown in cross section in the Figures), optionally flexible and/or adapted to be cut to length according to the application and usage needs.

**[0032]** One or more embodiments may deal with the problem of enabling mounting said device onto a mounting structure S.

**[0033]** One or more embodiments may favour mounting device 100 onto a wide range of mounting structures S. Said structures may include for instance a wall (e.g. a ceiling), an architectural element (e.g. a hand rail), a furnishing element of any nature, both in buildings and in moving structures such as vehicles and the like: this list is of course merely exemplary, and does not limit the embodiments.

**[0034]** According to the invention, the mounting of device 100 takes place via a fixation element 10.

**[0035]** In one or more embodiments, element 10 may include a sort of profiled track adapted to be coupled to structure S, and having at least one formation for coupling with device 100.

**[0036]** In one or more embodiments as exemplified in Figures 1 to 6, element 10 may include a channel-shaped

track, including a central or core wall 10a and side walls 10a extending sidewise of central wall 10a.

**[0037]** In one or more embodiments, each side wall 10b is adapted to form a rib-like protrusion, which may be inserted in a corresponding longitudinal groove 100b provided in device 100.

**[0038]** According to the invention, the groove (s) 100b (which may be provided in the same number as the rib-like protrusions 10b in element 10) are located at the back portion (lower portion in Figures 1 and 2) of the housing of device 100.

**[0039]** According to the invention, the groove (s) or slot(s) 100b are provided in a part of device 100 (e.g. the housing or profile 122) adapted to include a compliant material (e.g. a silicone material).

**[0040]** In one or more embodiments, the rib(s) 10b may therefore penetrate the groove(s) 100b and may be retained therein, thanks to the deformability of the walls of the groove(s) 100b.

**[0041]** In one or more embodiments, the rib(s) 10b may include sculpturing 10c adapted to originate a firmer retention, e.g. thanks to a locking mechanism.

**[0042]** For example Figures 1, 2 and 4 exemplify a tooth-like sculpturing 10c, e.g. with a sawtooth profile adapted to implement a hooking coupling with the walls of the groove(s) 100b.

**[0043]** In one or more embodiments, the sculpturing features 10c may be present in different numbers and with different profiles, as shown - by way of example only - in Figure 5, which shows sculpturing features 10c arranged in pairs on each side wall 10d, and having a square/rectangular cross section, or in Figure 6, showing sculpturing features 10c which extend (as a single sculpturing feature on each side wall 10b) with a rounded, e.g. lobe-shaped, cross-section profile.

**[0044]** It will be appreciated, moreover, that in one or more embodiments:

- sculpturing 10c may be provided not on the outer surface of side walls 10b, but rather on the inner surface thereof, or both on the outer and on the inner surface,
- in an embodiment not claimed, the coupling arrangement shown herein between device 100 and element 10 may be reversed, with device 100 having one or more protruding formations adapted to penetrate one or more longitudinal grooves of element 10.

**[0045]** One or more embodiments implementing the latter solution are exemplified in Figures 7ff.

**[0046]** Figures 7 to 11 refer to a device 100 wherein the protection against the penetration of external agents is achieved through the use of a channel-shaped housing, while Figures 13 to 17 refer to an equally protected device 100 wherein the protection may be achieved during the forming (moulding) step of device 100.

**[0047]** Moreover, said Figures exemplify possible implementation details of the light radiation generator which

is generally denoted as 120 in Figure 1.

**[0048]** For example, in one or more embodiments as exemplified in Figures 7ff, generator 120 may include electrically powered light radiation sources, such as one or more LED sources. References 1 and 2 appearing in Figures 7ff respectively denote the LED source (e.g. emitting in the blue range, with phosphor conversion into visible light) and the associated package.

**[0049]** In the same Figures, reference 7 denotes a substrate (substantially similar to a Printed Circuit Board, PCB) for mounting source(s) 1, 2.

**[0050]** Reference 8 denotes an insert (or spacer), optionally of a thermally conductive material, which in one or more embodiments may be interposed between substrate 7 and the bottom wall of a channel-shaped housing 9.

**[0051]** In one or more embodiments, as exemplified in Figures 7 to 11, housing 9 is adapted to host the substrate 7, whereon source(s) 1, 2 are arranged, the channel-like shape of housing 9 being adapted to be filled with a potting mass.

**[0052]** In one or more embodiments, the potting mass may include a material 5, e.g. a white or reflective, generally light-impermeable material, adapted e.g. to mask from observation from the outside of device 100 electrical/electronic components and devices which may be mounted on the front surface of substrate 7, as well as a further light-permeable material 3 (e.g. a transparent or diffusive material) which allows the light radiation produced by source 1 to propagate outwards from device 100.

**[0053]** In one or more embodiments substrate 7, insert 8 (if present), housing 9 and masses 5 and 3 are adapted to include a flexible material, so that device 100 is generally flexible.

**[0054]** Figures 7 to 11 exemplify various implementation solutions for one or more ribs 91, adapted to protrude from the central wall of housing 9 (in the direction away from the front side of device 9, from which the light radiation is diffused), so as to be inserted into one or more corresponding slots or grooves 101, 102 adapted to be provided in the fixation element 10.

**[0055]** For example, in one or more embodiments, the presence may be envisaged of one or more ribs 91 having (transversally of the extension direction of device 100) a width increasing in the distal direction, away from the body of device 100, so as to originate a dove-tail joint with one or more corresponding cavities 101, 102 provided in the fixation element 10.

**[0056]** Specifically, Figure 11 (and, in a complementary fashion, Figure 12) exemplify the possibility, in one or more embodiments, of envisaging the presence of a plurality of ribs 91 of this kind, each being adapted to engage a corresponding slot/groove 101, 102 of the fixation element 10.

**[0057]** Figures 7 to 10 exemplify various features which may be present in one (or each) of said ribs 91.

**[0058]** For example:

- Figure 8 exemplifies the possibility for the distal edges of rib 91 to have edge portions 92 protruding from the rounded profile,
- Figure 9 exemplifies the possible presence of a central carving 93, adapted to favour the transversal shrinking of rib 91,
- Figure 10 exemplifies the possible presence of chamferings or bevels 94 at the distal edges of rib 91 and, at the same time, the possible presence of edge portions 92 which are recessed into, and not protruding from, the rounded profile.

**[0059]** Similar or complementary features may also be present in the fixation element, as exemplified by the rounded/chamfered edges denoted as 104 in Figure 12 and in Figure 18.

**[0060]** In this respect it will be appreciated that, in one or more embodiments, the implementation features or details exemplified in each of the Figures annexed to the present description are adapted to be applied - individually or in mutual combination - to embodiments exemplified in any of the other Figures.

**[0061]** This aspect is shown for example in Figures 13 to 18, wherein one or more features of rib(s) 91 exemplified with reference to Figures 7 to 12 are applied to a device 100 having a protection obtained by moulding (Moulded Flex Protect), wherein substrate 7 hosting the light radiation source(s) 1, 2 is sealed against the penetration of external agents, by being moulded between:

- a first housing portion 6, which faces the back surface of substrate 7 accommodated therein (from which rib 91 may extend), and
- a second portion 4, which completes the sealing action against the penetration of external agents.

**[0062]** In one or more embodiments, the first portion 6 may include a white or translucent, e.g. light-impermeable, material, while portion 4 may include transparent or diffusive material, i.e. a light-permeable material, enabling the propagation towards the outside of device 100 of the light radiation generated by source(s) 1, 2.

**[0063]** One or more embodiments may therefore envisage at least one protruding formation (rib) in one of device 100 and fixation element 10, and at least one corresponding slot or groove e.g. in the other element.

**[0064]** According to the invention, as exemplified in Figures 1 and 2, the at least one protruding formation (rib) is provided (see e.g. 10b) in the fixation element 10, with one or more corresponding grooves (see e.g. 100b) provided in device 100.

**[0065]** Once again by way of example, in one or more embodiments not claimed, as exemplified in Figures 7ff the at least one protruding formation (rib) is provided (see e.g. 91) in device 100, with one or more corresponding grooves (see e.g. 101, 102) provided in the fixation element 10.

**[0066]** In one or more embodiments as exemplified in

Figures 7ff, the coupling between such complementary portions (protruding formation(s) and groove(s)) may be implemented by a dove-tail joint.

**[0067]** In one or more embodiments it is possible to take advantage of the flexibility of the materials denoted as 3, 5, 9 as well as 4 and 6, both for the separation from a mould (see e.g. the embodiments exemplified in Figures 13 to 17) and for the mounting (and removal), which may optionally be performed repeatedly, of device 100 to and from the fixation element 10.

**[0068]** In one or more embodiments, the presence of rounded edges (as exemplified in Figure 6 or as denoted as 92 in Figures such as Figure 9 or Figure 15) may simplify such mounting and removing operations.

**[0069]** The possible presence of a central slot or groove, such as the one denoted as 93 in Figures such as Figures 9 and 13, may further simplify said mounting operations, by favouring the transversal shrinking of rib 91.

**[0070]** The mounting/removal operation may also be simplified by the presence of chamferings or bevels, such as the ones denoted as 94 in Figure 10 or in Figure 16.

**[0071]** One or more embodiments may enable a simple mounting of device 100 onto element 10 by a simple snap-on operation, optionally with the application of low side forces.

**[0072]** The removal operation of device 100 from fixation element 10 may take place, in one or more embodiments, simply through a pulling action exerted onto device 100 in a direction away from fixation element 10.

**[0073]** One or more embodiments may enable an accurate positioning of fixation element 10, which may be advantageous for signage applications, the possibility being given for example of initially defining the position of fixation element 10 with accuracy, without involving the lighting device 100 in the operation.

**[0074]** In one or more embodiments, the complementary formations (rib(s) 10b, 91 and corresponding cavities 100b, 101, 102) may be implemented in different ways, for example during the manufacturing process of device 100 (e.g. during the extrusion of housing 3, 4, 6, 9), or optionally with a cutting process, e.g. laser cutting.

**[0075]** In one or more embodiments, the sizes and shapes of said complementary formations may depend on the forming process thereof, e.g. with different cutting methods; for example, in the case of an extrusion process, the cavities may be larger than those implemented via laser cutting.

**[0076]** In one or more embodiments, the retention force which may be achieved thanks to the coupling of said complementary features may be proportional to the size thereof, e.g. to the size of the cavity.

**[0077]** For example, a small-sized cavity may exert a higher retention force than a large-sized cavity. On the other hand, the choice of a large-sized cavity may simplify the mounting and installation process.

**[0078]** In one or more embodiments, the choice of a given shape of the complementary features may depend

e.g. on the desired properties as regards the force needed for installing device 100 onto fixation element 10, and/or on the desired retention force. Generally speaking, it may be assumed that, the higher the force needed during installation, the higher the retention force achieved.

**[0079]** As regards the mounting procedure of fixation element 10, it may be stated that for example a generally rigid element 10 (e.g. a track of a light metal material) may be preferable for linear applications, the choice of a thermally conductive material being also useful for cooling, i.e. for dissipating the heat produced by the light radiation source(s) in operation.

**[0080]** The choice of a flexible element 10, which may again include a metal material, may be useful in nonlinear applications, wherein a certain adaptability of device 100 to the mounting structure is sought after.

**[0081]** It will be appreciated, moreover, that one or more embodiments are adapted to be employed in conjunction both with modules 100 of a certain length and with modules having reduced length.

**[0082]** Once again it is to be noted that, in one or more embodiments, the implementation features or details exemplified in each of the Figures annexed to the present specification are adapted to be applied - individually or in mutual combination - to embodiments exemplified in any other Figure.

**[0083]** One or more embodiments may be implemented as:

- a lighting system including device 100 and element 10;
- device 100 and element 10, as components of said system, which are optionally provided separately and are subsequently assembled into the system;
- a corresponding kit including, e.g. in a single package, device 100 and element 10, and
- a method of employing the system.

**[0084]** Without prejudice to the basic principles, the implementation details and the embodiments may vary, even appreciably, with respect to what has been described herein by way of non-limiting example only, without departing from the extent of protection.

**[0085]** The extent of protection is determined by the annexed claims.

## Claims

1. A lighting system, including:

- an elongated lighting device (100) including a front light emission surface (122) and a back surface opposite said front surface, wherein the lighting device (100) includes a protected device including a flexible sealing encapsulation (122),
- a fixation element (10) coupleable to a mount-

ing structure (S),

wherein the lighting device (100) and the fixation element (10) include complementary formations (10b, 100b) mutually engageable in a form-coupling relationship, and wherein: said complementary formations include at least one groove (100b) provided in said flexible sealing encapsulation (122) at said back surface of the lighting device (100) and at least one rib-like protrusion (10b) in the fixation element (10), **characterised in that** the flexible sealing encapsulation (122) consists of light-permeable material.

2. The lighting system of claim 1, wherein said complementary formations include sculpturing (10c) on at least one (10b) of said complementary formations.

3. The lighting system of claim 2, wherein said sculpturing (10c) includes tooth-like formations.

4. The lighting system of any of the previous claims, wherein said complementary formations include rounded regions (10c).

5. The lighting system of any of the previous claims, wherein said complementary formations include material (100b) facilitating deformation of the complementary formations during coupling.

6. The lighting system of claim 5, wherein said complementary formations include material (100b) facilitating deformation of the complementary formations during coupling via elastic coupling.

7. The lighting system of any of the previous claims, wherein the complementary formations include a plurality of pairs (10b, 100b) of mutually engageable complementary formations.

8. The lighting system of any of the previous claims, wherein said lighting device (100) includes at least one solid-state light radiation source (1, 2).

9. The lighting system of claim 8, wherein said lighting device (100) includes at least one LED source (1, 2).

10. A method of providing a lighting device, wherein the method includes:

- providing an elongated lighting device (100) including a front light emission surface (122) and a back surface opposite said front surface, and a fixation element (10) coupleable to a mounting structure (S), wherein the lighting device (100) includes a protected device including a flexible sealing encapsulation (122),
- providing the lighting device (100) and the fixation element (10) with complementary forma-

tions (10b, 100b) mutually engageable in a form-coupling relationship, wherein:  
 the flexible sealing encapsulation (122) consists of light-permeable material and said complementary formations include at least one groove (100b) provided in said flexible sealing encapsulation (122) at said back surface of the lighting device (100) and at least one rib-like protrusion (10b) in the fixation element (10),  
 and  
 - coupling the lighting device (100) and the fixation element (10) by bringing said complementary formations (10b, 100b; 91, 101, 102) into a form-coupling relationship.

11. The method of claim 10, including coupling the fixation element (10) to a mounting structure (S).
12. The method of claim 11, including coupling the fixation element (10) to a mounting structure (S) prior to coupling the lighting device (100) and the fixation element (10).

#### Patentansprüche

1. Beleuchtungssystem, einschließlich:

- eine langgestreckte Beleuchtungsvorrichtung (100), die eine vordere Lichtaustrittsfläche (122) und eine der vorderen Fläche gegenüberliegende hintere Fläche aufweist, wobei die Beleuchtungsvorrichtung (100) eine geschützte Vorrichtung einschließlich einer flexiblen, abdichtenden Verkapselung (122) einschließt,
- ein Befestigungselement (10), das mit einer Montagestruktur (S) gekoppelt werden kann,

wobei die Beleuchtungsvorrichtung (100) und das Befestigungselement (10) komplementäre Formationen (10b, 100b) einschließen, die gegenseitig in einer formkoppelnden Beziehung in Eingriff gebracht werden können, und wobei:

- die komplementären Formationen mindestens eine Nut (100b), die in der flexiblen abdichtenden Verkapselung (122) an der hinteren Fläche der Beleuchtungsvorrichtung (100) bereitgestellt ist, und mindestens einen rippenartigen Vorsprung (10b) im Befestigungselement (10) einschließen, **dadurch gekennzeichnet, dass** die flexible abdichtende Verkapselung (122) aus lichtdurchlässigem Material besteht.

2. Beleuchtungssystem nach Anspruch 1, wobei die komplementären Formationen die Skulptur (10c) auf mindestens einer der komplementären Formationen (10b) einschließen.

3. Beleuchtungssystem nach Anspruch 2, wobei die Skulptur (10c) zahnähnliche Formationen einschließt.

4. Beleuchtungssystem nach irgendeinem der vorhergehenden Ansprüche, wobei die komplementären Formationen abgerundete Bereiche (10c) einschließen.

5. Beleuchtungssystem nach irgendeinem der vorhergehenden Ansprüche, wobei die komplementären Formationen Material (100b) einschließen, das die Verformung der komplementären Formationen während des Koppelns erleichtert.

6. Beleuchtungssystem nach Anspruch 5, wobei die genannten komplementären Formationen Material (100b) einschließen, das die Verformung der komplementären Formationen während des Koppelns über elastisches Koppeln erleichtert.

7. Beleuchtungssystem nach irgendeinem der vorhergehenden Ansprüche, wobei die komplementären Formationen eine Vielzahl von Paaren (10b, 100b) von komplementären Formationen einschließen, die gegenseitig in Eingriff gebracht werden können.

8. Beleuchtungssystem nach irgendeinem der vorhergehenden Ansprüche, wobei die Beleuchtungsvorrichtung (100) mindestens eine Festkörper-Lichtstrahlungsquelle (1, 2) einschließt.

9. Beleuchtungssystem nach Anspruch 8, wobei die Beleuchtungsvorrichtung (100) mindestens eine LED Quelle (1, 2) einschließt.

10. Verfahren zum Bereitstellen einer Beleuchtungsvorrichtung, wobei das Verfahren einschließt:

- Bereitstellen einer langgestreckten Beleuchtungsvorrichtung (100), die eine vordere Lichtaustrittsfläche (122) und eine der vorderen Fläche gegenüberliegende hintere Fläche aufweist, sowie ein Befestigungselement (10), das mit einer Montagestruktur (S) gekoppelt werden kann, wobei die Beleuchtungsvorrichtung (100) eine geschützte Vorrichtung einschließlich einer flexiblen, abdichtenden Verkapselung (122) einschließt,

- Bereitstellen der Beleuchtungsvorrichtung (100) und des Befestigungselements (10) mit komplementären Formationen (10b, 100b), die gegenseitig in einer formkoppelnden Beziehung in Eingriff gebracht werden können, wobei:

- die flexible abdichtende Verkapselung (122) aus lichtdurchlässigem Material besteht und die komplementären Formationen mindestens eine Nut (100b), die in der flexiblen abdichtenden

Verkapselung (122) an der hinteren Fläche der Beleuchtungsvorrichtung (100) bereitgestellt ist, und mindestens einen rippenartigen Vorsprung (10b) im Befestigungselement (10) einschließen, und  
 - Koppeln der Beleuchtungsvorrichtung (100) und des Befestigungselements (10), indem die komplementären Formationen (10b, 100b, 91, 101, 102) in eine formkoppelnde Beziehung gebracht werden.

11. Verfahren nach Anspruch 10, einschließlich des Koppelns des Befestigungselements (10) an eine Montagestructur (S).

12. Verfahren nach Anspruch 11, einschließlich des Koppelns des Befestigungselements (10) mit einer Montagestructur (S) vor dem Koppeln der Beleuchtungsvorrichtung (100) und des Befestigungselements (10).

## Revendications

1. Un système d'éclairage, comprenant :

- un composant d'éclairage allongé (100) comprenant une surface d'émission lumineuse frontale (122) et une surface dorsale opposée à ladite surface frontale, le composant d'éclairage (100) comprenant un composant protégé incluant une encapsulation d'étanchéité flexible (122),
- un élément de fixation (10) pouvant être couplé à une structure de montage (S),

dans lequel le composant d'éclairage (100) et l'élément de fixation (10) comprennent des conformations complémentaires (10b, 100b) pouvant être mutuellement emboîtées en une relation de couplage des formes, et dans lequel :

lesdites conformations complémentaires comprennent au moins une gorge (100b) formée dans ladite encapsulation d'étanchéité flexible (122) sur ladite surface dorsale du composant d'éclairage (100) et au moins un relief en forme de nervure (10b) dans l'élément de fixation (10), **caractérisé en ce que** l'encapsulation d'étanchéité flexible (122) est constituée d'un matériau perméable à la lumière.

2. Le système d'éclairage de la revendication 1, dans lequel lesdites conformations complémentaires comprennent une structuration (10c) sur au moins l'une (10b) desdites conformations complémentaires.

3. Le système d'éclairage de la revendication 2, dans lequel ladite structuration (10c) comprend des conformations en forme de dents.

4. Le système d'éclairage de l'une des revendications précédentes, dans lequel lesdites conformations complémentaires comprennent des régions arrondies (10c).

5. Le système d'éclairage de l'une des revendications précédentes, dans lequel lesdites conformations complémentaires comprennent un matériau (100b) facilitant la déformation des conformations complémentaires au moment du couplage.

6. Le système d'éclairage de la revendication 5, dans lequel lesdites conformations complémentaires comprennent un matériau (100b) facilitant la déformation des conformations complémentaires au moment du couplage par couplage élastique.

7. Le système d'éclairage de l'une des revendications précédentes, dans lequel les conformations complémentaires comprennent une pluralité de paires (10b, 100b) de conformations complémentaires mutuellement emboîtables.

8. Le système d'éclairage de l'une des revendications précédentes, dans lequel ledit composant d'éclairage (100) comprend au moins une source statique de rayonnement de lumière (1, 2).

9. Le système d'éclairage de la revendication 8, dans lequel ledit composant d'éclairage (100) comprend au moins une source LED (1, 2).

10. Un procédé d'obtention d'un composant d'éclairage, dans lequel le procédé comprend :

- l'obtention d'un composant d'éclairage allongé (100) comprenant une surface d'émission lumineuse frontale (122) et une surface dorsale opposée à ladite surface frontale, et un élément de fixation (10) pouvant être couplé à une structure de montage (S), le composant d'éclairage (100) comprenant un composant protégé incluant une encapsulation d'étanchéité flexible (122),

- l'obtention sur le composant d'éclairage (100) et l'élément de fixation (10) de conformations complémentaires (10b, 100b) pouvant être mutuellement emboîtées en une relation de couplage des formes, dans lequel :

l'encapsulation d'étanchéité flexible (122) est constituée d'un matériau perméable à la lumière et lesdites conformations complémentaires comprennent au moins une gorge (100b) formée dans ladite encapsulation d'étanchéité

flexible (122) sur ladite surface dorsale du composant d'éclairage (100) et au moins un relief en forme de nervure (10b) dans l'élément de fixation (10), et

- le couplage du composant d'éclairage (100) et de l'élément de fixation (10) par amenée desdites conformations complémentaires (10b, 100b ; 91, 101, 102) en une relation de couplage par les formes.

5

10

**11.** Le procédé de la revendication 10, comprenant le couplage de l'élément de fixation (10) à une structure de montage (S).

**12.** Le procédé de la revendication 11, comprenant le couplage de l'élément de fixation (10) à une structure de montage (S) avant de coupler le dispositif d'éclairage (100) et l'élément de fixation (10).

15

20

25

30

35

40

45

50

55

FIG. 1

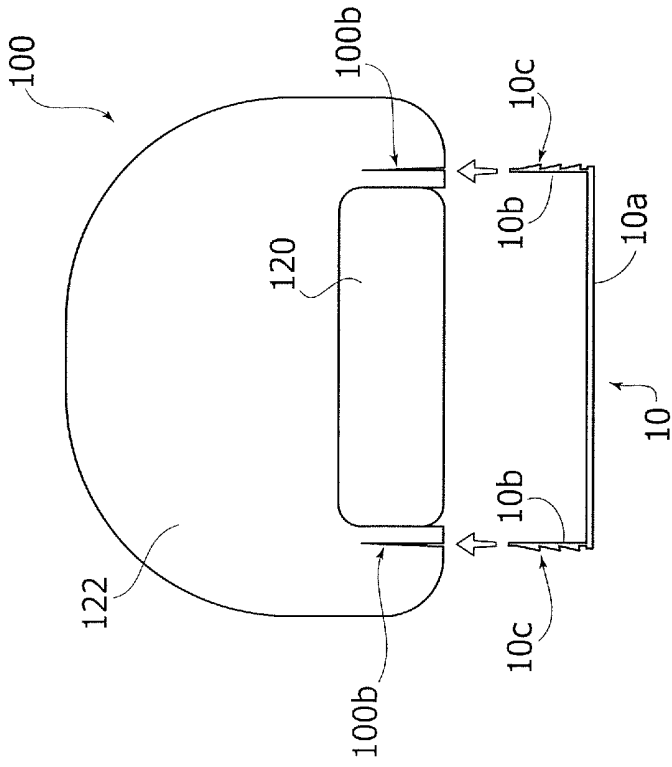

FIG. 2

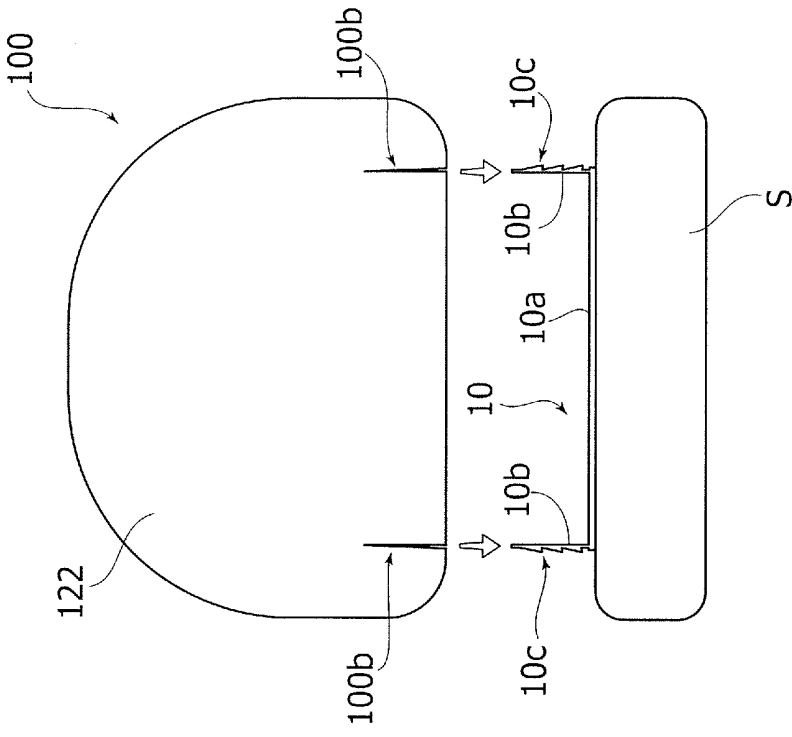

FIG. 3

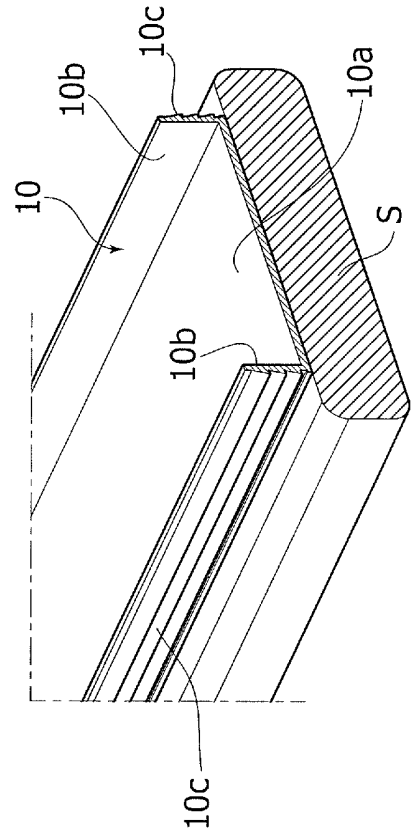

FIG. 4

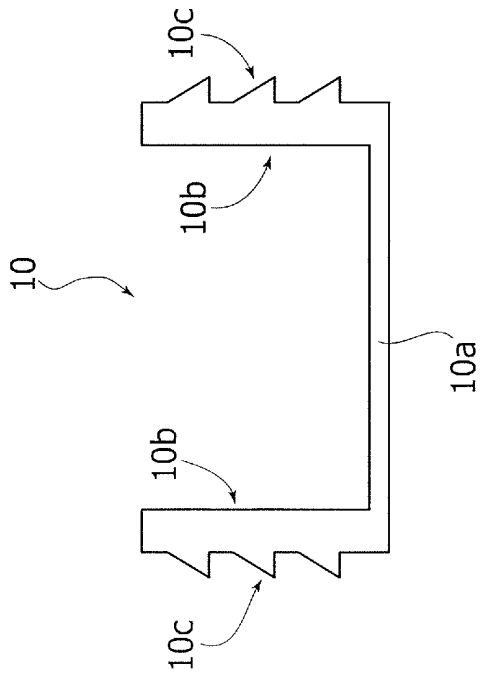

FIG. 5

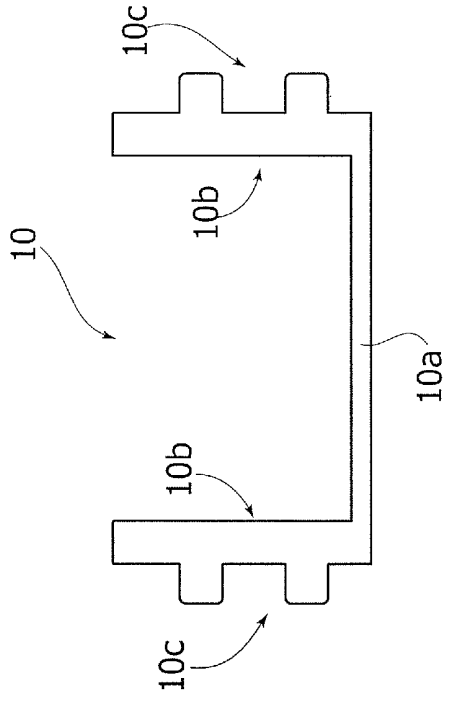
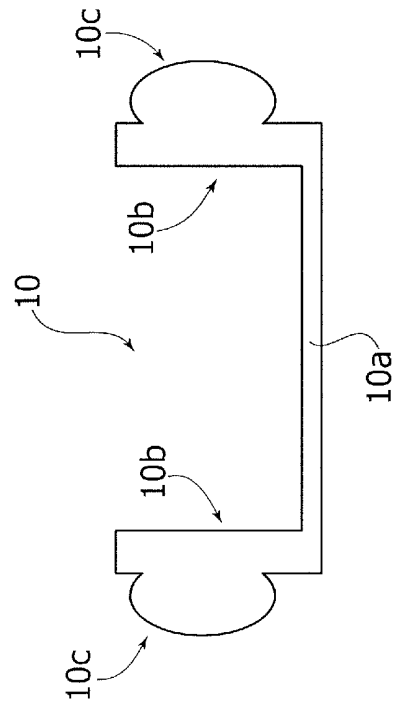
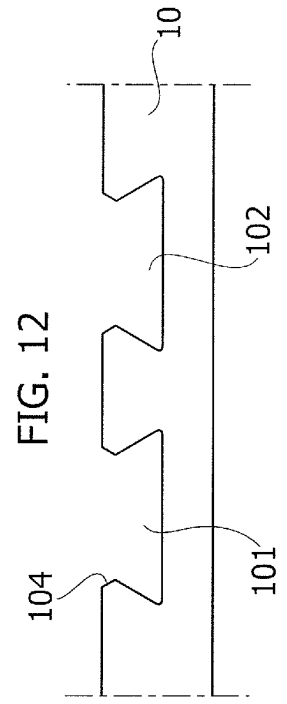
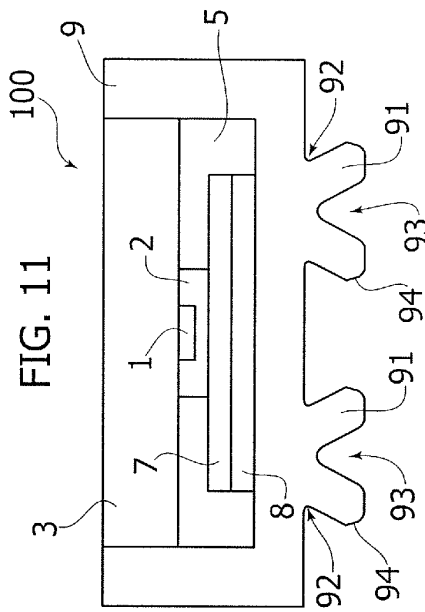
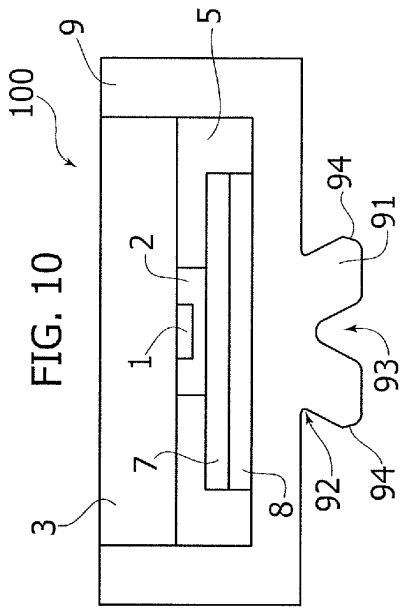
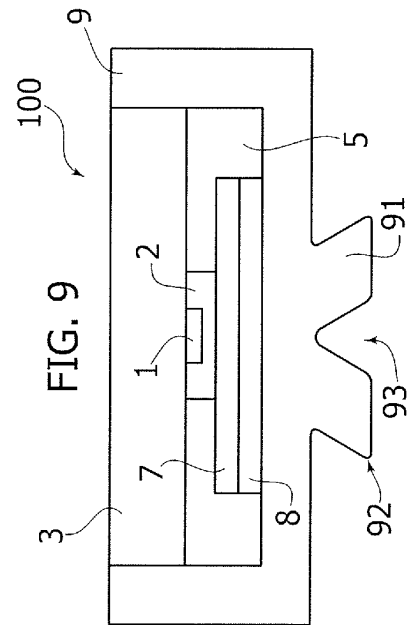
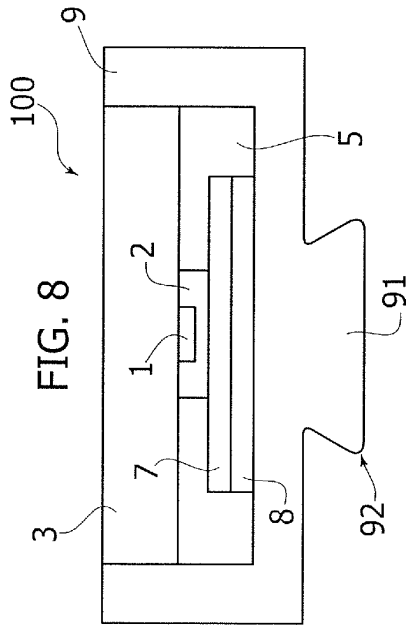
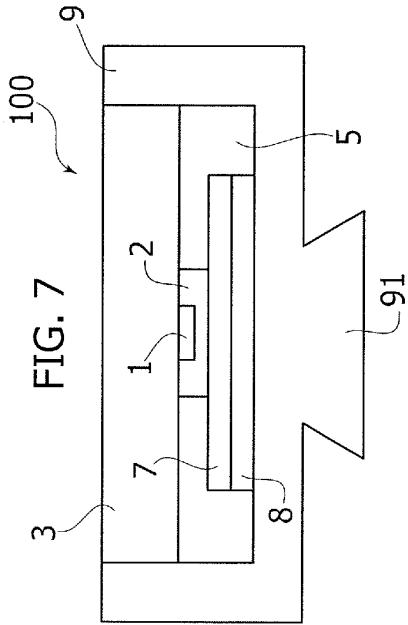
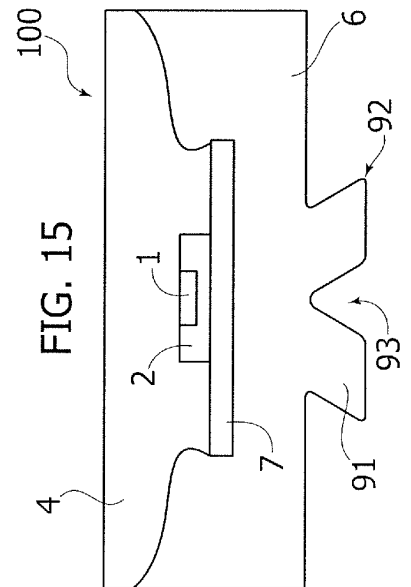
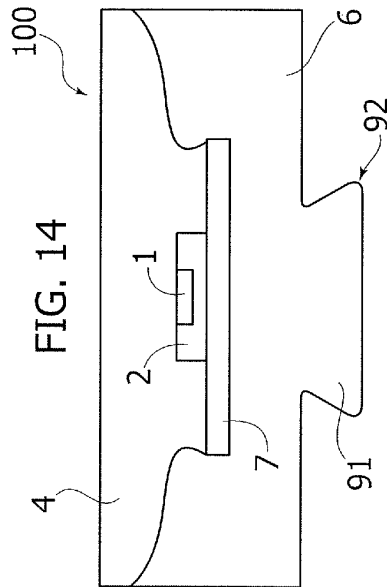
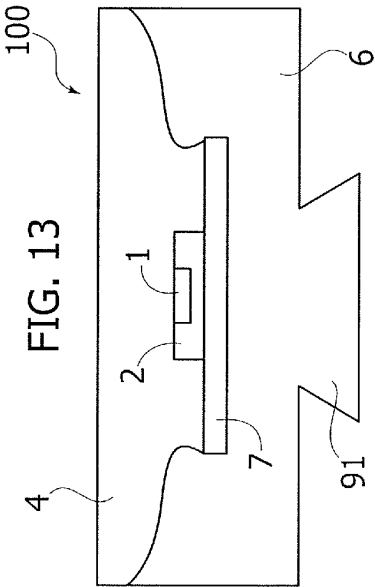
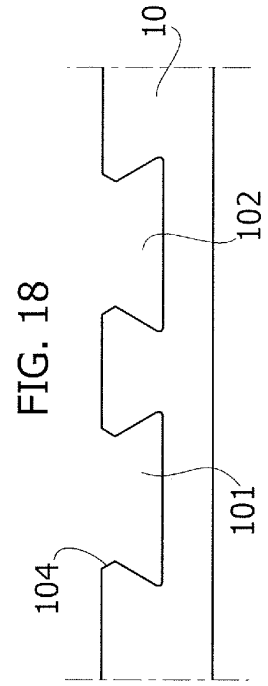
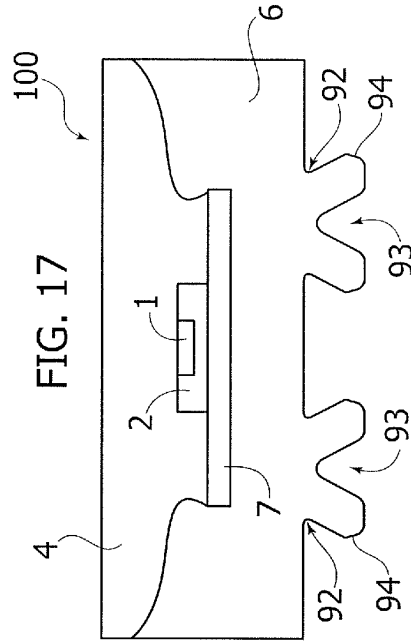
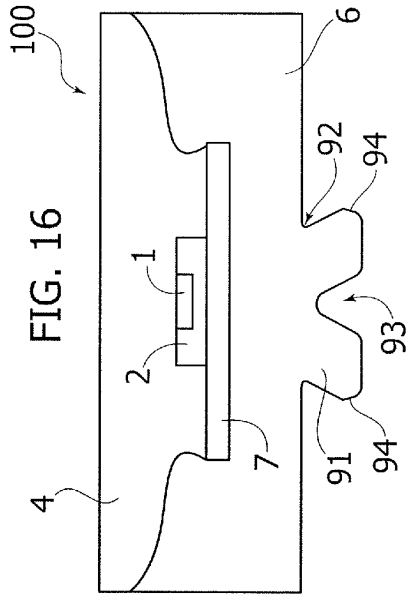

FIG. 6







**REFERENCES CITED IN THE DESCRIPTION**

*This list of references cited by the applicant is for the reader's convenience only. It does not form part of the European patent document. Even though great care has been taken in compiling the references, errors or omissions cannot be excluded and the EPO disclaims all liability in this regard.*

**Patent documents cited in the description**

- US 6186645 B1 [0014]
- EP 0606006 A1 [0015]
- WO 2014313722 A1 [0016]
- WO 2008134424 A2 [0016]
- WO 9906759 A1 [0016]
- US 2010238655 A1 [0016]