



(11) **EP 3 361 166 A1**

(12) **EUROPEAN PATENT APPLICATION**

(43) Date of publication:  
**15.08.2018 Bulletin 2018/33**

(51) Int Cl.:  
**F24F 1/14 (2011.01)** **F24F 1/16 (2011.01)**  
**F24F 1/24 (2011.01)**

(21) Application number: **17155592.3**

(22) Date of filing: **10.02.2017**

(84) Designated Contracting States:  
**AL AT BE BG CH CY CZ DE DK EE ES FI FR GB GR HR HU IE IS IT LI LT LU LV MC MK MT NL NO PL PT RO RS SE SI SK SM TR**  
Designated Extension States:  
**BA ME**  
Designated Validation States:  
**MA MD**

(72) Inventors:  
• **Pirmez, Pieter**  
**8400 Oostende (BE)**  
• **Kawano, Satoshi**  
**8400 Oostende (BE)**  
• **KOJIMA, Akiharu**  
**Osaka-shi**  
**Osaka 530-8323 (JP)**

(71) Applicants:  
• **Daikin Europe N.V.**  
**8400 Oostende (BE)**  
• **Daikin Industries, Ltd.**  
**Osaka-shi, Osaka 530-8323 (JP)**

(74) Representative: **Hoffmann Eitle**  
**Patent- und Rechtsanwälte PartmbB**  
**Arabellastraße 30**  
**81925 München (DE)**

(54) **HEAT SOURCE UNIT AND AIR CONDITIONER HAVING THE HEAT SOURCE UNIT**

(57) Heat source unit (2) for an air conditioner (1) comprising a refrigerant circuit, the heat source unit comprising an external housing (10) accommodating a compressor (3) to be connected to the refrigerant circuit; a heat source heat exchanger (5) to be connected to the refrigerant circuit and configured to exchange heat between a refrigerant circulating in the refrigerant circuit and a heat source (104); an electric box (30) having a top (31) and side walls (32 to 34), the electric box accommodating electrical components (36) to configured to control the air conditioner and having an air passage (37) comprising an air inlet (38) and an air outlet (39), an air flow (41) being induced through the air passage from the air inlet to the air outlet for cooling at least some of the electrical components, wherein a cooling heat exchanger (22) accommodated in the external housing and to be connected to the refrigerant circuit, wherein the cooling heat exchanger (22) is arranged at one of the side walls (32 to 34) of the electric box so as to be blown through by the air flow (41) and exchange heat between the refrigerant and the air flow (41).

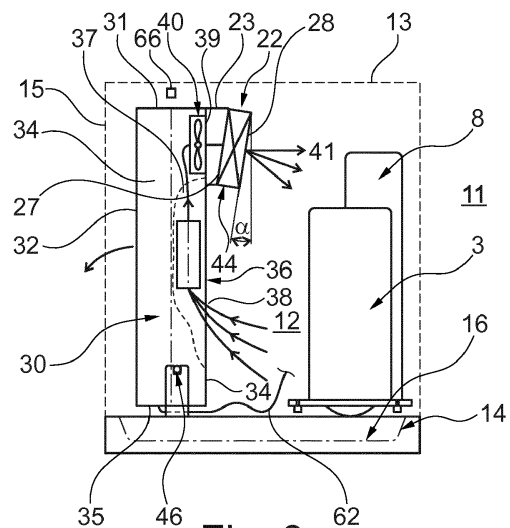

**Fig. 3**

## Description

### Technical field

5 [0001] The present disclosure relates to a heat source unit and an air conditioner having the heat source unit. Air  
 conditioners generally employ a heat pump to cool and/or heat air in one or more rooms to be conditioned. The heat  
 pump generally comprises a refrigerant circuit having at least a compressor, a heat source heat exchanger, an expansion  
 valve and at least one indoor heat exchanger. The heat source unit is to be understood as the unit of the air conditioner  
 10 (heat pump) that comprises the heat source heat exchanger used to transfer heat energy between a source of heat,  
 such as air, ground or water, and a refrigerant flowing in the refrigerant circuit.

### Background

15 [0002] Known heat source units generally comprise an external housing accommodating at least the compressor, the  
 heat source heat exchanger and an electric box accommodating electrical components configured to control the air  
 conditioner, particularly the refrigerant circuit of the heat pump.

[0003] At least some of the electrical components contained in the electric box require cooling. For this purpose JP-  
 A-2016-191505 discloses an electric box having an air passage comprising an air inlet and an air outlet opening into an  
 interior of the external housing and a fan configured to induce an air flow through the air passage from the air inlet to  
 20 the air outlet for cooling the electrical components.

[0004] The electrical components transfer heat to the air flowing in the air passage. The heated air is subsequently  
 introduced into the interior of the external housing. A similar disclosure may be found in US 2016/0258636 A1.

[0005] To support cooling of the electrical components  
 US 2016/0258636 A1 additionally suggests a heat dissipating plate disposed with a first portion in direct contact with  
 25 an electrical component and with a second portion outside the electric box. A refrigerant piping connected to the refrigerant  
 circuit is coupled to the second portion of the heat dissipating plate. It may for maintenance reasons or to make modi-  
 fications of a controller contained in the electric box be required to access the electric box. In the configuration of US  
 2016/0258636 A1 the refrigerant piping has to be disassembled from the second portion of the heat dissipating plate.  
 Due to the fragility of the refrigerant piping, there is a risk of damaging the refrigerant piping.

30 [0006] In addition, hot refrigerant components such as the compressor, a liquid receiver or an oil separator accom-  
 modated in the external housing of the heat source unit dissipate heat as well.

[0007] The heat source unit is under certain circumstances disposed in an installation environment or space, such as  
 installation rooms inside a building. This is particularly the case when using water as the source of heat. Because the  
 heat source unit as a whole dissipates heat, the temperature in the installation room may increase, which is perceived  
 35 disadvantageous. If other equipment is also installed in the installation room and the other equipment is sensible to high  
 temperatures, even additional cooling of the installation room may be required.

### Summary

40 [0008] In view of the aforesaid, it is an object to provide a heat source unit for an air conditioner and an air conditioner  
 having such a heat source unit in which an amount of heat dissipated by the heat source unit can be reduced or even  
 be eliminated.

[0009] A basic idea to address this problem is the provision of a cooling heat exchanger to be connected to the  
 refrigerant circuit of the air conditioner and flown through by a refrigerant. The cooling heat exchanger is arranged so  
 45 as to be flown through by the air flow induced through the air passage of the electric box, whereby the air is cooled. As  
 a result, an amount of heat dissipated by the heat source unit, particularly the air expelled from the electric box after  
 cooling the electrical components, can be reduced or even be eliminated. Yet, there is a certain risk that condensation  
 water, which is formed on the cooling heat exchanger due to the temperature difference and humidity in the air, comes  
 into contact with the electrical components. Thus, a further object may be to provide a heat source unit and an air  
 50 conditioner having such a heat source unit in which the risk of condensation water coming into contact with electrical  
 components of the electric box is minimized.

[0010] Moreover, it may be an aim to provide a heat source unit for an air conditioner and an air conditioner having  
 such a heat source unit in which a cooling heat exchanger to cool the air flowing through the air passage of the electric  
 box recovers the heat dissipated from the electrical components and uses the heat in the refrigerant circuit of the air  
 55 conditioner. In this connection, it would be beneficial if the cooling heat exchanger is arranged in the refrigerant circuit  
 so as to enable heat recovery at the same time minimizing any negative effects on a possible capacity and operation of  
 the air conditioner. Further, a simple control mechanism for controlling the refrigerant flow through the cooling heat  
 exchanger is desired to minimize costs.

**[0011]** An even further object may be to provide a heat source unit for an air conditioner and an air conditioner having such a heat source unit in which access to the electric box is simplified for ease of maintenance.

**[0012]** According to an aspect and for solving at least one of the above objects, a heat source unit as defined in claim 1 is suggested. Further embodiments including an air conditioner having such a heat source unit are defined in the dependent claims, the following description and the drawings.

**[0013]** In accordance with one aspect, a heat source unit for an air conditioner is suggested. In general, the air conditioner may be operated in a cooling operation for cooling a room (or a plurality of rooms) to be conditioned and optionally in heating operation for heating a room (or a plurality of rooms) to be conditioned. If the air conditioner is configured for more than one room even a mixed operation is conceivable in which one room to be conditioned is cooled whereas another room to be conditioned is heated. The suggested air conditioner comprises a refrigerant circuit. As previously indicated the refrigerant circuit may constitute a heat pump and comprise at least a compressor, a heat source heat exchanger, an expansion valve and at least one indoor heat exchanger. The heat source unit according to one aspect comprises an external housing defining an interior of the heat source unit and an exterior of the heat source unit. The external housing accommodates at least the compressor, the heat source heat exchanger, an electric box and a cooling heat exchanger. The cooling heat exchanger may function as an evaporator in the refrigerant circuit and may, hence, also be referred to as an evaporator. The external housing may further accommodate an expansion valve, a liquid receiver, an oil separator and an accumulator of the refrigerant circuit.

**[0014]** The components of the refrigerant circuit accommodated in the external housing, particularly the compressor and the heat source heat exchanger are to be connected to the refrigerant circuit. Further, the heat source heat exchanger is configured to exchange heat between a refrigerant circulating in the refrigerant circuit and a heat source, particularly water even though air and ground are as well conceivable. The electric box accommodates electrical components which are configured to control the air conditioner, particularly the heat pump. The electric box has at least a top and side walls. A bottom end of the electric box may either be open or has a bottom. The side walls extend in general along a vertical direction from the bottom to the top. "Along the vertical direction" in this context does not require that the side walls are oriented vertical even though this is one possibility. Rather, the side walls may also be inclined to the vertical direction. As long as the side walls are not angled more than 45° to a vertical direction, the side walls are to be understood as extending along the vertical direction. In order to enable cooling of at least some of the electrical components contained in the electric box, an air passage comprising an air inlet and an air outlet is suggested. According to an aspect at least the air outlet is arranged in the electric box so as to open into the interior of the external housing. This is particularly preferred if also hot refrigerant components accommodated in the external housing are to be cooled as will be described later. Yet, it is also conceivable that the air outlet opens to the external of the external housing. The air inlet may either be arranged so as to open to the exterior of the external housing or into the interior of the external housing. An air flow through the air passage from the air inlet to the air outlet may be induced by natural convection. Alternatively, a fan may be provided either at the air inlet or the air outlet to induce the air flow as described later. A cooling heat exchanger to be connected to the refrigerant circuit of the air conditioner is suggested so as to minimize the amount of heat from the electrical components being dissipated into the surroundings of the heat source unit. The cooling heat exchanger is arranged at one of the side walls of the electric box so as to be flown through by the air flow and exchange heat between the refrigerant and the air flow.

**[0015]** Accordingly, in one case the air introduced through the air inlet may be cooled by heat transfer between the air and the refrigerant flowing through the cooling heat exchanger, whereby the temperature of the refrigerant is increased and at least some of the refrigerant evaporates. Accordingly the temperature of the air flowing into the air passage through the air inlet is lower than the temperature of the air in the interior of the external housing or the environment of the heat source unit. Thus, the air expelled through the air outlet may have a temperature similar to that of the air in the external housing or the environment of the heat source unit. As a result, the electrical components do not further heat up the interior of the external housing and the amount of heat dissipated to the exterior (environment) can be reduced. In addition, disposing the cooling heat exchanger at the side walls of the electric box enables efficient use of a large heat exchange surface of the cooling heat exchanger without the need of increasing the width and/or the height of the electric box for fixing the cooling heat exchanger. Thus, this arrangement makes beneficial use of the available mounting space. In addition, arranging the cooling heat exchanger at a side wall of the electric box assists preventing any condensation water from coming into contact with the electrical components in the air passage.

**[0016]** If the cooling heat exchanger is disposed upstream of the electrical components in the air passage it is conceivable that sweat is generated on the inside of the electric box because of the relatively cool air introduced into the air passage and the high temperature difference between the air passage and the electric box. To prevent the formation of sweat, the cooling heat exchanger may be disposed downstream of the electrical components to be cooled in the direction of the air flow. According to one aspect, the cooling heat exchanger may be disposed at the air outlet of the air passage. Accordingly, the air flowing into the air inlet from the interior of the external housing flows through the air passage and cools the electrical components in the air passage, whereby the temperature of the air increases. Subsequently, the air is cooled by flowing through the cooling heat exchanger, wherein the temperature of the refrigerant

flowing through the cooling heat exchanger is increased and the refrigerant evaporates. The air expelled from an air outlet of the cooling heat exchanger has than a temperature which is at least similar if not the same as the temperature of air in the interior of the external housing and may even be lower. Hence, also in this case the electrical components do not further heat up the air in the interior of the external casing and hence heat dissipation to the exterior surroundings may be reduced. Furthermore, there is a risk that condensation water is formed on the surfaces of the cooling heat exchanger as explained earlier. Because the cooling heat exchanger is arranged downstream of electrical components of the electrical components and/or a heat sink heat conductively connected to electrical components of the electrical components which are disposed in the air flow, i.e. in the air passage, the risk is reduced that condensation water will come in contact with the electrical components or the heat sink. In particular, as the air flow is away from the electrical components and the heat sink in the air passage, the air flow will rather transport any condensation water away from the electrical components and the heat sink. Moreover, disposing the cooling heat exchanger downstream of the electrical components to be cooled has the advantage that a larger amount of heat may be transferred to the refrigerant so that heat recovery and the use of heat in the refrigerant circuit are improved.

**[0017]** As previously mentioned, it is conceivable to provide at least one fan to induce the air flow through the air passage from the air inlet to the air outlet. Accordingly, efficiency of cooling of the electrical components and the heat transfer between the air flow and the refrigerant in the cooling heat exchanger may be enhanced because a larger air flow may be generated as compared to natural convection.

**[0018]** According to an aspect, the fan is disposed at the air outlet. This has the advantage that maintenance of the fan is simplified, because the fan is easily accessible even from the outside of the electric box.

**[0019]** To even further improve the effect of preventing condensation water coming in contact with the electrical components and the heat sink, it may be advantageous to dispose the cooling heat exchanger downstream of the fan. Hence a relatively large air flow "blows" any condensation water on the cooling heat exchanger away from the air passage and the air outlet. Moreover, the fan can then form a barrier between the electrical components and the air passage and the cooling heat exchanger further preventing any condensation water from entering the air passage. A further advantage of this configuration may be that the efficiency of the fan is higher if it is disposed upstream of the cooling heat exchanger so that less power is required to drive the fan.

**[0020]** As indicated in the introductory portion, also other components of the refrigerant circuit (heat pump) are accommodated in the external housing dissipating heat because of hot refrigerant flowing through the components in use. One example of such a hot refrigerant component is the compressor. Other examples are an oil separator or a liquid receiver. In order to decrease the amount of heat dissipated from these components to the exterior of the heat source unit, the cooling heat exchanger may be oriented and particularly an air outlet of the cooling heat exchanger may be oriented or configured to expel the air leaving the cooling heat exchanger in a direction of hot refrigerant components accommodated in the external housing comprising at least one of the group consisting of the compressor, an oil separator and a liquid receiver. In one particular example, the cooling heat exchanger may have a duct connecting at one end to the air outlet of the air passage and at an opposite end to an air inlet of the cooling heat exchanger. The duct may form a passage changing the direction of the air flow from the air outlet of the electric box to the air inlet of the cooling heat exchanger. Thus, common plate-shaped heat exchangers may be used as cooling heat exchanger. The change of the flow direction is then achieved by the duct and the common plate - shaped heat exchanger is attached in an inclined orientation relative to the vertical direction to the duct, whereby the air outlet of the heat exchanger (cooling heat exchanger) is directed to the direction of the hot refrigerant components, whereby the air flow is directed on and cools the hot refrigerant components within the external housing. As a consequence, the heat dissipated from the hot refrigerant components to the interior of the external housing and, hence, the environment of the heat source unit can be reduced even further.

**[0021]** According to further aspect, the air outlet of the air passage is located closer to a top than to a bottom of the external housing. In a particular embodiment, the air outlet of the air passage is located closer to the top than to a bottom end of the electric box. The above arrangement provides for the beneficial effect that natural convection within the interior of the external housing is promoted because relatively cool air is expelled from the air outlet of the air passage at a relatively high position within the external housing which because of natural convection than automatically flows down to the bottom of the external housing.

**[0022]** According to another aspect, the cooling heat exchanger may be connected to a bypass line branched from a liquid refrigerant line and a gas suction line. "Liquid refrigerant line" is in this context to be understood as a line of the refrigerant circuit in which the flowing refrigerant is in the liquid phase. "Gas suction line" is in this context to be understood as a line of the refrigerant circuit on a suction side of the compressor in which gaseous refrigerant flows. According to an example, the liquid refrigerant line is a line connecting the heat source heat exchanger and the indoor heat exchanger. Furthermore, the bypass line may be connected to the liquid refrigerant line in this example with an expansion valve interposed between the bypass line and the heat source heat exchanger. In one particular example, the gas suction line may be a line connected to a suction side of the compressor with one or more components, such as an accumulator, that may be interposed. To put it differently, the cooling heat exchanger is connected to a bypass line branched from a

liquid refrigerant line, e.g. connected to the heat source heat exchanger, and a gas suction line, e.g. connected to a suction side of the compressor. Yet, it is also conceivable that an accumulator is disposed between the connection of the bypass line to the gas suction line and the suction side of the compressor. The benefit of this aspect is that the cooling heat exchanger may always be operated as long as the compressor is operating so that a reliable system is obtained without negatively affecting the refrigerant circuit of the air conditioner. In addition, this arrangement provides for an efficient use of the heat dissipated from the electrical components in the refrigerant circuit during heating operation of the air conditioner.

[0023] The bypass line may have an expansion valve, wherein the opening degree of the expansion valve is controllable. Yet, according to an embodiment, the bypass line may have a valve and a capillary both upstream of the cooling heat exchanger. According to one embodiment, the valve is switched ON/OFF only, that is the valve is (completely) opened/closed only. The valve may be a solenoid valve. The use of a controlled expansion valve enables a more sophisticated control. Yet, this is not under all circumstances necessary with respect to the cooling heat exchanger flow through by the air flow. Thus, the use of a valve and a capillary instead of the expansion valve provides for a simpler configuration, which is less costly and can dispense the more complicated control logic necessary when using an expansion valve. In either case, it is possible to adapt the cooling performance of the cooling heat exchanger on the needs of the system and the circumstances such as operation conditions of the air conditioner.

[0024] As previously indicated, there is a certain risk that condensation water is accumulated on the surfaces of the cooling heat exchanger. According to an aspect, a bottom end portion of the cooling heat exchanger slopes downward towards an air outlet of the cooling heat exchanger. For example, the cooling heat exchanger may have a bottom plate being arranged so as to slope downward towards the air outlet of the cooling heat exchanger. Accordingly, any condensation water which drops or flows down from the cooling heat exchanger will be guided by the bottom end portion, e.g. the bottom plate, from an air inlet of the cooling heat exchanger to an air outlet of the cooling heat exchanger, at which position the condensation water may drop down into a drain pan accommodated in the external housing. Thus, any condensation water is guided away from the air inlet of the cooling heat exchanger. As a result, it can surely be prevented that any condensation water will flow into the air passage and come in contact with the electrical components or the heat sink.

[0025] According to an aspect the cooling heat exchanger has a plurality of fins and tubes, wherein the fins are arranged with a longitudinal extension along a vertical direction. The fins are in principle plate shaped having a length and a width much larger than a height. Thus, the length and the width define a main surface of the fins. The tubes generally extend perpendicular to the main surfaces of the fins. "Along a vertical direction" is, in this context, to be understood in the same manner as explained with respect to the side walls above. In particular, the fins do not need to be oriented vertical but merely need to extend in a direction from a bottom to a top of the external housing. In one example, the fins are with a longitudinal extension inclined relative to the vertical direction. This is particularly the case, if the cooling heat exchanger is inclined to expel the air toward the hot refrigerant components in the external housing as described above. Due to the orientation of the fins along a vertical direction, any condensation water flows along the fins from a top end portion to the bottom end portion of the cooling heat exchanger. Particularly in combination with the bottom end portion sloping downward toward the air outlet of the air conditioner, this ensures that all condensation water of the cooling heat exchanger is guided away from the air passage.

[0026] A further aspect concerns an air conditioner having a heat source unit according to any aspect as described above. The heat source unit is connected to at least one indoor unit having an indoor heat exchanger forming the refrigerant circuit. As previously indicated, the air conditioner has the refrigerant circuit which may constitute a heat pump. Hence, the refrigerant circuit may comprise the compressor, the heat source heat exchanger, an expansion valve and at least one indoor heat exchanger to form a heat pump circuit. Additional components as known for air conditioners may be included as well such as a liquid receiver, an accumulator and an oil separator. According to one aspect, the air conditioner uses water as a heat source. According to a further aspect, the air conditioner is mounted in a building comprising one or more rooms to be conditioned and the heat source unit is installed in an installation environment or space, such as an installation room of the building.

[0027] Further aspects, features and advantages may be found in the following description of particular examples. This description refers to the accompanying drawings.

### Brief description of drawings

[0028] The drawings show in:

Figure 1: an example of an air conditioner installed in an office building.

Figure 2: a schematic circuit diagram of a simplified air conditioner.

Figure 3: a schematic side view of a heat source unit with the side walls and the top of the external housing being removed.

Figure 4: an overall perspective view of a heat source unit.

Figure 5: a perspective view of the heat source unit of figure 4 with a maintenance plate of the external housing being removed.

Figure 6: a side view of the heat source unit of figure 4 with the side walls and the top of the external housing being removed.

Figure 7: a perspective view of the heat source unit of figure 4 with the side walls and the top of the external housing being removed.

Figure 8: a top view of the heat source unit of figure 4 with the side walls and the top of the external housing being removed.

Figure 9: a perspective view of the heat source unit of figure 4 with the side walls and the top of the external housing and the electric box being removed.

Figure 10: a graph showing a control mechanism according to an example.

#### Description of a particular embodiment

**[0029]** In the following description and the drawings, the same reference numerals have been used for the same elements and repetition of the description of these elements in the different embodiments is omitted.

**[0030]** Figure 1 shows an example of an air conditioner 1 installed in an office building. The office building has a plurality of rooms 105 to be conditioned such as conference rooms, a reception area and working places of the employees.

**[0031]** The air conditioner 1 comprises a plurality of indoor units 100 to 102. The indoor units are disposed in the rooms 105 and may have different configurations, such as wall-mounted 102, ceiling mounted 101 or duct-type indoor units 100.

**[0032]** The air conditioner further comprises a plurality of heat source units 2. The heat source units 2 are installed in an installation room 29 of the office building. Other equipment such as servers (not shown) may be installed in the installation room 29 as well. In the present example, the heat source units 2 use water as heat source. In the particular example, a water circuit 104 is provided which is connected to a boiler, dry-cooler, cooling tower, ground loop or the like. The water circuit 104 may as well have a heat pump circuit including a refrigerant circuit. An outdoor unit comprising the heat source heat exchanger of this heat pump circuit may be disposed on the roof of the office building and use air as the heat source. Yet, the concept of the heat source unit of the present disclosure is also applicable to other heat sources such as air or ground.

**[0033]** In operation one or more of the indoor units 100 to 102 may be operated to cool the respective rooms 105 whereas others are operated to heat the respective rooms.

**[0034]** A simplified schematic diagram of the air conditioner is shown in figure 2. The air conditioner 1 in figure 2 is mainly constituted by an indoor unit 100 and the heat source unit 2. Yet, the air conditioner 1 in figure 2 may also have a plurality of indoor units 100. The indoor units may have any configuration such as those described with respect to figure 1 above.

**[0035]** Further, figure 2 shows the refrigerant circuit constituting a heat pump. The refrigerant circuit comprises a compressor 3, a 4-way valve 4 for switching between cooling and heating operation, a heat source heat exchanger 5, an expansion valve 6, and optional additional expansion valve 7 and an indoor heat exchanger 103. The heat source heat exchanger 5 is additionally connected to the water circuit 104 as the heat source. When the compressor 3 is operated, a refrigerant is circulated in the refrigerant circuit.

**[0036]** In cooling operation, high-pressure refrigerant is discharged from the compressor 3, flows through the 4-way valve 4 to the heat source heat exchanger 5 functioning as a condenser whereby the refrigerant temperature is decreased and gaseous refrigerant condensed. Thus, heat is transferred from the refrigerant to the water in the water circuit 104. Subsequently, the refrigerant passes the expansion valve 6 and the optional expansion valve 7, wherein the refrigerant is expanded before being introduced into the indoor heat exchanger 103 functioning as an evaporator. In the indoor heat exchanger 103, the refrigerant is evaporated and heat is extracted from the air in the room 105 to be conditioned, whereby the air is cooled and reintroduced into the room 105. At the same time, the temperature of the refrigerant is increased. Subsequently, the refrigerant passes the 4-way valve 4 and is introduced into the compressor 3 as low-pressure gaseous

refrigerant at the suction side of the compressor 3. In view of the aforesaid, the line connecting the heat source heat exchanger 5 and the indoor heat exchanger 103 is considered a liquid refrigerant line 25. The line connecting the 4-way valve 4 and the suction side of the compressor 3 is considered a gas suction line 26.

[0037] In heating operation, high-pressure refrigerant is discharged from the compressor 3, flows through the 4-way valve 4 to the indoor heat exchanger 103 (dotted line of the 4 way valve 4) functioning as the condenser, whereby the refrigerant temperature is decreased and gaseous refrigerant condensed. Thus, heat is transferred from the refrigerant to the air in the room 105 whereby the room is heated. Subsequently, the refrigerant passes the optional expansion valve 7 and the expansion valve 6, wherein the refrigerant is expanded before being introduced into the heat source heat exchanger 5 functioning as an evaporator via the liquid refrigerant line 25. In the heat source heat exchanger 5, the refrigerant is evaporated and heat is extracted from water in the water circuit 104. At the same time, the temperature of the refrigerant is increased. Subsequently, the refrigerant passes the 4-way valve 4 (dotted line of the 4-way valve 4) and is introduced into the compressor 3 as low-pressure gaseous refrigerant at the suction side of the compressor 3 via the gas suction line 26.

[0038] The refrigerant circuit shown in figure 2 further comprises a bypass line 24 branched from the liquid refrigerant line 25 and connected to the gas suction line 26. In the particular example, the bypass line 24 is connected to the liquid refrigerant line 25 between the expansion valve 6 and the indoor heat exchanger 103. If the optional expansion valve 7 is provided, the bypass line 24 is connected between the expansion valve 6 and the optional expansion valve 7.

[0039] The bypass line 24 comprises a valve 20 which may assume an open and a closed position (ON/OFF). The valve 20 may be a solenoid valve. Furthermore, the bypass line 24 comprises a capillary 21. In the particular example, the capillary 21 is disposed downstream of the valve 20 in the direction of the flow of refrigerant during cooling operation. Yet, the valve 20 may as well be disposed downstream of the capillary 21.

[0040] Furthermore, a cooling heat exchanger 22 (described in more detail below) is connected to the bypass line 24 downstream of the capillary 21 and the valve 20 in the direction of flow of refrigerant during cooling operation. The function of this cooling heat exchanger 22, the valve 20 and the capillary 21 will be described further below.

[0041] In one example, the components contained in the dotted rectangle indicating the heat source unit 2 in figure 2 are accommodated in an external housing 10 (see figure 4) of the heat source unit 2.

[0042] As schematically indicated in figure 3 and shown in more detail in figures 4 to 9, the external housing 10 has side walls 15 and a top 13 both shown in a dotted lines. Furthermore, the external housing 10 has a bottom 14. Thus, the external housing 10 defines an interior 12 of the external housing 10 and an exterior 11 of the external housing 10 which in one example may be the installation room 29 as an example of an installation environment or installation space (see figure 1). In the present example, the bottom 14 has a drain pan 16 for collecting any condensation water accumulated in the external housing 10. The bottom 14 supports the remaining components of the heat source unit 2 to be explained in the following. According to one example, none of the components contained in the external housing 10 is fixed to the side walls 15 or the top 13, but all components are directly or indirectly, via the support structures, fixed to the bottom 14.

[0043] As an example, the compressor 3, and a liquid receiver 8 commonly used in refrigerant circuits of air conditioners are shown as a components accommodated in the external housing 10. Further components are an oil separator 9 and an accumulator 108 (see Fig. 7). In this context, the compressor 3, the liquid receiver 8 and the oil separator 9 are considered as hot refrigerant components, because at least a proportion of the refrigerant passing through these components is gaseous and hot. The accumulator 108 in contrast is considered as a cold refrigerant component as only low pressure refrigerant passes through the accumulator 108.

[0044] The external housing 10 may have vents 16 to allow ventilation of the interior 12 in case the later described zero heat dissipation control is not active.

[0045] Furthermore, the heat source unit 2 comprises an electric box 30. The electric box 30 has the shape of a parallelepiped casing, but other shapes are conceivable as well. In the example, the electric box 30 has a top 31, the side walls (in the present example four side walls, namely a back 32, a front 33 and two opposite sides 34) and a bottom 35. In other embodiments, the bottom may be open. The electric box 30 has a height between the bottom end 35 and the top 31, a depth between the back 32 and the front 33 and a width between the two opposite sides 34. In the present embodiment, the electric box 30 is longitudinal having a height larger (at least twice as large) than the depth and the width.

[0046] The electric box 30 accommodates a plurality of electrical components 36 configured to control the air conditioner and particularly its components such as the compressor 3, the expansion valves 6 and 7 or the valve 20. The electrical components 36 are schematically shown in figure 3 only.

[0047] The electric box 30 further defines an air passage 37 having an air inlet 38 and an air outlet 39. In the present embodiment, the air inlet 38 is disposed closer to the bottom 35 or the bottom end of the electric box 30 than the air outlet 39. Even more particular, the air outlet 39 is located adjacent to the top 31 of the electric box 30. Due to the longitudinal configuration of the electric box 30 and its orientation with respect to the longitudinal extension along a vertical direction, the air outlet 39 is located adjacent to a top 13 of the external housing 10 (closer to the top 13 than to the bottom 14). In addition, both the air inlet 38 and the air outlet 39 open into the interior 12 of the external housing 10.

[0048] The electrical components 36, which require cooling, are either directly disposed in the air passage 37 as shown

in figure 3 and/or a heat sink is provided which is heat conductively connected to electrical components to be cooled and the heat sink is directly disposed in the air passage 37.

5 [0049] Furthermore, the present embodiment shows a fan 40 to induce an air flow 41 (arrows in figure 3) from the air inlet 38 to the air outlet 39 through the air passage 37. Accordingly, the air passes the electrical components 36 for cooling, wherein heat is transferred from the electrical components either directly or via the mentioned heat sink to the air flowing through the air passage 37. Certainly, also more than one fan 40 may be provided.

10 [0050] In the present embodiment, the fan 40 is arranged at the air outlet 39 of the air passage so that air from the interior 12 of the external housing 10 is sucked into the air inlet 38 passes through the air passage 37 and is expelled to the interior 12 of the external housing adjacent to the top 13 of the external housing 10. Accordingly, natural convection is assisted in that relatively cool air is expelled at the top and will naturally flow down towards the bottom 14.

15 [0051] Furthermore and as shown in figures 3, and 6 to 9, the cooling heat exchanger 22 is arranged downstream of the electrical components 36 as seen in the direction of the air flow 41. In the particular example, the cooling heat exchanger 22 is also disposed at the air outlet 39 of the air passage 37 and even downstream of the fan 40 in the direction of the air flow 41. In one example, the cooling heat exchanger 22 is attached to the air outlet 39 via a duct 23. The duct 23 forms an air passage between the air outlet 39 of the air passage 37 and an air inlet 27 of the cooling heat exchanger 22. The duct 23 can be used to change the direction of the air flow 41 and/or to mount a commonly known parallelepiped heat exchanger has the cooling heat exchanger 22 in an angled fashion as will be described later.

20 [0052] As may be best seen in figure 7, the cooling heat exchanger 22 has a plurality of tubes 43 curved at end portions of the cooling heat exchanger 22 and passing a plurality of fins 42 schematically indicated in figure 7. The fins 42 are longitudinal, plate shaped and extend with their longitudinal extension along a vertical direction, i.e. between the bottom 14 and the top 13. It is to be understood, that extending along a vertical direction is as long realized as a longitudinal centerline of the fins 42 in a side view as in figure 3 does not intersect a vertical line at an angle of more than 45°. The fins 42 are flat and have a longitudinal extension (lengths) and widths much larger than the height, whereby a main surface of the fins 42 is defined by the length and the width.

25 [0053] In the particular example, the cooling heat exchanger 22, and particularly the longitudinal direction of the fins 42, is angled by an angle  $\alpha$  (see figure 3) relative to the vertical direction. Accordingly, an air outlet 28 of the cooling heat exchanger is oriented such that the air flow 41 is directed toward hot refrigerant components, in the present example the compressor 3, the liquid receiver 8 as well as an oil separator 9 (see figure 8). The angle  $\alpha$  may be in a range between 0° and 25°. As a result, the air cooled by the cooling heat exchanger 22 and expelled from the air outlet 28 of the cooling heat exchanger 22 is also used to cool one or more of the hot refrigerant components. Consequently, the amount of heat dissipated by the heat source unit 2 as such can be reduced.

30 [0054] Moreover, the cooling heat exchanger 22 has a bottom end portion 44 such as a bottom plate. In the present embodiment, the bottom end portion 44 is downwardly inclined from the air inlet 27 of the cooling heat exchanger 22 towards the air outlet 28 of the cooling heat exchanger 22. In other words the bottom end portion 44 slopes downward towards a bottom 14 of the external housing 10.

35 [0055] As indicated in the introductory portion, there is a risk that condensation water forms on the cooling heat exchanger 22 because of the humidity in the air in the interior 12 of the external housing 10 and the temperature difference. Yet, the particular example provides several means for guiding any condensation water away from the air outlet 39 of the air passage 37 so as to prevent any water from coming into contact with the electrical components 36 or the heat sink in the air passage 37.

40 [0056] On the one hand and as mentioned above, the fins 42 are oriented with their longitudinal direction along a vertical direction. Accordingly, any condensation water formed on the main surfaces of the fins 42 flows down along the fins 42 and, hence, in a vertical direction due to gravity. On the other hand, the bottom end portion 44 of the cooling heat exchanger 22 is downwardly inclined. Accordingly, any condensation water which has flown down the fins 42 and reaches the bottom end portion 44 is guided by the bottom end portion 44 to the air outlet 28 of the cooling heat exchanger 22. At a front edge of the air outlet 28 of the cooling heat exchanger 22, the condensation water may drop down into the drain pan 16 in the bottom 14 of the external housing 10. Thus, any condensation water is securely guided away from the air outlet 39 of the air passage 37.

45 [0057] In addition and as previously mentioned, the cooling heat exchanger 22 is arranged at the air outlet 39 of the air passage 37 and consequently downstream of the electrical components 36 or the heat sink disposed in the air passage 37 in the direction of the air flow 41. Accordingly, the air flow 41 "blows" any condensation water formed on the cooling heat exchanger 22 in a direction away from the air outlet 39 and the electrical components 36. This configuration also assists preventing condensation water from coming into contact with sensible parts of the electric box 30.

50 [0058] Even further, the fan 40 is disposed between the cooling heat exchanger 22 and to the electrical components 36 in the air passage 37. Accordingly, the fan 40 can be considered as a partition separating the cooling heat exchanger 22 from the air passage 37. Hence, the fan 40 is an additional barrier for condensation water and prevents the condensation water from entering the air passage 37.

55 [0059] The electric box 30 is, in the present embodiment, supported so as to be rotatable about an axis of rotation 46.

The support structure 45 is shown in more detail in figures 6 to 9. Thus, the electric box 30 is hinged to the support structure 45 so as to be movable between a use position shown in figure 3 and a maintenance position in which the electric box 30 is tilted about the axis of rotation 46 in a counterclockwise direction shown by the arrow in figure 3 and 6. The axis of rotation 46 is located at a first end of the electric box close to the bottom 35, i.e. opposite to the top 31. Furthermore, the electric box 30 is at the top 31 releasably fixed to the support structure to retain the electric box 30 in the use position by bolts 57 (see figure 5).

**[0060]** In the embodiment shown in figures 6 to 9, the support structure 45 (best visible from figure 9) is formed by a frame 47. The frame 47 is fixed to the bottom 14 of the external housing 10. The frame 47 has two upright columns 48. The columns 48 are mounted to the bottom 14 of the external housing 10.

**[0061]** Each of the columns 48 has at its bottom end close to the bottom 14 of the external housing 10 a slot 49. A boss 50 is provided on either side 34 of the electric box 30 and engaged with one of the slots 49. Different to the schematic view in figure 3, the detailed representation of the slot 49 in figures 6 and 7 shows an inserting portion 51 used to insert the boss 50 into the slot 49 or to remove the boss 50 from the slot 49 and, hence, to completely remove the electric box 30 from the heat source unit 2. The inserting portion 51 has an opening 52 at one end for introducing the boss 50. Furthermore, an engagement portion 53 is formed at the opposite end of the inserting portion 51. The engagement portion has a lower section 54 supporting the boss 50 in the use position in an upward direction and an upper section 55 supporting the boss 50 in the maintenance position in a downward direction. The axis of rotation 46 is formed by the bosses 50. It is also clear from the side view of figure 6, that the center of gravity 56 of the electric box 30 is arranged so that the electric box 30 tends to rotate about the axis of rotation 46 in a clockwise direction that is towards the interior 12 of the external housing 10.

**[0062]** As previously mentioned, the electric box 30 may be releasably fixed to the frame 47 by bolts 57 (see figure 5). When releasing the bolts 57 at the upper end near the top 31 of the electric box 30 from the frame 47, the electric box may be rotated about the axis of rotation 46 or the bosses 50, respectively, in a counterclockwise direction as will be explained in more detail below. For rotating the electric box 30 it is conceivable to provide a handle 64 (see figure 5) in or at an outer surface of the electric box 30.

**[0063]** The cooling heat exchanger 22 is in the present example together with the duct 23 fixed to the frame 47 by bolts. As may be best seen from figure 9, the air outlet 39 or more particularly an opening 59 of the frame 47 facing the air outlet 39 of the air passage 37 is surrounded by an elastic sealing 60. The elastic sealing 60 is as well fixed to the frame 47. The sealing, particularly the contact surface of the sealing facing the electric box 30 defines a plane 61. The center of gravity 56 is in a side view (figure 6) disposed between the plane 61 and the axis of rotation 36 (formed by the boss 50). Thus, the electric box 30 tends to rotate against the contact surface of the sealing 60 by gravity ensuring a proper contact with the sealing at the air outlet 39 between the outlet 39 and the cooling heat exchanger 22 and its optional duct 23. Certainly, other or further possibilities to seal between the outlet 39 and the cooling heat exchanger 22 and its optional duct 23 are conceivable. For example, the sealing could also be established by correct dimensioning and adding sufficient fixation points between the mating surfaces. Moreover, a separate clamping element may be used to press the mating surfaces together.

**[0064]** The electrical components 36 in the electric box 13 need to be connected to some of the components of the refrigerant circuit contained in the external housing 10. For this purpose, the electric box 30 has either an open bottom or an opening is provided in the bottom 35. A first electric wire 62 connected to a first electric component in the electric box 30 leaves the electric box through the bottom end of the electric box 30 and is connected to the first electric component such as the solenoid valve 20 (see figure 2 and figure 8). For this purpose, the electric wire 62 schematically indicated in figure 3 is guided from the bottom 35 to the bottom 14 of the external housing 10, along the bottom 14 and from the bottom 14 to the first electric component (in the example the valve 20).

**[0065]** Under some circumstances and for EMC (electromagnetic compatibility) reasons, some electric wires need to be separated from other electric wires. Accordingly, it is conceivable that a second electric wire 63 leaves the electric box 30 through an opening 70 (see figure 7) between the bottom 35 and the top 31 of the electric box 30. Also the second electric wire 63 is guided to the bottom 14 of the external housing 10 and from the bottom to the component such as the compressor 3. Neither the first electric wire 62 nor the second electric wire 63 is fixed to the bottom 14 of the external housing 10 in the example.

**[0066]** In the case that maintenance of electric components 36 or refrigerant components or the fan 40 of the electric box 30 is required, one has to remove a maintenance wall 106 of the external housing 10 (see figure 4). For this purpose, the bolts 107 are removed and subsequently the maintenance wall 106 can be removed as shown in figure 5. Once the maintenance wall 106 has been removed, one can loosen the bolts 57 at the top end of the electric box 30 (figure 5) and pivot the electric box 30 about the axis of rotation 46, formed by the bosses 50, out through the opening created by removing the maintenance wall 106. During this process, the boss 50 moves from the lower section 54 of the engagement portion 53 of the slot 49 into the upper section 55 of the engagement portion 53 of the slot 49. Accordingly, the electric box 30 is reliably held in the slot 49 and can easily be pivoted.

**[0067]** As will be apparent from the above description, the electric box 30 and the cooling heat exchanger 22 are

**EP 3 361 166 A1**

independently fixed to the support structure 45 (the frame 47). There is no attachment of the electric box 30 to the cooling heat exchanger 22. Accordingly, moving the electric box 30 into the maintenance position (not shown) does not affect the cooling heat exchanger 22 and its refrigerant piping 24. The cooling heat exchanger 22, the duct 23 (if present) and the sealing 60 remain mounted in their position on the frame 47 and are not moved together with the electric box 30. In this context, the fan 40 may as well be fixed to the electric box 30 and may be pivoted into the maintenance position together with the electric box 30 to enable easy maintenance or substitution of a damaged fan 40.

**[0068]** When the electric box 30 is moved into the maintenance position, the first electric wire 62 guided through the bottom 35 of the electric box 30 moves towards the inner side of the external housing 10 and, therefore, in a direction toward the electrical component 20 to which it is connected. Accordingly, no strain is applied to the first electric wire 62 by moving the electric box 30 into the maintenance position.

**[0069]** The second electric wire 63 leaving the electric box through the opening 70 is first guided to the bottom 13 of the external housing 10. Thus, there is a certain free length of the second electric wire 63 between the opening 64 and the connection to the compressor 3. Thus, also in this case strain on the second electric wire 63 can be avoided when moving the electric box 30 into the maintenance position.

**[0070]** The above configuration enables easy access to the electric box and does not require any disassembly/assembly work on the cooling heat exchanger 22 and its refrigerant piping 24. For this reason, damages to the cooling heat exchanger 22 and its refrigerant piping 24 can be prevented.

**[0071]** After the maintenance, the electric box 30 is pivoted about the axis of rotation 46 (bosses 50) in an opposite direction (clockwise in figures 3 and 6) into the use position shown in the drawings. During this process, the boss 50 again moves back to the lower section 54 of the engagement portion 53 of the slot 49 so that the electric box 30 is securely supported in a vertical direction. Because the center of gravity 56 is closer to a plane 61 formed by the contact surface of the sealing 60 than to the axis of rotation 46 (bosses 50) in a side view, the weight of the electric box 30 ensures that the electric box 30 is securely pressed against the contact surface of the sealing 60 and does even without the bolts 57 not "drop" out of the maintenance opening. Subsequently, the bolts 57 are reinserted and the maintenance wall 106 is reinstalled.

**[0072]** Further, a controller 65 is provided which is schematically shown in figure 2. The controller 65 has the purpose of controlling the air conditioner 1 and particularly the refrigerant circuit. The controller 65 may be accommodated in the electric box 30.

**[0073]** The controller 65 may be configured to control the air conditioner 1 on the basis of parameters obtained from different sensors.

**[0074]** For example, a first temperature sensor 66 is disposed in the interior 12 of the external housing 10. Thus, the first temperature sensor 66 detects the temperature in the interior 12 of the external housing 10. In this context, the position of the first temperature sensor 66 is determined relative to the position of the other components in the external casing at a position in which a relatively stable and representative temperature can be measured. Thus, this position has to be determined by experiments.

**[0075]** A second temperature sensor 67 may be arranged in the installation room 29 in which the heat source unit 2 is installed. The second temperature sensor 67, hence, measures a temperature in the installation room 29 in other words the temperature of the environment (exterior) of the external housing 10.

**[0076]** Another parameter used by the controller 65 is a thermistor 68 (third temperature sensor) at an exit line 69 between the cooling heat exchanger 22 and a suction side of the compressor 3 (see figure 2). In one embodiment, it is conceivable that an accumulator 108 is disposed in the line between the cooling heat exchanger 22 and the inlet of the compressor 3 (suction side). In general, the exit line 69 is to be understood as that line connecting the cooling heat exchanger 22 to the gas suction line 26, i.e. between an exit of the cooling heat exchanger 22 and the connection of the bypass line 24 to the gas suction line 26. The thermistor 65 measures the temperature of the refrigerant in the exit line 69. Further, a pressure sensor 71 is provided and configured to measure the pressure of the refrigerant in the gas suction line 26.

**[0077]** The operation of the air conditioner with respect to the cooling heat exchanger 22 is described in more detail below. This operation may also be referred to as the zero heat dissipation control (ZED = zero energy dissipation).

**[0078]** In principle, one can choose between three settings explained in more detail and shown in the table below.

Setting	0	1	2
Zero heat dissipation control	OFF	ON priority on cooling capacity	ON priority on zero heat dissipation

**[0079]** In setting "0", the valve 20 is completely closed and no refrigerant flows through the cooling heat exchanger 22. In this setting, the electric components 36 may still be cooled by operating the fan but the heat is dissipated to the interior 12 of the external casing 10, and hence the external casing 10 and the heat source unit 2 dissipate heat to the

## EP 3 361 166 A1

installation room 29. The zero heat dissipation control is switched OFF.

**[0080]** If setting "1" is selected, zero heat dissipation control is ON. Yet, in this setting, the cooling capacity of the air conditioner has priority over the zero heat dissipation control. In particular, if a temperature measured in a room 105 to be conditioned exceeds a set temperature of the air conditioner in that room 105 by a certain value, and the air conditioner can only satisfy this additional cooling demand if the zero heat dissipation control is deactivated, the valve 20 will be closed. To put it differently, the valve 20 is closed, when a required cooling capacity of the air conditioner exceeds a predetermined threshold. For example, a heat source heat exchanger 5 can transfer a certain amount of heat (further referred to as 100% heat load) to (in this example) water (water circuit 104) at certain operating conditions. During operation with deactivated ZED control, the heat source unit 4 can remove heat from the room (105) in correspondence with 100% heat load (cooling operation). Assuming that the heat loss from the electronic components and hot refrigerant components corresponds to 4% of the total heat load, only 96% of heat load (cooling capacity) can be used to cool the room 105 during cooling operation. If the above setting is activated, the ZED control can be deactivated resulting in a 100% available capacity to cool the room 105. During heating operation of the room 105, the heat source heat exchanger 5 will subtract 100% of heat from the water in the water circuit 104 and deliver this heat, together with the 4% heat loss from the electric components 36, to the room 105. This results in a heating capacity of 104%, whereby the heating performance of the air conditioner 1 is increased.

**[0081]** If setting "2" is selected, zero heat dissipation control is ON independent of the cooling capacity of the air conditioner. However, under a certain special control operations, such as start-up and oil return, zero heat dissipation control is still deactivated (the valve 20 is closed) in order to avoid damaging of the compressor 3 due to liquid refrigerant flowing back into the compressor 3. During start - up mode for example, the rotational speed of the compressor increases to nominal speed. At a low rotational speed, the circulated refrigerant amount is low. Yet, if the distance between the heat source unit 2 and the indoor unit 100 is large, the refrigerant in the liquid line connecting the heat source unit 2 and the indoor unit 100 has a relatively high inertia. In contrast, the bypass line 24 is relatively short and has a low inertia. As a consequence, a higher proportion of the refrigerant flows through the bypass line 24, whereas a reduced amount or even no refrigerant may flow to the indoor unit 100. This may result in lower comfort in the room 105 in which the indoor unit 100 is mounted. This may be prevented by closing the valve 20. During oil return operation, a high mass flow rate is generated to flush oil out of the refrigerant circuit components. If the valve 20 is open, the mass flow rate through the refrigerant circuit component was reduced resulting in a decreased oil return efficiency.

**[0082]** In either case, the zero heat dissipation control may be performed on the basis of different parameters.

**[0083]** According to a first possibility, the temperature of the interior 12 of the external casing 10 is measured by the first temperature sensor 66 and the controller 65 controls the valve 20 on the basis of the temperature measured by the first temperature sensor 66.

**[0084]** In particular, the controller 65 compares the temperature measured by the first temperature sensor 66 with a predetermined temperature. In this embodiment, it is preferred that one either freely inputs the predetermined temperature or can select from different settings as shown in the table below to define the predetermined temperature.

Setting	0	1	2	3	4	5	6	7
Predetermined temperature [°C]	25	27	29	31	33	35	37	39

**[0085]** Further, one either freely inputs a differential temperature or again selects the differential temperature from different settings as shown in the table below to define the differential temperature.

Setting	0	1	2	3
Differential temperature [°C]	3	2	1	5

**[0086]** According to this control, the controller 65 compares the temperature measured by the first temperature sensor 66 with the predetermined temperature. If the temperature measured by the first temperature sensor 66 exceeds the predetermined temperature, the controller 65 is configured to activate the zero heat dissipation control and open the valve 20 (completely).

**[0087]** Then again and as shown in figure 10, if the temperature measured by the first temperature sensor 66 falls below the predetermined temperature minus the selected differential temperature, the controller 65 is configured to deactivate the zero heat dissipation control and close the valve 20 (completely).

**[0088]** For example, if the setting "3" is selected for the predetermined temperature, the predetermined temperature is 31°C. Further, if the setting "0" is selected for the differential temperature, the differential temperature is 3°C. If for example the temperature measured by the first temperature sensor 66 in the interior 12 of the external housing 10

exceeds 31°C, the valve 20 is opened by the controller 65. Accordingly, the refrigerant flows through the capillary 21, is expanded and then flows into the cooling heat exchanger 22. In the cooling heat exchanger, the refrigerant extracts heat from the air flow 41 by heat exchange, whereby the air flow 41 is cooled and cooled air is expelled into the interior 12 of the external housing 10. Thereby also the hot refrigerant components such as the compressor 3, the liquid receiver 8 and the oil separator 9 are cooled, because of the orientation of the air outlet 28 of the cooling heat exchanger 22 in an angled fashion. In particular, the cooled air flow 41 is directed in a direction of the hot refrigerant components which are accordingly cooled. In any case, air that is cooler than the air in the interior 12 of the external housing 10 is expelled from the cooling heat exchanger 22 into the interior 12. As a result, the temperature decreases in the external housing 10. Once the temperature measured by the first temperature sensor 66 falls below 28°C (31°C - 3°C), the controller 65 closes the valve 20 and no refrigerant flows through the cooling heat exchanger 22. This process is repeated as shown in figure 10.

**[0089]** Alternatively or in addition to the above control, it is also conceivable to use a second temperature sensor 67 disposed in the installation room 29 and measuring the temperature in the installation room 29 to control the valve 20.

**[0090]** In this context, it is conceivable that the zero heat dissipation control is activated (the valve 20 is opened) if the temperature detected by the first temperature sensor 66 is higher than the temperature measured by the second temperature sensor 67. For example, it may be that the controller 65 overrides the above control related to the 1<sup>st</sup> temperature sensor 66, if the temperature measured by the second temperature sensor 67 is lower than the temperature detected by the first temperature sensor 66 and closes the valve 20 despite the fact that the temperature measured by the first temperature sensor 66 is higher than the predetermined temperature.

**[0091]** An even further possibility is that instead of using the first temperature sensor 66 to merely use the second temperature sensor 67 and control the valve 20 on the basis of a comparison between the temperature measured by the second temperature sensor 67 and a predetermined temperature in the same manner as explained above with respect to the first temperature sensor 66.

**[0092]** According to a first example, it may be sufficient to compare the predetermined temperature and the temperature measured by the second temperature sensor 67 and if the temperature of the second temperature sensor 67 exceeds the selected predetermined temperature, the valve 20 is opened to activate the zero heat dissipation control. Subsequently, if the temperature measured by the second temperature sensor 67 falls below the predetermined temperature minus the differential temperature, the valve 20 is again closed.

**[0093]** According to a second example, it is as well conceivable to define a second differential temperature in the same manner as the first differential temperature. If the temperature measured by the second temperature sensor 67 is higher than the predetermined temperature and the delta between the temperature measured by the second temperature sensor 67 and the predetermined temperature is higher than the second differential temperature, the valve 20 is opened. In the same manner as described above, if the temperature measured by the second temperature sensor 67 falls below the predetermined temperature by the first differential temperature, the valve 20 is closed and the zero heat dissipation control is deactivated.

**[0094]** An even further control mechanism to activate/deactivate the zero heat dissipation control (open/close the valve 20) may be based on the thermistor 68 disposed at the exit line 69 and particularly the temperature of the refrigerant in the exit line 69 measured by the thermistor 68. Further, the controller 65 uses the pressure measured by the pressure sensor 71 disposed at the gas suction line 26. In particular, the controller 65 concludes on the two-phase temperature (the temperature at which a phase change from liquid to gas takes place) on the basis of the pressure measured by the pressure sensor 71. Subsequently, the controller 65 compares this two-phase temperature and the temperature measured by the thermistor 68. If the temperature measured by the thermistor 68 is higher than the two-phase temperature, it is concluded that superheated gaseous refrigerant leaves the cooling heat exchanger 22. The output of the thermistor 68 is, hence, used by the controller 65 to conclude or calculate on the basis of a pressure in the gas suction line 26 and the temperature at an outlet of the cooling heat exchanger 22 (cooling heat exchanger gas outlet) on a superheat degree. Subsequently, and depending on the superheat degree open or close the valve 20. This control is particularly a safety measure to prevent liquid refrigerant from remaining in the exit line 26 and/or being pumped into the accumulator 108 (if present) or the compressor 3. In particular, the controller 65 is configured to switch to the OFF-mode of the valve 20, when the calculated superheat degree falls below a predetermined value for a predetermined period of time. During operation, the pressure difference between the liquid line 25 and the gas suction line 26 will depend on the operational conditions of the heat source unit 2. If there is a pressure drop in the bypass line 24, a refrigerant flow may be induced from the gas suction line 26 into the bypass line 24. Depending on the air temperature in the external housing 10, the refrigerant flowing through the cooling heat exchanger 22 and the thermal capacity of the air may be out of balance resulting in a fully evaporated refrigerant with a possible high superheat or a not fully evaporated refrigerant which contains liquid refrigerant. Those extreme situations may be avoided by opening/closing the valve 20 on the basis of the superheat degree obtained via the thermistor.

## EP 3 361 166 A1

### Reference list

	Air conditioner	1
	Heat source unit	2
5	Compressor	3
	4-Way valve	4
	Heat source heat exchanger	5
	Expansion valve	6
10	Optional expansion valve	7
	Liquid receiver	8
	Oil separator	9
	External housing	10
	Exterior of the external housing	11
15	Interior of the external housing	12
	Top of the external housing	13
	Bottom of the external housing	14
	Side walls of the external housing	15
20	Vents	16
	Valve	20
	Capillary	21
	Cooling heat exchanger	22
	Duct	23
25	Bypass line	24
	Liquid refrigerant line	25
	Gas suction line	26
	Air inlet of cooling heat exchanger	27
30	Air outlet of the cooling heat exchanger	28
	Installation room	29
	Electric box	30
	Top of the electric box	31
	Back of the electric box	32
35	Front of the electric box	33
	Sides of the electric box	34
	Bottom of the electric box	35
	Electrical components	36
40	Air passage	37
	Air inlet of the air passage	38
	Air outlet of the air passage	39
	Fan	40
	Air flow	41
45	Fins	42
	Tubes	43
	Bottom end portion of the cooling heat exchanger	44
50	Support structure	45
	Axis of rotation	46
	Frame	47
	Column	48
	Slot	49
55	Boss	50
	Insertion portion	51
	Opening of the insertion portion	52

## EP 3 361 166 A1

(continued)

	Engagement portion	53
	Lower section	54
5	Upper section	55
	Center of gravity	56
	Bolts	57
	Opening	59
10	Sealing	60
	Plane of the contact surface of the sealing	61
	First electric wire	62
	Second electric wire	63
	Handle	64
15	Controller	65
	First temperature sensor	66
	Second temperature sensor	67
	Thermistor	68
20	Exit line	69
	Opening	70
	Pressure sensor	71
	Indoor unit	100 to 102
	Indoor heat exchanger	103
25	Water circuit	104
	Rooms	105
	Maintenance wall	106
	Bolts	107
	Accumulator	108
30	Outdoor unit	109

### Claims

35 1. Heat source unit (2) for an air conditioner (1) comprising a refrigerant circuit, the heat source unit comprising:

an external housing (10) accommodating:

40 a compressor (3) to be connected to the refrigerant circuit;  
a heat source heat exchanger (5) to be connected to the refrigerant circuit and configured to exchange heat between a refrigerant circulating in the refrigerant circuit and a heat source (104);  
an electric box (30) having a top (31) and side walls (32 to 34), the electric box accommodating electrical components (36) configured to control the air conditioner and having an air passage (37) comprising an air inlet (38) and an air outlet (39), an air flow (41) being induced through the air passage from the air inlet to  
45 the air outlet for cooling at least some of the electrical components,

#### characterized by

50 a cooling heat exchanger (22) accommodated in the external housing and to be connected to the refrigerant circuit, wherein the cooling heat exchanger (22) is arranged at one of the side walls (32 to 34) of the electric box so as to be flown through by the air flow (41) and exchange heat between the refrigerant and the air flow (41).

2. Heat source unit according claim 1, wherein the cooling heat exchanger (22) is disposed, in the direction of the air flow (41), downstream of electrical components (36) and/or a heat sink heat conductively connected to electrical components disposed in the air passage (37).

55 3. Heat source unit according to claim 1 or 2, wherein a fan (40) is provided in the external housing (10) and configured to induce the air flow (41) through the air passage

**EP 3 361 166 A1**

(37) from the air inlet (38) to the air outlet (39).

4. Heat source unit according to claim 3, wherein the fan (40) is disposed at the air outlet (39).

5 5. Heat source unit according to any one of the preceding claims, wherein an air outlet (28) of the cooling heat exchanger (22) is oriented to expel air from the air passage (37) leaving the cooling heat exchanger in a direction of hot refrigerant components (3, 8, 9) accommodated in the external housing (10).

10 6. Heat source unit according to any one of the preceding claims, wherein the air outlet (39) of the air passage (37) is located closer to a top (13) than to a bottom (14) of the external housing (10).

7. Heat source unit according to any one of the preceding claims, wherein the cooling heat exchanger (22) is connected to a bypass line (24) branched from a liquid refrigerant line (25) and a gas suction line (26).

15 8. Heat source unit according to claim 7, wherein the bypass line (24) has a valve (20) and a capillary (21) both upstream of the cooling heat exchanger (22).

20 9. Heat source unit according to any one of the preceding claims, wherein a bottom end portion (44) of the cooling heat exchanger (22) slopes downward towards an air outlet (28) of the cooling heat exchanger.

10. Heat source unit according to any one of the preceding claims, wherein the cooling heat exchanger (22) has a plurality of fins (42) and tubes (43), wherein the fins are arranged with a longitudinal extension along a vertical direction.

25 11. Air conditioner (1) having a heat source unit (2) according to any one of the preceding claims connected to at least one indoor unit (100 to 102) having an indoor heat exchanger (103) forming the refrigerant circuit.

30

35

40

45

50

55

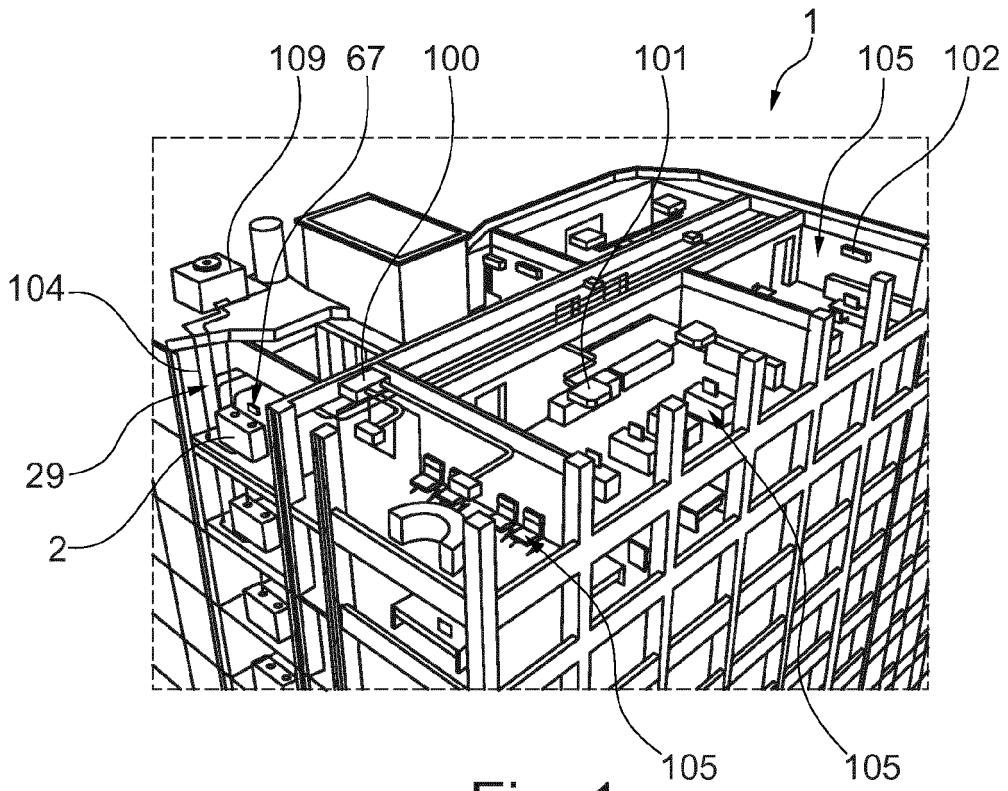

Fig. 1

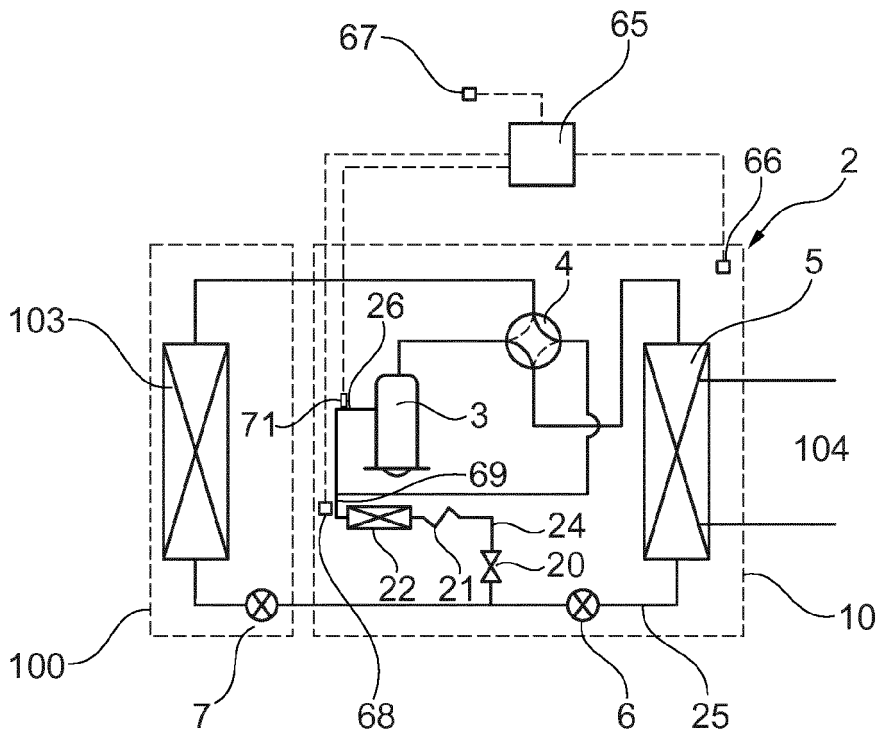

Fig. 2



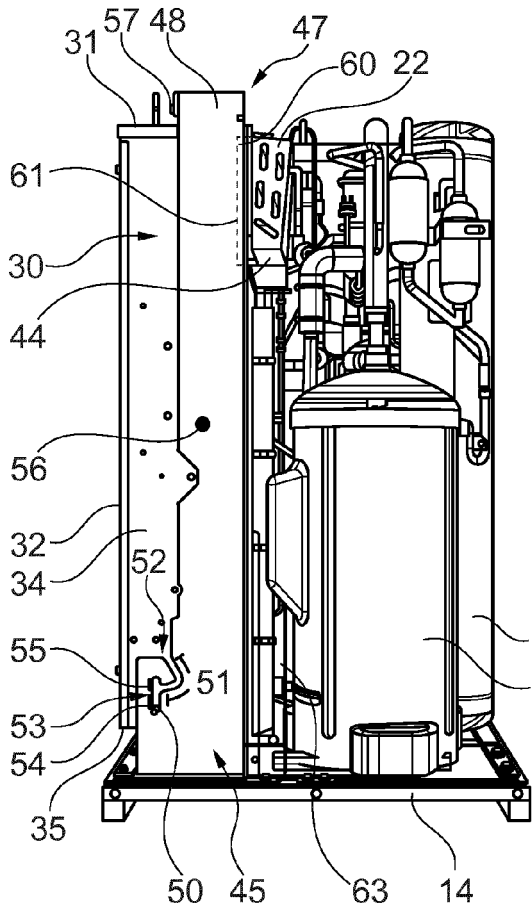

Fig. 6

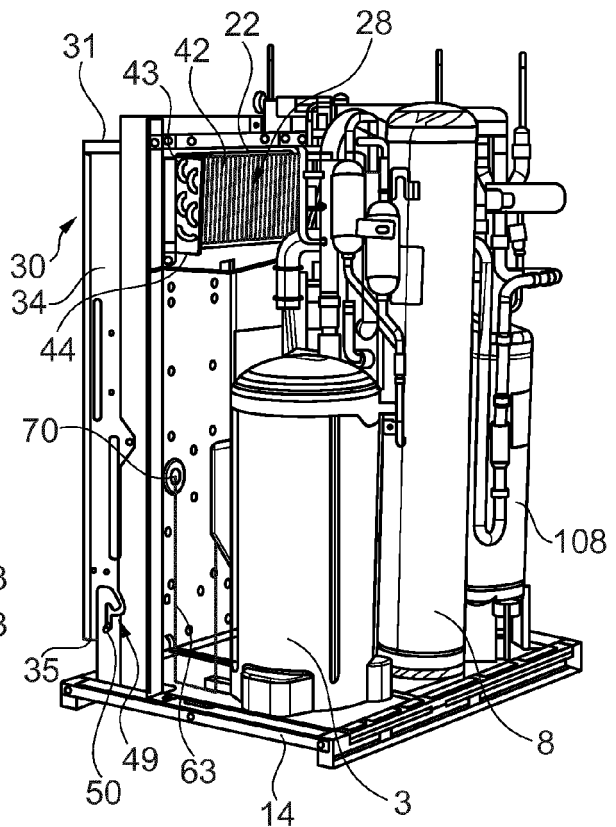

Fig. 7

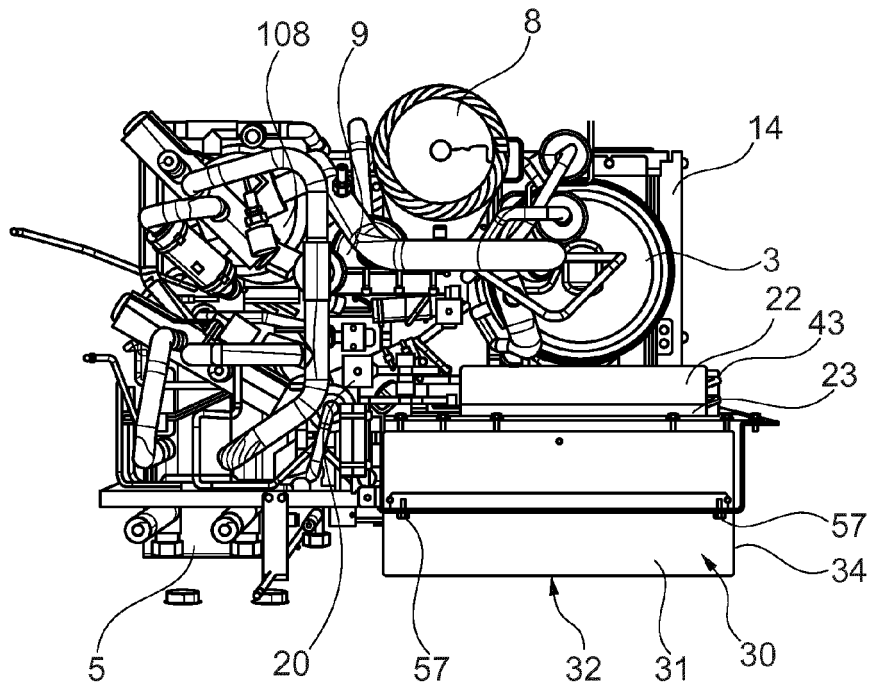

Fig. 8

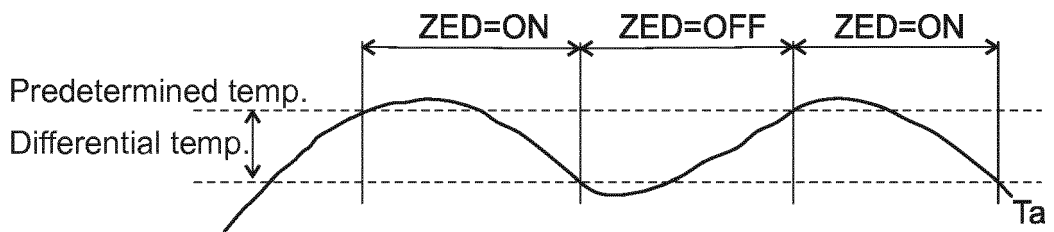
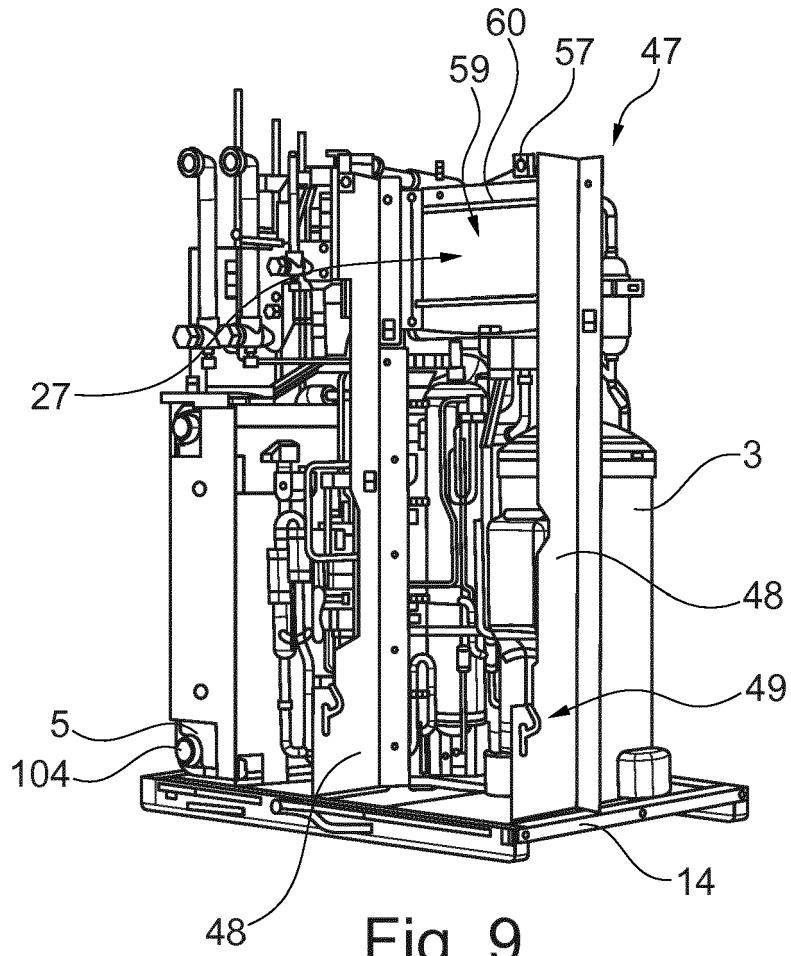

Fig. 10



EUROPEAN SEARCH REPORT

Application Number  
EP 17 15 5592

5

10

15

20

25

30

35

40

45

50

55

DOCUMENTS CONSIDERED TO BE RELEVANT			
Category	Citation of document with indication, where appropriate, of relevant passages	Relevant to claim	CLASSIFICATION OF THE APPLICATION (IPC)
X	WO 2015/002493 A1 (LG ELECTRONICS INC [KR]) 8 January 2015 (2015-01-08) * abstract; figures 1,2 * -----	1-11	INV. F24F1/14 F24F1/16 F24F1/24
A	US 2016/320077 A1 (KIM KYUNG HOON [KR] ET AL) 3 November 2016 (2016-11-03) * claim 1; figures 1-10 * -----	1-10	
A,D	US 2016/258636 A1 (KIM JONG TAE [KR] ET AL) 8 September 2016 (2016-09-08) * the whole document * -----	1-10	
A,D	JP 2016 191505 A (DAIKIN IND LTD) 10 November 2016 (2016-11-10) * the whole document * -----	1-10	
The present search report has been drawn up for all claims			TECHNICAL FIELDS SEARCHED (IPC)
			F24F
Place of search		Date of completion of the search	Examiner
Munich		19 July 2017	Decking, Oliver
CATEGORY OF CITED DOCUMENTS			
X : particularly relevant if taken alone Y : particularly relevant if combined with another document of the same category A : technological background O : non-written disclosure P : intermediate document		T : theory or principle underlying the invention E : earlier patent document, but published on, or after the filing date D : document cited in the application L : document cited for other reasons ..... & : member of the same patent family, corresponding document	

1  
EPO FORM 1503 03/02 (P04C01)

ANNEX TO THE EUROPEAN SEARCH REPORT  
ON EUROPEAN PATENT APPLICATION NO.

EP 17 15 5592

5

This annex lists the patent family members relating to the patent documents cited in the above-mentioned European search report. The members are as contained in the European Patent Office EDP file on  
The European Patent Office is in no way liable for these particulars which are merely given for the purpose of information.

19-07-2017

10

15

20

25

30

35

40

45

50

55

Patent document cited in search report	Publication date	Patent family member(s)	Publication date
WO 2015002493 A1	08-01-2015	EP 3017255 A1	11-05-2016
		KR 20150005338 A	14-01-2015
		US 2016174411 A1	16-06-2016
		WO 2015002493 A1	08-01-2015
-----			
US 2016320077 A1	03-11-2016	CN 106091168 A	09-11-2016
		EP 3112769 A2	04-01-2017
		KR 20160129357 A	09-11-2016
		US 2016320077 A1	03-11-2016
-----			
US 2016258636 A1	08-09-2016	CN 105612390 A	25-05-2016
		EP 3015777 A1	04-05-2016
		KR 20150042319 A	21-04-2015
		US 2016258636 A1	08-09-2016
		WO 2015053554 A1	16-04-2015
-----			
JP 2016191505 A	10-11-2016	NONE	
-----			

**REFERENCES CITED IN THE DESCRIPTION**

*This list of references cited by the applicant is for the reader's convenience only. It does not form part of the European patent document. Even though great care has been taken in compiling the references, errors or omissions cannot be excluded and the EPO disclaims all liability in this regard.*

**Patent documents cited in the description**

- JP 2016191505 A [0003]
- US 20160258636 A1 [0004] [0005]