



(11)

EP 3 373 411 B1

(12) **EUROPEAN PATENT SPECIFICATION**

(45) Date of publication and mention of the grant of the patent:
26.07.2023 Bulletin 2023/30

(21) Application number: **16862488.0**

(22) Date of filing: **04.11.2016**

(51) International Patent Classification (IPC):
H02J 50/12 ^(2016.01) **H01F 38/14** ^(2006.01)
H02J 7/02 ^(2016.01) **H02J 5/00** ^(2016.01)

(52) Cooperative Patent Classification (CPC):
H02J 50/12; B60L 53/122; B60L 53/124;
B60L 53/126; B60L 53/38; H01F 38/14;
H02J 7/00304; H02J 7/00308; H02J 50/90;
H02J 7/00309; Y02T 10/70; Y02T 10/7072;
Y02T 90/12; Y02T 90/14

(86) International application number:
PCT/KR2016/012682

(87) International publication number:
WO 2017/078473 (11.05.2017 Gazette 2017/19)

(54) **WIRELESS POWER TRANSMITTER AND RECEIVER FOR VEHICLE**

DRAHTLOSER STROMSENDER UND -EMPFÄNGER FÜR EIN FAHRZEUG

ÉMETTEUR ET RÉCEPTEUR DE PUISSANCE SANS FIL POUR UN VÉHICULE

(84) Designated Contracting States:
AL AT BE BG CH CY CZ DE DK EE ES FI FR GB
GR HR HU IE IS IT LI LT LU LV MC MK MT NL NO
PL PT RO RS SE SI SK SM TR

(30) Priority: **05.11.2015 US 201562251118 P**

(43) Date of publication of application:
12.09.2018 Bulletin 2018/37

(60) Divisional application:
23179257.3

(73) Proprietor: **LG Electronics Inc.**
Yeongdeungpo-gu
Seoul 07336 (KR)

(72) Inventors:
• **PARK, Jinmoo**
Seoul 06772 (KR)

- **SEO, Jeongkyo**
Seoul 06772 (KR)
- **CHAE, Beomseok**
Seoul 06772 (KR)
- **LEE, Jaesung**
Seoul 06772 (KR)
- **LEE, Jihyun**
Seoul 06772 (KR)

(74) Representative: **Frenkel, Matthias Alexander**
Wuesthoff & Wuesthoff
Patentanwälte PartG mbB
Schweigerstraße 2
81541 München (DE)

(56) References cited:
WO-A1-2015/021144 CN-U- 202 695 109
KR-A- 20150 069 440 KR-A- 20150 082 419
KR-A- 20150 093 588 KR-A- 20150 093 588
US-A1- 2013 328 412 US-A1- 2014 070 622

EP 3 373 411 B1

Note: Within nine months of the publication of the mention of the grant of the European patent in the European Patent Bulletin, any person may give notice to the European Patent Office of opposition to that patent, in accordance with the Implementing Regulations. Notice of opposition shall not be deemed to have been filed until the opposition fee has been paid. (Art. 99(1) European Patent Convention).

Description**[Technical Field]**

5 **[0001]** The present invention relates to a structure for a wireless power transmitter and receiver for a vehicle and a method for controlling the same.

[Background Art]

10 **[0002]** A contactless wireless charging method is an energy transfer method for electromagnetically transferring energy without using a wire in a method for sending energy through an existing wire so that the energy is used as power for an electronic device. The contactless wireless transmission method includes an electromagnetic induction method and a resonant method. In the electromagnetic induction method, a power transmission unit generates a magnetic field through a power transmission coil (i.e., a primary coil), and a power reception coil (i.e., a secondary coil) is placed at the location where an electric current may be induced so that power is transferred. In the resonant method, energy is transmitted using a resonant phenomenon between the transmission coil and the reception coil. In this case, a system is configured so that the primary coil and the secondary coil have the same resonant frequency, and resonant mode energy coupling between the transmission and reception coils is used.

15 **[0003]** US 2014/070622 A1 discloses an apparatus for wirelessly transmitting power. The apparatus includes a first conductive structure configured to generate a first magnetic field based on a first current received from a power source. The apparatus further includes a second conductive structure configured to generate a second magnetic field based on a second current from the power source. The apparatus further includes a controller configured to determine a respective coupling coefficient between each of the first and second conductive structures and a third conductive structure configured to receive power via the first or the second magnetic field. The controller is further configured to adjust the first or second current applied to the first and second conductive structures based at least in part on the coupling coefficients.

20 **[0004]** KR 2015 0093588 A discloses a wireless power receiving apparatus comprising a power receiving part changing a magnetic flux into a current to wirelessly receive power; and a power control part connected to the power receiving part, and changing a resonant frequency to control power received from the power receiving part, wherein the power control part comprises a first capacitor; a second capacitor connected to the first capacitor in parallel; a first switch connected to the second capacitor in series, entering current in the first direction and a second switch entering current in the second direction opposite to the first direction; and a switch control part controlling the first and second switches.

25 **[0005]** CN 202 695 109 U discloses a transmitting coil winding structure for a rectangular positioning-free wireless charger, which comprises a heat-radiating fin, a ferrite magnetic sheet fitted with the heat-radiating fin and a coil winding fitted with the ferrite magnetic sheet, wherein the coil winding is a three-dimensional structure body divided by a plurality of rectangular coils into at least two layers and arranged in a rectangular shape from the bottom up. The coil winding is arranged in a rectangular shape from the bottom up. Moreover, the wireless charger can cover the charging application of above 90 percent of portable mobile equipment with below 5 watts of power.

[Disclosure]

40

[Technical Problem]

[0006] The present invention provides a novel coil assembly structure for a wireless power transmitter for a vehicle that has good charging efficiency/performance, and a method of operating such a wireless power transmitter for a vehicle.

45

[Technical Solution]

[0007] The invention is defined by the appended claims. An embodiment of the present invention provides a wireless power transmitter for a vehicle that transfers power to a wireless power receiver, including: a coil assembly comprising first and second bottom coils placed adjacent to each other in a line and each consisting of a single layer of 11 turns and a top coil stacked on the first and second bottom coils and consisting of a single layer of 12 turns; and a full-bridge inverter driving each of coils included in the coil assembly individually, wherein the first and second bottom coils and the top coil have a substantially rectangular frame structure with a through hole in the center, the top coil lies on a plane surface in the middle between the first and second bottom coils, and a distance from the center of the first and second bottom coils to the center of the top coil is set to a range of 23 mm to 25 mm.

50 **[0008]** Also, a level of power transferred to the wireless power receiver by the coil assembly is controlled based on a level of input voltage applied to the full-bridge inverter.

[0009] Also, the level of voltage applied to the full-bridge inverter is adjusted within a range of 1 V to 18 V.

[0010] Also, an operating frequency of the coil assembly is fixed within a range of 140 to 150 kHz.

[0011] Also, the first and second bottom coils may have a height of 48 mm to 50 mm and a width of 47 mm to 49 mm, and the through hole in the first and second bottom coils may have a height and width of 18 mm to 20 mm.

5 [0012] Also, the top coil may have a height of 45 mm to 47 mm and a width of 48.5 mm to 50.5 mm, and the through hole in the first and second coils may have a height of 20 mm to 22mm and a width of 24.5 mm to 26.5 mm.

[0013] Also, a thickness of the first and second bottom coils and the top coil is set to a range of 0.9 mm to 1.3 mm.

[0014] Also, the first and second bottom coils and the top coil may have the same inductance value.

10 [0015] Also, the first and second bottom coils and the top coil have the same inductance value within a range of 10.6 μ H to 12.0 μ H.

[Technical Effects]

15 [0016] According to an embodiment of the present invention, the application of a multi-coil driving scheme to a coil assembly widens the chargeable area but minimizes the unchargeable area, thereby increasing the charging performance/efficiency.

[0017] Also, according to an embodiment of the present invention, it is possible to prevent frequency interference with other electronic parts/equipment within the vehicle as the power transmitter operates at a fixed operating frequency.

20 [0018] Also, according to an embodiment of the present invention, the power transmitter has a very wide adjustable input voltage range of 1 V to 18 V, and supports high input voltage, thus increasing the z distance d_z and enabling long-distance charging. This gives vehicle manufacturers a greater degree of freedom in the installation of a power transmitter in a vehicle.

[0019] Other advantages of embodiments of the present invention will be described below in detail.

[Brief Description of the Drawings]

25 [0020]

FIG. 1 shows an embodiment of various electronic devices into which a wireless charging system is introduced.

30 FIG. 2 is a block diagram of a wireless power transmission/reception system in accordance with an embodiment of the present invention.

FIG. 3 is a block diagram of a power transmitter in accordance with an embodiment of the present invention.

FIG. 4 is a diagram illustrating a coil assembly structure for a power transmitter in accordance with an embodiment of the present invention.

35 FIG. 5 illustrates a coil structure in accordance with an embodiment of the present invention.

FIG. 6 is a diagram illustrating a shielding structure that covers a coil assembly in accordance with an embodiment of the present invention.

FIG. 7 is a diagram illustrating an equivalent circuit of a power transmitter in accordance with an embodiment of the present invention.

40 FIGS. 8 and 9 show test results of the power transfer performance of a power transmitter designed in accordance with an embodiment of the present invention.

FIGS. 10 and 11 show test results of the transmit power level adjustment function of a power transmitter designed in accordance with an embodiment of the present invention.

45 FIGS. 12 and 13 show test results of the thermal performance of a power transmitter designed in accordance with an embodiment of the present invention.

[Best mode for Invention]

50 [0021] Terms used in this specification are common terms which are now widely used by taking into consideration functions in this specification, but the terms may be changed depending on an intention of those skilled in the art, a use practice, or the appearance of a new technology. Furthermore, in a specific case, some terms have been randomly selected by the applicant. In this case, the meaning of a corresponding term is described in a corresponding part of a corresponding embodiment. Accordingly, the terms used in this specification should not be understood simply based on their names, but should be understood based on their substantial meanings and contents over this specification.

55 [0022] Furthermore, although embodiments of the present invention are described in detail with reference to the accompanying drawings and contents described in the drawings, the present invention is not limited to or restricted by the embodiments.

[0023] Hereinafter, some embodiments of the present invention are described in detail with reference to the accompanying drawings.

[0024] For the standardization of wireless power transmitter/receivers, Wireless Power Consortium (WPC) standardizes technologies related to wireless power transmission/reception.

[0025] A recently developed wireless charging system may support the transmission/reception of low power of about 5 W. In this case, there is a problem in that a charging time is long and efficiency is low in such a low power charging method because the size of a mobile device and the capacity of a battery are recently increased. Accordingly, a wireless charging system supporting the transmission/reception of middle power of about 15 W~20 W is developed. Furthermore, in order to improve charging efficiency, a wireless charging system to which a resonant method for simultaneously charging a plurality of electronic devices has been added is developed.

[0026] An embodiment of the present invention relates to a wireless charging system to which the resonant method has been added and proposes a wireless charging transmitter/receiver using the resonant method, which is compatible with a wireless charging transmitter/receiver using an electromagnetic induction method supporting low power/middle power.

[0027] A wireless power transmitter and wireless power receiver of a resonant type proposed by an embodiment of the present invention and a wireless charging method and a communication protocol using the wireless power transmitter and wireless power receiver are described below. Furthermore, a wireless power transmitter may be abbreviated as a power transmitter or a transmitter, and a wireless power receiver may be abbreviated as a power receiver or a receiver.

[0028] FIG. 1 shows an embodiment of various electronic devices into which a wireless charging system is introduced.

[0029] FIG. 1 shows that electronic devices are classified depending on an amount of power that is transmitted and received in a wireless charging system.

[0030] Referring to FIG. 1, a small power (about 5 W or less or about 20 W or less) wireless charging method may be applied to wearable devices, such as a smart watch, smart glass, a head mounted display (HMD), and a smart ring, and mobile electronic devices (or portable electronic devices), such as an earphone, a remote controller, a smart phone, a PDA, and a tablet PC. A middle power (about 50 W or less or about 200 W or less) wireless charging method may be applied to middle/small-sized home appliances, such as a notebook computer, a robot clearer, a TV, an audio equipment, a vacuum and a monitor. A large power (about 2 kW or less or 22 kW or less) wireless charging method may be applied to kitchen equipment, such as a mixer, a microwave, and an electric rice cooker, and personal mobile devices (or electronic devices/mobile means), such as a wheel chair, an electric kickboard, an electric bicycle, and an electric vehicle.

[0031] Each of the aforementioned electronic devices/mobile means (or shown in FIG. 1) may include a wireless power receiver to be described later. Accordingly, the aforementioned electronic devices/mobile means may be wirelessly charged with power received from a wireless power transmitter.

[0032] Hereinafter, a mobile device to which the small wireless charging method is applied is chiefly described for convenience of description, but this is only an embodiment. A wireless charging method in accordance with an embodiment of the present invention may be applied to the aforementioned various electronic devices.

[0033] FIG. 2 is a block diagram of a wireless power transmission/reception system in accordance with an embodiment of the present invention.

[0034] Referring to FIG. 2, a wireless power transmission/reception system 2000 includes a mobile device 2010 configured to wirelessly receive power and a base station 2020 configured to wirelessly transfer (or transmit) power. Hereinafter, the mobile device may also be called a "power receiver product", and the base station may also be called a "power transmitter product."

[0035] The mobile device 2010 includes a power receiver 2011 for wirelessly receiving power through a secondary coil and a load 2012 for receiving power received by the power receiver 2011, storing the received power, and supplying the stored power to a device.

[0036] The power receiver 2011 may include a power pick-up unit 2013 and a communications & control unit 2014. The power pick-up unit 2013 may receive a wireless power signal through the secondary coil and convert the received signal into electric energy. The communications & control unit 2014 may control the transmission/reception of a power signal (or power).

[0037] The base station 2020 is a device for providing inductive power or resonant power, and may include at least one power transmitter 2021 or a system unit 2024.

[0038] The power transmitter 2021 may send inductive power or resonant power and control such transmission. The power transmitter 2021 may include a power conversion unit 2022 configured to convert electric energy into a power signal by generating a magnetic field through a primary coil(s) and a communications & control unit 2023 configured to control communication and power transfer with the power receiver 2011 so that power of a proper level is transferred. The system unit 2024 may perform control of other operations of the base station 2020, such as input power provisioning, control of a plurality of power transmitters, and control of a user interface.

[0039] The power transmitter 2021 may control transmission power by controlling an operating point. The controlled operating point may correspond to a combination of a frequency (or phase), a duty cycle, a duty ratio, and voltage amplitude. The power transmitter 2021 may control transmission power by controlling at least one of a frequency (or phase), a duty cycle, a duty ratio, or voltage amplitude.

[0040] Furthermore, the power transmitter 2021 may supply constant power, and the power receiver 2011 may control reception power by controlling a resonant frequency.

[0041] In this specification, a (primary/secondary) coil or a coil unit may also be called a coil assembly, a coil cell, or a cell which includes a coil and at least one element close to the coil.

5 **[0042]** FIG. 3 is a block diagram of a power transmitter in accordance with an embodiment of the present invention.

[0043] Referring to FIG. 3, the power transmitter 3000 may include two main units: a power conversion unit 3020 and a communications & control unit 3010. The power conversion unit 3020 may perform communication with the communications & control unit 3010.

10 **[0044]** The power conversion unit 3020 may be in charge of/include the analog part of a power transmitter design. The power conversion unit 3020 may include an inverter, a primary coil selection block, and/or a current sense unit. The power conversion unit 3020 (or inverter) may receive DC (direct current) input and convert it to an AC waveform for operating a resonant circuit including a series capacitor and a primary coil(s). Here, the primary coil may refer to a coil that is appropriately selected from among at least one coil in the power transmitter depending on the location of the power receiver, in order to charge the power receiver.

15 **[0045]** The power conversion unit 3020 (or coil selection block) may select at least one coil in a proper position to charge the power receiver, from among the coils included in a coil assembly, depending on the location of the power receiver placed on the coil assembly.

[0046] Coil selection may be done/performed in real time by the power transmitter 3000 (or power conversion unit 3020/coil selection block) by performing/attempting communication with the power receiver using at least one coil included in the coil assembly (or all the coils in sequence). That is, the power transmitter 3000 (or power conversion unit 3020/coil selection block) may find the location of the power receiver by performing communication with the power receiver using at least one coil, and may select one coil corresponding to the location of the power receiver,

20 **[0047]** For example, the power transmitter 3000 (or power conversion unit 3020/coil selection block) may attempt communication with the power receiver using at least one coil included in the coil assembly, and it can be assumed that an attempt to communicate with the power receiver using the first coil among them has succeeded. In this case, the power transmitter 3000 (or power conversion unit 3020/coil selection block) may determine/predict that the power receiver is currently placed on the first coil (or closest to the first coil), and may select the first coil as a coil to be driven for charging the power receiver.

25 **[0048]** Alternatively, although not shown in the drawing, the power transmitter 3000 may have a separate sensor (e.g., a proximity sensor, infrared sensor, etc.) for finding the location of the power receiver. In this case, the power transmitter 3000 may find the location of the power receiver by using the corresponding sensor, and may select a coil in a proper position to charge the power receiver as a drive coil.

30 **[0049]** Lastly, the power conversion unit 3020 (or current sense unit) may continuously monitor the current flowing through a selected coil.

35 **[0050]** The communications & control unit 3010 may be in charge of/include the digital logic part of a power transmitter design including a coil assembly.

[0051] More specifically, the communications & control unit 3010 may receive and decode a message from the power receiver, constitute a coil selection block to connect with a proper coil, and execute a power control algorithm/protocol related to the coil selection block. Moreover, the communications & control unit 3010 may control/drive the frequency of an AC waveform for controlling power transfer. In addition, the communications & control unit 3010 may interface with other subsystems of the base station (for the purpose of user interfacing, for example).

40 **[0052]** Although this block diagram shows and describes the power conversion unit 3000 and the communications & control unit 3010 separately, the present invention is not limited to this and at least one of the functions of the power conversion unit 3000 may be performed by the communications & control unit 3010 or at least one of the functions of the communications & control unit 3010 may be performed by the power conversion unit 3000. Furthermore, the power conversion unit 3000 and the communications & control unit 3010 may be configured as separate chips or built into one chip.

45 **[0053]** So far, the block diagram of the power transmitter 3000 in accordance with an embodiment of the present invention has been described. Below is a description of a coil assembly structure that may be included in the power transmitter 3000.

50 **[0054]** FIG. 4 is a diagram illustrating a coil assembly structure for a power transmitter in accordance with an embodiment of the present invention.

[0055] Referring to FIG. 4, the coil assembly for a power transmitter in accordance with an embodiment of the present invention may include three coils. Each of the three coils may have a substantially rectangular frame structure with a through hole in the center.

55 **[0056]** The coil assembly may include two bottom coils (or referred to as "bottom primary coils") arrayed and placed in a line and a top coil (or referred to as "top primary coil") placed on (or over) the bottom coils. In other words, the coil assembly may have a stack structure of a plurality of coils stacked on a plane surface to overlap, with the bottom coils

being arranged on a first layer, and the top coil being stacked on the first layer.

[0057] If one of the two bottom coils included in the coil assembly is referred to as a first bottom coil and the other as a second bottom coil, the distance d_{12} from the center of the first bottom coil to the center of the second bottom coil may be about 46 ± 4 mm. The top coil may be placed orthogonal to the bottom coils, and may lie in the middle between the two bottom coils arrayed in a line. The distance d_{bt} from the center of the first and/or second bottom coil to the center of the top coil may be about 23 ± 2 mm. Although not shown in this drawing, the distance d_z from the top surface of the coil assembly (or the top surface of the top coil) to the interface surface of the base station may be about 5.5 ± 1.5 mm. Here, the interface surface may refer to a flat surface closest to the primary coils, among a plurality of surfaces constituting the base station, or refer to a flat surface closest to the secondary coil, among the surfaces of the mobile device. The self inductance L_p of each coil (or primary coil) may be about 11.3 ± 0.7 μ H.

[0058] The following is a more detailed description of a structure of each of the coils (or primary coils - i.e., the bottom coils and the top coil) constituting the coil assembly proposed in this specification.

[0059] FIG. 5 illustrates a coil structure in accordance with an embodiment of the present invention. Specifically, FIG. 5(a) is a diagram illustrating a bottom coil structure, and FIG. 5(b) is a diagram illustrating a top coil structure. Hereinafter (or in this specification), the bottom coil and the top coil will be commonly referred to as "primary coils" for convenience of explanation.

[0060] The primary coils may be wire-wound type, and may consist of a 17 AWG (American wire gauge) litz wire made from 105 strands of 40 AWG wire (0.08 mm in diameter), or a litz wire of similar type or structure. As previously described, the primary coils may include two types of rectangular coils (bottom coil and top coil), and each coil may consist of a single layer. Each primary coil may be designed to have the same inductance value so as to be independent from the distance from ferrite.

[0061] The bottom coil may be placed close to the ferrite in the power transmitter, and the bottom coil may have specific parameter values as presented in the table shown in FIG. 5(a).

[0062] Referring to the table shown in (a) of FIG. 5, the bottom coil may be designed to have an outer length (or outer height) d_{ol} of about 49.0 ± 1.0 mm, an inner length (or inner height) d_{il} of about 26.0 ± 1.0 mm (or about 19.0 ± 1.0 mm), an outer width d_{ow} of about 44.0 ± 1.0 mm (or about 48.0 ± 1.0 mm), an inner width d_{iw} of about 22.0 ± 1.0 mm (or about 19.0 ± 1.0 mm), and a thickness d_c of about 1.1 ± 0.2 mm. The bottom coil may be designed to have a single-layer structure, and the number N of turns per layer in the bottom coil may be 11.

[0063] The top coil may be placed close to the interface of the power transmitter, and the top coil may have specific parameter values as presented in the table shown in FIG. 5(b).

[0064] Referring to the table shown in FIG. 5(b), the top coil may be designed to have an outer length (or outer height) d_{ol} of about 46.0 ± 1.0 mm, an inner length (or inner height) d_{il} of about 21.0 ± 1.0 mm, an outer width d_{ow} of about 49.5 ± 1.0 mm, an inner width d_{iw} of about 25.5 ± 1.0 mm, and a thickness d_c of about 1.1 ± 0.2 mm. The top coil may be designed to have a single-layer structure, and the number N of turns per layer in the top coil may be 12.

[0065] FIG. 6 is a diagram illustrating a shielding structure that covers a coil assembly in accordance with an embodiment of the present invention.

[0066] Referring to FIG. 6, a soft magnetic material may protect and cover the base station from magnetic fields generated by the primary coils. The shielding may extend a minimum of 2 mm beyond the outer edges of the primary coils and be a minimum of 2 mm thick. The shielding may be provided below the primary coils and have a distance d_s of maximum 1.0 mm from the primary coils. The shielding may be made of manganese-zinc (MnZn) ferrite (e.g., PM12 of Todaisu).

[0067] The distance d_z (or z distance) from the top face of the primary coils to the interface surface of the base station may be about 1.1 ± 0.2 mm. The interface surface of the base station may be designed to extend a minimum of 5 mm beyond the outer edges of the primary coils.

[0068] FIG. 7 is a diagram illustrating an equivalent circuit of a power transmitter in accordance with an embodiment of the present invention.

[0069] Referring to FIG. 7, the power transmitter (or coil assembly drive circuit) in accordance with an embodiment of the present invention may use/include a full-bridge inverter (hereinafter, abbreviated as "inverter") for driving individual primary coils and a series capacitor C_p . This full-bridge inverter concept may correspond to the above-described power conversion unit or be included in it.

[0070] The coil assembly and the shielding may be designed to have a magnetic inductance L_p of about 11.3 ± 0.7 μ H (i.e., 10.6-12.0 μ H), and the series capacitor C_p may be designed to have a capacitance of about $139 \pm 6\%$ μ H (i.e., 133-147 nF).

[0071] The power transmitter (or communications & control unit) may control the input voltage applied to the inverter in order to control the amount of power transmitted to the power receiver. More particularly, the power transmitter (or communications & control unit) may control the input voltage applied to the inverter over the range of 1 V to 18 V, with a resolution of 10 mV. The inverter may operate in mid-power mode and low-power mode. The operating frequency f_{op} of the power transmitter (or coil assembly) may be substantially fixed at about 140 to 150 kHz, with a duty cycle of 50

EP 3 373 411 B1

%. As used herein, the operating frequency may mean the oscillation frequency of a voltage/power signal applied to drive/operate the power transmitter (or coil assembly). An external voltage applied to the power transmitter may range from 10 V to 14 V (generally, 12 V).

[0072] In a case where the power transmitter (or communications & control unit) transmits/applies a power signal (e.g., digital ping signal), an initial voltage of about 5.0 ± 0.5 V may be used to the bottom and top coils, and the operating frequency used may be in the range of 140 kHz to 150 kHz - for example, 145 kHz.

[0073] Control of the power transmitter (or communications & control unit) may be performed using a proportional integral differential (PID) algorithm. As used herein, the PID algorithm (or PID controller) denotes an algorithm that basically takes the form of a feedback controller, calculates an error value by measuring an output value of an object intended to be controlled and comparing the measured output value to a reference value or setpoint, and derives a control value required by using the error value.

[0074] To ensure accurate power control, the power transmitter (or communications & control unit) may determine the amplitude of primary cell current (same as primary coil current) with a resolution of about 7 mA.

[0075] Tables 1 and 2 below show parameter values that may be used in the TID algorithm.

[Table 1]

Parameter	Symbol	Value	Unit
Proportional gain	Krp	10	mA ⁻¹
Integral gain	Kri	1	mA ⁻¹ ms ⁻¹
Derivative gain	Krd	0	mA ⁻¹ ms
Integral term upper limit	Mriu	3000	N. A.
Integral term lower limit	Mril	-3000	N. A.
PID output upper limit	Mrupid	20000	N. A.
PID output lower limit	Mrlpid	-20000	N. A.
PID Scaling Factor	Krpid	100	N. A.

[Table 2]

Parameter	Symbol	Value	Unit
Proportional gain	Kdp	30	mA ⁻¹
Integral gain	Kdi	1	mA ⁻¹ ms ⁻¹
Derivative gain	Kdd	0	mA ⁻¹ ms
Integral term upper limit	Mdiu	3000	N. A.
Integral term lower limit	Mdil	-3000	N. A.
PID output upper limit	Mdupid	20000	N. A.
PID output lower limit	Mdlpid	-20000	N. A.
PID Scaling Factor	Kdpid	15	N. A.

[0076] With all of the above considered, the power transmitter (or a power transmitter circuit or the communications & control unit) in accordance with an exemplary embodiment of the present invention may control the power transferred to the power receiver by controlling the input voltage applied to the inverter. In this case, a substantially fixed operating frequency, adjustable only in the range of about 140 kHz to 150 kHz, may be used. The adjustable input voltage range is 1 V to 18 V, which is much wider than the range of input voltage applied to the inverter from other power transmitters. With this feature, the power transmitter of this invention has the following advantages and effects when used as a wireless power transmitter for a vehicle.

[0077] One of the advantages is that it is possible to prevent frequency interference with other electronic parts/equipment within the vehicle as the power transmitter operates at a fixed operating frequency. Frequency interference between the power transmitter and other electronic parts/equipment may cause safety issues critical for the driver's life and safety. Accordingly, unlike other general power transmitters, a power transmitter for a vehicle proposed in this invention may

regulate the transferred power by controlling the input voltage instead of the operating frequency.

[0078] Another advantage is that the power transmitter has a very wide adjustable input voltage range of 1 V to 18 V, and supports high input voltage, thus increasing the z distance d_z and enabling long-distance charging. This gives vehicle manufacturers a greater degree of freedom in the installation of a power transmitter in a vehicle.

[0079] As such, the power transmitter designed as shown in FIGS. 4 to 7 may be made and used as a low-power transmitter for a vehicle that enables low-power charging at about 5 W or as a medium-power transmitter for a vehicle that enables wireless power charging at about 15 W.

[0080] Now, test results of the power transfer performance of the power transmitter designed as shown in FIGS. 4 to 7 will be discussed.

[0081] FIGS. 8 and 9 show test results of the power transfer performance of a power transmitter designed in accordance with an embodiment of the present invention.

[0082] In the test of FIGS. 8 and 9, the power transmitter transferred power to the power receiver, aiming at reaching six target voltage levels a~f, and actual measurements of the voltage received by the power receiver were made. The target voltage levels for power transfer to the power receiver were set as follows:

- a: 4.2V, b: 7.0V, c: 4.2V, d: 7.5V, e: 5.0V, f: 5.0V

[0083] From the Guaranteed Power category of FIG. 8, it is demonstrated that the power transfer performance test results were pass for all the six target voltage levels a~f. More specifically, referring to FIG. 9(a) to 9(f), it is demonstrated that power was transferred to the power receiver at appropriate voltage levels, without a large deviation from the target voltage levels.

[0084] Besides, referring to FIG. 8, it is demonstrated that the power transmitter of the invention satisfies all the power transmitter specifications defined by the WPC standard.

[0085] FIGS. 10 and 11 show test results of the transmit power level adjustment function of a power transmitter designed in accordance with an embodiment of the present invention.

[0086] More specifically, FIG. 10(a), FIG. 10(b), FIG. 11(a), and FIG. 11(b) show test results of the transmit power level adjustment function of the power transmitter when the target power level is 8 W, 15 W, 12 W, and 15 W, respectively. In FIGS. 10 and 11, a "Sent Control Error: n" message indicates that the power currently received by the power receiver is n W less than the target transmit power.

[0087] Referring to the test results of FIGS. 10 and 11, the power transmitter of this invention may find out how far the current level of power being transferred to the power receiver falls below the target power level by performing communication with the power receiver, and based on this, may adjust the transmit power level to the target power level. That is, the test results of FIGS. 10 and 11 reveal that the power transmitter of this invention may adjust the transmit power level to the target power level by performing proper communication with the power receiver.

[0088] FIGS. 12 and 13 show test results of the thermal performance of a power transmitter designed in accordance with an embodiment of the present invention.

[0089] More specifically, FIG. 12 shows test results from measurements of temperature changes in a foreign object (FO) when a power transmitter designed in accordance with an embodiment of the present invention transfers low power (about 5 W) to the FO, rather than the power receiver. FIG. 13 shows test results from measurements of temperature changes in the power receiver when the power transmitter transfers low power to the power receiver.

[0090] Referring to FIG. 12, it is demonstrated that the FO temperature did not go up or it increased up to 49°C. Referring to FIG. 13, it is demonstrated that the temperature of the power receiver increased up to 32°C.

[0091] From these test results, it can be said that the power receiver or FO that receives power from the power transmitter does not rise above a specific temperature, and this allows the user to use the power transmitter of this invention without risk of explosion or fire.

[Mode for Invention]

[0092] Various embodiments have been described in the best mode for invention.

[Industrial Applicability]

[0093] The present invention may be applicable to various wireless charging technologies.

Claims

1. A wireless power transmitter (2021) configured to transfer power to a

wireless power receiver (2011), comprising:

5 a coil assembly comprising first and second bottom coils placed adjacent to each other in a line and each consisting of a single layer of 11 turns and a top coil stacked on the first and second bottom coils and consisting of a single layer of 12 turns; and
a full-bridge inverter driving each of coils included in the coil assembly individually,
wherein the first and second bottom coils and the top coil have a substantially rectangular frame structure with a through hole in the center,
10 wherein the top coil lies on a plane surface in the middle between the first and second bottom coils, and wherein a distance from the center of the first and second bottom coils to the center of the top coil is set to 23 mm, wherein the first and second bottom coils have a height of 49 mm and a width of 44 mm, and the through hole in the first and second bottom coils has a height of 26 mm and a width of 22 mm,
wherein the top coil has a height of 46 mm and a width of 49.5 mm, and the through hole in the top coil has a height of 21 mm and a width of 25.5 mm, and
15 wherein the first and second bottom coils and the top coil have a thickness of 0.9 mm to 1.3 mm, wherein a level of power transferred to the wireless power receiver (2011) by the coil assembly is controlled based on a level of input voltage applied to the full-bridge inverter, wherein the level of voltage applied to the full-bridge inverter is adjusted within a range of 1 V to 18 V, wherein an operating
20 frequency of power signals transmitted from the wireless power transmitter is fixed within a range of 140 kHz to 150 kHz, wherein the first and second bottom coils and the top coil have a same inductance value within a range of 10.6 μ H to 12.0 μ H.

25 Patentansprüche

1. Drahtloser Leistungssender (2021), der konfiguriert ist, Leistung an einen drahtlosen Leistungsempfänger (2011) zu übertragen, umfassend:

30 eine Spulenanordnung mit einer ersten und einer zweiten unteren Spule, die in einer Reihe nebeneinander angeordnet sind und jeweils aus einer einzigen Lage von 11 Windungen bestehen, und einer oberen Spule, die auf der ersten und der zweiten unteren Spule gestapelt ist und aus einer einzigen Lage von 12 Windungen besteht; und
einen Vollbrückenwechselrichter, der jede Spule der Spulengruppe einzeln antreibt,
35 wobei die erste und zweite untere Spule und die obere Spule eine im Wesentlichen rechteckige Rahmenstruktur mit einem Durchgangsloch in der Mitte aufweisen,
wobei die obere Spule auf einer ebenen Fläche in der Mitte zwischen der ersten und der zweiten unteren Spule liegt, und
wobei ein Abstand von der Mitte der ersten und zweiten unteren Spule zu der Mitte der oberen Spule auf 23
40 mm festgelegt ist,
wobei die erste und die zweite untere Spule eine Höhe von 49 mm und eine Breite von 44 mm haben und das Durchgangsloch in der ersten und zweiten unteren Spule eine Höhe von 26 mm und eine Breite von 22 mm hat,
wobei die obere Spule eine Höhe von 46 mm und eine Breite von 49,5 mm hat, und das Durchgangsloch in der oberen Spule eine Höhe von 21 mm und eine Breite von 25,5 mm hat, und

45 wobei die erste und die zweite untere Spule und die obere Spule eine Dicke von 0,9 mm bis 1,3 mm aufweisen, wobei ein Leistungspegel, der von der Spulenanordnung an den drahtlosen Leistungsempfänger (2011) übertragen wird, auf der Grundlage eines Pegels einer an den Vollbrückenwechselrichter angelegten Eingangsspannung gesteuert wird, wobei der Pegel der an den Vollbrückenwechselrichter angelegten Spannung innerhalb eines Bereichs
50 von 1 V bis 18 V eingestellt wird, wobei eine Betriebsfrequenz von von dem drahtlosen Leistungssender übertragenen Leistungssignalen in einem Bereich von 140 kHz bis 150 kHz festgelegt ist, wobei die erste und die zweite untere Spule und die obere Spule einen gleichen Induktivitätswert in einem Bereich von 10,6 μ H bis 12,0 μ H aufweisen.

55 Revendications

1. Émetteur de puissance sans fil (2021) conçu pour transférer la puissance vers un récepteur de puissance sans fil (2011), comprenant:

EP 3 373 411 B1

un ensemble bobine comprenant des première et seconde bobines inférieures adjacentes l'une de l'autre sur une ligne et chacune étant constituée d'une seule couche de 11 spires et une bobine supérieure empilée sur les première et seconde bobines inférieures et constituée d'une seule couche de 12 spires; et
5 un onduleur à pont complet entraînant chacune des bobines comprises dans l'ensemble bobine individuellement, dans lequel les première et seconde bobines inférieures et la bobine supérieure ont une structure de cadre sensiblement rectangulaire avec un trou traversant au centre,
10 dans lequel la bobine supérieure se situe sur une surface plane au centre entre les première et seconde bobines inférieures, et dans lequel une distance du centre des première et seconde bobines inférieures au centre de la bobine supérieure est définie à 23 mm,
15 dans lequel les première et seconde bobines inférieures ont une hauteur de 49 mm et une largeur de 44 mm, et le trou traversant dans les première et seconde bobines inférieures a une hauteur de 26 mm et une largeur de 22 mm,
20 dans lequel la bobine supérieure a une hauteur de 46 mm et une largeur de 49,5 mm, et le trou traversant dans la bobine supérieure a une hauteur de 21 mm et une largeur de 25,5 mm, et dans lequel les première et seconde bobines inférieures et la bobine supérieure ont une épaisseur de 0,9 mm à 1,3 mm, dans lequel un niveau de puissance transféré au récepteur de puissance sans fil (2011) par l'ensemble bobine est réglé sur la base d'un niveau de tension d'entrée appliquée à l'onduleur à pont complet, dans lequel le niveau de tension appliquée à l'onduleur à pont complet est ajusté dans une plage de 1 V à 18 V, dans lequel la fréquence de fonctionnement des signaux de puissance transmis par l'émetteur de puissance sans fil est
25 fixée dans une plage de 140 kHz à 150 kHz, dans lequel les première et seconde bobines inférieures et la bobine supérieure ont une valeur d'inductance identique dans une plage de 10,6 μ H à 12,0 μ H.

30

35

40

45

50

55

[FIG. 1]

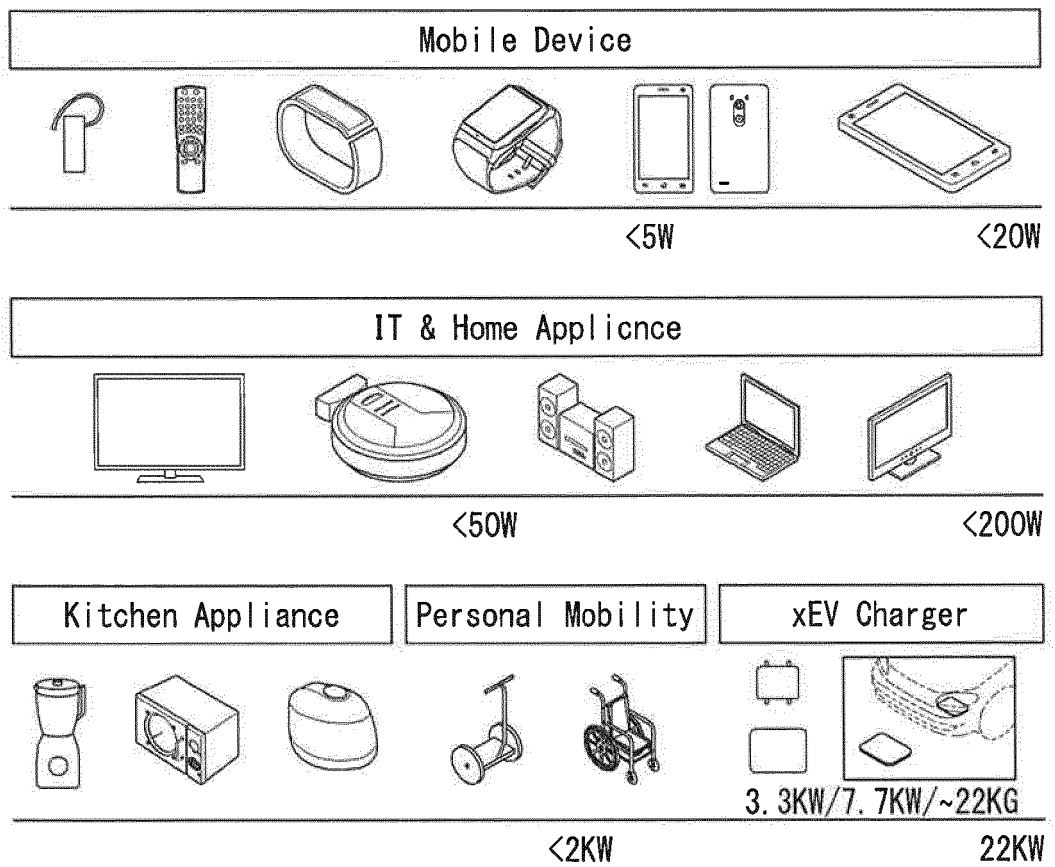

[FIG. 2]

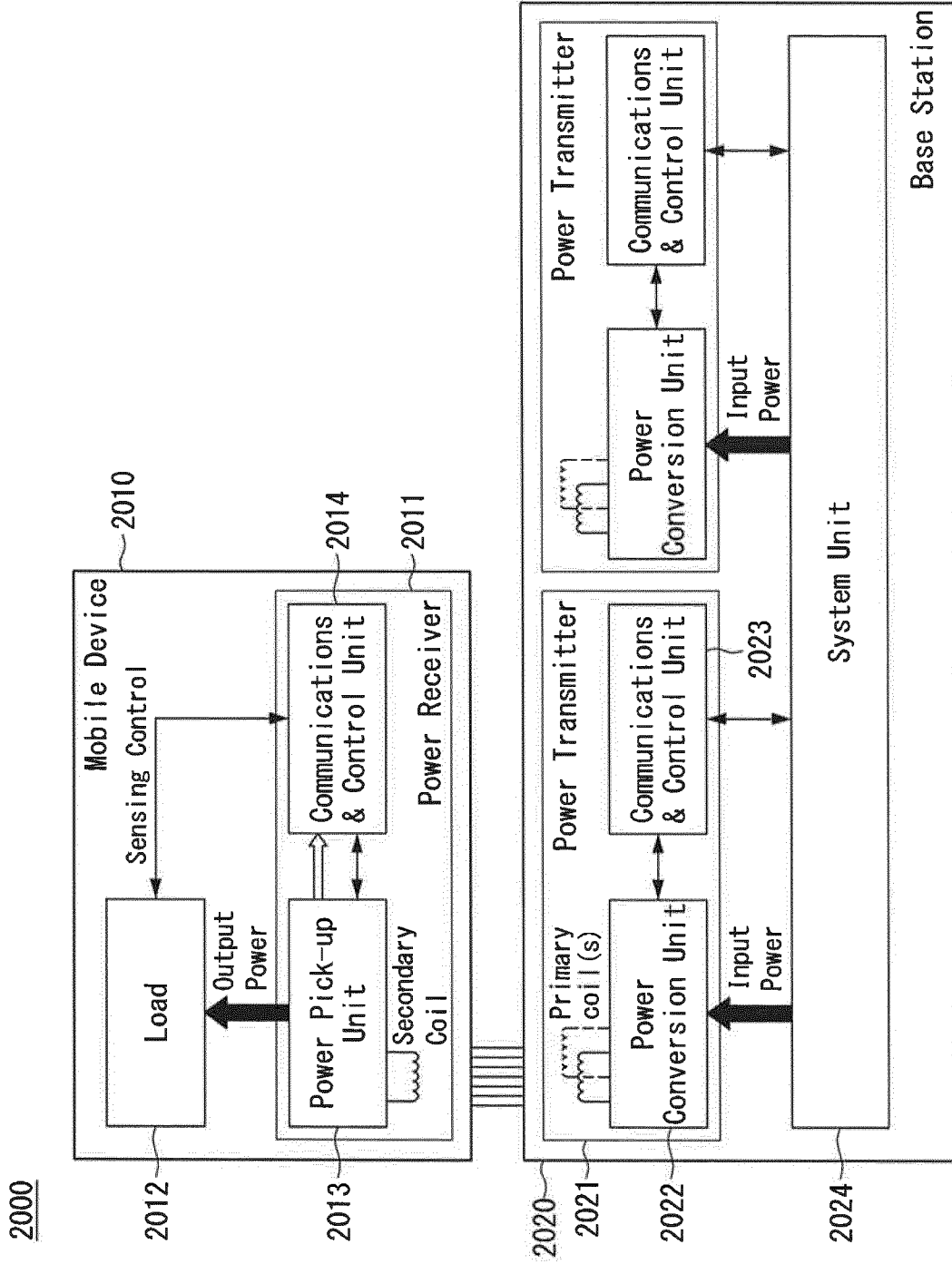

[FIG. 3]

3000

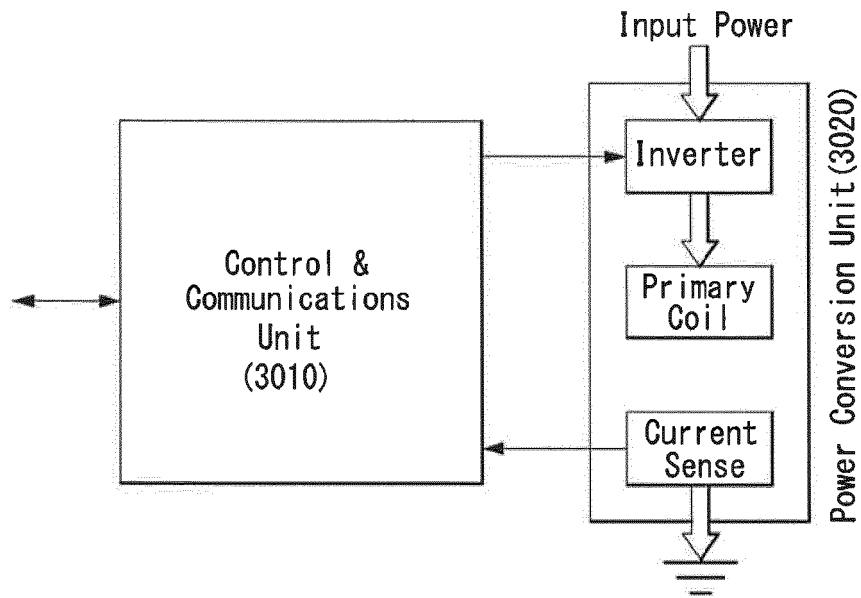

[FIG. 4]

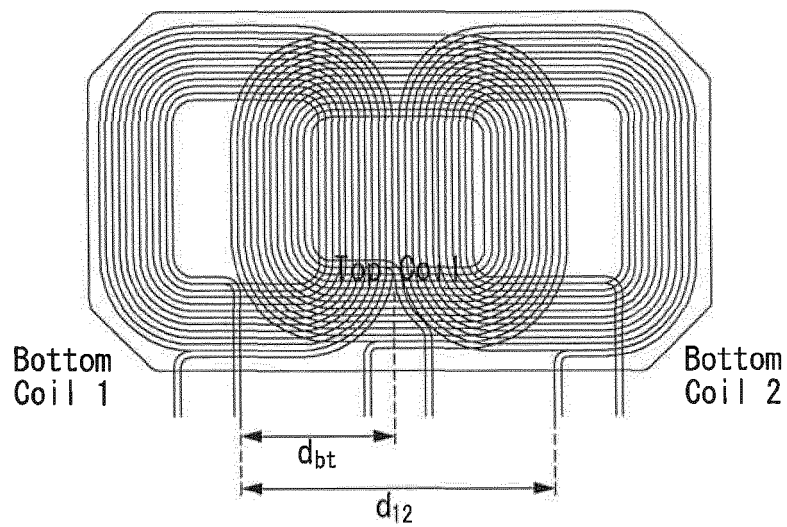

Parameter	Symbol	Value
Top coil is placed alongside from a bottom coil with a displacement	d_{bt}	$23 \pm 2 \text{mm}$
Bottom coils are placed alongside each other with a displacement	d_{12}	$46 \pm 4 \text{mm}$
Self Inductance [@1V, 100kHz] of Primary Coil	L_p	$11.3 \pm 0.7 \mu \text{H}$
Distance from the top surface of primary coil to interface surface of base-station	d_z	$5.5 \pm 1.5 \text{mm}$

[FIG. 5]

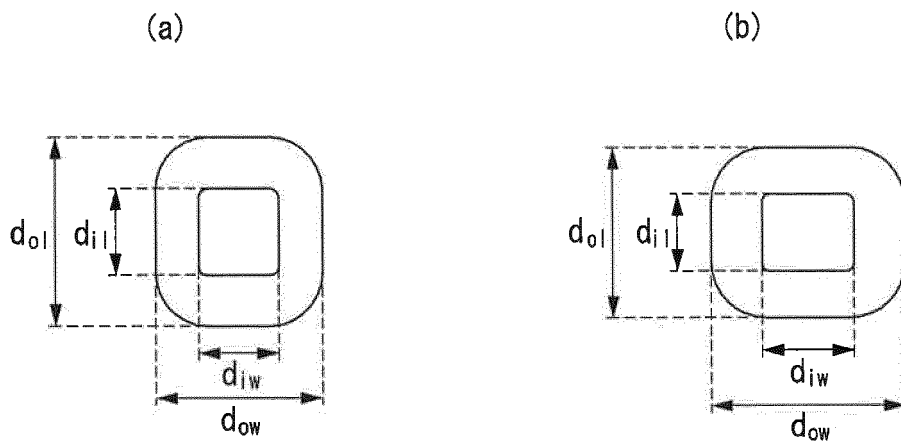

Parameter	Symbol	Value
Outer length	d_{ol}	$49.0 \pm 1.0 \text{mm}$
Inner length	d_{il}	$26.0 \pm 1.0 \text{mm}$
Outer width	d_{ow}	$44.0 \pm 1.0 \text{mm}$
Inner width	d_{iw}	$22.0 \pm 1.0 \text{mm}$
Thickness	d_c	$1.1 \pm 0.2 \text{mm}$
Number of turns per layer	N	11
Number of layers	-	1

Parameters of transmitter bottom coil
(close to ferrite)

Parameter	Symbol	Value
Outer length	d_{ol}	$46.0 \pm 1.0 \text{mm}$
Inner length	d_{il}	$21.0 \pm 1.0 \text{mm}$
Outer width	d_{ow}	$49.5 \pm 1.0 \text{mm}$
Inner width	d_{iw}	$25.5 \pm 1.0 \text{mm}$
Thickness	d_c	$1.1 \pm 0.2 \text{mm}$
Number of turns per layer	N	12
Number of layers	-	1

Parameters of transmitter top coil
(close to interface)

[FIG. 6]

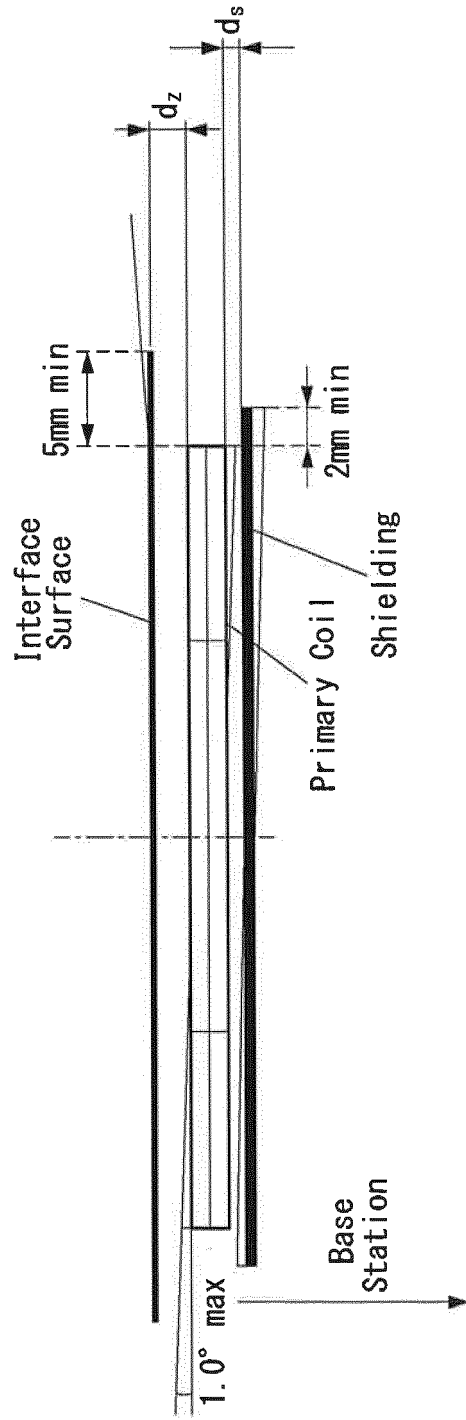

[FIG. 7]

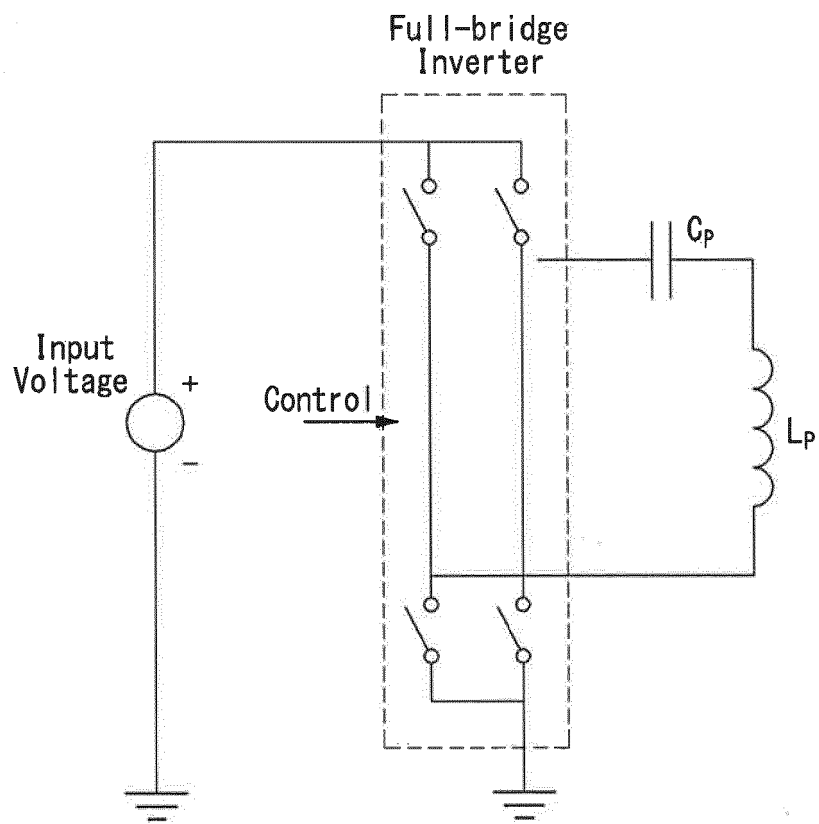

[FIG. 8a]**3.3. Summary****3.3.1. Conformance to Communication Interface****Load Modulation**

Testcase	Name	Date	Setup	Result
Req #1	Load Modulation	Oct-2015	003A	PASS

3.3.2. Conformance to System Control**Selection Phase**

Testcase	Name	Date	Setup	Result
Req #2	Interface definition requirement	Oct-2015	001A	N/A

Ping Phase

Testcase	Name	Date	Setup	Result
Req #3	a: Power Signal Characteristics	Oct-2015	001A	PASS
	b: Power Signal Characteristics	Oct-2015	001B	PASS
	c: Power Signal Characteristics	Oct-2015	001C	PASS
	d: Power Signal Characteristics	Oct-2015	001D	PASS
Req #4	No Reponse	Oct-2015	001A	PASS
Req #5	Signal Strength	Oct-2015	001A	PASS
Req #6	Termination	Oct-2015	001A	PASS
	a: Termination:	Oct-2015	001A	PASS
Req #7	a: Termination	Oct-2015	001A	PASS
	b: Termination	Oct-2015	001A	PASS
	c: Termination	Oct-2015	001A	PASS

Identification and Configuration Phase

Testcase	Name	Date	Setup	Result
Req #8	a: Packet Sequence	Oct-2015	001A	PASS
	b: Packet Sequence	Oct-2015	001A	PASS
	c: Packet Sequence	Oct-2015	001A	PASS
	d: Packet Sequence	Oct-2015	001A	PASS
Req #9	Packet Timing	Oct-2015	001A	PASS
Req #10	Packet Timing	Oct-2015	001A	N/A
Req #11	Communication Error	Oct-2015	001A	PASS
Req #12	Packet Content	Oct-2015	001A	N/A
Req #13	Packet Content	Oct-2015	001A	PASS
	a: Packet Content	Oct-2015	001A	PASS
	b: Packet Content	Oct-2015	001A	PASS
	c: Packet Content	Oct-2015	001A	PASS
Req #14	Packet Content	Oct-2015	001A	PASS
Req #15	Power Transfer Contract	Oct-2015	001A	N/A

[FIG. 8b]

Power Transfer Phase

Testcase	Name	Date	Setup	Result
Req #16	Packet Sequence	Oct-2015	001A	PASS
	a: Packet Sequence	Oct-2015	001A	PASS
	b: Packet Sequence	Oct-2015	001A	PASS
Req #17	a: Packet Timing	Oct-2015	001A	PASS
	b: Packet Timing	Oct-2015	001A	PASS
Req #18	Packet Timing	Oct-2015	001A	PASS
Req #19	Packet Content	Oct-2015	001A	N/A
Req #20	a: Power Control	Oct-2015	001B	PASS
	b: Power Control	Oct-2015	001B	PASS
Req #21	Power Control	Oct-2015	001B	PASS
Req #22	Termination	Oct-2015	001A	PASS
	a: termination	Oct-2015	001A	PASS

3.3.3. Conformance to System Performance**Guaranteed Power**

Testcase	Name	Date	Setup	Result
Req #23	a: Guaranteed Power	Oct-2015	001A	PASS
	b: Guaranteed Power	Oct-2015	001B	PASS
	c: Guaranteed Power	Oct-2015	001C	PASS
	d: Guaranteed Power	Oct-2015	001D	PASS
	e: Guaranteed Power	Oct-2015	001E	PASS
	f: Guaranteed Power	Oct-2015	TPR#6	PASS

Thermal Performance

Testcase	Name	Date	Setup	Result
Req #24	Thermal Performance	Oct-2015	002A	N/A

Foreign Object Detection

Testcase	Name	Date	Setup	Result
Req #25	a: Performance requirement	Oct-2015	TPR#5	PASS
	b: Performance requirement	Oct-2015	TPR#5	PASS
	c: Performance requirement	Oct-2015	TPR#5	PASS
	d: Performance requirement	Oct-2015	TPR#5	PASS

User Interface

Testcase	Name	Date	Setup	Result
Req #26	Object Placed	Oct-2015	001A	PASS
Req #27	Transfer In Progress	Oct-2015	001A	N/A
Req #28	Transfer Complete	Oct-2015	001A	PASS
Req #29	Fault	Oct-2015	001A	PASS
Req #30	Multiple Devices	Oct-2015	001A	N/A
Req #31	Performance requirement	Oct-2015	001A	N/A

[FIG. 9]

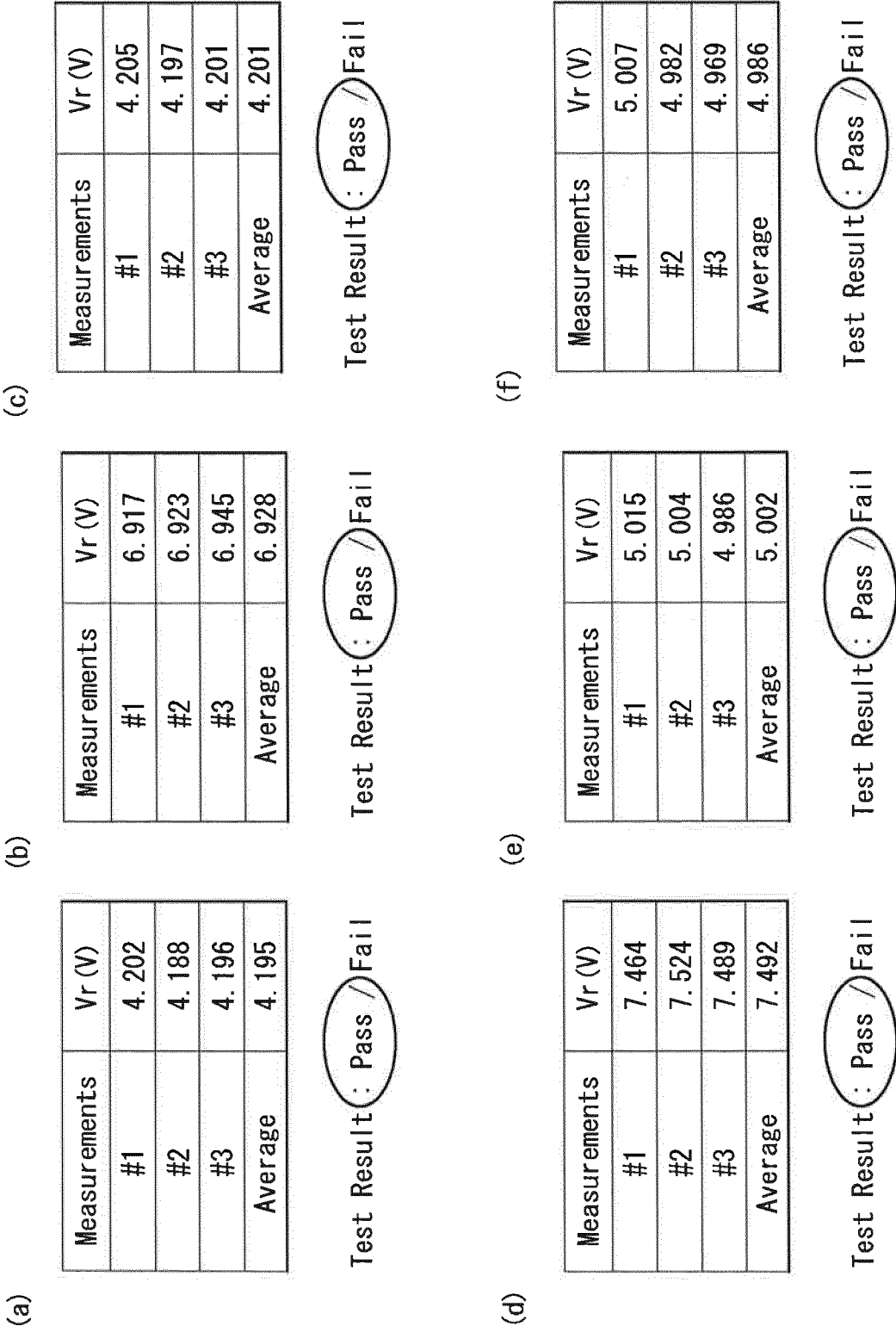

[FIG. 10a]

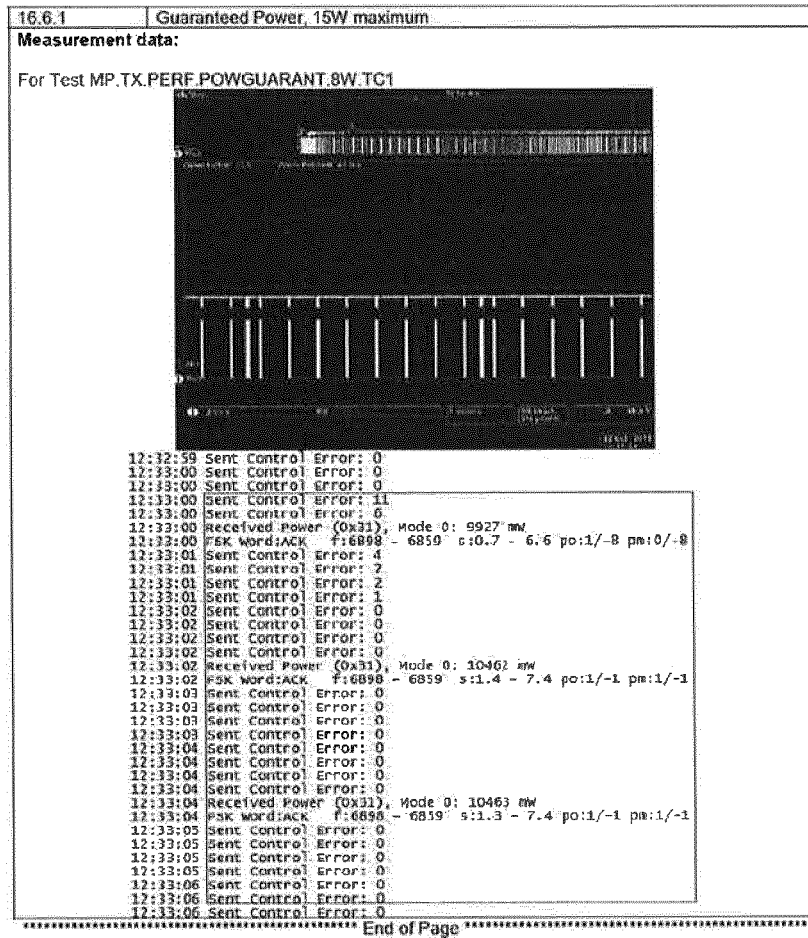

(a) 8W

[FIG. 11a]

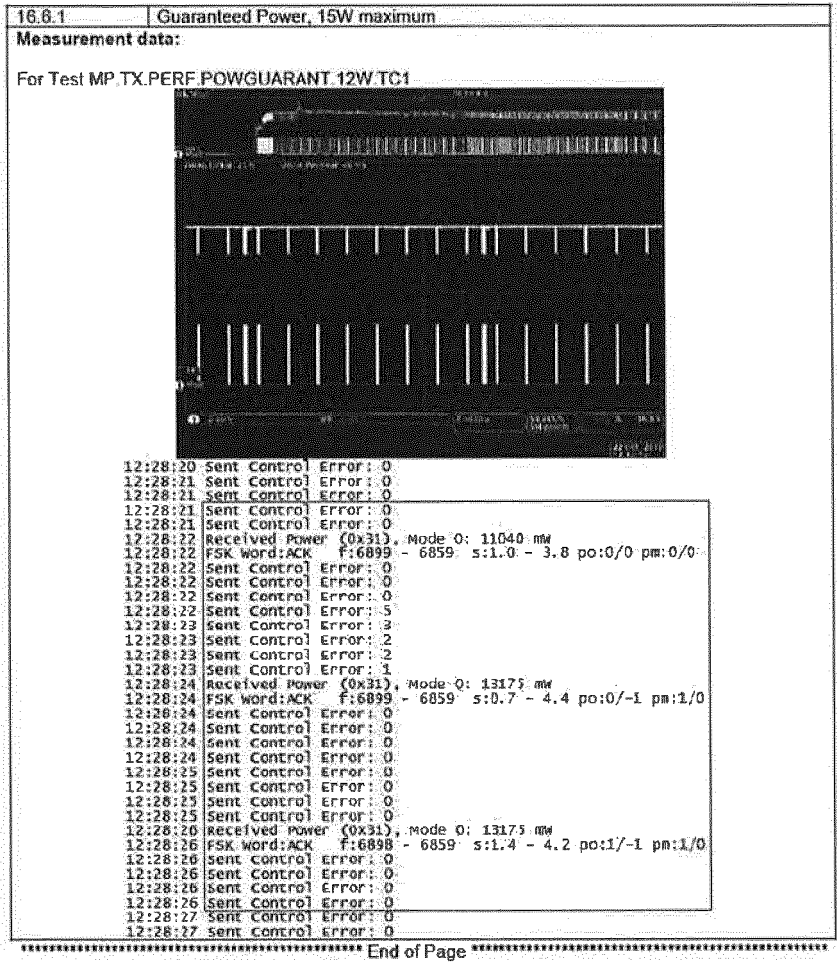

(a) 12W

[FIG. 11b]

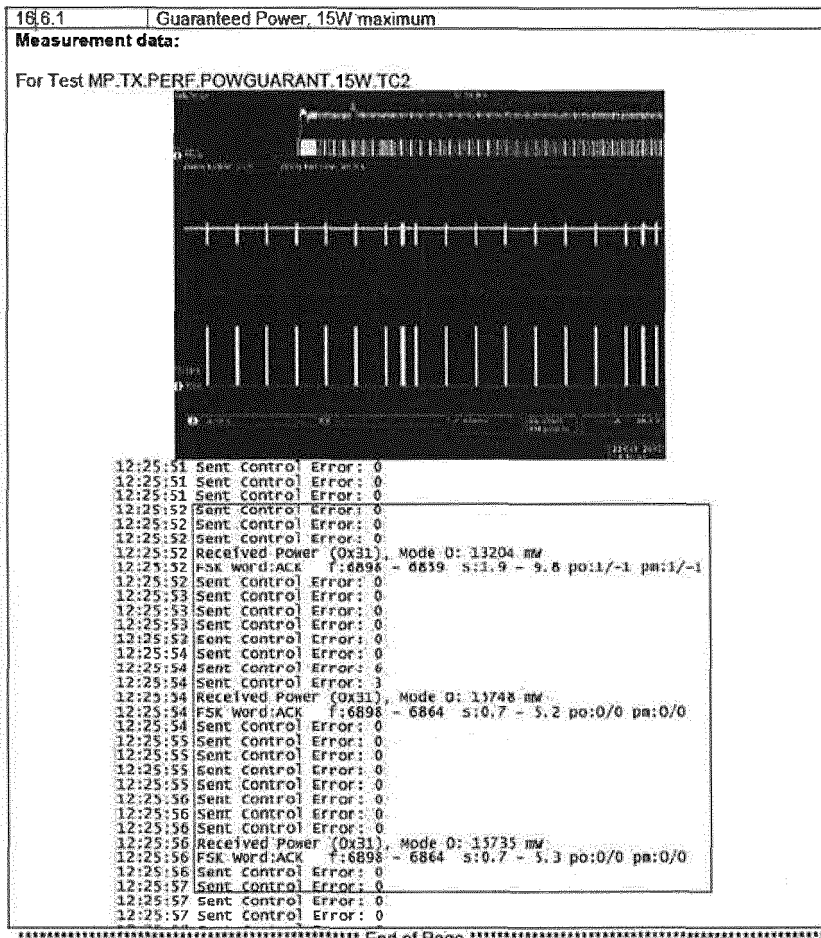

(b) 15W

[FIG. 12]

	Distance	F0 Temp.	Criteria
Test #25 (a)	0 mm	45°C	≤ 60°C
	2 mm	49°C	
	5 mm	No charging	
Test #25 (b)	0 mm	44°C	≤ 60°C
	2 mm	48°C	
	5 mm	No charging	
Test #25 (c)	0 mm	No charging	≤ 60°C
	2 mm	No charging	
	5 mm	No charging	
Test #25 (d)	0 mm	No charging	≤ 80°C
	2 mm	No charging	
	5 mm	No charging	

Test Result: Pass / Fail

[FIG. 13]

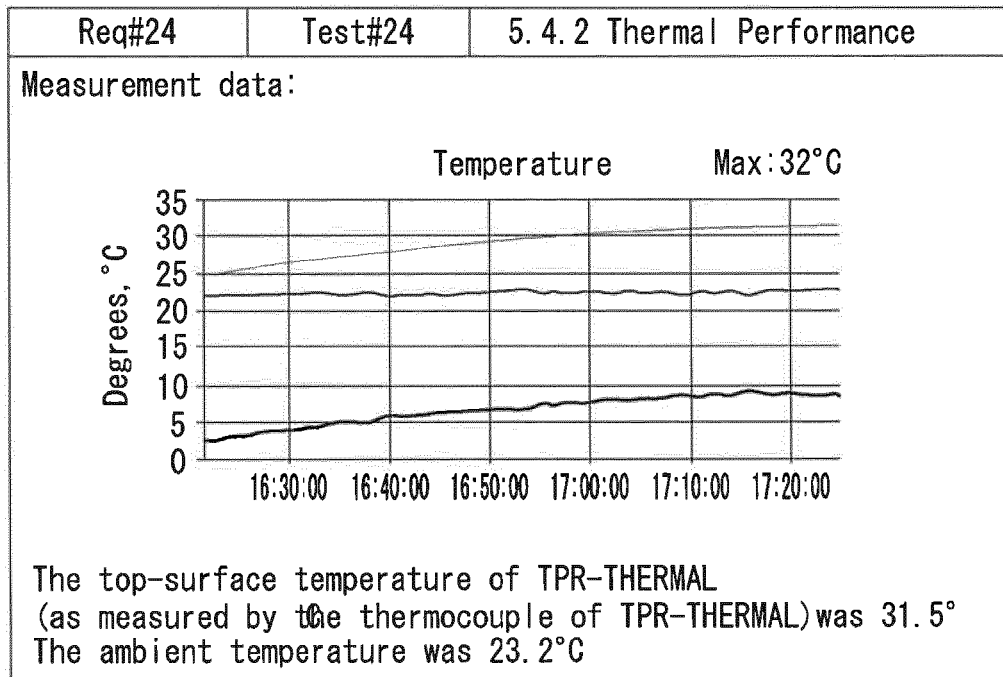

Test Result : Pass / Fail

REFERENCES CITED IN THE DESCRIPTION

This list of references cited by the applicant is for the reader's convenience only. It does not form part of the European patent document. Even though great care has been taken in compiling the references, errors or omissions cannot be excluded and the EPO disclaims all liability in this regard.

Patent documents cited in the description

- US 2014070622 A1 [0003]
- KR 20150093588 A [0004]
- CN 202695109 U [0005]