

(19)



(11)

EP 3 392 028 B1

(12)

EUROPEAN PATENT SPECIFICATION

(45) Date of publication and mention of the grant of the patent:
30.08.2023 Bulletin 2023/35

(21) Application number: **18168622.1**

(22) Date of filing: **20.04.2018**

(51) International Patent Classification (IPC):
B29C 70/70 (2006.01) C08L 75/00 (2006.01)

(52) Cooperative Patent Classification (CPC):
(C-Sets available)
D07B 1/162; C08L 75/00; B29C 48/154;
B29D 29/00; B29K 2483/00; B29K 2995/0016;
D07B 1/16; D07B 1/22; D07B 2201/2087;
D07B 2201/2092; D07B 2401/2035;
D07B 2501/2007

(Cont.)

(54) POLYMER JACKET MATERIAL BLENDS WITH IMPROVED FLAME RESISTANCE

POLYMERMANTELMATERIALMISCHUNGEN MIT VERBESSERTER FLAMMWIDRIGKEIT

MÉLANGES DE MATÉRIAUX DE VESTE POLYMÈRE PRÉSENTANT UNE RÉSISTANCE ACCRUE AUX FLAMMES

(84) Designated Contracting States:
AL AT BE BG CH CY CZ DE DK EE ES FI FR GB GR HR HU IE IS IT LI LT LU LV MC MK MT NL NO PL PT RO RS SE SI SK SM TR

(30) Priority: **20.04.2017 US 201762487688 P**

(43) Date of publication of application:
24.10.2018 Bulletin 2018/43

(73) Proprietor: **Otis Elevator Company Farmington, Connecticut 06032 (US)**

(72) Inventors:
• **PAPAS, Paul East Hartford, CT Connecticut 06108 (US)**
• **ZAFIRIS, Georgios S East Hartford, CT Connecticut 06108 (US)**

• **GUILANI, Brad Farmington, CT Connecticut 06032 (US)**

(74) Representative: **Dehns St. Bride's House 10 Salisbury Square London EC4Y 8JD (GB)**

(56) References cited:
US-A1- 2014 015 168 US-A1- 2014 308 505

EP 3 392 028 B1

Note: Within nine months of the publication of the mention of the grant of the European patent in the European Patent Bulletin, any person may give notice to the European Patent Office of opposition to that patent, in accordance with the Implementing Regulations. Notice of opposition shall not be deemed to have been filed until the opposition fee has been paid. (Art. 99(1) European Patent Convention).

(52) Cooperative Patent Classification (CPC): (Cont.)

C-Sets

C08L 75/00, C08L 67/06, C08L 83/04

Description

BACKGROUND

[0001] There are various uses for elongated flexible assemblies such as for elevator load bearing members or roping arrangements, drive belts for machines such as a passenger conveyor and handrails for passenger conveyors, for example. Such assemblies may be designed with fire resistance performance in order to meet existing building codes or lower flammability related risks. Such assemblies must also meet mechanical performance requirements. US 2014/308505 A1 discloses a composition comprising a thermoplastic polyamide and furthermore a phosphonate containing polymer. Moreover, it discloses the possible use of further fire resistant additives, such as siloxanes. US 2014/308505 A1 also discloses that the compositions can be used in the manufacture of conveyor belts.

[0002] US 2014/015168 A1 discloses a material of a polymer jacket in the event of high temperature conditions such as during a fire. Claim 1 of US 2014/015168 A1 relates to a method of making an assembly having at least one elongated cord tension member at least partially covered by a polymer jacket, comprising the steps of: mixing a polymer base resin and a melamine-based geometry stabilizer to provide a batch of mixed material; compounding said batch of mixed material with a polymer material to provide a batch of jacket material; and forming the jacket material into a desired shape of the jacket. US 2014/015168 A1 specifies that the geometry stabilizer is a melamine-phosphate or melamine-polyphosphate.

SUMMARY

[0003] A fire-resistant material according to an example of the present disclosure includes a base material, a siloxane polymer and a phosphonate polymer. The siloxane polymer comprises at least one of a polyimide siloxane copolymer, polyetherimide siloxane copolymer, polyetherimide sulfone siloxane copolymer, polyimide polysiloxane block copolymers, polyetherimide polysiloxane block copolymers, polyetherimide sulfone polysiloxane block copolymer, and copolymers and blends thereof.

[0004] In a further embodiment of any of the foregoing embodiments, 1% to 20% by weight of the fire-resistant material is the siloxane polymer and 1% to 20% by weight of the fire-resistant material is the phosphonate polymer.

[0005] In a further embodiment of any of the foregoing embodiments, 5% to 15% by weight of the fire-resistant material is the siloxane polymer and 5% to 15% by weight of the fire-resistant material is the phosphonate polymer.

[0006] In a further embodiment of any of the foregoing embodiments, the phosphonate polymer comprises at least one of poly-phosphonate homopolymer, phosphonate oligomer, phosphonate carbonate co-oligomer, poly-phosphonate-polycarbonate copolymer, phosphonate

ester co-oligomer, and poly-phosphonate-polyester copolymer and blends thereof.

[0007] In a further embodiment of any of the foregoing embodiments, the base material is compressible.

[0008] In a further embodiment of any of the foregoing embodiments, the base material comprises at least one of a thermoplastic elastomer, a thermosetting elastomer, and a rubber polymer.

[0009] In a further embodiment of any of the foregoing embodiments, the base material is thermoplastic polyurethane.

[0010] In a further embodiment of any of the foregoing embodiments, the material is shaped into an elevator drive belt.

[0011] A belt according to an example of the present disclosure includes at least one tension member, and a jacket at least partially covering the at least one tension member. The jacket includes a fire-resistant material that has a base material, a siloxane polymer and a phosphonate-based additive. The siloxane polymer comprises at least one of a polyimide siloxane copolymer, polyetherimide siloxane copolymer, polyetherimide sulfone siloxane copolymer, polyimide polysiloxane block copolymers, polyetherimide polysiloxane block copolymers, polyetherimide sulfone polysiloxane block copolymer, and copolymers and blends thereof.

[0012] In a further embodiment of any of the foregoing embodiments, the tension members comprise wound metallic cords.

[0013] In a further embodiment of any of the foregoing embodiments, the wound metallic cords comprise steel.

[0014] In a further embodiment of any of the foregoing embodiments, the tension members comprise a polymer matrix composite. The polymer matrix composite has fibers in a matrix material.

[0015] In a further embodiment of any of the foregoing embodiments, the fibers comprise at least one of carbon, glass, mineral, liquid crystal, and aramid fibers.

[0016] In a further embodiment of any of the foregoing embodiments, the matrix material comprises at least one of polyurethane, epoxy, bis-maleimide, phenolic, polyimide, polyester, and silicone matrix composites, or mixtures and blends thereof.

[0017] In a further embodiment of any of the foregoing embodiments, 1% to 20% by weight of the fire-resistant material is the siloxane polymer and 1% to 20% by weight of the fire-resistant material is the phosphonate polymer.

[0018] In a further embodiment of any of the foregoing embodiments, the phosphonate polymer comprises at least one of poly-phosphonate homopolymer, phosphonate oligomer, phosphonate carbonate co-oligomer, poly-phosphonate-polycarbonate copolymer, phosphonate ester co-oligomer, and poly-phosphonate-polyester copolymer and blends thereof.

[0019] In a further embodiment of any of the foregoing embodiments, the base material comprises at least one of a thermoplastic elastomer, a thermosetting elastomer, and a rubber polymer.

[0020] A method of making a fire-resistant article according to an example of the present disclosure includes combining a base material with a siloxane polymer and a phosphonate polymer in extrusion equipment, and extruding the combined base material, siloxane polymer, and/or phosphonate polymer to form a fire-resistant article. The siloxane polymer comprises at least one of a polyimide siloxane copolymer, polyetherimide siloxane copolymer, polyetherimide sulfone siloxane copolymer, polyimide polysiloxane block copolymers, polyetherimide polysiloxane block copolymers, polyetherimide sulfone polysiloxane block copolymer, and copolymers and blends thereof.

[0021] In a further embodiment of the foregoing method, the fire-resistant article comprises a jacket for a belt.

[0022] A further embodiment of any of the foregoing methods includes the step of encasing at least one tension member in the jacket material.

[0023] A further embodiment of any of the foregoing methods includes providing the siloxane polymer material to the extrusion equipment in a finely ground form.

[0024] A further embodiment of any of the foregoing methods includes providing the siloxane polymer material to the extrusion equipment while the base material is in a molten form.

[0025] In a further embodiment of any of the foregoing methods, the article is at least one of an elevator belt, a passenger conveyor handrail, and a drive belt.

[0026] The various features and advantages of this invention will become apparent to those skilled in the art from the following detailed description. The drawings that accompany the detailed description can be briefly described as follows.

BRIEF DESCRIPTION OF THE DRAWINGS

[0027]

Figure 1 schematically illustrates selected portions of an elevator system including a load bearing member designed according to an embodiment of this invention.

Figure 2 is an end view schematically showing one example elevator load bearing member assembly.

Figure 3 is an end view schematically illustrating another example elevator load bearing assembly.

Figure 4 diagrammatically illustrates a passenger conveyor including a drive belt and a handrail designed according to an embodiment of this invention. Figure 5 schematically shows an example drive belt configuration.

Figure 6 schematically shows an example handrail configuration.

Figure 7 schematically illustrates an example method of making an assembly designed according to an embodiment of this invention.

DETAILED DESCRIPTION

[0028] Figure 1 schematically shows selected portions of an example elevator system 20. An elevator car 22 and counterweight 24 are suspended by a load bearing assembly 26. In one example, the load bearing assembly 26 comprises a plurality of flat belts. In another example, the load bearing assembly 26 comprises a plurality of round ropes.

[0029] The load bearing assembly 26 supports the weight of the elevator car 22 and the counterweight 24 and facilitates movement of the elevator car 22 into desired positions by moving along sheaves 28 and 30. One of the sheaves will be a traction sheave that is moved by an elevator machine in a known manner to cause the desired movement and placement of the elevator car 22. The other sheave in this example is an idler sheave.

[0030] Figure 2 is an end view schematically showing one example flat belt configuration included as part of the example load bearing assembly 26. In this example, the flat belt includes a plurality of elongated cord tension members 32 and a polymer jacket 34 that contacts the tension members 32. In this example, the jacket 34 encases the tension members 32. In one example, the tension members 32 comprise wound metallic cords, such as steel. In another example, the tension members 32 comprise a polymer matrix composite including, for instance, fibers in a matrix material. Example fibers include but are not limited to carbon-, glass-, mineral-, liquid crystal-, and aramid-fibers. Example matrix materials include but are not limited to polyurethane, epoxy, bis-maleimide, phenolic, polyimide, polyester, and silicone matrix composites, or mixtures and blends thereof. The polymer jacket 34 in one example comprises a thermoplastic elastomer. In one example, the jacket 34 comprises a thermoplastic polyurethane. In another embodiment, the jacket 34 comprises a thermoplastic or thermosetting elastomer polymer (including polyurethane) or rubber polymer or mixtures and blends thereof.

[0031] Another example is schematically shown in Figure 3. An end view of a rope used as part of the load bearing assembly 26 includes at least one tension member 32 and a polymer jacket 34. In the example of Figure 3, the same materials can be used as those mentioned above.

[0032] Figure 4 schematically illustrates an example passenger conveyor 40. In this example, a plurality of steps 42 move in a known manner to carry passengers between landings 44 and 46. A handrail 48 is provided for passengers to grab onto while traveling on the conveyor 40.

[0033] As shown in Figure 6, the handrail 48 includes a plurality of tension members 32 such as steel cords or polymer matrix composite tension elements or members at least partially covered by a polymer jacket 34. The polymer jacket in this example establishes the gripping surface and the body of the handrail 48.

[0034] The example of Figure 4 also includes a drive

arrangement 50 for propelling the steps 42 in a desired direction. A motor 52 rotates a drive sheave 54 to cause movement of a drive belt 56. As shown in Figure 5, the example drive belt 56 has a plurality of elongated cord tension members 32 covered by a jacket 34. The jacket material establishes teeth 57 that interact with a corresponding surface on the drive sheave 54. A step chain 58 (Figure 4) is engaged by teeth 59 on the drive belt 56 to cause the desired movement of the steps 42. In this example, the teeth 57 and 59 are on oppositely facing sides of the drive belt 56.

[0035] When a metal is used for the any of the example tension members 32, the metal material may be uncoated, coated, or plated with a protective metal. For example, a base ferrous metal may be coated or plated with zinc, tin or copper. In another embodiment, when a polymer matrix composite is used for the any of the example tension members 32, the polymer matrix composite material may be uncoated or coated or blended with an additive that promotes adhesion between said polymer matrix composite and the elastomer or rubber polymer jacket 34. The additive can include at least one of but not limited to poly-phosphonate homopolymer, phosphonate oligomer, phosphonate carbonate co-oligomer, poly-phosphonate-polycarbonate copolymer, phosphonate ester co-oligomer, and poly-phosphonate-polyester copolymer and blends thereof.

[0036] In each of the above example assemblies, the jacket material includes one or more additives promoting flame resistance. The jacket material in the illustrated embodiment includes a base material blended with at least one of a siloxane polymer and a phosphonate polymer or blends and mixtures thereof. The base material is one of a thermoplastic or thermosetting elastomer and rubber polymer. In one example, the jacket material is elastic. For instance, the base material can comprise an elastomer such as polyurethane.

[0037] Example phosphonate polymers include at least one of but are not limited to poly-phosphonate homopolymer, phosphonate oligomer, phosphonate carbonate co-oligomer, poly-phosphonate-polycarbonate copolymer, phosphonate ester co-oligomer, and poly-phosphonate-polyester copolymer and blends thereof. The siloxane polymer includes at least one of a polyimide siloxane copolymers, polyetherimide siloxane copolymers, polyetherimide sulfone siloxane copolymers, polyimide polysiloxane block copolymers, polyetherimide polysiloxane block copolymers, polyetherimide sulfone polysiloxane block copolymers, and copolymers and blends thereof.

[0038] The combination of the siloxane polymer and the phosphonate -based polymer provides a flame retardant or fire resistant synergistic effect. For example, in case of fire, the combination of a siloxane polymer and a phosphonate -based polymer reduces burning or flame spread as well as molten dripping of the jacket material in a non-linear manner. Reducing molten dripping inhibits fire propagation and ignition of adjacent materials in the

elevator hoistway or building structure surrounding a passenger conveyor. While addition of a siloxane polymer alone or a phosphonate polymer alone provides fire-resistance, the combination of them surprisingly also reduces dripping of the jacket material if exposed to fire or high heat conditions.

[0039] Furthermore, addition of siloxane polymers improve controlled slip and traction performance of the thermoplastic jacket material over time, eliminating the need for low molecular weight wax additives. Such wax additives may introduce variability in the performance of the material and ultimately high scrap rates and increased cost due to manufacturing variations. Eliminating or reducing such additives therefore enhances manufacturing yield and provides cost savings with increased performance and reliability.

[0040] The above phosphonate and siloxane polymers are free from halogens such that toxic gas is not a concern should the jacket material burn.

[0041] The siloxane polymer in some example embodiments comprises a siloxane polyetherimide block copolymer like Ultem™ Resin SILTEM-STM1500 or STM1700 or STM 1600 (manufactured by Saudi Basic Industries Corporation). The phosphonate polymer in some example embodiments comprises a polyphosphonate polymer or oligomer, such as Nofia® HM1100, OL5000, OL3000, OL3001, OL5001 (FRX Polymers, Inc.)

[0042] The siloxane and phosphonate polymers added to the jacket material are melt-extrudable and are melt-blended with the thermoplastic base of the jacket material. In some examples, the ideal melt processing temperature of the polymers in the jacket material are substantially similar to the ideal melt processing temperatures of the thermoplastic base material. In other examples the melt processing temperature of one of the above polymers may differ from the ideal melt processing temperature of the base material or the other polymer, and in this case it is added initially as a powder grind. In yet another example one or both of the polymers may be added to the base elastomer or rubber material in solution form in a common solvent, which is then evaporated upon processing to form the final solid belt or handrail article. In this latter case one or more the polymers and base materials can be in solution form in a common solvent.

[0043] In some embodiments, each of the additive polymers in the jacket material comprise less than about 50% of the total jacket material composition. More specifically, the jacket material can include both siloxane and phosphonate additive polymers, each comprising less than about 50% by weight of the total jacket material composition. Because a low amount of additive polymers is required to achieve the desired fire resistance characteristics, the mechanical properties of the thermoplastic jacket material (including abrasion resistance, tensile strength, and tear strength) are not significantly affected.

[0044] In one particular example, the jacket material 34 comprises a thermoplastic polyurethane, about 1-20% by weight of Nofia® HM1100 or OL5000 or

OL3000, or OL3001, or OL5001 (FRX Polymers, Inc.), and about 1-20% by weight Ultem™ Resin SILTEM STM1500 or STM1600 or STM1700 (Saudi Basic Industries Corporation).

[0045] In a different example, the jacket material comprises an ether-based thermoplastic polyurethane, such as Elastollan® 1195 (BASF SE), and about 5-15% by weight of each of Nofia® HM1100 or OL5000 (FRX Polymers, Inc.) and Ultem™ Resin SILTEM STM1500 or STM1600 or STM1700 (Saudi Basic Industries Corporation). This example achieves a UL1581 FT1 fire resistance rating of the load bearing assembly 26.

[0046] In other embodiments, the jacket material is formed solely of a combination of the siloxane polymer and the phosphonate polymer, or a combination of elastomer or rubber base material and siloxane and phosphonate polymers discussed above.

[0047] Figure 7 schematically shows an example method 60 for making a fire-resistant article, such as a load-bearing belt or rope, a handrail, or a drive belt. A selected siloxane polymer material 62 such as those mentioned above, a selected phosphonate polymer material 64 such as those mentioned above, and a selected base material 66 such as the thermoplastic elastomer or rubber polymer base materials discussed above are provided to extrusion equipment 68. In one example, the siloxane polymer material 62 is in finely ground form prior to being provided to the extrusion equipment 68. In another example, the siloxane polymer material 62 is heated and provides a molten form of the siloxane polymer material to the extrusion equipment 68. In a third example, one or both of the polymers 62, 64 are provided to the extrusion equipment 68 while the thermoplastic base material is in molten form. In yet another example, the phosphonate polymer 64, the siloxane polymer 62, and the base material 66 are pre-compounded into a single material using single or twinscrew extrusion process and then fed directly to the jacket forming station 70.

[0048] The jacket material is formed into a desired shape as it exits the extrusion equipment 68 in a jacket forming station 70, or both. For instance, a plurality of spools 72 supply tension members 32 to the jacket forming station 70 and the jacket is extruded or molded onto at least one exterior surface of the tension members 32 resulting in the desired assembly. In the case of Figure 7, the resulting assembly is an elevator load bearing belt 26.

[0049] The scope of legal protection given to this invention can only be determined by studying the following claims.

Claims

1. A fire-resistant material, comprising:

a base material, a siloxane polymer and a phosphonate polymer,

wherein the siloxane polymer comprises at least one of a polyimide siloxane copolymer, polyetherimide siloxane copolymer, polyetherimide sulfone siloxane copolymer, polyimide polysiloxane block copolymers, polyetherimide polysiloxane block copolymers, polyetherimide sulfone polysiloxane block copolymer, and copolymers and blends thereof.

2. The fire-resistant material of claim 1, wherein 1% to 20% by weight of the fire-resistant material is the siloxane polymer and 1% to 20% by weight of the fire-resistant material is the phosphonate polymer, preferably wherein 5% to 15% by weight of the fire-resistant material is the siloxane polymer and 5% to 15% by weight of the fire-resistant material is the phosphonate polymer.

3. The fire-resistant material of claim 1 or 2, wherein the phosphonate polymer comprises at least one of poly-phosphonate homopolymer, phosphonate oligomer, phosphonate carbonate co-oligomer, poly-phosphonate-polycarbonate copolymer, phosphonate ester co-oligomer, and poly-phosphonate-polyester copolymer and blends thereof.

4. The fire-resistant material of any preceding claim, wherein the base material is compressible.

5. The fire-resistant material of any preceding claim, wherein the base material comprises at least one of a thermoplastic elastomer, a thermosetting elastomer, and a rubber polymer, and optionally wherein the base material is thermoplastic polyurethane.

6. The fire-resistant material of any preceding claim, wherein the material is shaped into an elevator drive belt.

7. A belt, comprising:

at least one tension member; and
a jacket at least partially covering the at least one tension member, the jacket comprising a fire-resistant material including a base material, a siloxane polymer and a phosphonate-based additive,

wherein the siloxane polymer comprises at least one of a polyimide siloxane copolymer, polyetherimide siloxane copolymer, polyetherimide sulfone siloxane copolymer, polyimide polysiloxane block copolymers, polyetherimide polysiloxane block copolymers, polyetherimide sulfone polysiloxane block copolymer, and copolymers and blends thereof.

8. The belt of claim 7, wherein the tension members comprise wound metallic cords, and optionally

wherein the wound metallic cords comprise steel.

9. The belt of claim 7 or 8, wherein the tension members comprise a polymer matrix composite, the polymer matrix composite including fibers in a matrix material, and optionally wherein the fibers comprise at least one of carbon, glass, mineral, liquid crystal, and aramid fibers, and/or optionally wherein the matrix material comprises at least one of polyurethane, epoxy, bis-maleimide, phenolic, polyimide, polyester, and silicone matrix composites, or mixtures and blends thereof.
10. The belt of any of claims 7-9, wherein 1% to 20% by weight of the fire-resistant material is the siloxane polymer and 1% 20% by weight of the fire-resistant material is the phosphonate polymer.
11. The belt of any of claims 7-10, wherein the phosphonate polymer comprises at least one of poly-phosphonate homopolymer, phosphonate oligomer, phosphonate carbonate co-oligomer, poly-phosphonate-polycarbonate copolymer, phosphonate ester co-oligomer, and poly-phosphonate-polyester copolymer and blends thereof.
12. The belt of any of claims 7-11, wherein the base material comprises at least one of a thermoplastic elastomer, a thermosetting elastomer, and a rubber polymer.
13. A method of making a fire-resistant article, wherein optionally the article is at least one of:
- an elevator belt;
 - a passenger conveyor handrail, and
 - a drive belt;
- the method comprising:
- combining a base material with a siloxane polymer and a phosphonate polymer in extrusion equipment; and
 - extruding the combined base material, siloxane polymer, and phosphonate polymer to form a fire-resistant article;
 - wherein the siloxane polymer comprises at least one of a polyimide siloxane copolymer, polyetherimide siloxane copolymer, polyetherimide sulfone siloxane copolymer, polyimide polysiloxane block copolymers, polyetherimide polysiloxane block copolymers, polyetherimide sulfone polysiloxane block copolymer, and copolymers and blends thereof.
14. The method of claim 13, wherein the fire-resistant article comprises a jacket for a belt, and optionally further comprising the step of encasing at least one

tension member in the jacket material.

15. The method of claim 13 or 14, comprising providing the siloxane polymer material to the extrusion equipment in a finely ground form, and optionally comprising providing the siloxane polymer material to the extrusion equipment while the base material is in a molten form.

Patentansprüche

1. Feuerbeständiges Material, umfassend:
- ein Basismaterial, ein Siloxanpolymer und ein Phosphonatpolymer,
 - wobei das Siloxanpolymer mindestens eines von einem Polyimid-Siloxan-Copolymer, einem Polyetherimid-Siloxan-Copolymer, einem Polyetherimid-Sulfon-Siloxan-Copolymer, Polyimid-Polysiloxan-Blockcopolymeren, Polyetherimid-Polysiloxan-Blockcopolymeren, einem Polyetherimid-Sulfon-Polysiloxan-Blockcopolymer und Copolymeren und Mischungen davon umfasst.
2. Feuerbeständiges Material nach Anspruch 1, wobei 1 bis 20 Gew.-% des feuerbeständigen Materials das Siloxanpolymer sind und 1 bis 20 Gew.-% des feuerbeständigen Materials das Phosphonatpolymer sind,
- wobei bevorzugt 5 bis 15 Gew.-% des feuerbeständigen Materials das Siloxanpolymer sind und 5 bis 15 Gew.-% des feuerbeständigen Materials das Phosphonatpolymer sind.
3. Feuerbeständiges Material nach Anspruch 1 oder 2, wobei das Phosphonat-Polymer mindestens eines von einem Polyphosphonat-Homopolymer, einem Phosphonat-Oligomer, einem Phosphonat-Carbonat-Cooligomer, einem Polyphosphonat-Polycarbonat-Copolymer, einem Phosphonat-Ester-Cooligomer und einem Polyphosphonat-Polyester-Copolymer und Mischungen davon umfasst.
4. Feuerbeständiges Material nach einem der vorhergehenden Ansprüche, wobei das Basismaterial komprimierbar ist.
5. Feuerbeständiges Material nach einem der vorhergehenden Ansprüche, wobei das Basismaterial mindestens eines von einem thermoplastischen Elastomer, einem duroplastischen Elastomer und einem Kautschukpolymer umfasst und wobei optional das Basismaterial thermoplastisches Polyurethan ist.
6. Feuerbeständiges Material nach einem der vorhergehenden Ansprüche, wobei das Material zu einem

Aufzugsantriebsriemen geformt ist.

7. Riemen, umfassend:

mindestens ein Zugelement; und
einen Mantel, der das mindestens eine Zugelement mindestens teilweise abdeckt, wobei der Mantel ein feuerbeständiges Material umfasst, das ein Basismaterial, ein Siloxanpolymer und ein Additiv auf Phosphonatbasis beinhaltet, wobei das Siloxanpolymer mindestens eines von einem Polyimid-Siloxan-Copolymer, einem Polyetherimid-Siloxan-Copolymer, einem Polyetherimid-Sulfon-Siloxan-Copolymer, Polyimid-Polysiloxan-Blockcopolymeren, Polyetherimid-Polysiloxan-Blockcopolymeren, einem Polyetherimid-Sulfon-Polysiloxan-Blockcopolymer und Copolymeren und Mischungen davon umfasst.

8. Riemen nach Anspruch 7, wobei die Zugelemente gewickelte Metallschnüre umfassen und wobei optional die gewickelten Metallschnüre Stahl umfassen.

9. Riemen nach Anspruch 7 oder 8, wobei die Zugelemente einen Polymermatrix-Verbundwerkstoff umfassen, wobei der Polymermatrix-Verbundwerkstoff Fasern in einem Matrixmaterial beinhaltet und wobei optional die Fasern mindestens eines von Kohlenstoff, Glas, Mineral, Flüssigkristall und Aramidfasern umfassen und/oder wobei optional das Matrixmaterial mindestens eines von Polyurethan-, Epoxid-, Bismaleimid-, Phenol-, Polyimid-, Polyester- und Silikonmatrix-Verbundwerkstoffen oder Gemischen und Mischungen davon umfasst.

10. Riemen nach einem der Ansprüche 7-9, wobei 1 bis 20 Gew.-% des feuerbeständigen Materials das Siloxanpolymer sind und 1 bis 20 Gew.-% des feuerbeständigen Materials das Phosphonatpolymer sind.

11. Riemen nach einem der Ansprüche 7-10, wobei das Phosphonat-Polymer mindestens eines von einem Polyphosphonat-Homopolymer, einem Phosphonat-Oligomer, einem Phosphonat-Carbonat-Cooligomer, einem Polyphosphonat-Polycarbonat-Copolymer, einem Phosphonat-Ester-Cooligomer und einem Polyphosphonat-Polyester-Copolymer und Mischungen davon umfasst.

12. Riemen nach einem der Ansprüche 7-11, wobei das Basismaterial mindestens eines von einem thermoplastischen Elastomer, einem duroplastischen Elastomer und einem Kautschukpolymer umfasst.

13. Verfahren zum Herstellen eines feuerbeständigen Artikels, wobei der Artikel optional mindestens eines

von Folgendem ist:

einem Aufzugsriemen;
einem Handlauf für einen Personenförderer und einem Antriebsriemen;
wobei das Verfahren Folgendes umfasst:

Kombinieren eines Basismaterials mit einem Siloxanpolymer und einem Phosphonatpolymer in einer Extrusionseinrichtung; und
Extrudieren des kombinierten Basismaterials, Siloxanpolymers und Phosphonatpolymers, um einen feuerbeständigen Artikel zu bilden;
wobei das Siloxanpolymer mindestens eines von einem Polyimid-Siloxan-Copolymer, einem Polyetherimid-Siloxan-Copolymer, einem Polyetherimid-Sulfon-Siloxan-Copolymer, Polyimid-Polysiloxan-Blockcopolymeren, Polyetherimid-Polysiloxan-Blockcopolymeren, einem Polyetherimid-Sulfon-Polysiloxan-Blockcopolymer und Copolymeren und Mischungen davon umfasst.

14. Verfahren nach Anspruch 13, wobei der feuerbeständige Artikel einen Mantel für einen Riemen umfasst und optional ferner umfassend den Schritt eines Einhüllens mindestens eines Zugelements in dem Mantelmaterial.

15. Verfahren nach Anspruch 13 oder 14, umfassend Bereitstellen des Siloxanpolymermaterials für die Extrusionseinrichtung in einer fein gemahlten Form und optional umfassend Bereitstellen des Siloxanpolymermaterials für die Extrusionseinrichtung, während das Basismaterial in einer geschmolzenen Form vorliegt.

Revendications

1. Matériau résistant au feu, comprenant :

un matériau de base, un polymère de siloxane et un polymère de phosphonate, dans lequel le polymère de siloxane comprend au moins l'un parmi un copolymère de polyimide-siloxane, un copolymère de polyétherimide-siloxane, un copolymère de polyétherimide-sulfone-siloxane, des copolymères séquencés de polyimide-polysiloxane, des copolymères séquencés de polyétherimide-polysiloxane, un copolymère séquencé de polyétherimide-sulfone-polysiloxane et des copolymères et mélanges de ceux-ci.

2. Matériau résistant au feu selon la revendication 1, dans lequel 1 % à 20 % en poids du matériau résistant au feu est le polymère de siloxane et 1 % à 20 % en poids du matériau résistant au feu est le polymère de phosphonate, de préférence dans lequel 5 % à 15 % en poids du matériau résistant au feu est le polymère de siloxane et 5 % à 15 % en poids du matériau résistant au feu est le polymère de phosphonate,
3. Matériau résistant au feu selon la revendication 1 ou 2, dans lequel le polymère de phosphonate comprend au moins l'un parmi un homopolymère de polyphosphonate, un oligomère de phosphonate, un co-oligomère de carbonate-phosphonate, un copolymère de polyphosphonate-polycarbonate, un co-oligomère de phosphonate-ester et un copolymère polyphosphonate-polyester et des mélanges de ceux-ci.
4. Matériau résistant au feu selon une quelconque revendication précédente, dans lequel le matériau de base est compressible.
5. Matériau résistant au feu selon une quelconque revendication précédente, dans lequel le matériau de base comprend au moins l'un parmi un élastomère thermoplastique, un élastomère thermodurcissable et un polymère de caoutchouc, et éventuellement dans lequel le matériau de base est un polyuréthane thermoplastique.
6. Matériau résistant au feu selon une quelconque revendication précédente, dans lequel le matériau est façonné en une courroie d'entraînement d'ascenseur.
7. Courroie, comprenant :
- au moins un élément de tension ; et
- une gaine recouvrant au moins partiellement l'au moins un élément de tension, la gaine comprenant un matériau résistant au feu comprenant un matériau de base, un polymère de siloxane et un additif à base de phosphonate, dans laquelle le polymère de siloxane comprend au moins l'un parmi un copolymère de polyimide-siloxane, un copolymère de polyétherimide-siloxane, un copolymère de polyétherimide-sulfone-siloxane, des copolymères séquencés de polyimide-polysiloxane, des copolymères séquencés de polyétherimide-polysiloxane, un copolymère séquencé de polyétherimide-sulfone-polysiloxane et des copolymères et mélanges de ceux-ci.
8. Courroie selon la revendication 7, dans laquelle les éléments de tension comprennent des câbles métalliques enroulés, et éventuellement dans laquelle les câbles métalliques enroulés comprennent de l'acier.
9. Courroie selon la revendication 7 ou 8, dans laquelle les éléments de tension comprennent un composite à matrice polymère, le composite à matrice polymère comprenant des fibres dans un matériau de matrice, et éventuellement dans laquelle les fibres comprennent au moins l'un parmi des fibres de carbone, de verre, minérales, de cristaux liquides et d'aramide, et/ou éventuellement dans laquelle le matériau de matrice comprend au moins l'un parmi des composites à matrice de polyuréthane, d'époxy, de bis-maléimide, phénolique, de polyimide, de polyester et de silicone, ou des mélanges et amalgames de ceux-ci .
10. Courroie selon l'une quelconque des revendications 7 à 9, dans laquelle 1 % à 20 % en poids du matériau résistant au feu est le polymère de siloxane et 1 % à 20 % en poids du matériau résistant au feu est le polymère de phosphonate.
11. Courroie selon l'une quelconque des revendications 7 à 10, dans laquelle le polymère de phosphonate comprend au moins l'un parmi un homopolymère de polyphosphonate, un oligomère de phosphonate, un co-oligomère de carbonate-phosphonate, un copolymère de polyphosphonate-polycarbonate, un co-oligomère de phosphonate-ester et un copolymère polyphosphonate-polyester et des mélanges de ceux-ci.
12. Courroie selon l'une quelconque des revendications 7 à 11, dans laquelle le matériau de base comprend au moins l'un parmi un élastomère thermoplastique, un élastomère thermodurcissable et un polymère de caoutchouc.
13. Procédé de fabrication d'un article résistant au feu, dans lequel éventuellement l'article est au moins l'un parmi :
- une courroie d'ascenseur ;
- une main courante de convoyeur de passagers, et
- une courroie d'entraînement ;
- le procédé comprenant :
- la combinaison d'un matériau de base avec un polymère de siloxane et un polymère de phosphonate dans un équipement d'extrusion ; et
- l'extrusion du matériau de base, du polymère de siloxane et du polymère de phosphonate combinés pour former un article résistant au feu ;

dans lequel le polymère de siloxane comprend au moins l'un parmi un copolymère de polyimide-siloxane, un copolymère de polyétherimide-siloxane, un copolymère de polyétherimide-sulfone-siloxane, des copolymères séquencés de polyimide-polysiloxane, des copolymères séquencés de polyétherimide-polysiloxane, un copolymère séquencé de polyétherimide-sulfone-polysiloxane et des copolymères et mélanges de ceux-ci.

14. Procédé selon la revendication 13, dans lequel l'article résistant au feu comprend une gaine pour une courroie, et comprenant éventuellement en outre l'étape d'enfermement d'au moins un élément de tension dans le matériau de gaine.
15. Procédé selon la revendication 13 ou 14, comprenant la fourniture du matériau polymère de siloxane à l'équipement d'extrusion sous une forme finement broyée, et comprenant éventuellement la fourniture du matériau polymère de siloxane à l'équipement d'extrusion tandis que le matériau de base est sous une forme fondue.

30

35

40

45

50

55

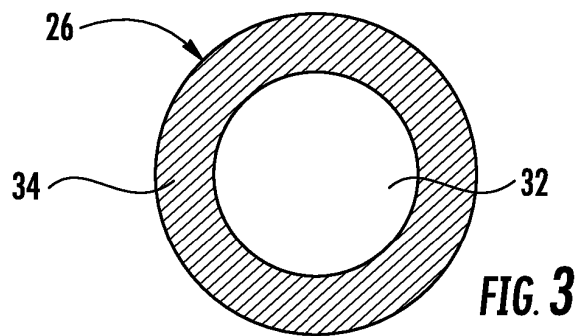
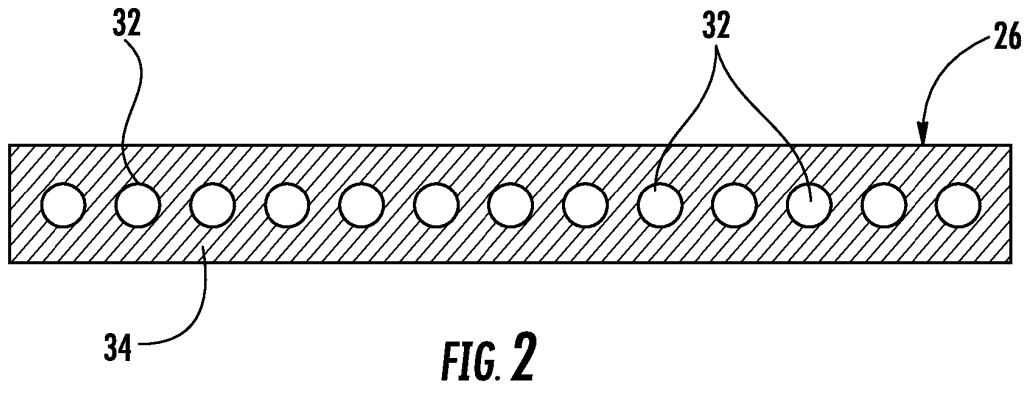
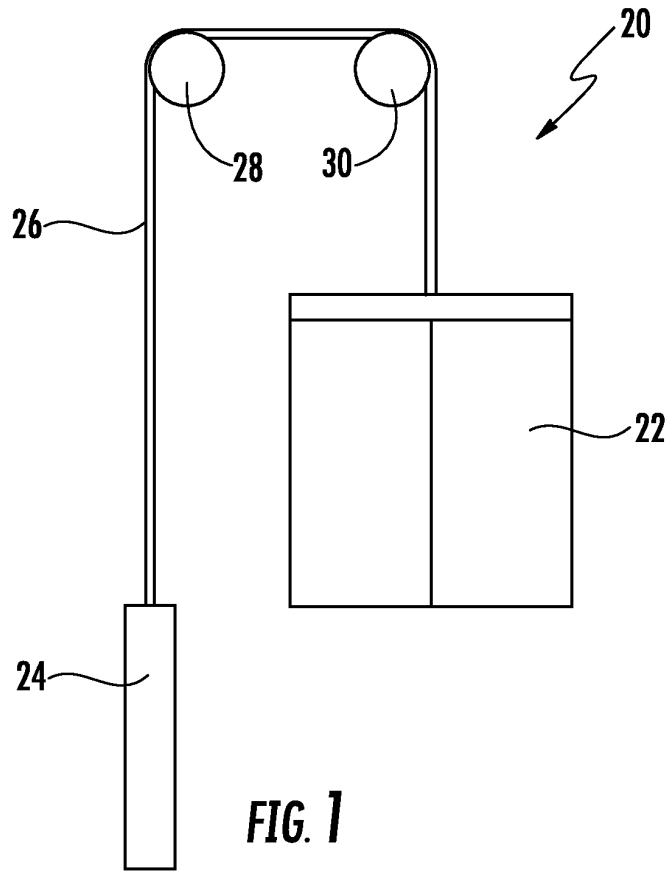

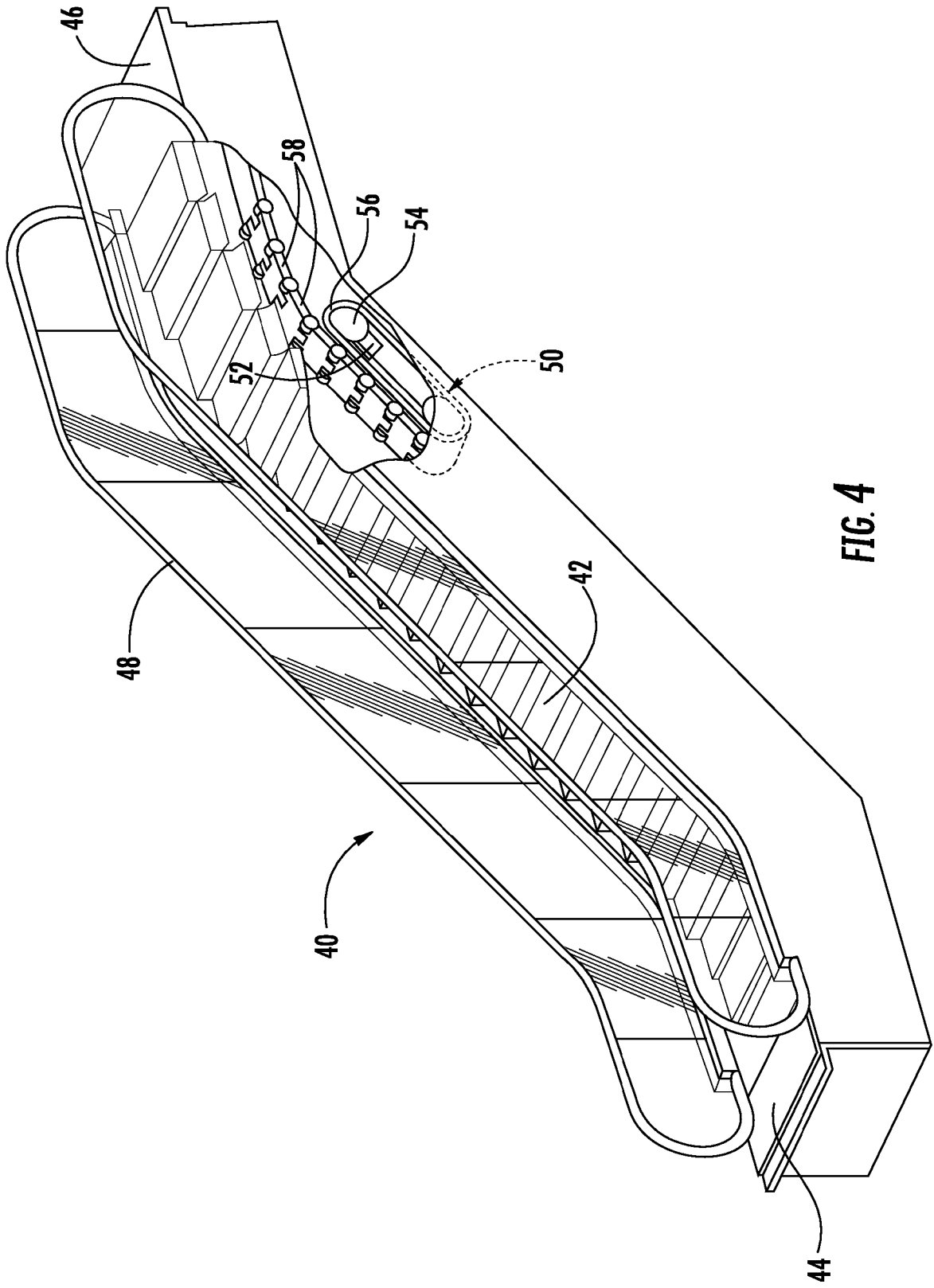

FIG. 4

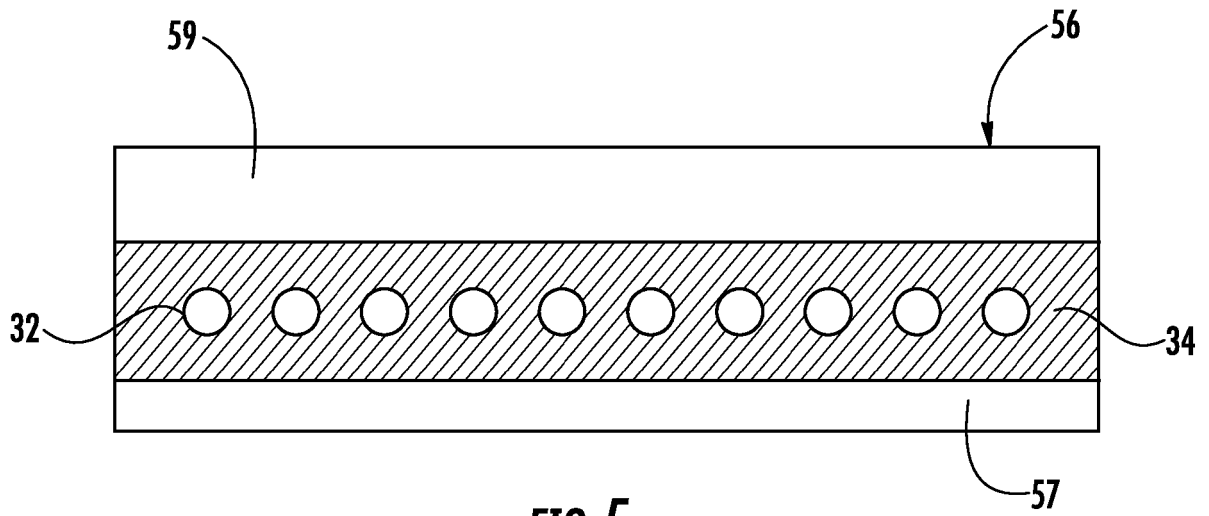

FIG. 5

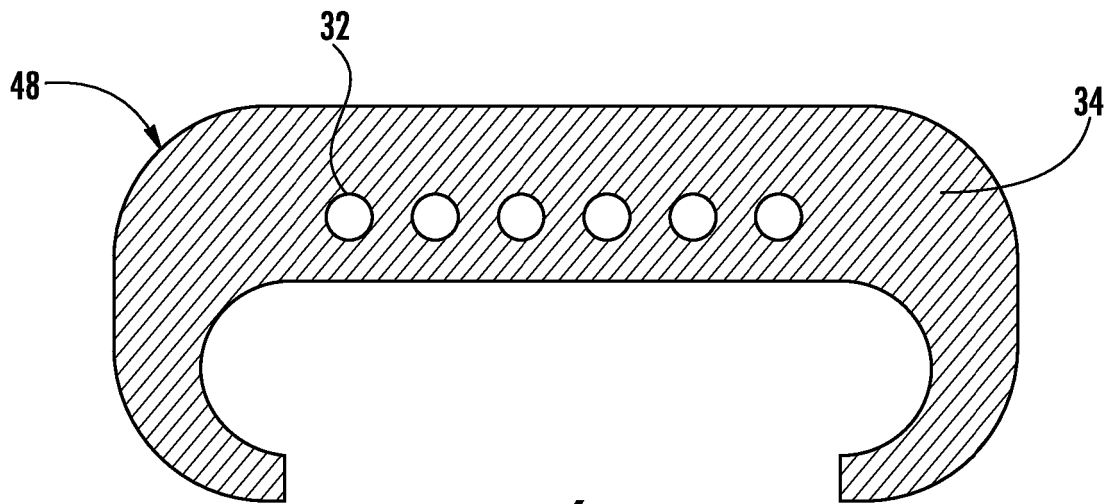

FIG. 6

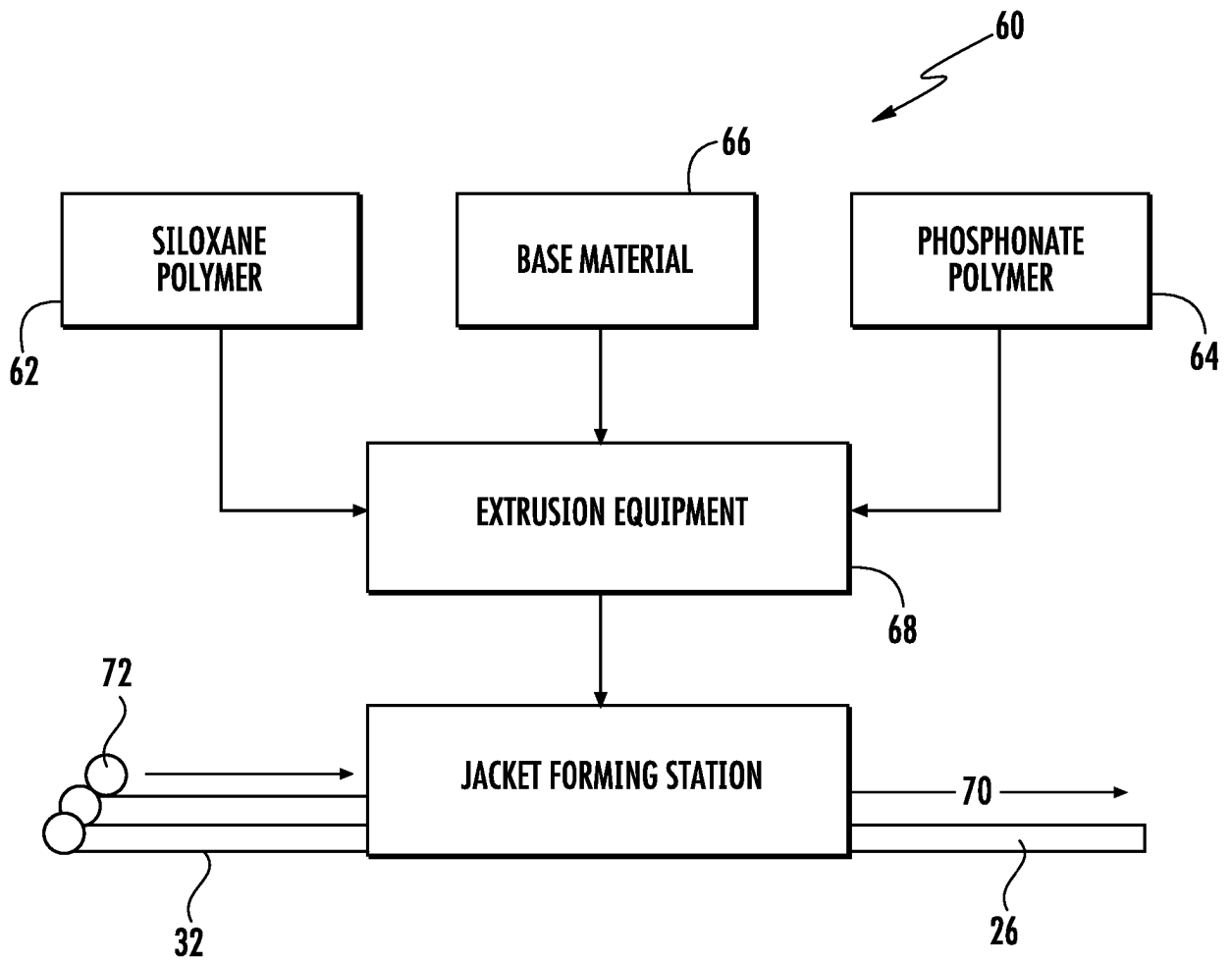

FIG. 7

REFERENCES CITED IN THE DESCRIPTION

This list of references cited by the applicant is for the reader's convenience only. It does not form part of the European patent document. Even though great care has been taken in compiling the references, errors or omissions cannot be excluded and the EPO disclaims all liability in this regard.

Patent documents cited in the description

- US 2014308505 A1 [0001]
- US 2014015168 A1 [0002]