



(11) **EP 3 409 372 B1**

(12) **EUROPEAN PATENT SPECIFICATION**

(45) Date of publication and mention of the grant of the patent:
10.11.2021 Bulletin 2021/45

(51) Int Cl.:
B03C 3/41 (2006.01) B03C 3/49 (2006.01)

(21) Application number: **17174187.9**

(22) Date of filing: **02.06.2017**

(54) **DEVICE AND METHOD FOR SEPARATING MATERIALS**

VORRICHTUNG UND VERFAHREN ZUR TRENNUNG VON MATERIALIEN

DISPOSITIF ET PROCÉDÉ DE SÉPARATION DE MATÉRIAUX

(84) Designated Contracting States:
AL AT BE BG CH CY CZ DE DK EE ES FI FR GB GR HR HU IE IS IT LI LT LU LV MC MK MT NL NO PL PT RO RS SE SI SK SM TR

(43) Date of publication of application:
05.12.2018 Bulletin 2018/49

(73) Proprietor: **Genano Oy**
02130 Espoo (FI)

(72) Inventors:
• **SAARI, Sampo**
37550 Lempäälä (FI)

- **KARJALAINEN, Panu**
36110 Ruutana (FI)
- **RÖNKKÖ, Topi**
37560 Lempäälä (FI)
- **MAKKONEN, Pasi**
01450 Vantaa (FI)

(74) Representative: **Laine IP Oy**
Porkkalankatu 24
00180 Helsinki (FI)

(56) References cited:
EP-B1- 1 165 241 JP-A- S5 756 056
US-A1- 2003 061 934

EP 3 409 372 B1

Note: Within nine months of the publication of the mention of the grant of the European patent in the European Patent Bulletin, any person may give notice to the European Patent Office of opposition to that patent, in accordance with the Implementing Regulations. Notice of opposition shall not be deemed to have been filed until the opposition fee has been paid. (Art. 99(1) European Patent Convention).

Description

FIELD

[0001] The present invention relates to a device for separating materials in the form of particles and/or drops from a gas flow. Further, the present invention relates to a method for separating materials in the form of particles and/or drops from a gas flow.

BACKGROUND

[0002] At present, filters, cyclones, or electrical methods, such as electric filters or an ion blow method, are used in gas purification systems and for separating particles from a gas flow. Methods and devices for separating particles or drops from a gas flow are e.g. known from DE 1471620 A1 and DE 19751984 A1.

[0003] Air purifiers that are currently being used have moved away from the conventional method of using filters in order to mechanically extract unwanted particles from air. Such conventional filtration systems suffer from the disadvantages that the air flow has to be limited to a slow flow stream and that the filter has to be periodically removed for cleaning. In addition, it is not possible to achieve good cleaning results with the known techniques, when the particles have a diameter in the range between a nanometer and a few dozen nanometers.

[0004] The operation of the cyclones is based on the decrease in the gas flow speed so that the heavy particles in the gas flow fall down into the collection organ. Cyclones are thus applicable for separating heavy particles.

[0005] In electric filters, the separation of particles from gas is carried out onto collection plates or to interior surfaces of pipes. The speed of the flowing gas in electric filters has to be generally under 1.0 m/second, manufacturer's recommendations being about 0.3-0.5 m/second. The reason for a small gas flow speed is that a higher flow speed releases particles accumulated onto plates, thus decreasing reduction efficiency considerably. The operation of electric filters is based on the electrostatic charge of particles. However, it is challenging to electrically charge particles in the nanometric category. In addition, all materials are not charged electrically. Low gas flow speed has to be used also because of the cleaning stage of the collection plates. When cleaning the plates, a blow is directed to the plates, releasing the collected particle material. The intention is that only the smallest possible amount of particle material released from the plates during the purification stage would get back to the flowing gas. With a small gas flow speed it is possible to achieve tolerable particle passing throughs.

[0006] Further, electric air purifiers exploit the properties of charges in ionised gas and use electrostatic means to extract the charged particles from a directed airflow. This method of extraction improves efficiency not only in terms of overall amount of particles being extracted but also the types of particles. An air purifier would typically

exploit the properties of positively or negatively charged particles where an electric field would interact with these charged particles. The charged particles would respond to the electric field and be pulled towards the ion blow onto a collection surface.

[0007] Document EP 1165241 B1, for example, discloses a method and device for separating materials in the form of particles and/or drops from a gas flow, in which method the gas flow is directed through a collection chamber the outer walls of which are grounded, and in which high tension is directed to the ion yield tips arranged in the collection chamber, thus providing an ion flow from the ion yield tips towards the collection surface, separating the desired materials from the gas flow. It is characteristic of the invention that the collection surface conducting electricity are electrically insulated from the outer casings, and that high tension with the opposite sign of direct voltage as the high tension directed to the ion yield tips is directed to the collection surface. According to an embodiment of the invention the electrical insulation is made of ABS, and the surface conducting electricity comprises a thin chrome layer arranged on the insulation layer. The ion yield tips are arranged in rings, with the help of which the distance between the ion yield tips and the collection surface is made shorter. Thus, some particles contained in the slow gas flow do not pass through the ion beams, but instead between the fastening rod and the ion yield tips.

[0008] Document US 2003/061934 A1 describes a method to clean air for separating materials in the form of particles and/or droplets from a gas flow. The gas flow is directed through a collection chamber in which the outer walls are grounded, and in which high voltage is supplied to the ion yield tips arranged in the collection chamber. Thus, an ion beam from the ion yield tips towards collection surfaces is established to separate desired material from the gas flow. The electrically conductive collection surfaces are electrically insulated from the outer castings and high voltage is supplied to the collecting surfaces, in which the direct-current voltage has an opposite sign as the high voltage directed to the ion yield tips.

[0009] In view of the foregoing, it would be beneficial to provide a method and a system further improving reduction efficiency. The system should be capable of being manufactured in industrial scale.

SUMMARY OF THE INVENTION

[0010] The invention is defined by the features of the independent claims. Some specific embodiments are defined in the dependent claims.

[0011] According to a first aspect of the present invention, there is provided a device for separating materials in the form of particles and/or drops from a gas flow, the device comprising an inlet for incoming air to be purified, a collection chamber, an outlet for the purified air, a voltage source, a fastening column to which ion yield tips

have been coupled, the device is configured to direct high tension to the ion yield tips providing ion beams from the ion yield tips to the collection surface, the collection surface conducting electricity is electrically insulated from the outer wall of the collection chamber by an electrical insulation, and the device is configured to direct voltage of opposite sign to the ion yield tips than the voltage directed to the collection surface, wherein the ion yield tips are arranged directly on a surface of the fastening column having a length, wherein the ion yield tips protrude from the surface of the fastening column into a cavity of the collection chamber, wherein a diameter of a cylindrical fastening column is in a range between 40 - 150 mm and a maximum diameter of the collection chamber is in a range between 200 - 1600 mm, or a major axis of an elliptical fastening column is in a range between 40 - 150 mm and a maximum major axis of the collection chamber is in a range between 200 - 1600 mm.

[0012] Various embodiments of the first aspect may comprise at least one feature from the following bulleted list:

- a voltage is in a range between 10 - 100 kV, preferably in a range between 10 - 60 kV
- a current is in a range between 50 - 5000 μA , preferably between 400-2300 μA , for example 1500 μA
- the length of an ion yield tip is in a range between 1-40 mm, preferably between 5-20 mm
- a volumetric flow rate of the air is in a range of 20 - 800 m^3/h , for example 200 m^3/h
- a velocity of an air flow through the cavity is in a range between 0.5 - 2.5 m/s, for example more than 1.0 m/s

[0013] According to a second aspect of the present invention, there is provided a method of separating materials in the form of particles and/or drops from a gas flow, the method comprising directing the gas flow through a collection chamber, providing a cavity for the gas flow between a fastening column and a collection surface conducting electricity that is electrically insulated from the outer wall of the collection chamber, providing ion yield tips on a surface of the fastening column, creating high tension between the ion yield tips and the collection surface providing ion yield tips on a surface of the fastening column having a length and a diameter, which ion yield tips protrude from the surface of the fastening column into the cavity of the collection chamber, directing high tension with the opposite sign of direct voltage than the high tension directed to the ion yield tips to the collection surface, separating inside the collection chamber at least a part of the materials from the gas flow, wherein a diameter of a cylindrical fastening column is in a range between 40 - 150 mm and a maximum diameter of the collection chamber is in a range between 200 - 1600 mm, or a major axis of an elliptical fastening column is in a range between 40 - 150 mm and a maximum major axis of the collection chamber is in a range between 200 -

1600 mm.

[0014] Various embodiments of the second aspect may comprise at least one feature from the following bulleted list:

- a voltage of 10 - 100 kV, preferably a voltage in a range between 10 - 60 kV, is used in the method
- a current in a range between 50-5000 μA , preferably 400-2300 μA , for example 1500 μA is used in the method
- the gas flow is guided through the cavity with a volumetric flow rate of the air is in a range of 20 - 800 m^3/h , for example 200 m^3/h
- the gas flow is guided through the cavity with a velocity in a range between 0.5 - 2.5 m/s, for example more than 1.0 m/s

[0015] Considerable advantages are obtained by certain embodiments of the invention. A system and a method of separating materials in the form of particles and/or drops from a gas flow are provided. By means of certain embodiments of the present invention separation of materials from a gas flow can be further improved. In particular, a high reduction efficiency can be achieved.

[0016] Surprisingly, increasing the diameter of the fastening column, thus also increasing the local flow speed in the cavity, does not reduce the reduction efficiency in comparison to the known systems. Surprisingly, it seems that the effect of the increased electric field and current in the cavity between the fastening column and the collection surface is more important than the effect of a higher speed of the gas flow. For example, a device according to certain embodiments of the invention using a fastening column with a diameter of 100 mm, using a voltage of 60 kV and using a current of 1400 μA has provided an excellent reduction efficiency, for example for particles having a size of greater than 50-200 nm. The reduction efficiency can be improved from about 70 % to about 80 % by means of certain embodiments of the invention. A suitable amount of ion yield tips can be arranged directly on the surface of the fastening column. The gas flow is exposed to an electric field in the cavity between the ion yield tips and the collection surface and all of the material contained in the gas flows through the cavity. There is no gas flow through rings outside the electric field. According to certain embodiments, the reduction efficiency can be also improved for particles and/or drops the diameter of which varies from one nanometer to 10 nanometers or to 20 nanometers or to a few dozen nanometers. In particular, the system according to certain embodiments of the invention also improves the reduction efficiency of particles and/or drops with a diameter of less than 10 nanometers.

BRIEF DESCRIPTION OF THE DRAWINGS

[0017]

FIGURE 1 illustrates a schematic view of a device for separating materials in accordance with at least some embodiments of the present invention, and

FIGURE 2 illustrates a schematic side view of a fastening column in accordance with at least some embodiments of the present invention.

EMBODIMENTS

[0018] The present invention relates to a device for separating materials in the form of particles and/or drops from a gas flow, the device comprising a chamber arranged within a housing providing an inlet and an outlet for an air flow. The housing provides a surface which serves as a collection surface. Inside the housing substantially at the centre is provided a column with a cylindrical or elliptical body. On the surface of the cylindrical or elliptical body a series of ion yield tips is arranged for directing ion beams to the collection surface. The column is connected to a power supply that allows the ion yield tips to generate electric fields in the form of ion beams emanating from the ion yield tips. The housing and the column are isolated from each other and they can be connected to separate power supplies so that they possess different charges for the purpose of directing the electric fields. The column is typically at least partially a cylindrical body that has a surface defined by the diameter in its cross section and the length of the body. The dimensions of the column define the cross sectional area of a cavity between the column and the collection surface. The local velocity of the air flow in the cavity can be increased by increasing the diameter of the column. Further, the larger the surface area, the more ion yield tips can be arranged on the body, thereby increasing the electric field and current generated encapsulating the body. This allows greater exposure of the electric field for the particles contained in the air flow to be charged and then directed to the collection surface for removal. The high density of the electric field created inside the chamber improves the efficiency of extraction of the particles by extracting more particles from a fast flow of air. Furthermore, all particles included in the air flow have to pass through the cavity between the column and the collection surface.

[0019] In FIGURE 1 a schematic view of a device for separating materials in accordance with at least some embodiments of the present invention is illustrated. The device 1 is designed to separate materials in the form of particles and/or drops from a gas flow. Especially, the device is designed to separate particles and/or drops the diameter of which varies from one nanometer to a few dozen nanometers. The device comprises an inlet 2 for incoming air 3 to be purified, a collection chamber 4, an outlet 6 for the purified air 7, a voltage source with actuators, and a fastening column 9 to which ion yield tips 10 have been coupled. A metal band (not shown), which surrounds the outer wall of the collection chamber, is

gounded. The fastening column 9 comprises outer surfaces forming a closed body. The device 1 is configured to guide an air flow through a cavity 14 between the fastening column 9 and a collection surface 12. The device 1 is further configured to direct high tension to the ion yield tips 10 providing ion beams 11 from the ion yield tips 10 to the collection surface 12.

[0020] The collection surface 12 conducting electricity is electrically insulated from the outer wall 5 of the collection chamber 4 by an electrical insulation. The electrical insulation may be, for example, attached to the outer wall 5 of the collection chamber 4 with the help of fasteners (not shown). The electrical insulation may be glass, plastic, acrylic-nitrile-butadiene-styrene (ABS), or some other similar substance insulating high tension, for instance.

[0021] Furthermore, the device 1 is configured to direct voltage of opposite sign to the ion yield tips 10 than the voltage directed to the collection surface 12. In other words, voltage with the opposite sign of direct voltage (positive in the figure) as the high tension directed to the ion yield tips 10 (negative in the figure) is directed to the surface 12 conducting electricity. Thus, the voltages are opposite, i.e. positive for the ion yield tips 10 and negative for the surface 12 conducting electricity, or negative for the ion producing tips 10 and positive for the surface 12 conducting electricity. Typically, the voltage of the ion yield tips 10 is substantially equal to that of the collection surface 12, but it is also possible to use voltages of different magnitude. The advantage of equal voltages is the simple structure of high tension centres. Better purification results have also been achieved with equal voltages.

[0022] The ion yield tips 10 are arranged directly on a surface 13 of the fastening column 9 having a length L_{col} and a diameter D_{col} , wherein the ion yield tips 10 protrude from the surface 13 of the fastening column into a cavity 14 of the collection chamber 4. The dimensions of the fastening column 9 define the cross sectional area of the cavity 14 between the column and the collection surface. Thus, for a given volumetric flow rate of the air application of the equation of continuity results in an increasing local velocity of the air flow through the cavity 14 with increasing diameter of the fastening column.

[0023] In FIGURE 2 a schematic side view of a fastening column 9 in accordance with at least some embodiments of the present invention is illustrated. The diameter D_{col} of the fastening column 9 is in a range between 40 - 150 mm. In particular, the diameter D_{col} of the fastening column may be e.g. 40 mm, 100 mm, or 150 mm. The ratio between the diameter D_{col} and the maximum diameter of the collection chamber may be, for example, 1:3. The fastening column 9 may e.g. include 48 ion yield tips 10. The length of an ion yield tip 10 may be in a range between 2-15 mm, for instance. In particular, the length of an ion yield tip 10 may be e.g. 5 mm or 10 mm. In FIGURE 2 the ion yield tips are arranged at an even distance relative to each other. According to certain embodiments, the ion yield tips 10 are arranged spirally wound

around the surface 13 of the fastening column 9.

[0024] Air flows through the ring-like cavity 14 of the collection chamber 4 during use of the shown fastening column 9 in a device 1 according to FIGURE 1. The volumetric flow rate of the air may be e.g. about 200 m³/h. The velocity of an air flow through the cavity 14 may be in a range between 0.5 - 2.5 m/s, for example 1.5 m/s.

[0025] All particles and/or drops contained in the air flow pass through the cavity 14 between the collection surface 12 and the surface 13 of the fastening column 13. Consequently, all particles and/or drops pass through ion beams 11, thus improving the purifying process of the air.

[0026] It is to be understood that the embodiments of the invention disclosed are not limited to the particular structures, process steps, or materials disclosed herein, but are extended to equivalents thereof as would be recognized by those ordinarily skilled in the relevant arts, as long as said equivalents fall within the scope of the appended claims which define the invention. It should also be understood that terminology employed herein is used for the purpose of describing particular embodiments only and is not intended to be limiting.

[0027] Reference throughout this specification to one embodiment or an embodiment means that a particular feature, structure, or characteristic described in connection with the embodiment is included in at least one embodiment of the present invention. Thus, appearances of the phrases "in one embodiment" or "in an embodiment" in various places throughout this specification are not necessarily all referring to the same embodiment. Where reference is made to a numerical value using a term such as, for example, about or substantially, the exact numerical value is also disclosed.

[0028] As used herein, a plurality of items, structural elements, compositional elements, and/or materials may be presented in a common list for convenience. However, these lists should be construed as though each member of the list is individually identified as a separate and unique member. Thus, no individual member of such list should be construed as a de facto equivalent of any other member of the same list solely based on their presentation in a common group without indications to the contrary. In addition, various embodiments and example of the present invention may be referred to herein along with alternatives for the various components thereof. It is understood that such embodiments, examples, and alternatives are not to be construed as de facto equivalents of one another, but are to be considered as separate and autonomous representations of the present invention, as long as said equivalents fall within the scope of the appended claims which define the invention.

[0029] Furthermore, the described features, structures, or characteristics may be combined in any suitable manner in one or more embodiments. In the following description, numerous specific details are provided, such as examples of lengths, widths, shapes, etc., to provide a thorough understanding of embodiments of the inven-

tion. One skilled in the relevant art will recognize, however, that the invention can be practiced without one or more of the specific details, or with other methods, components, materials, etc. In other instances, well-known structures, materials, or operations are not shown or described in detail to avoid obscuring aspects of the invention.

[0030] It will be apparent to those of ordinary skill in the art that numerous modifications in form, usage and details of implementation can be made without the exercise of inventive faculty. Accordingly, it is not intended that the invention be limited, except as by the claims set forth below.

[0031] The verbs "to comprise" and "to include" are used in this document as open limitations that neither exclude nor require the existence of also un-recited features. The features recited in depending claims are mutually freely combinable unless otherwise explicitly stated. Furthermore, it is to be understood that the use of "a" or "an", that is, a singular form, throughout this document does not exclude a plurality.

INDUSTRIAL APPLICABILITY

[0032] At least some embodiments of the present invention find industrial application in air purifiers and/or purifying air. Very suitable uses being particularly isolation rooms in hospitals, operating rooms, factories manufacturing microchips, and air intake in such rooms in which biological weapons have to be repelled. Of course, the present invention may also find application in purification of rooms in homes and offices.

Claims

1. A device (1) for separating materials in the form of particles and/or drops from a gas flow, the device (1) comprising:
 - an inlet (2) for incoming air (3) to be purified,
 - a collection chamber (4),
 - an outlet (6) for the purified air (7),
 - a voltage source (8),
 - a fastening column (9) to which ion yield tips (10) have been coupled, wherein the ion yield tips (10) are arranged directly on a surface (13) of the fastening column (9) having a length (L_{col}), and wherein the ion yield tips (10) protrude from the surface (13) of the fastening column (9) into a cavity (14) of the collection chamber (4),
 - the device (1) is configured to direct high tension to the ion yield tips (10) providing ion beams (11) from the ion yield tips (10) to a collection surface (12),
 - the collection surface (12) conducting electricity is electrically insulated from an outer wall (5) of the collection chamber (4) by an electrical in-

sulation, and

- the device (1) is configured to direct voltage of opposite sign to the ion yield tips (10) than the voltage directed to the collection surface (12),

characterised in that

a diameter (D_{col}) of a cylindrical fastening column (9) is in a range between 40 - 150 mm and a maximum diameter ($D_{chamber}$) of the collection chamber (4) is in a range between 200 - 1600 mm, or

a major axis of an elliptical fastening column (9) is in a range between 40 - 150 mm and a maximum major axis of the collection chamber (4) is in a range between 200 - 1600 mm.

2. The device (1) according to claim 1, wherein a voltage is in a range between 10 - 100 kV, preferably in a range between 10 - 60 kV.

3. The device (1) according to claim 1 or 2, wherein a current is in a range between 50 - 5000 μ A, preferably between 400-2300 μ A, for example 1500 μ A.

4. The device (1) according to any one of claims 1-3, wherein the length of an ion yield tip is in a range between 1-40 mm, preferably between 5-20 mm.

5. The device (1) according to any one of claims 1-4, wherein a volumetric flow rate of the air is in a range of 20 - 800 m³/h, for example 200 m³/h.

6. The device (1) according to any one of claims 1-5, wherein a velocity of an air flow through the cavity (14) is in a range between 0.5 - 2.5 m/s, for example more than 1.0 m/s.

7. A method of separating materials in the form of particles and/or drops from a gas flow, the method comprising:

- directing the gas flow through a collection chamber (4),

- providing a cavity (14) for the gas flow between a fastening column (9) and a collection surface (12) conducting electricity that is electrically insulated from the outer wall (5) of the collection chamber (4),

- providing ion yield tips (10) on a surface (13) of the fastening column (9) having a length (L_{col}), which ion yield tips (10) protrude from the surface (13) of the fastening column (9) into the cavity (14) of the collection chamber (4), wherein a diameter (D_{col}) of a cylindrical fastening column (9) is in a range between 40 - 150 mm and a maximum diameter ($D_{chamber}$) of the collection chamber (4) is in a range between 200 - 1600

mm, or a major axis of an elliptical fastening column (9) is in a range between 40 - 150 mm and a maximum major axis of the collection chamber (4) is in a range between 200 - 1600 mm,

- creating high tension between the ion yield tips (3) and the collection surface (12),

- directing high tension with the opposite sign of direct voltage than the high tension directed to the ion yield tips (10) to the collection surface (12),

- separating inside the collection chamber (4) at least a part of the materials from the gas flow.

8. The method according to claim 7, wherein a voltage of 10 - 100 kV, preferably a voltage in a range between 10 - 60 kV, is used in the method.

9. The method according to claim 7 or 8, wherein a current in a range between 50-5000 μ A, preferably 400-2300 μ A, for example 1500 μ A is used in the method.

10. The method according to any one of claims 7-9, wherein the gas flow is guided through the cavity with a volumetric flow rate of the air in a range of 20 - 800 m³/h, for example 200 m³/h.

11. The method according to any one of claims 7-10, wherein the gas flow is guided through the cavity with a velocity in a range between 0.5 - 2.5 m/s, for example more than 1.0 m/s.

Patentansprüche

1. Vorrichtung (1) zum Abscheiden von Materialien in der Form von Partikeln und/oder Tropfen aus einem Gasfluss, wobei die Vorrichtung (1) Folgendes umfasst:

- einen Einlass (2) für Zuluft (3), die gereinigt werden soll,

- eine Sammelkammer (4),

- einen Auslass (6) für die gereinigte Luft (7),

- eine Spannungsquelle (8),

- eine Befestigungssäule (9), an die Ionenausbeutespitzen (10) gekoppelt sind, wobei die Ionenausbeutespitzen (10) direkt auf einer Oberfläche (13) der Befestigungssäule (9) angeordnet sind, die eine Länge ($L_{säule}$) aufweist, und wobei die Ionenausbeutespitzen (10) von der Oberfläche (13) der Befestigungssäule (9) in einen Hohlraum (14) der Sammelkammer (4) vorstehen,

- wobei die Vorrichtung (1) konfiguriert ist, um eine Hochspannung zu den Ionenausbeutespitzen (10) zu leiten, wobei Ionenstrahlen (11) von den Ionenausbeutespitzen (10) zu einer

Sammeloberfläche (12) bereitgestellt werden,
 - wobei die Sammeloberfläche (12), die elektrisch leitet, von einer Außenwand (5) der Sammelkammer (4) durch eine elektrische Isolierung elektrisch isoliert ist, und
 - wobei die Vorrichtung (1) konfiguriert ist, um eine Spannung mit entgegengesetztem Vorzeichen zu den Ionenausbeutespitzen (10) zu leiten als die Spannung, die zu der Sammeloberfläche (12) geleitet ist,

dadurch gekennzeichnet, dass

- ein Durchmesser ($D_{\text{Säule}}$) einer zylindrischen Befestigungssäule (9) in einem Bereich zwischen 40-150 mm liegt und ein maximaler Durchmesser (D_{Kammer}) der Sammelkammer (4) in einem Bereich zwischen 200-1600 mm liegt, oder
 eine Hauptachse einer elliptischen Befestigungssäule (9) in einem Bereich zwischen 40-150 mm liegt und eine maximale Hauptachse der Sammelkammer (4) in einem Bereich zwischen 200-1600 mm liegt.
2. Vorrichtung (1) nach Anspruch 1, wobei eine Spannung in einem Bereich zwischen 10-100 kV, vorzugsweise in einem Bereich zwischen 10-60 kV, liegt.
 3. Vorrichtung (1) nach Anspruch 1 oder 2, wobei eine Strömung in einem Bereich zwischen 50-5000 μA , vorzugsweise zwischen 400-2300 μA , beispielsweise 1500 μA , liegt.
 4. Vorrichtung (1) nach einem der Ansprüche 1-3, wobei die Länge einer Ionenausbeutespitze in einem Bereich zwischen 1-40 mm, vorzugsweise zwischen 5-20 mm, liegt.
 5. Vorrichtung (1) nach einem der Ansprüche 1-4, wobei eine Volumenflussrate der Luft in einem Bereich von 20-800 m^3/h , beispielsweise 200 m^3/h , liegt.
 6. Vorrichtung (1) nach einem der Ansprüche 1-5, wobei eine Geschwindigkeit eines Luftflusses durch den Hohlraum (14) in einem Bereich zwischen 0,5-2,5 m/s, beispielsweise über 1,0 m/s, liegt.
 7. Verfahren zum Abscheiden von Materialien in der Form von Partikeln und/oder Tropfen aus einem Gasfluss, wobei das Verfahren Folgendes umfasst:
 - Leiten des Gasflusses durch eine Sammelkammer (4),
 - Bereitstellen eines Hohlraums (14) für den Gasfluss zwischen einer Befestigungssäule (9) und einer Sammeloberfläche (12), die elektrisch

leitet, die von der Außenwand (5) der Sammelkammer (4) elektrisch isoliert ist,
 - Bereitstellen von Ionenausbeutespitzen (10) auf einer Oberfläche (13) der Befestigungssäule (9), die eine Länge ($L_{\text{Säule}}$) aufweist, aus der Ionenausbeutespitzen (10) von der Oberfläche (13) der Befestigungssäule (9) in den Hohlraum (14) der Sammelkammer (4) vorstehen, wobei ein Durchmesser ($D_{\text{Säule}}$) einer zylindrischen Befestigungssäule (9) in einem Bereich zwischen 40-150 mm liegt und ein maximaler Durchmesser (D_{Kammer}) der Sammelkammer (4) in einem Bereich zwischen 200-1600 mm liegt, oder eine Hauptachse einer elliptischen Befestigungssäule (9) in einem Bereich zwischen 40-150 mm liegt und eine maximale Hauptachse der Sammelkammer (4) in einem Bereich zwischen 200-1600 mm liegt,
 - Erzeugen von Hochspannung zwischen den Ionenausbeutespitzen (3) und der Sammeloberfläche (12),
 - Leiten von Hochspannung mit dem entgegengesetzten Vorzeichen von Gleichspannung zu der Sammeloberfläche (12), als die Hochspannung, die zu den Ionenausbeutespitzen (10) geleitet ist,
 - Abscheiden innerhalb der Sammelkammer (4) wenigstens eines Teils der Materialien aus dem Gasfluss.

8. Verfahren nach Anspruch 7, wobei bei dem Verfahren eine Spannung von 10-100 kV, vorzugsweise eine Spannung in einem Bereich zwischen 10-60 kV, verwendet wird.
9. Verfahren nach Anspruch 7 oder 8, wobei bei dem Verfahren eine Strömung in einem Bereich zwischen 50-5000 μA , vorzugsweise 400-2300 μA , beispielsweise 1500 μA , verwendet wird.
10. Verfahren nach einem der Ansprüche 7-9, wobei der Gasfluss mit einer Volumenflussrate der Luft in einem Bereich von 20-800 m^3/h , beispielsweise 200 m^3/h , durch den Hohlraum geführt wird.
11. Verfahren nach einem der Ansprüche 7-10, wobei der Gasfluss mit einer Geschwindigkeit in einem Bereich zwischen 0,5-2,5 m/s, beispielsweise über 1,0 m/s, durch den Hohlraum geführt wird.

Revendications

1. Dispositif (1) de séparation de matériaux sous forme de particules et/ou de gouttes d'un écoulement gazeux, le dispositif (1) comprenant :
 - une entrée (2) pour l'air entrant (3) à épurer,

- une chambre de collecte (4),
- une sortie (6) pour l'air épuré (7),
- une source de tension (8),
- une colonne de fixation (9) à laquelle ont été accouplées des pointes de production d'ions (10), les pointes de production d'ions (10) étant disposées directement sur une surface (13) de la colonne de fixation (9) ayant une longueur (L_{col}), et les pointes de production d'ions (10) faisant saillie de la surface (13) de la colonne de fixation (9) dans une cavité (14) de la chambre de collecte (4),
- le dispositif (1) étant configuré pour diriger une haute tension vers les pointes de production d'ions (10) fournissant des faisceaux d'ions (11) depuis les pointes de production d'ions (10) vers une surface de collecte (12),
- la surface de collecte (12) conductrice d'électricité étant isolée électriquement d'une paroi externe (5) de la chambre de collecte (4) par une isolation électrique, et
- le dispositif (1) étant configuré pour diriger une tension de signe opposé vers les pointes de production d'ions (10) que la tension dirigée vers la surface de collecte (12),

caractérisé en ce que

- un diamètre (D_{col}) d'une colonne de fixation (9) cylindrique est dans une plage de 40 à 150 mm et un diamètre maximal ($D_{chambre}$) de la chambre de collecte (4) est dans une plage de 200 à 1 600 mm, ou
- un grand axe d'une colonne de fixation elliptique (9) est dans une plage de 40 à 150 mm et un grand axe maximal de la chambre de collecte (4) est dans une plage de 200 à 1 600 mm.
2. Dispositif (1) selon la revendication 1, dans lequel une tension est dans une plage de 10 à 100 kV, de préférence dans une plage de 10 à 60 kV.
 3. Dispositif (1) selon la revendication 1 ou 2, dans lequel un courant est dans une plage de 50 à 5 000 μA , de préférence de 400 à 2 300 μA , par exemple 1 500 μA .
 4. Dispositif (1) selon l'une quelconque des revendications 1 à 3, dans lequel la longueur d'une pointe de production d'ions est une plage de 1 à 40 mm, de préférence de 5 à 20 mm.
 5. Dispositif (1) selon l'une quelconque des revendications 1 à 4, dans lequel un débit d'écoulement volumétrique de l'air est dans une plage de 20 à 800 m^3/h , par exemple 200 m^3/h .
 6. Dispositif (1) selon l'une quelconque des revendica-

tions 1 à 5, dans lequel une vitesse d'un écoulement d'air à travers la cavité (14) est dans une plage de 0,5 à 2,5 m/s, par exemple supérieure à 1,0 m/s.

7. Procédé de séparation de matériaux sous forme de particules et/ou de gouttes d'un écoulement gazeux, le procédé comprenant :
 - le fait de diriger l'écoulement gazeux à travers une chambre de collecte (4),
 - la fourniture d'une cavité (14) pour l'écoulement gazeux entre une colonne de fixation (9) et une surface de collecte (12) conductrice d'électricité qui est isolée électriquement de la paroi externe (5) de la chambre de collecte (4),
 - la fourniture de pointes de production d'ions (10) sur une surface (13) de la colonne de fixation (9) ayant une longueur (L_{col}), lesquelles pointes de production d'ions (10) font saillie de la surface (13) de la colonne de fixation (9) dans la cavité (14) de la chambre de collecte (4), un diamètre (D_{col}) d'une colonne de fixation (9) cylindrique étant dans une plage de 40 à 150 mm et un diamètre maximal ($D_{chambre}$) de la chambre de collecte (4) étant dans une plage de 200 à 1 600 mm, ou un grand axe d'une colonne de fixation (9) elliptique étant dans une plage de 40 à 150 mm et un grand axe maximal de la chambre de collecte (4) étant dans une plage de 200 à 1 600 mm,
 - la création d'une haute tension entre les pointes de production d'ions (3) et la surface de collecte (12),
 - le fait de diriger une haute tension avec le signe opposé de tension continue que la haute tension dirigée vers les pointes de production d'ions (10) vers la surface de collecte (12),
 - la séparation à l'intérieur de la chambre de collecte (4) d'au moins une partie des matériaux de l'écoulement gazeux.
8. Procédé selon la revendication 7, dans lequel une tension de 10 à 100 kV, de préférence une tension dans une plage de 10 à 60 kV, est utilisée dans le procédé.
9. Procédé selon la revendication 7 ou 8, dans lequel un courant dans une plage de 50 à 5 000 μA , de préférence 400 à 2 300 μA , par exemple 1 500 μA est utilisé dans le procédé.
10. Procédé selon l'une quelconque des revendications 7 à 9, dans lequel l'écoulement gazeux est guidé à travers la cavité avec un débit d'écoulement volumétrique de l'air dans une plage de 20 à 800 m^3/h , par exemple 200 m^3/h .
11. Procédé selon l'une quelconque des revendications

7 à 10, dans lequel l'écoulement gazeux est guidé à travers la cavité avec une vitesse dans une plage de 0,5 à 2,5 m/s, par exemple supérieure à 1,0 m/s.

5

10

15

20

25

30

35

40

45

50

55

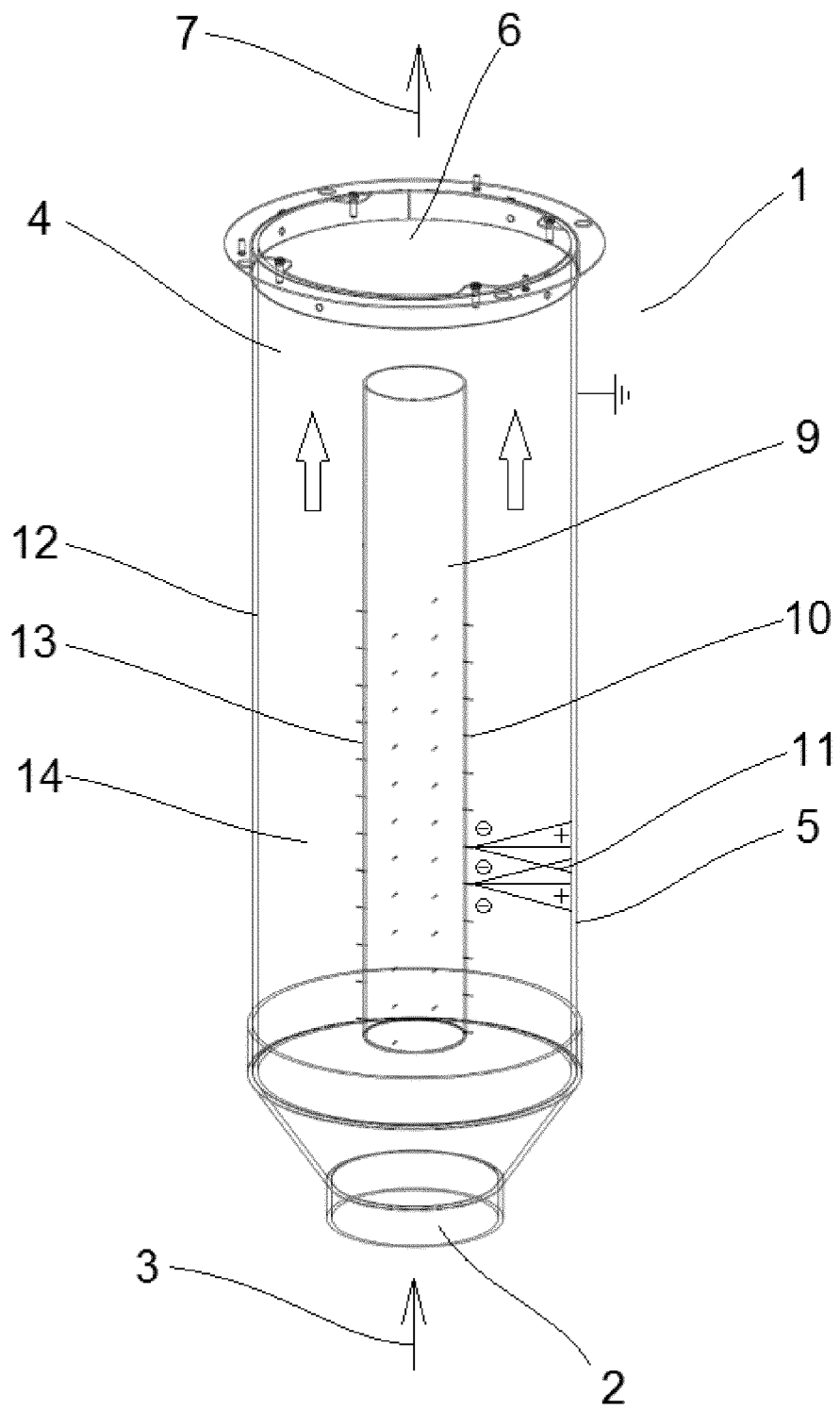

FIG. 1

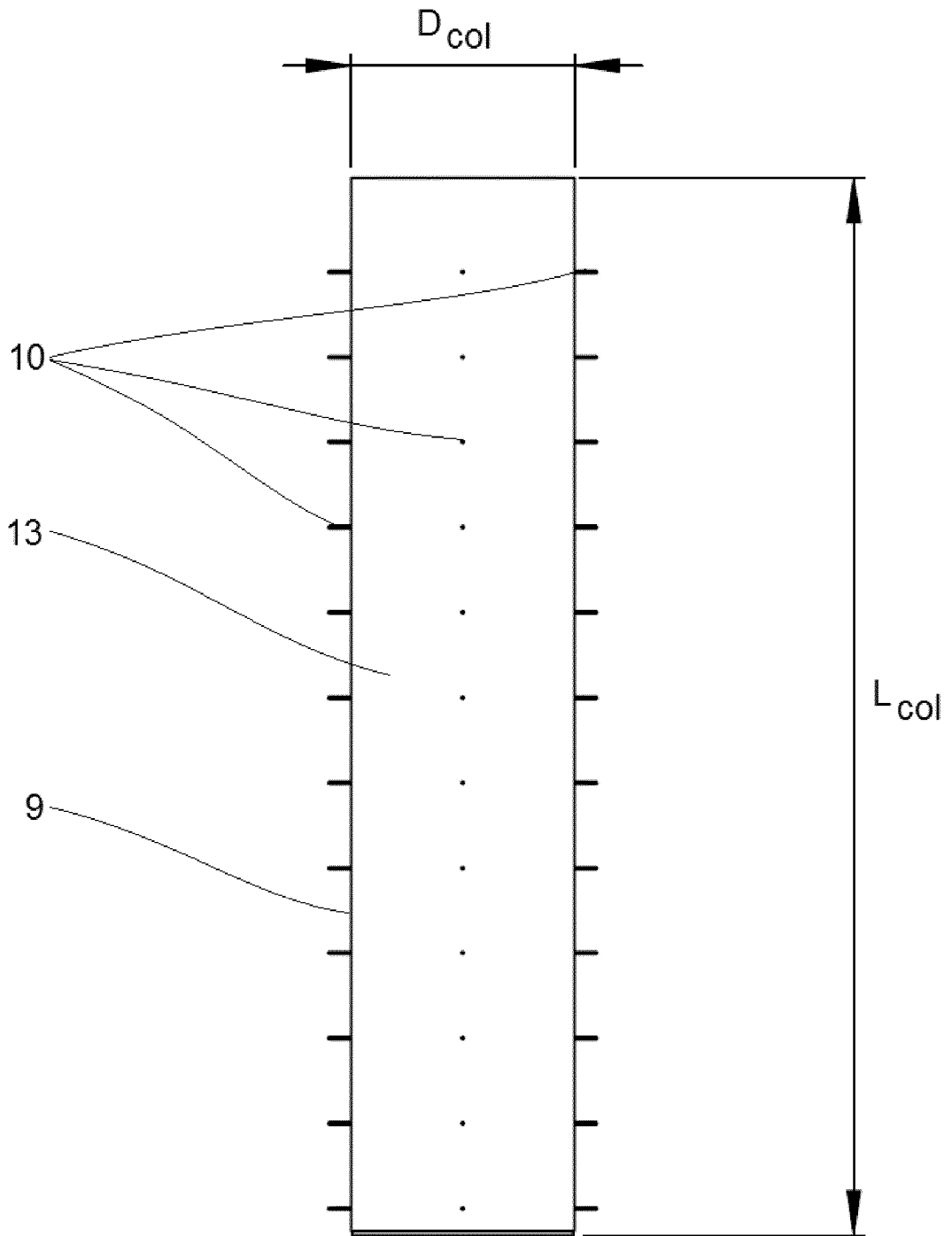

FIG. 2

REFERENCES CITED IN THE DESCRIPTION

This list of references cited by the applicant is for the reader's convenience only. It does not form part of the European patent document. Even though great care has been taken in compiling the references, errors or omissions cannot be excluded and the EPO disclaims all liability in this regard.

Patent documents cited in the description

- DE 1471620 A1 [0002]
- DE 19751984 A1 [0002]
- EP 1165241 B1 [0007]
- US 2003061934 A1 [0008]