



(11) **EP 3 417 172 B1**

(12) **EUROPEAN PATENT SPECIFICATION**

(45) Date of publication and mention of the grant of the patent:
13.10.2021 Bulletin 2021/41

(51) Int Cl.:
F04B 17/04 ^(2006.01) **F04B 53/02** ^(2006.01)
F04B 53/10 ^(2006.01) **F04B 53/14** ^(2006.01)

(21) Application number: **17714003.5**

(86) International application number:
PCT/IB2017/000111

(22) Date of filing: **13.02.2017**

(87) International publication number:
WO 2017/141099 (24.08.2017 Gazette 2017/34)

(54) **SOLENOID PUMP**

SOLENOID-PUMPE

POMPE À SOLÉNOÏDE

(84) Designated Contracting States:
AL AT BE BG CH CY CZ DE DK EE ES FI FR GB GR HR HU IE IS IT LI LT LU LV MC MK MT NL NO PL PT RO RS SE SI SK SM TR

(74) Representative: **Riccardi, Sergio**
Riccardi & Co.
Via Macedonio Melloni, 32
20129 Milano (IT)

(30) Priority: **15.02.2016 IT UB20165515 U**

(56) References cited:
EP-A1- 0 185 044 EP-A2- 1 818 538
WO-A1-2015/017523 CN-U- 203 286 129
DE-A1- 4 213 798 DE-A1- 19 920 996
FR-A- 619 837 US-A- 4 655 945
US-A- 4 915 591 US-A- 5 695 197

(43) Date of publication of application:
26.12.2018 Bulletin 2018/52

(73) Proprietor: **Ode S.r.l.**
23823 Colico (LC) (IT)

(72) Inventor: **BOSISIO, Andrea**
22015 Gravellona ed Uniti (CO) (IT)

EP 3 417 172 B1

Note: Within nine months of the publication of the mention of the grant of the European patent in the European Patent Bulletin, any person may give notice to the European Patent Office of opposition to that patent, in accordance with the Implementing Regulations. Notice of opposition shall not be deemed to have been filed until the opposition fee has been paid. (Art. 99(1) European Patent Convention).

Description

[0001] The present invention relates to a solenoid pump for apparatus for delivering and dispensing beverages as claimed in claim 1.

[0002] Vibration pumps, more particularly those used in apparatus for delivering and dispensing beverages, such as automatic coffee percolators and dispensers for hot and/or cold beverages, more particularly when installed in industrial or commercial companies or public buildings, are operated every day a lot of times, so that all their components should be strong and durable.

[0003] More particularly the stressing alternative motion (50/60 Hz) of the plunger wears readily the seals which are vital for the correct pump operation. For this reason the average life of these seals is warranted by the pump manufacturers for about 18,000 operating cycles, approximately corresponding to one year of operation, that is equal to the expected time interval between two scheduled maintenance actions.

[0004] In view of the steadily increasing maintenance costs and the inconveniences due to the apparatus stops, with troubles for the users and loss of takings for the managers of the apparatus, the problem of manufacturing long-life vibration pumps is particularly critical, thus requiring first of all to have available reliable and durable seals allowing to extend considerably the intervals between two maintenance actions. A pump according to the prior art is disclosed in document EP1818538.

[0005] A different type of pump (metering precision pump) is disclosed in the document US 4 915 591 wherein specific materials are used in order to achieve transparency and visual accessibility and control of the pump or check valve movement.

[0006] In the document EP 0 185 044 a particular composition for sealing materials is disclosed wherein filler particles with a specific Rockwell C hardness are used to reinforce a PTFE polymer matrix.

[0007] In the document US 4 655 945 a method for the manufacture bearing seals with a wide range of fillers dimension is disclosed.

[0008] In the document DE 42 13 798 a radial piston fuel pump comprising ceramic components (specifically silicon nitride check valve) is disclosed.

[0009] In the document DE 199 20 996 a radial piston pump comprising ceramic component (a check valve in a no better specified ceramic material) is disclosed.

[0010] Therefore Applicant studied carefully and brilliantly solved this problem by creating proper compositions of matter for these seals, which when subjected to accelerated artificial ageing showed to be adapted to increase five times the normal life of pumps, extending the average life of their seals from said 18,000 cycles to 90,000 cycles, approximately corresponding to five operative years, thus creating a new generation of long-life vibration pumps, requiring only a maintenance action every five years.

[0011] These seals are those applied to the pump

plunger, warranting fluidic tightness in a passage having a diameter of about 5 mm, so that their material, in spite of the tiny dimensions and thickness, must have an exceptional durability and strength.

[0012] These seals comprise a C-ring used as a plunger sealing pad made of fiberglass filled PTFE (polytetrafluoroethylene), and a ball used as a check valve after the plunger, said ball consisting of aluminum oxide or similar ceramic metals.

[0013] The PTFE composite used for the C-ring pad is a material specially designed for this use, made by extrusion of pure PTFE with glass fibers of a length in the range of 30 to 80 microns. The fiberglass filler may be varied from 5% to 25% by weight; consequently the composite may comprise 95% - 75% PTFE and 5% - 25% fiberglass, the preferred formulation used is the mean composition of 85% PTFE and 15% fiberglass.

[0014] As a mere illustrative non limiting example, in the accompanying sheet of drawings, Figure 1 shows a conventional type of vibration pump, showing the position of the sealing C-ring 10 on the plunger P and the ball 20 as check valve.

[0015] Figure 2 is a highly enlarged cross-sectional view of the C-ring 10, showing two round lips 12 defining the outer race 14 in which a conventional gasket is arranged.

[0016] Clearly the exact dimensions and positions of the seals may be varied according to the type of vibration pump, and the materials used to make the seals will always be certified as suitable for use in foodstuff contact compatible components according to the laws, regulations and norms in force.

Claims

1. A solenoid pump for apparatus for delivering and dispensing beverages, such as automatic coffee percolators and dispensers for hot and/or cold beverages, said solenoid pump including:

- a plunger, having an alternative motion and
- a kit of seals, comprising:

- a sealing pad (10) between said pump sleeve and said pump plunger (P),
- a check valve (20) after the plunger (P), and
- a conventional gasket,

said solenoid pump being **characterized in that:**

- the sealing pad (10) consists of a C-ring provided with two round lips (12) defining an outer race (14),
- the material of the C-ring consists of PTFE extruded with glass fibers of a length in the range

of 30 to 80 microns, comprises 95% to 75% by weight of PTFE and 5% to 25% by weight of fiberglass,

- said conventional gasket is arranged within said outer race (14), and
- the check valve (20) comprises a ball of aluminium oxide.

2. The solenoid pump according to claim 2, wherein the material of the C-ring consists of 85% PTFE and 15% glass fibers.

Patentansprüche

1. Solenoidpumpe für Anlagen für die Abgabe und Versorgung von Getränken, wie Kaffeemaschinen und Automaten für andere kalte und/oder warme Getränke, worin die Solenoidpumpe folgendes enthält:

- einen Kolben mit Hin- und Herbewegung, und
- einen Bausatz von Dichtungen, enthaltend:
- eine Dichtscheibe (10) zwischen dem Pumpenstutzen und dem Pumpenkolben (P),
- ein Rückschlagventil (20) nach dem Kolben (P); und
- eine herkömmliche Dichtung,

worin die besagte Solenoidpumpe **dadurch gekennzeichnet** wird, dass

- die Dichtschiebe (10) einen C-Ring aufweist, der zwei eine äussere Rille (14) bestimmenden Rundlippen (12) hat;
- der Werkstoff des C-Rings ist mit Glasfaserstoff extrudiertes Polytetrafluoräthylen (PTFE), worin die Glasfaser eine Länge im Bereich 30 bis 80 microns haben, und Werkstoff 95 bis 75 Gewichtsprozent PTFE und 5 bis 25 Gewichtsprozent Glasfaser aufweist;
- die besagte herkömmliche Dichtung wird innerhalb der äusseren Rille (14) angeordnet, und
- das Rückschlagventil (20) eine Kugel von Aluminiumoxid aufweist.

2. Solenoidpumpe nach Anspruch 1, worin der Werkstoff des C-Rings 85% PTFE und 15% Glasfaser enthält.

Revendications

1. Pompe à solénoïde pour appareils de distribution et fourniture des boissons, tels que machines automatiques pour café et distributeurs pour boissons chaudes et/ou froides, ladite pompe à solénoïde comprenant :

- un piston avec un mouvement alterné, et
 - un kit d'étanchéité, comprenant :
 - un tampon de garniture (10) entre un manchon de pompe et le piston (P) de pompe,
 - un clapet de non-retour (20) après le piston (P), et
 - une garniture étanche conventionnelle ;
- Ladite pompe à solénoïde étant **caractérisée en ce que** :

- Le tampon de garniture (10) est un anneau (C-ring) ayant deux lèvres circulaires (12) en définissant une gorge extérieure (14) ;
- Le matériau de l'anneau (C-ring) est formé par polytétrafluoréthylène (PTFE) extrudé par fibres de verre avec une longueur de 30 à 80 microns, comprenant de 95% à 75% en poids de PTFE et de 5% à 25% en poids de fibres de verre ;
- La garniture conventionnelle est disposée dans ladite gorge extérieure (14) ; et
- Le clapet de non-retour (20) comprend une bille d'oxyde d'aluminium.

2. Pompe à solénoïde selon la revendication 1, dont le matériau de l'anneau (C-ring) est formé par 85% de PTFE et 15% fibres de verre.

Fig. 1

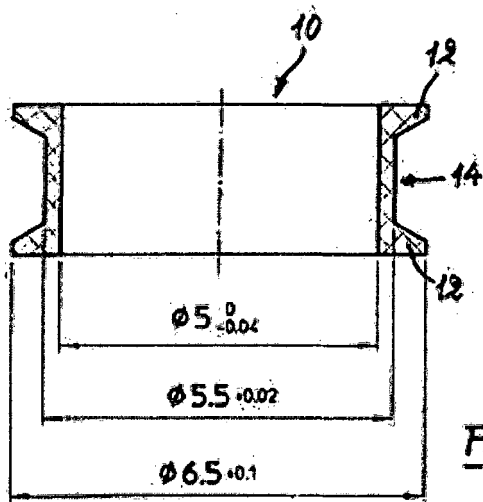
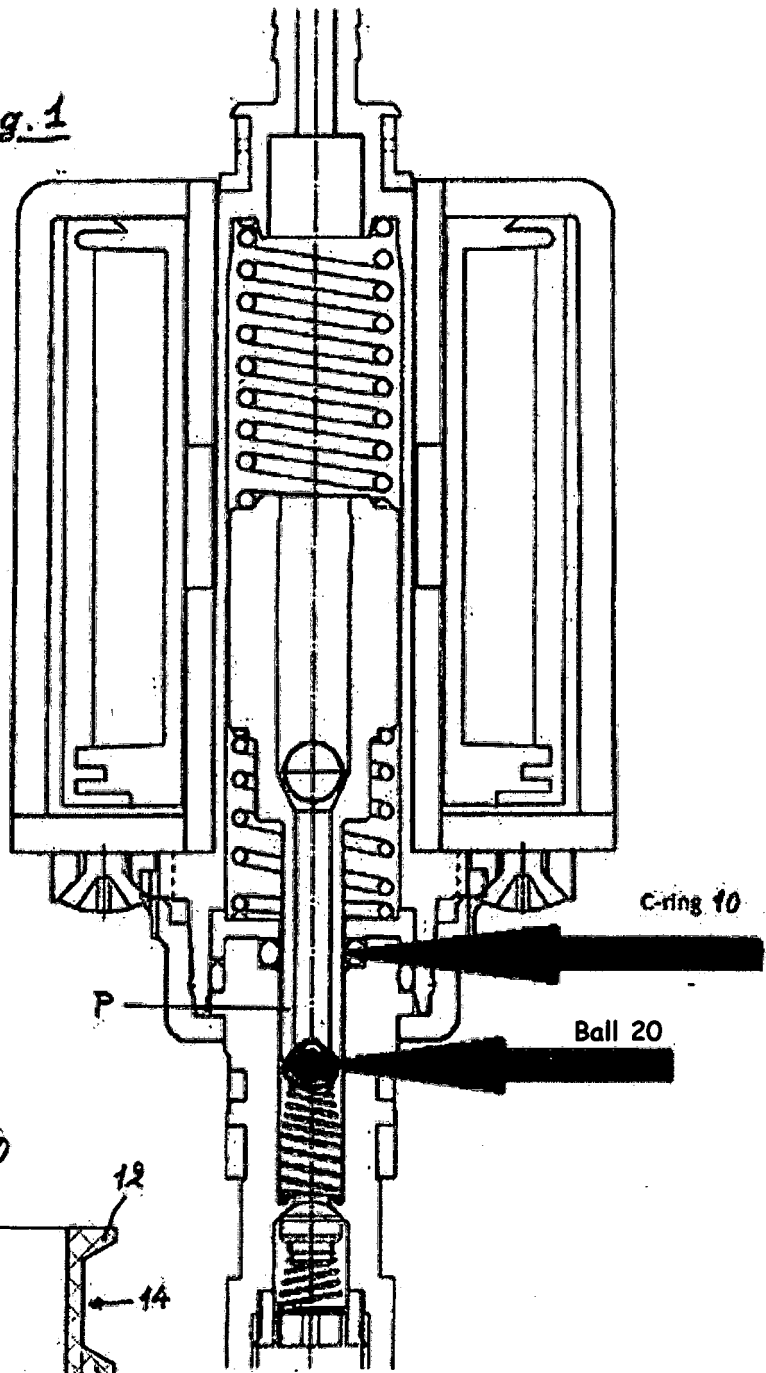

Fig. 2

REFERENCES CITED IN THE DESCRIPTION

This list of references cited by the applicant is for the reader's convenience only. It does not form part of the European patent document. Even though great care has been taken in compiling the references, errors or omissions cannot be excluded and the EPO disclaims all liability in this regard.

Patent documents cited in the description

- EP 1818538 A **[0004]**
- US 4915591 A **[0005]**
- EP 0185044 A **[0006]**
- US 4655945 A **[0007]**
- DE 4213798 A **[0008]**
- DE 19920996 A **[0009]**