

Description**TECHNICAL FIELD**

[0001] The present disclosure relates to the technical field of packaging, for example, to a packaging box, a packaging box unfolded plate and an assembly method.

BACKGROUND

[0002] A packaging box in the related art is designed with cross-inserting at a bottom of the box. In this way, the packaging box may be easily broken at the bottom under the gravity of articles in the box, thereby affecting the packaging of the articles.

SUMMARY

[0003] The present disclosure provides a packaging box, a packaging box unfolded plate and an assembling method, which can prevent a bottom of the packaging box from loosening and breaking.

[0004] A packaging box includes a first unfolded plane for forming a quadrangular cylinder; and a second unfolded plane being vertical to the first unfolded plane and extending from an edge of the first unfolded plane; and the second unfolded plane includes a bottom plate, a rear wall and a top cover, which extend outwards in sequence.

[0005] Optionally, a base is disposed on an upper surface of the bottom plate of the second unfolded plane and a positioning piece is disposed on an upper surface of the top cover of the second unfolded plane.

[0006] Optionally, an outer side cover extends outwards from an outer side of the top cover and is fitted with an outer side of a front wall of the packaging box.

[0007] Optionally, a magnet is disposed on an edge of the outer side cover and attracted to a magnet disposed on the front wall of the packaging box.

[0008] Optionally, two opposite edges of the first unfolded plane are fastened to form a box body of the packaging box.

[0009] A packaging box unfolded plate, which is configured to be folded and assembled to a packaging box, includes a first unfolded plane provided with folds, the first unfolded plane forms four side walls of the packaging box after being assembled along the folds, and one of the four side walls is a first side wall; and a second unfolded plane connected to the first side wall and extending along a lengthwise direction of the first side wall, the second unfolded plane is provided with folds, and the second unfolded plane forms a bottom plate, a second side wall and a top cover of the packaging box after being assembled along the folds.

[0010] Optionally, the bottom plate is a square.

[0011] Optionally, the first side wall faces to the second side wall after the packaging box is assembled.

[0012] Optionally, a base is disposed on a first surface of the bottom plate of the second unfolded plane and a

positioning piece is disposed on a first surface of the top cover of the second unfolded plane.

[0013] Optionally, the second unfolded plane is connected to a first end of the first side wall; and an outer side cover is disposed on a side of the top cover and fitted with a second end of the first side wall.

[0014] Optionally, a first magnet is disposed on an edge of the outer side cover and is attracted to a second magnet disposed on the first side wall.

[0015] Optionally, two opposite edges of the first unfolded plane, which are parallel to the lengthwise direction of the first side wall, are fastened to form the four side walls of the packaging box.

[0016] An assembling method for a packaging box includes: providing a first unfolded plane and a second unfolded plane connected to the first unfolded plane, the first unfolded plane is provided with folds; assembling the first unfolded plane along the folds and fastening two sides of the first unfolded plane to form four side walls of the packaging box, one of the four side walls is a first side wall, and the two sides are parallel to a lengthwise direction of the first side wall; assembling the second unfolded plane along folds to form a bottom plate, a second side wall and a top cover of the packaging box; the second unfolded plane extends along the lengthwise direction of the first side wall and is provided with the folds; and connecting the four side walls, the bottom plate, the second side wall and the top cover to form the packaging box.

[0017] Optionally, the bottom plate of the packaging box is a square.

[0018] Optionally, the first side wall of the packaging box faces to the second side wall.

[0019] Optionally, the assembling method further includes: disposing a base on a first surface of the bottom plate of the second unfolded plane; and disposing a positioning piece on a first surface of the top cover of the second unfolded plane.

[0020] Optionally, the second unfolded plane is connected to a first end of the first side wall; the packaging box further includes an outer side cover disposed on a side of the top cover, and the top cover is configured to fit with a second end of the first side wall.

[0021] Optionally, a first magnet is disposed on an edge of the outer side cover, a second magnet is disposed on an outer side of the second end of the first side wall, and the first magnet is configured to be attracted to the second magnet.

[0022] The packaging box provided by the present disclosure can prevent the bottom of the box from loosening and breaking, thereby ensuring the package reliability of the packaging box.

BRIEF DESCRIPTION OF DRAWINGS

[0023]

FIG. 1 is a plane view of a packaging box in an un-

folded state according to an embodiment;

FIG. 2 is a structure diagram of a base disposed on a bottom plate of a packaging box according to an embodiment;

FIG. 3 is a structure diagram of a bottle mouth positioning piece disposed on a top cover of a packaging box according to an embodiment; and

FIG. 4 is a flowchart of an assembling method of a packaging box according to an embodiment.

DETAILED DESCRIPTION

[0024] The solutions of the present disclosure are described hereinafter through embodiments in conjunction with the accompanying drawings.

[0025] As shown in FIG. 1, a packaging box according to the present embodiment includes a first unfolded plane 1 used to form a quadrangular cylinder, and a second unfolded plane 2 which is vertical to the first unfolded plane and extends from an edge of the first unfolded plane 1; the second unfolded plane 2 includes a bottom plate 21, a rear wall 22 and a top cover 23, which extend outwards in sequence.

[0026] A base 211 is disposed on an upper surface of the bottom plate 21 of the second unfolded plane 2, and a bottle mouth positioning piece 231 is disposed on an upper surface of the top cover 23 of the second unfolded plane 2; an outer side cover 24, which extends outwards from an outer side of the top cover 23, couples an outer side of a front wall 11 of the packaging box; a magnet 241 is disposed on the edge of the outer side cover 24, which is attracted to a magnet disposed on the front wall 11 of the packaging box; two opposite edges of the first unfolded plane 1 are fastened to form a body of the packaging box.

[0027] As shown in FIG. 1, the present embodiment further provides a packaging box unfolded plate used to be folded and assembled to a packaging box, which includes a first unfolded plane 1 provided with folds, where the first unfolded plane 1 is assembled along the folds and forms four side walls of the packaging box. One of four side walls is a first side wall; and a second unfolded plane 2 provided with folds, which is connected to a first side wall 11 and extends along the lengthwise direction of the first side wall 11, and forms a bottom plate 21, a second side wall 22 and a top cover 23, after being assembled along the folds. The packaging box according to the present embodiment can be used to pack a wine bottle or other articles. A packaging box for packaging a wine bottle is taken as an example for description in the embodiment.

[0028] Optionally, the bottom plate 21 is a square.

[0029] Optionally, after the first unfolded plane 1 and the second unfolded plane 2 are assembled, the first side wall 11 faces to the second side wall 22.

[0030] Optionally, a base 211 is disposed on the upper surface of the bottom plate 21 of the second unfolded plane and a bottle mouth positioning piece 231 is disposed on the upper surface of the top cover 23 of the second unfolded plane.

[0031] In the embodiment, when the packaging box is used to pack a wine bottle, the structure of the base 211 is as shown in FIG. 2 and the structure of the bottle mouth positioning piece 231 is as shown in FIG. 3. In FIG. 2, the base 211 includes a first surface 211a facing towards inner space of the packaging box, the first surface 211a is provided with a circular through hole 211b and the through hole 211b is used for holding the wine bottle, which can prevent the wine bottle from shaking by fixing the bottom of the bottle.

[0032] The bottle mouth positioning piece 231 includes a first surface 231a facing towards the inner space of the packaging box, the first surface 231a is provided with a circular through hole 231b and the through hole 231b is used for holding the wine bottle, which can prevent the wine bottle from shaking by fixing the mouth of the bottle.

[0033] The base 211 and the bottle mouth positioning piece 231 may be a solid cuboid or a hollow cuboid.

[0034] When the packaging box in the embodiment is used for packing other articles, the through holes in the base 211 and the bottle mouth positioning piece 231 may be in other shapes to fit with the shape of the article in the packaging box, so that these through holes can fix the article and prevent the article from shaking.

[0035] Optionally, the second unfolded plane is connected to the first end of the first side wall.

[0036] An outer side cover 24 extends outwards from the outer side of the top cover 23 and the outer side cover 24 couples a second end of the first side wall 11.

[0037] Optionally, the first magnet 241 is disposed on the edge of the outer side cover 24, which is attracted to the second magnet (not shown) disposed on the first side wall 11.

[0038] Optionally, two opposite edges of the first unfolded plane 1, which are parallel to the lengthwise direction of the first side wall, form the four side walls of the packaging box after being fastened.

[0039] As shown in FIG. 4, an embodiment further provides an assembling method for a packaging box. The method is used to fold and assemble the above-mentioned unfolded plane into the packaging box. The method includes the following steps.

[0040] In step 410, a first unfolded plane and a second unfolded plane connected to the first unfolded plane are provided.

[0041] Herein the first unfolded plane is provided with folds; the first unfolded plane is assembled along the folds and two sides of the first unfolded plane are fastened to form four side walls of the packaging box. One of four side walls is the first side wall, and the two sides are parallel to a lengthwise direction of the first side wall.

[0042] In step 420, the second unfolded plane is assembled along the folds to form a bottom plate, a second

side wall and a top cover.

[0043] Herein, the second unfolded plane extends along the lengthwise direction of the first side wall and is provided with folds.

[0044] In step 430, four side walls, the bottom plate, the second side and the top cover are connected to form the packaging box.

[0045] Herein the bottom plate of the packaging box is a square. The first side wall of the packaging box faces to the second side wall.

[0046] The assembling method of the packaging box provided by the embodiment further includes the step 440.

[0047] In step 440, a base is disposed on a first surface of the bottom plate of the second unfolded plane and a bottle mouth positioning piece is disposed on a first surface of the top cover of the second unfolded plane.

[0048] Herein a second unfolded plane connected with a first end of the first side wall, and an outer side cover disposed on a side of the top cover is also included in the packaging box and is configured to fit with a second end of the first side wall.

[0049] Herein a first magnet is disposed on an edge of the outer side cover, a second magnet is disposed on an outer side of a second end of the first side wall and the first magnet is attracted to the second magnet.

[0050] When the packaging box unfolded plate is assembled, the upper edge 12 and the lower edge 13 of the first unfolded plane are fastened, to form the box body for storing the wine bottle; the second unfolded plane is folded sequentially from the bottom plate until the outer side cover 24 can be fitted with the first side wall 11 of the packaging box. The packaging box configured in the above-mentioned manner can prevent the bottom of the box from loosening and breaking, ensuring the package reliability of the packaging box; besides, the base and the bottle mouth positioning piece can fix the wine bottle and prevent the bottle from breaking due to the shaking during the transportation. The packaging box designed in the above-mentioned manner can be obtained through the integrated cutting of a cardboard and then folded according to the above method, which is convenient and efficient and saves both time and labor. After finished, the packaging box described in the above embodiment can spread out to the minimum volume during the transportation, saving a large amount of transport cost and ensuring the transportation safety. This method solves the problem of high transport cost in the related art, where the well-finished box is three-dimensional and cannot be spread out.

INDUSTRIAL APPLICABILITY

[0051] The packaging box, a packaging box unfolded plate and an assembling method, provided by the present disclosure can prevent the bottom of the packaging box from loosening and breaking and ensure package reliability of the packaging box.

Claims

1. A packaging box, comprising a first unfolded plane for forming a quadrangular cylinder; and a second unfolded plane being vertical to the first unfolded plane and extending from an edge of the first unfolded plane, wherein the second unfolded plane comprises a bottom plate, a rear wall and a top cover, which extend outwards in sequence.
2. The packaging box according to claim 1, wherein a base is disposed on an upper surface of the bottom plate of the second unfolded plane and a positioning piece is disposed on an upper surface of the top cover of the second unfolded plane.
3. The packaging box according to claim 1, wherein an outer side cover extends outwards from an outer side of the top cover and is fitted with an outer side of a front wall of the packaging box.
4. The packaging box according to claim 3, wherein a magnet is disposed on an edge of the outer side cover and attracted to a magnet disposed on the front wall of the packaging box.
5. The packaging box according to claim 1, wherein two opposite edges of the first unfolded plane are fastened to form a box body of the packaging box.
6. A packaging box unfolded plate, which is configured to be folded and assembled to a packaging box, comprising: a first unfolded plane provided with folds, wherein the first unfolded plane forms four side walls of the packaging box after being assembled along the folds, and one of the four side walls is a first side wall; and a second unfolded plane connected to the first side wall and extending along a lengthwise direction of the first side wall, wherein the second unfolded plane is provided with folds, and the second unfolded plane forms a bottom plate, a second side wall and a top cover of the packaging box after being assembled along the folds.
7. The packaging box unfolded plate according to claim 6, wherein the bottom plate is a square.
8. The packaging box unfolded plate according to claim 7, wherein the first side wall faces to the second side wall after the packaging box is assembled.
9. The packaging box unfolded plate according to claim 8, wherein a base is disposed on a first surface of the bottom plate of the second unfolded plane and a positioning piece is disposed on a first surface of the top cover of the second unfolded plane.

10. The packaging box unfolded plate according to claim 8, wherein the second unfolded plane is connected to a first end of the first side wall; and an outer side cover is disposed on a side of the top cover and fitted with a second end of the first side wall. 5
11. The packaging box unfolded plate according to claim 10, wherein a first magnet is disposed on an edge of the outer side cover and is attracted to a second magnet disposed on the first side wall. 10
12. The packaging box unfolded plate according to claim 8, wherein two opposite edges of the first unfolded plane, which are parallel to the lengthwise direction of the first side wall, are fastened to form the four side walls of the packaging box. 15
13. An assembling method for a packaging box, comprising: providing a first unfolded plane and a second unfolded plane connected to the first unfolded plane, wherein the first unfolded plane is provided with folds; assembling the first unfolded plane along the folds and fastening two sides of the first unfolded plane to form four side walls of the packaging box, wherein one of the four side walls is a first side wall, and the two sides are parallel to a lengthwise direction of the first side wall; assembling the second unfolded plane along folds to form a bottom plate, a second side wall and a top cover of the packaging box; wherein the second unfolded plane extends along the lengthwise direction of the first side wall and is provided with the folds; and connecting the four side walls, the bottom plate, the second side wall and the top cover to form the packaging box. 20
25
30
35
14. The method according to claim 13, wherein the bottom plate of the packaging box is a square. 40
15. The method according to claim 13, wherein the first side wall of the packaging box faces to the second side wall.
16. The method according to claim 13, further comprising: disposing a base on a first surface of the bottom plate of the second unfolded plane; and disposing a positioning piece on a first surface of the top cover of the second unfolded plane. 45
50
17. The method according to claim 13, wherein the second unfolded plane is connected to a first end of the first side wall; the packaging box further comprises an outer side cover disposed on a side of the top cover, and the top cover is configured to fit with a second end of the first side wall. 55
18. The method according to claim 17, wherein a first magnet is disposed on an edge of the outer side cover, a second magnet is disposed on an outer side of the second end of the first side wall, and the first magnet is configured to be attracted to the second magnet.

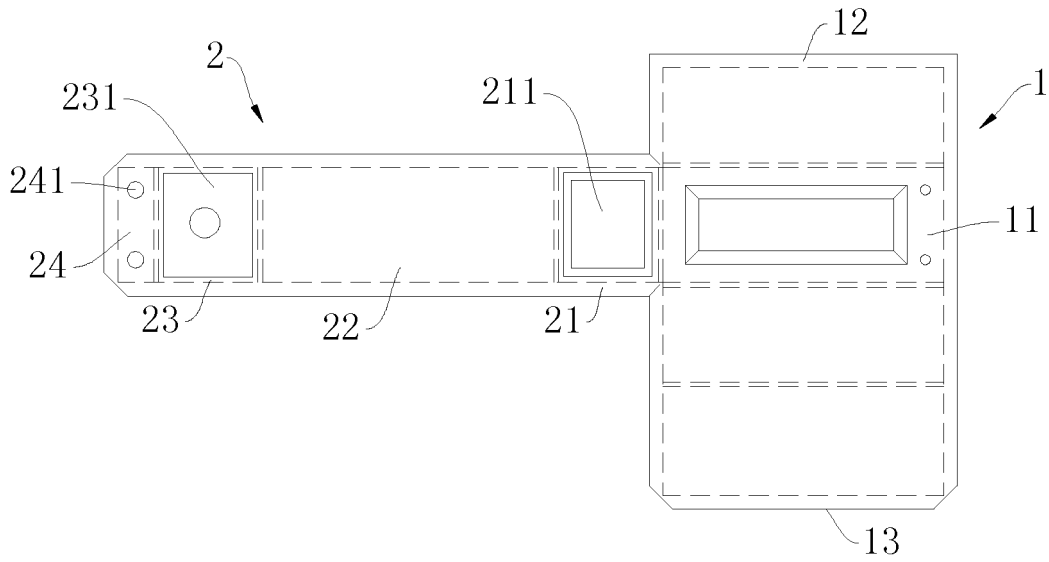

FIG.1

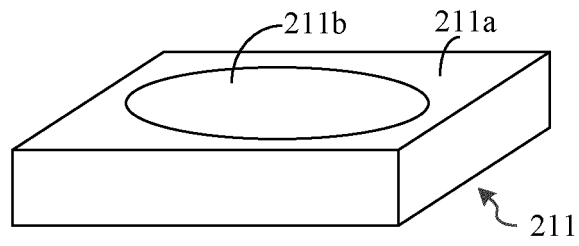

FIG.2

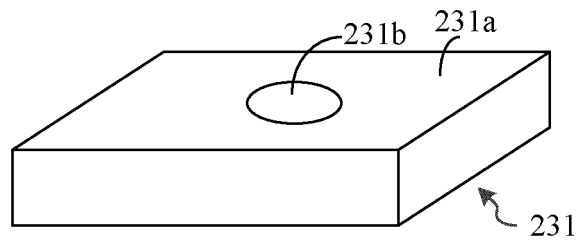

FIG.3

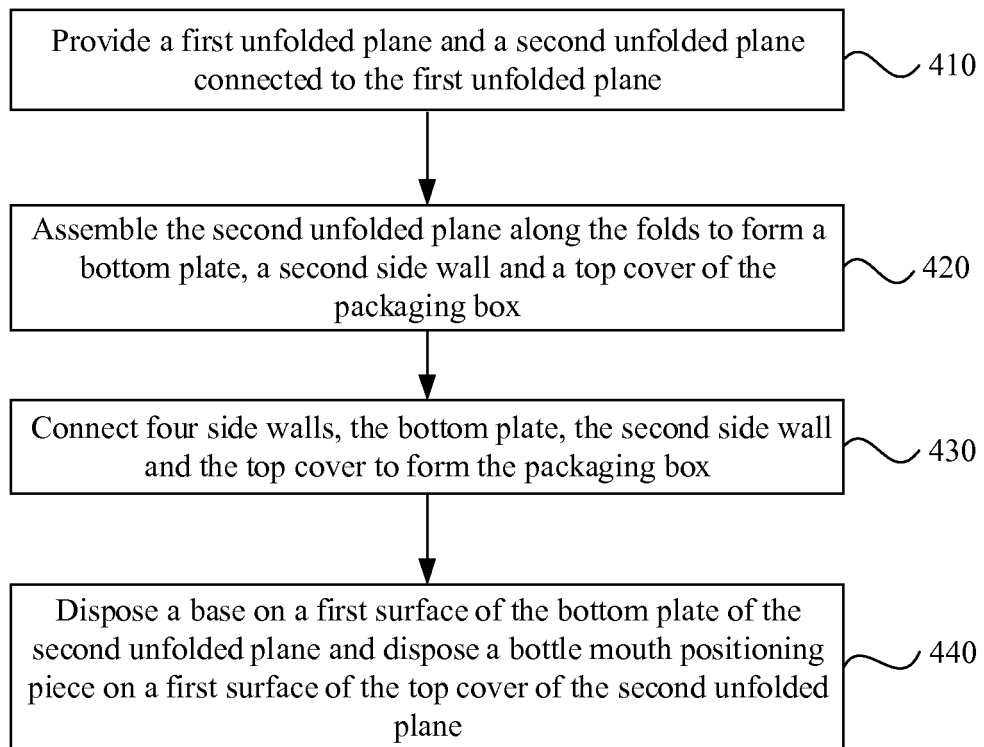

FIG.4

INTERNATIONAL SEARCH REPORT

International application No.
PCT/CN2017/102513

A. CLASSIFICATION OF SUBJECT MATTER				
B65D 5/20 (2006.01) i				
According to International Patent Classification (IPC) or to both national classification and IPC				
B. FIELDS SEARCHED				
Minimum documentation searched (classification system followed by classification symbols)				
B65D				
Documentation searched other than minimum documentation to the extent that such documents are included in the fields searched				
Electronic data base consulted during the international search (name of data base and, where practicable, search terms used)				
CNABS, SIPOABS, CNKI: 盒, 箱, 酒瓶, T, 丁, 字型, 字形, 垂直, 侧板, 圆孔, 磁铁; box, container, bottle, sidewall, vertical+, perpendicular, magnet				
C. DOCUMENTS CONSIDERED TO BE RELEVANT				
Category*	Citation of document, with indication, where appropriate, of the relevant passages	Relevant to claim No.		
X	CN 201071131 Y (TIANJIN YIYAO PRINTING CO., LTD.), 11 June 2008 (11.06.2008), description, page 2, lines 8-12, and figures 1-2	1-18		
A	CN 102910335 A (CHENGLU PAPER PRODUCTS MFG. CO., LTD.), 06 February 2013 (06.02.2013), entire document	1-18		
A	CN 205203594 U (WANG, Xianyun), 04 May 2016 (04.05.2016), entire document	1-18		
A	JP 10119956 A (SAKAMOTO INSATSU KK), 12 May 1998 (12.05.1998), entire document	1-18		
A	CN 2350321 Y (LI, Shubin), 24 November 1999 (24.11.1999), entire document	1-18		
A	CN 201801071 U (LI, Xiaogang), 20 April 2011 (20.04.2011), entire document	1-18		
A	CN 1177327 A (THE MEAD CORPORATION), 25 March 1998 (25.03.1998), entire document	1-18		
<input type="checkbox"/> Further documents are listed in the continuation of Box C. <input checked="" type="checkbox"/> See patent family annex.				
* Special categories of cited documents: <table border="0" style="width: 100%;"> <tr> <td style="width: 50%; vertical-align: top;"> <p>“A” document defining the general state of the art which is not considered to be of particular relevance</p> <p>“E” earlier application or patent but published on or after the international filing date</p> <p>“L” document which may throw doubts on priority claim(s) or which is cited to establish the publication date of another citation or other special reason (as specified)</p> <p>“O” document referring to an oral disclosure, use, exhibition or other means</p> <p>“P” document published prior to the international filing date but later than the priority date claimed</p> </td> <td style="width: 50%; vertical-align: top;"> <p>“T” later document published after the international filing date or priority date and not in conflict with the application but cited to understand the principle or theory underlying the invention</p> <p>“X” document of particular relevance; the claimed invention cannot be considered novel or cannot be considered to involve an inventive step when the document is taken alone</p> <p>“Y” document of particular relevance; the claimed invention cannot be considered to involve an inventive step when the document is combined with one or more other such documents, such combination being obvious to a person skilled in the art</p> <p>“&” document member of the same patent family</p> </td> </tr> </table>			<p>“A” document defining the general state of the art which is not considered to be of particular relevance</p> <p>“E” earlier application or patent but published on or after the international filing date</p> <p>“L” document which may throw doubts on priority claim(s) or which is cited to establish the publication date of another citation or other special reason (as specified)</p> <p>“O” document referring to an oral disclosure, use, exhibition or other means</p> <p>“P” document published prior to the international filing date but later than the priority date claimed</p>	<p>“T” later document published after the international filing date or priority date and not in conflict with the application but cited to understand the principle or theory underlying the invention</p> <p>“X” document of particular relevance; the claimed invention cannot be considered novel or cannot be considered to involve an inventive step when the document is taken alone</p> <p>“Y” document of particular relevance; the claimed invention cannot be considered to involve an inventive step when the document is combined with one or more other such documents, such combination being obvious to a person skilled in the art</p> <p>“&” document member of the same patent family</p>
<p>“A” document defining the general state of the art which is not considered to be of particular relevance</p> <p>“E” earlier application or patent but published on or after the international filing date</p> <p>“L” document which may throw doubts on priority claim(s) or which is cited to establish the publication date of another citation or other special reason (as specified)</p> <p>“O” document referring to an oral disclosure, use, exhibition or other means</p> <p>“P” document published prior to the international filing date but later than the priority date claimed</p>	<p>“T” later document published after the international filing date or priority date and not in conflict with the application but cited to understand the principle or theory underlying the invention</p> <p>“X” document of particular relevance; the claimed invention cannot be considered novel or cannot be considered to involve an inventive step when the document is taken alone</p> <p>“Y” document of particular relevance; the claimed invention cannot be considered to involve an inventive step when the document is combined with one or more other such documents, such combination being obvious to a person skilled in the art</p> <p>“&” document member of the same patent family</p>			
Date of the actual completion of the international search		Date of mailing of the international search report		
10 December 2017		15 January 2018		
Name and mailing address of the ISA State Intellectual Property Office of the P. R. China No. 6, Xitucheng Road, Jimenqiao Haidian District, Beijing 100088, China Facsimile No. (86-10) 62019451		Authorized officer GONG, Jianhong Telephone No. (86-10) 62085265		

Form PCT/ISA/210 (second sheet) (July 2009)

INTERNATIONAL SEARCH REPORT
 Information on patent family members

 International application No.
 PCT/CN2017/102513

5

10

15

20

25

30

35

40

45

50

Patent Documents referred in the Report	Publication Date	Patent Family	Publication Date
CN 201071131 Y	11 June 2008	None	
CN 102910335 A	06 February 2013	None	
CN 205203594 U	04 May 2016	None	
JP 10119956 A	12 May 1998	JP H10119956 A	12 May 1998
CN 2350321 Y	24 November 1999	None	
CN 201801071 U	20 April 2011	None	
CN 1177327 A	25 March 1998	EP 1652788 A3	14 April 2010
		KR 100371048 B1	14 August 2003
		PL 321075 A1	24 November 1997
		HU 9901156 A2	30 August 1999
		DE 69607931 D1	31 May 2000
		EP 0950617 A3	27 October 1999
		MX 9705184 A	31 October 1997
		EP 0950617 A2	20 October 1999
		AT 361243 T	15 May 2007
		ES 2144727 T3	16 June 2000
		HU 9901156 A3	29 January 2001
		NO 973196 A	01 September 1997
		SK 89897 A3	04 February 1998
		CZ 294321 B6	10 November 2004
		CZ 9702108 A3	14 October 1998
		DE 69637066 T2	10 January 2008
		NZ 301970 A	28 October 1998
		EP 0800479 B1	26 April 2000
		DK 0800479 T3	07 August 2000
		JP 2001527488 A	25 December 2001
		NO 973196 D0	09 July 1997
		RU 2158704 C2	10 November 2000
		GR 3033976 T3	30 November 2000
		WO 9621603 A1	18 July 1996
		PT 800479 E	31 August 2000
		SK 283511 B6	05 August 2003
		EP 0950617 B1	02 May 2007
		DE 69607931 T2	17 August 2000
		PL 179808 B1	31 October 2000
		DK 0950617 T3	10 September 2007
		DE 69637066 D1	14 June 2007
		NO 311972 B1	25 February 2002
		BR 9606748 A	06 January 1998
		AT 192108 T	15 May 2000
		CA 2209287 A1	18 July 1996
		CN 1082009 C	03 April 2002
		HK 1023324 A1	20 July 2007
		PT 800479 T	31 August 2000
		EP 1652788 A2	03 May 2006
		EP 0800479 A1	15 October 1997
		CA 2209287 C	23 July 2002
		ES 2287993 T3	16 December 2007
		GB 9500428 D0	01 March 1995

Form PCT/ISA/210 (patent family annex) (July 2009)

55