



(12) **EUROPEAN PATENT APPLICATION**

(43) Date of publication:
06.03.2019 Bulletin 2019/10

(51) Int Cl.:
A47B 3/08 (2006.01) A47B 3/091 (2006.01)

(21) Application number: **18189210.0**

(22) Date of filing: **15.08.2018**

(84) Designated Contracting States:
AL AT BE BG CH CY CZ DE DK EE ES FI FR GB GR HR HU IE IS IT LI LT LU LV MC MK MT NL NO PL PT RO RS SE SI SK SM TR
 Designated Extension States:
BA ME
 Designated Validation States:
KH MA MD TN

(71) Applicant: **Gopak Limited**
Hythe, Kent CT21 6HG (GB)

(72) Inventor: **McCaffrey, Andrew**
Reading, Berkshire RG6 5UD (GB)

(74) Representative: **Bridge-Butler, Jeremy**
Baron Warren Redfern
1000 Great West Road
Brentford TW8 9DW (GB)

(30) Priority: **01.09.2017 GB 201714026**

(54) **FURNITURE LEG ASSEMBLY**

(57) A furniture leg assembly comprising a leg, a securing element for securing said leg assembly to an item of furniture with which it is used, and a support element disposed substantially adjacent to said leg, in which said leg is rotationally attached to a first part of said securing element and is rotatable about a point from a stored position to a supporting position in which said leg extends at an angle to a longitudinal axis of said securing element, in which an outer end of said support element is attached to said leg such that a biasing force biases an inner end of said support element towards said leg, in which said support element comprises a transverse portion extending in a transverse direction from said inner end, which

transverse portion is disposed adjacent to said first part when said leg is in the stored position, and moves over a top surface of said first part into a distal locking part of said securing element when said leg rotates from said stored position to said support position, in which said distal locking part comprises a socket for releasably retaining said transverse portion, said socket being spaced from said point so said biasing force biases said transverse portion into said socket, and in which said distal locking part comprises a stop wall opposite to said socket, which delimits a distance said transverse portion can travel out from said socket.

Figure 1

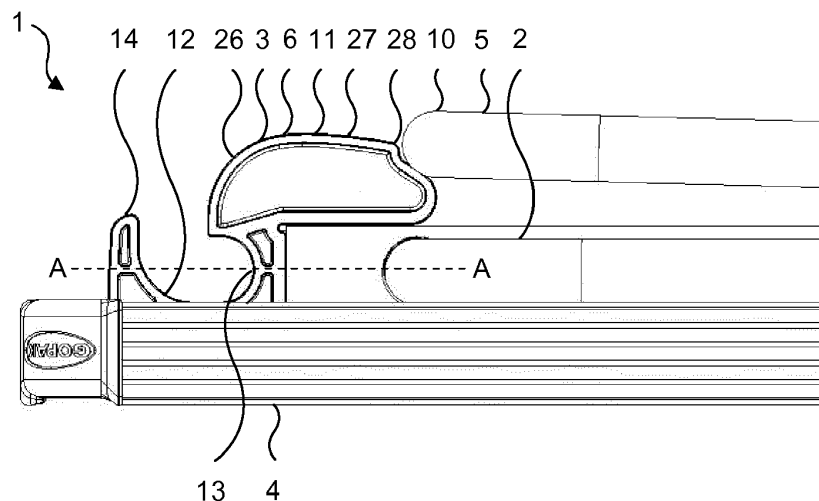

Description

[0001] The present invention relates to a furniture leg assembly, for use particularly, but not exclusively, as a leg assembly for a folding table.

[0002] Collapsible legs for use with folding tables and chairs and the like are well known. The inner ends of the legs can be attached in a hinged arrangement to the underside of the body of the item of furniture, so that they can be folded up underneath the body for storage. There are many known types of folding mechanisms which utilise a variation of designs.

[0003] The chief aims of any folding mechanism are twofold. Firstly, the mechanism must be able to adequately support the leg when it is extended, so that the table or other article will not collapse during use. Secondly, the mechanism must facilitate ease of use, so that the leg can be readily extended and collapsed.

[0004] One design which has proved successful comprises a pair of legs constructed from a single U-shaped component, in which the transverse interconnecting portion is attached in a hinged arrangement to the underside of the table. The legs are provided with a support element which is substantially the same size and shape to the legs component, and which is disposed alongside the legs. The two components are rigidly attached together at their outer ends in such a way that the two adjacent transverse interconnecting portions are resiliently biased together, but can be manually pulled apart.

[0005] When the legs are unfolded the transverse interconnecting portion of the support element is pulled away from the legs and placed in sockets provided on the underside of the table. With this arrangement the biasing together of the transverse interconnecting portions holds that of the support element in the sockets. When the table needs to be folded up for storage, the support element can be removed from the sockets by hand, and the two connected components can be folded flat against the underside of the table top.

[0006] One problem with this design of leg assembly is that the resilient force which biases the leg component and the support element together can be weakened over time, and in particular if the components, or the parts which connect them together, are damaged as a result of the support element being pulled too far apart from the leg component in use. This happens in particular when users reach under the table top to remove the transverse portion of the support element from the sockets. A break out force is required to remove the transverse portion of the support element from the sockets, and once this is achieved and the transverse portion released, there is a tendency for it to then travel further than intended, and over extend the components, or the parts which connect them together, and thereby weaken the resilient force which biases them together.

[0007] GB2392204 in the name of the applicant addresses this problem by providing the transverse portion of the support element with a sleeve with a slide pin

extending therefrom, which is located in a slide and along which it moves when the leg is rotated. The slide is curved to follow the path of the transverse portion of the support element when the leg is rotated. This arrangement prevents the transverse portion of the support element ever being pulled too far apart from the leg component. However, the construction shown in GB2392204 is not without its own problems. In particular, it requires the additional sleeve component which adds cost and complexity, and the resistance provided by the sleeve rotating on the transverse portion of the support element, as well as the slide pin moving through the slide, increases the force required to rotate the leg. Further, the pressure placed on the slide pin when the transverse portion of the support element is pulled from the sockets by the user can cause it to break, or to come loose from the slide.

[0008] The present invention is intended to overcome some of the above described problems.

[0009] Therefore, according to a first aspect of the present invention a furniture leg assembly comprises a leg, a securing element for securing said leg assembly to an item of furniture with which it is used, and a support element disposed adjacent to said leg, in which said leg is rotationally attached to a first part of said securing element and is rotatable about a point from a stored position to a supporting position in which said leg extends at an angle to a longitudinal axis of said securing element, in which an outer end of said support element is attached to said leg such that a biasing force biases an inner end of said support element towards said leg, in which said support element comprises a transverse portion extending in a transverse direction from said inner end, which transverse portion is disposed adjacent to said first part when said leg is in the stored position, and moves over a top surface of said first part into a distal locking part of said securing element when said leg rotates from said stored position to said supporting position, in which said distal locking part comprises a socket for releasably retaining said transverse portion, said socket being spaced from said point so said biasing force biases said transverse portion into said socket, and in which said distal locking part comprises a stop wall opposite to said socket, which delimits a distance said transverse portion can travel out from said socket.

[0010] Thus, the present invention provides a furniture leg assembly like that shown in GB2392204, but which addresses the issue of preventing the transverse portion of the support element being pulled too far from the leg by providing the stop wall. This addresses the main cause of damage being caused to these kinds of furniture leg assembly, which as explained above generally occurs when users pull the transverse portion out from the socket.

[0011] As explained further below, this invention finds particular application as a table leg assembly in which the leg is part of a U-shaped two leg component, a transverse interconnecting portion of which is hinged to the underside of the table. The support element can be part

of a U-shaped two support element component of substantially the same shape, which can be disposed alongside the leg component. The two components can be fixed together at their outer ends, in such a way that the two transverse interconnecting portions are resiliently biased together, but can be pulled apart. A furniture leg assembly comprising one leg, one securing element and one support element like that described in the statement of invention above can be provided at both sides of such a two leg construction. However, it will be appreciated that because it is also possible to provide an isolated furniture leg assembly comprising one leg, one securing element and one support element, such a configuration is the initial emphasis of this description. The application of the invention as one of two such assemblies on either side of a table, is explained in further detail later.

[0012] Preferably the distal locking part can comprise a connecting portion which connects an inner surface of the socket to the stop wall, and at least a section of the connecting portion and/or the stop wall can be curved. With this configuration the connecting portion and the stop wall can act as a guide surface to guide the transverse portion into and out of the socket.

[0013] The transverse portion can be any cross-sectional shape, but preferably it can comprise a circular cross-section, and the inner surface can be curved to matingly engage the transverse portion.

[0014] Therefore, a continuously curved surface can be provided from a top of the stop wall around to the highest part of the socket, and the distal locking part can form a substantially L-shaped interface for the transverse portion, which simultaneously guides it into and out of the socket, and delimits the amount the transverse portion can travel away from the point.

[0015] The top surface can comprise an abutment for restricting free movement of the transverse portion when it is disposed adjacent to the first part when the leg is in the stored position. The biasing force can bias the transverse portion into a locked position behind the abutment. This occurs because the biasing force acts on the transverse portion at all times. The biasing force can also bias the transverse portion into direct engagement with the top surface when moving between the first part and the distal locking part. In contrast to the arrangement shown in GB2392204 the transverse portion can be manually lifted away from the top surface, but this is not considered to be a drawback and this does not occur often in use. Usually a user rotates the leg directly, and if so the transverse portion remains in contact with the top surface as a result of the presence of the biasing force.

[0016] The top surface can be any suitable shape, but preferably it can be convex. A socket end section of the top surface can be curved to a higher degree than a first part end of the top surface. With this arrangement the amount of manual force required to move the leg from the stored position to the support position decreases the further it travels, and the greater the angle achieved between the leg and the longitudinal axis of the securing

element, which in use will be parallel to a table top or the like.

[0017] The leg can be rotatably mounted to the securing element at the point in any suitable manner. However, preferably the leg can comprise a transverse boss extending in a transverse direction from an inner end thereof, the transverse boss being parallel with the transverse portion. The transverse boss can be arranged in a transverse aperture provided in the first part in order to facilitate its rotational movement. (It will be appreciated that rather than having an end, the transverse boss will be an end section of an interconnecting transverse portion of a U-shaped two leg component, as described above.)

[0018] The securing element can be connectable to an item of furniture in any known way, such as with screws, bolts or adhesive. However, preferably the first part can comprise an engagement portion for affixing it to an item of furniture with which it is used, the engagement portion comprising the male part of an engagement mechanism. Preferably the transverse aperture can be provided in the male part. This arrangement is suitable for use with table frames which comprise a longitudinally arranged open-ended box section, into which the engagement portion can be slotted. The box section can have opposed apertures between which the transverse aperture can be located when the engagement portion is placed in the end of the box section, and the transverse boss can pass through the opposed apertures and the transverse aperture in order to secure the engagement section in place.

[0019] Centres of the transverse aperture and the socket can both be located on the longitudinal axis. What this means is that the transverse portion is aligned with the transverse boss when the leg is in the support position.

[0020] When the transverse portion is disposed in the socket the leg can extend at an angle to the longitudinal axis which is substantially 90 degrees or greater.

[0021] As mentioned above, the invention finds application as a furniture leg assembly provided at one corner of a table. Therefore, in one version of the invention the leg can be part of a U-shaped two leg component and the support element can be part of a U-shaped two support element component which can be substantially the same shape as the U-shaped two leg component and can be disposed adjacent to the U-shaped two leg component. The U-shaped two leg component and the U-shaped two support element component can be fixed together at their outer ends, such that transverse interconnecting portions of the U-shaped two leg component and the U-shaped two support element component can be biased together. The securing element can comprise a first securing element provided at one side of the furniture leg assembly and the leg can comprise a first leg of the U-shaped two leg component. Furthermore a second securing element identical to the first securing element can then be provided at a second side of the furniture leg assembly and can rotationally support a second leg of the U-shaped two leg component.

[0022] The invention also includes an item of furniture comprising a furniture leg assembly as described above.

[0023] Therefore, according to a second aspect of the present invention an item of furniture comprises a furniture leg assembly of any of claims 1 to 12 below, in which said securing element is secured to an underside of a platform of said item of furniture, such that said leg is disposed in a plane substantially parallel to said platform in the stored position, and such that said leg extends at an angle to said platform which is substantially 90 degrees or greater in the supporting position.

[0024] The item of furniture can be a table, bench or seat.

[0025] The present invention can be performed in various ways, but one embodiment will now be described by way of example and with reference to the accompanying drawings, in which:

Figure 1 is a side view of a furniture leg assembly according to the first aspect of the present invention in use as part of a table (only a section of which is shown) and with a leg part thereof in a stored position;

Figure 2 is a side view of a furniture leg assembly as shown in Figure 1 with a leg part thereof in a support position, and with some components shown in cross-section;

Figure 3 is a side view of a securing element part of the furniture leg assembly as shown in Figure 1;

Figure 4 is a perspective view of the furniture leg assembly as shown in Figure 1 in use as part of a table (only a section of which is shown) with the leg part thereof in the stored position; and

Figure 5 is a perspective view of a table according to the second aspect of the present invention, with leg parts thereof in support positions.

[0026] As shown in the Figures a furniture leg assembly 1 comprises a leg 2, a securing element 3 for securing the leg assembly 1 to an item of furniture with which it is used, in the form of table 4, and a support element 5 disposed adjacent to the leg 2. The support element 5 is at a slight angle to the leg 2 because it is forced apart from the leg 2 by the shape of the securing element 3 disposed between them, to different degrees in different positions of the leg 2, as described further below. The leg 2 is rotationally attached to a first part 6 of the securing element 3 and is rotatable about a point 7 from a stored position, as shown in Figures 1 and 4, to a supporting position, as shown in Figures 2 and 5, in which the leg 2 extends at an angle to a longitudinal axis A-A of the securing element 3. The leg 2 is arranged at an angle to the longitudinal axis A-A which is slightly greater than 90 degrees, as explained further below. (The leg 2 is not

visible in Figure 2, because the U-shaped two leg component 41 of which it forms a part is shown in Figure 2 in cross-section. The leg which is visible in Figure 2 is second leg 43 on the other side of the table 4, as described further below.)

[0027] An outer end 8 of the support element 5 (visible only in Figure 5) is attached to the leg 2 such that a biasing force biases an inner end 9 of the support element 5 towards the leg 2.

[0028] The support element 5 comprises a transverse portion 10, best seen in Figure 4, which extends in a transverse direction from the inner end 9, and which is disposed adjacent to the first part 6 when the leg 2 is in the stored position as shown in Figure 1, and which moves over a top surface 11 of the first part 6 into a distal locking part 12 of the securing element 3 when the leg 2 rotates from the stored position to the supporting position as shown in Figures 2 and 5. The distal locking part 12 comprises a socket 13 for releasably retaining the transverse portion 10, the socket 13 being spaced from the point 7 so the biasing force biases the transverse portion 10 into the socket 13. The distal locking part 12 comprises a stop wall 14 opposite to the socket 13, which delimits a distance the transverse portion 10 can travel out from said socket 13.

[0029] As shown in Figure 3, the securing element 3 is a single component made from a moulded plastics material. It comprises the first part 6 and the distal locking part 12. The first part 6 comprises an engagement portion 15.

[0030] The distal locking part 12 comprises the socket 13 and the stop wall 14, as well as a connecting portion 16 therebetween. An inner surface 17 of the socket 13 is shaped as substantially half of a circle with a short linear section 18 before it. An upper surface 19 of the connecting portion 16 comprises a flat section 20 leading to a curved section 21, and a side surface 22 of the stop wall 14 comprises a curved section 23 leading to a flat section 24. Collectively the inner surface 17, the upper surface 19 and the side surface 22 form a guide surface 25 to guide the transverse portion 10 into and out of the socket 13.

[0031] The transverse portion 10 has a circular cross-section, as shown in Figure 2, which is shaped to matingly engage the inner surface 17 of the socket 13, and to ride smoothly over the guide surface 25, and the top surface 11.

[0032] With this configuration the distal locking part 12 forms a substantially L-shaped interface for the transverse portion 10, which simultaneously guides it into and out of the socket 13, and delimits the amount the transverse portion 10 can travel away from the point 7.

[0033] The top surface 11 is convex and is designed for the transverse portion 10 to ride over when the leg 2 moves between the stored position and supporting position shown in Figures 1 and 2 respectively. The biasing force biases the transverse portion 10 into engagement with the top surface 11 when this happens, although it is

possible to manually lift the transverse portion 10 away from the top surface 11.

[0034] A socket end section 26 of the top surface 11 is curved to a higher degree than a first part end 27 of the top surface 11. With this arrangement the amount of manual force required to move the leg 2 from the stored position to the supporting position decreases the further it travels, and the greater the angle achieved between the leg 2 and the longitudinal axis A-A of the securing element 3 (and vice versa).

[0035] The support element 5 is forced further away from the point 7 as it rides anti-clockwise over the first part end 27, before reaching a distance from the point 7 which is substantially maintained as it rides anti-clockwise over the socket end section 26. When it reaches the end of the top surface 11 the transverse portion 10 drops into the socket 13 as a result of the biasing force. This shape of top surface 11 makes the furniture leg assembly 1 easier and more intuitive to manipulate in use. The leg 2 is harder to unfurl at first before the assembly 1 presents a consistent resistance to leg rotation, and then the leg 2 snaps into the supporting position. When the leg 2 is being collapsed after the support element 5 has been withdrawn from the socket 13, the assembly 1 presents a consistent resistance to leg rotation, before then reducing that resistance as the leg 2 moves closer to the stored position.

[0036] The top surface 11 comprises an abutment 28 for restricting free movement of the transverse portion 10 when it is disposed adjacent to the first part 6 when the leg 2 is in the stored position, as shown in Figure 1. This prevents the leg 2 from moving from the stored position unintentionally. The biasing force biases the transverse portion 10 into a locked position behind the abutment 28, because it acts on the transverse portion 10 at all times. Therefore, to move the leg 2 from the stored position the user has to apply sufficient manual force to lift the transverse portion 10 over the abutment 28. Further, when the user is moving the leg 2 back to the stored position the transverse portion 10 rides over the top surface 11 until it reaches the abutment 28, which it has to travel over to reach the locked position, as shown in Figure 1.

[0037] As best seen in Figures 4 and 5 the leg 2 comprises a transverse boss 29 extending in a transverse direction from an inner end 30 thereof, the transverse boss 29 being parallel with the transverse portion 10. As shown in Figure 2, the transverse boss 29 is arranged in a transverse aperture 31 provided in the engagement portion 15 of the first part 6 in order to facilitate its rotational movement. As such, the leg 2 is arranged alongside the securing element 3 rather than being co-planar with it.

[0038] Centres 32 and 31 of the transverse aperture 31 and the socket 13 are both located on the longitudinal axis A-A (the centre of the socket 13 being the centre of a circle which defines the curved inner surface 17 of the socket 13). What this means is that the transverse portion 10 is axially aligned with the transverse boss 29 when

the leg 2 is in the supporting position as shown in Figure 2. The support element 5 is actually slightly shorter than the leg 2, so when the transverse portion 10 is disposed in the socket 13 the leg 2 extends at an angle to the longitudinal axis A-A which is slightly greater than 90 degrees. (This is clear from Figure 2 because the second leg 43 can be seen to be at this angle.) This ensures the leg 2 is arranged at a stable and safe angle in use.

[0039] The engagement portion 15 is a substantially rectangular male part 34 of an engagement mechanism. In particular, it is designed to be located in the end of an open-ended box section 35 of a table frame 36, as it is in Figures 1 and 2. A longitudinal gap 37 is provided between the engagement portion 15 and the remainder of the first part 6, so the remainder of the first part 6 is disposed on an underside 38 of the box section 35 when the engagement portion 15 is located in the end of the box section 35.

[0040] The box section 35 has opposed apertures, one of which 39 is visible in the Figures, between which the transverse aperture 31 is located when the engagement portion 15 is placed in the end of the box section 35. The transverse boss 29 then passes through the opposed apertures 39 and the transverse aperture 31 in order to secure the engagement section 15 in place.

[0041] It will be appreciated that rather than having an end, the transverse boss 29 is actually an end section of an interconnecting transverse portion 40 of a U-shaped two leg component 41, of which the leg 4 is only one section. The first aspect of the present invention relates to one furniture leg assembly controlling one leg as described above, but in practice the furniture leg assembly 1 controls two legs, and two such furniture leg assemblies 1 can be used when the invention is applied to a table 4 with four legs.

[0042] As such, in the embodiment shown in the Figures the interconnecting transverse portion 40 of the U-shaped two leg component 41 is hinged to an underside 42 of the table 4 in the manner as described above on both sides thereof. The leg 2 comprises a first leg of the U-shaped two leg component 41, which also has second leg 43. Following on from this the support element 5 is part of a U-shaped two support element component 44 which is substantially the same shape as the U-shaped two leg component 41 and is disposed adjacent to it. The U-shaped two support element component 44 comprises the support element 5, the transverse portion 10 as an interconnecting transverse portion 45 thereof, and a second support element 46.

[0043] The U-shaped two leg component 41 and the U-shaped two support element component 44 are fixed together at their outer ends 8 and 47 and 48 and 49, such that the transverse interconnecting portions 40 and 45 are biased together. The securing element 3 comprises a first securing element, and a second securing element 50 identical to the first securing element 3 is provided at a second side of the furniture leg assembly 1 and rotationally supports the second leg 43. The same reference

numerals are used for the identical features of the first securing element 3 and the second securing element 50. The open-ended box section 35 is a first open-ended box section and a second open-ended box section 51 is provided on the other side of the table frame 36. The first securing element 3 is mounted in the first open-ended box section 35, and the second securing element 50 is mounted in the second open-ended box section 51. The transverse interconnecting portion 40 of the U-shaped two leg component 41 passes through the first box section 35 and the first securing element 3 as described above, and also the second box section 51 and second securing element 50 in the same manner on the other side.

[0044] In use the user can move the legs 2 and 43 from the stored position to the support position by manually manipulating the U-shaped two leg component 41 and/or the U-shaped two support element component 44 at any point. Sufficient force must be applied to lift the interconnecting transverse portion 45 over the abutments 28. Once this is achieved the interconnecting transverse portion 45 rides over the top surfaces 11 until it snaps into the sockets 13, where it is maintained by the biasing force. If the interconnecting transverse portion 45 is lifted away from the top surfaces 11 towards the end of its rotational movement, it will come into contact with the guide surfaces 25, which will guide it into the sockets 13. The legs 2 and 43 are then in the supporting position as shown in Figure 5 and the table 4 can be used in the conventional manner.

[0045] In order to collapse the table 4 for storage, the user grips the interconnecting transverse portion 45 (or uses an appropriate tool), and applies sufficient force to withdraw it from the sockets 13. When this action is carried out the interconnecting transverse portion 45 is prevented from travelling further away from the points 7 than is made possible by the stop walls 14. This prevents any over extension of the U-shaped two support element component 44 in relation to the U-shaped two leg component 41, which could harm or weaken the parts which provide the biasing force. Once the interconnecting transverse portion 45 is free of the sockets 13 the first leg 2 and second leg 43 can be rotated back towards the stored position. As this occurs the interconnecting transverse portion 45 rides over the top surfaces 11 and over the abutments 28 until it reaches its locked position, and the U-shaped two leg component 41 is arranged with the first leg 2 and the second leg 43 in the stored position. The biasing force act to retain the interconnecting transverse portion 45 in the locked position behind the abutments 28, which prevents inadvertent rotation of the first leg 2 and second leg 43.

[0046] The second aspect of the present invention relates to an item of furniture comprising a furniture leg assembly as described above, and this is shown in Figure 5, which illustrates table 1 with furniture leg assemblies 1 like that described above at both ends.

[0047] The invention can be altered without departing

from the scope of claim 1. For example in one alternative embodiment of the first aspect of the present invention (not shown) the securing element is designed to be affixed to the underside of an item of furniture with screws.

5 In alternative embodiments of the second aspect of the present invention (not shown) the item of furniture is one or a stool, chair or a bench.

[0048] Therefore, the present invention provides a furniture leg assembly like that shown in GB2392204, but which addresses the issue of preventing the transverse portion of the support element being pulled too far from the leg by providing the stop wall. This addresses the main cause of damage being caused to these kinds of furniture leg assembly, which occurs when users pull the transverse portion from the socket.

Claims

- 20 1. A furniture leg assembly comprising a leg, a securing element for securing said leg assembly to an item of furniture with which it is used, and a support element disposed adjacent to said leg,
 - 25 in which said leg is rotationally attached to a first part of said securing element and is rotatable about a point from a stored position to a supporting position in which said leg extends at an angle to a longitudinal axis of said securing element,
 - 30 in which an outer end of said support element is attached to said leg such that a biasing force biases an inner end of said support element towards said leg,
 - 35 in which said support element comprises a transverse portion extending in a transverse direction from said inner end, which transverse portion is disposed adjacent to said first part when said leg is in the stored position, and moves over a top surface of said first part into a distal locking part of said securing element when said leg rotates from said stored position to said supporting position,
 - 40 in which said distal locking part comprises a socket for releasably retaining said transverse portion, said socket being spaced from said point so said biasing force biases said transverse portion into said socket, and in which said distal locking part comprises a stop wall opposite to said socket, which delimits a distance said transverse portion can travel out from said socket.
- 50 2. A furniture leg assembly as claimed in claim 1 in which said distal locking part comprises a connecting portion which connects an inner surface of said socket to said stop wall, in which at least a section of said connecting portion and/or said stop wall is curved.
- 55 3. A furniture leg assembly as claimed in claim 2 in which said transverse portion comprises a circular cross-section, and in which said inner surface is

curved to matingly engage said transverse portion.

- 4. A furniture leg assembly as claimed in claim 3 in which said top surface comprises an abutment for restricting free movement of said transverse portion when it is disposed adjacent to said first part when said leg is in the stored position. 5
- 5. A furniture leg assembly as claimed in claim 4 in which said biasing force biases said transverse portion into a locked position behind said abutment, and in which said biasing force also biases said transverse portion into direct engagement with said top surface when moving between said first part and said distal locking part. 10 15
- 6. A furniture leg assembly as claimed in claim 5 in which said top surface is convex.
- 7. A furniture leg assembly as claimed in claim 6 in which a socket end section of said top surface is curved to a higher degree than a first part end of said top surface. 20
- 8. A furniture leg assembly as claimed in claim 7 in which said leg comprises a transverse boss extending in a transverse direction from an inner end thereof, said transverse boss being parallel with said transverse portion, and in which said transverse boss is arranged in a transverse aperture provided in said first part in order to facilitate its rotational movement. 25 30
- 9. A furniture leg assembly as claimed in claim 8 in which said first part comprises an engagement portion for affixing it to an item of furniture with which it is used, said engagement portion comprising the male part of an engagement mechanism, and in which said transverse aperture is provided in said male part. 35 40
- 10. A furniture leg assembly as claimed in claim 9 in which centres of said transverse aperture and said socket are both located on said longitudinal axis. 45
- 11. A furniture leg assembly as claimed in claim 1 in which when said transverse portion is disposed in said socket said leg extends at an angle to said longitudinal axis which is substantially 90 degrees or greater. 50
- 12. A furniture leg assembly as claimed in claim 1 in which said leg is part of a U-shaped two leg component, in which said support element is part of a U-shaped two support element component which is substantially the same shape as the U-shaped two leg component and is disposed adjacent to the U shaped two-leg component, in which the U-shaped

two leg component and the U-shaped two support element component are fixed together at their outer ends, such that transverse interconnecting portions of the U-shaped two leg component and the U-shaped two support element component are biased together, in which said securing element comprises a first securing element provided at one side of said furniture leg assembly and said leg comprises a first leg of said U-shaped two leg component, and in which a second securing element identical to said first securing element is provided at a second side of said furniture leg assembly and rotationally supports a second leg of said U-shaped two leg component.

- 13. An item of furniture comprising a furniture leg assembly of any of claims 1 to 12, in which said securing element is secured to an underside of a platform of said item of furniture, such that said leg is disposed in a plane substantially parallel to said platform in the stored position, and such that said leg extends at an angle to said platform which is substantially 90 degrees or greater in the supporting position.
- 14. An item of furniture as claimed in claim 14, in which said item of furniture is a table, bench or seat.

Figure 1

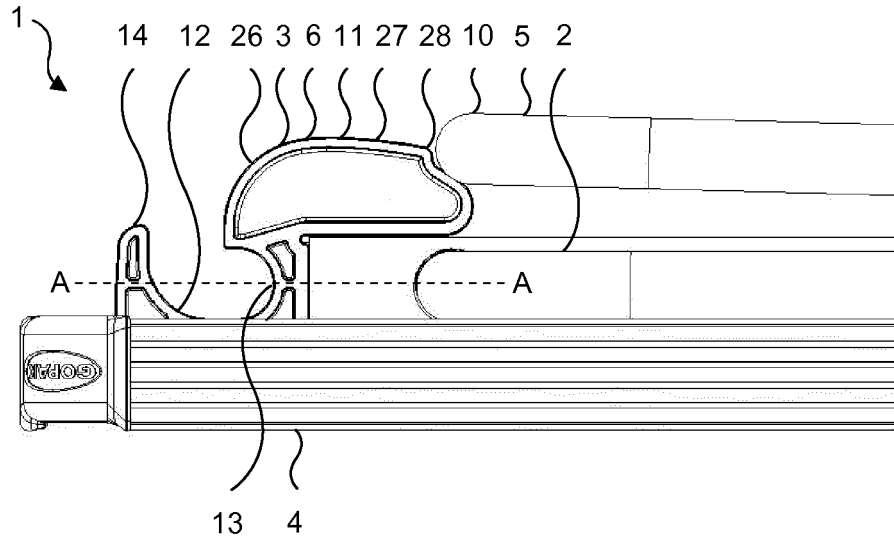

Figure 2

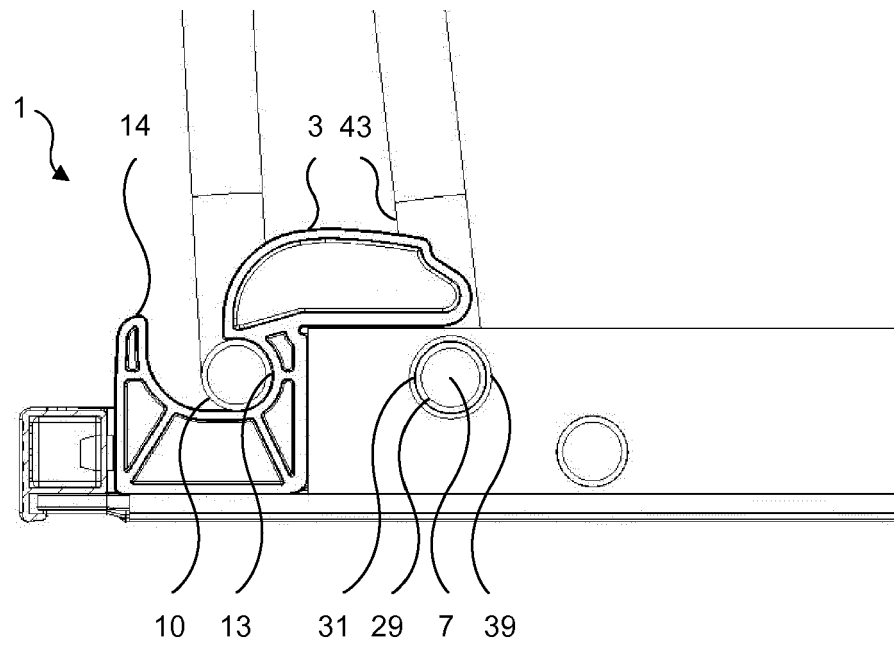

Figure 3

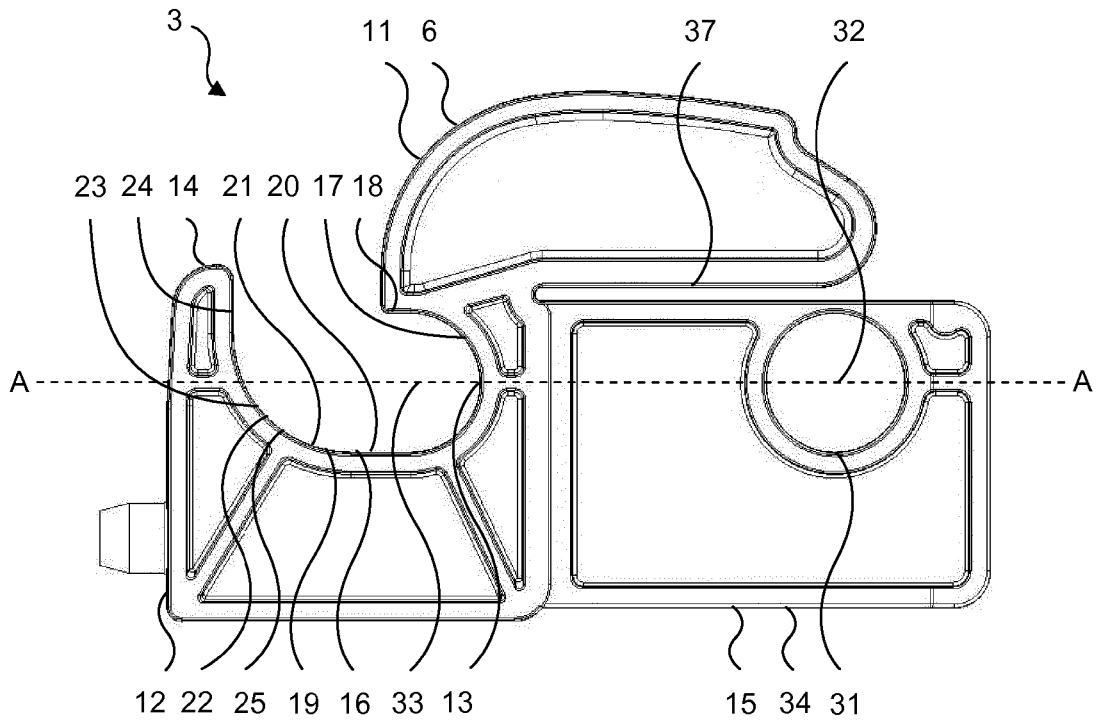

Figure 4

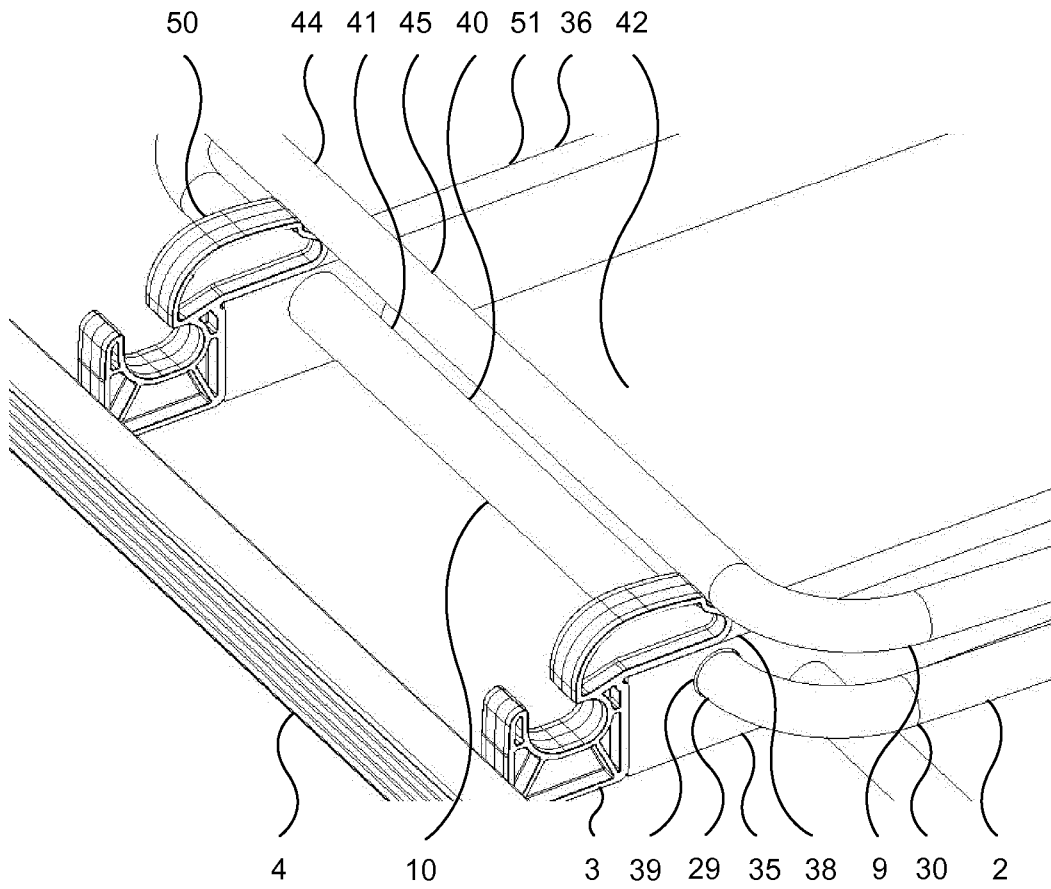
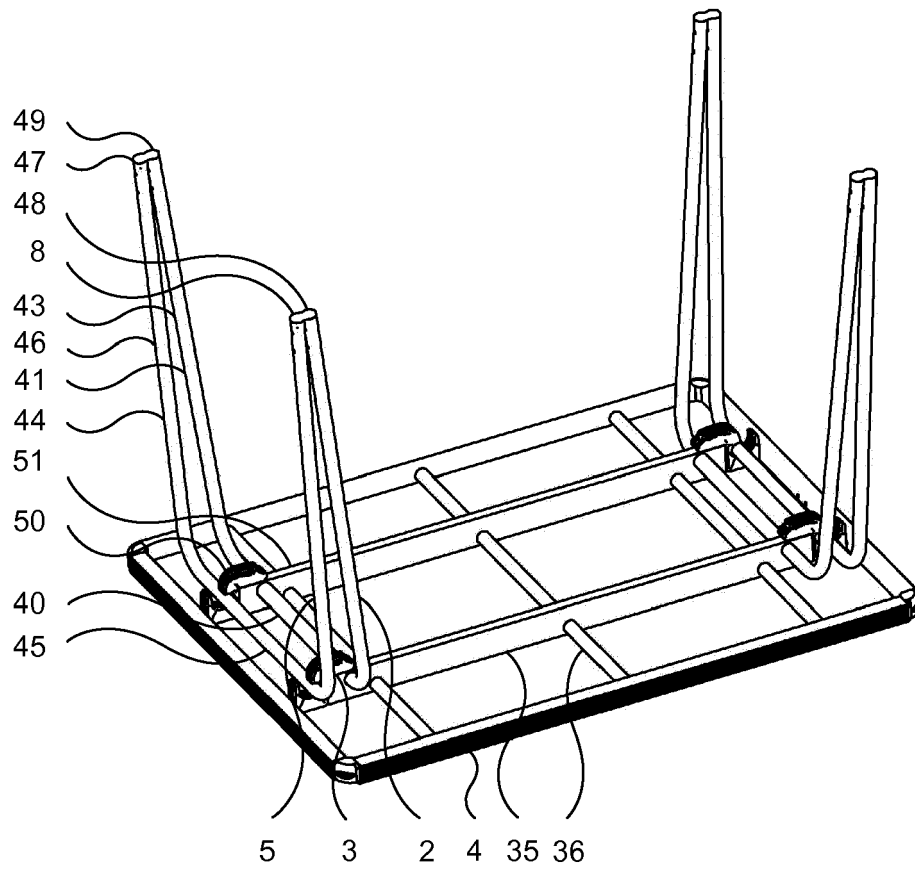

Figure 5





EUROPEAN SEARCH REPORT

Application Number
EP 18 18 9210

5

10

15

20

25

30

35

40

45

50

55

DOCUMENTS CONSIDERED TO BE RELEVANT			
Category	Citation of document with indication, where appropriate, of relevant passages	Relevant to claim	CLASSIFICATION OF THE APPLICATION (IPC)
A	GB 2 392 204 A (GOPAK LTD [GB]) 25 February 2004 (2004-02-25) * the whole document * -----	1-14	INV. A47B3/08 A47B3/091
A	US 5 367 962 A (TSENG CHUN-CHU [TW]) 29 November 1994 (1994-11-29) * abstract; figures * -----	1-14	
A	FR 2 415 985 A1 (CALVIGNAC ROLAND [FR]) 31 August 1979 (1979-08-31) * pages 1-6; figures * -----	1-14	
			TECHNICAL FIELDS SEARCHED (IPC)
			A47B
The present search report has been drawn up for all claims			
Place of search The Hague		Date of completion of the search 30 October 2018	Examiner Ottesen, Rune
CATEGORY OF CITED DOCUMENTS X : particularly relevant if taken alone Y : particularly relevant if combined with another document of the same category A : technological background O : non-written disclosure P : intermediate document		T : theory or principle underlying the invention E : earlier patent document, but published on, or after the filing date D : document cited in the application L : document cited for other reasons & : member of the same patent family, corresponding document	

EPO FORM 1503 03/02 (P04C01)

ANNEX TO THE EUROPEAN SEARCH REPORT
ON EUROPEAN PATENT APPLICATION NO.

EP 18 18 9210

5

This annex lists the patent family members relating to the patent documents cited in the above-mentioned European search report. The members are as contained in the European Patent Office EDP file on The European Patent Office is in no way liable for these particulars which are merely given for the purpose of information.

30-10-2018

10

Patent document cited in search report	Publication date	Patent family member(s)	Publication date
GB 2392204 A	25-02-2004	AT 368400 T	15-08-2007
		AU 2003251333 A1	16-02-2004
		DE 60315300 T2	17-04-2008
		DK 1524929 T3	26-11-2007
		EP 1524929 A1	27-04-2005
		ES 2291702 T3	01-03-2008
		GB 2392204 A	25-02-2004
		PT 1524929 E	15-10-2007
		US 2005217541 A1	06-10-2005
		WO 2004010823 A1	05-02-2004
		ZA 200409785 B	22-02-2006

US 5367962 A	29-11-1994	NONE	

FR 2415985 A1	31-08-1979	NONE	

15

20

25

30

35

40

45

50

55

EPO FORM P0459

For more details about this annex : see Official Journal of the European Patent Office, No. 12/82

REFERENCES CITED IN THE DESCRIPTION

This list of references cited by the applicant is for the reader's convenience only. It does not form part of the European patent document. Even though great care has been taken in compiling the references, errors or omissions cannot be excluded and the EPO disclaims all liability in this regard.

Patent documents cited in the description

- GB 2392204 A [0007] [0010] [0015] [0048]