

Description

FIELD

[0001] The present disclosure relates to a technical field of manufacturing of washing apparatus, particularly to a door-ring light-emitting assembly for a laundry treating device and a laundry treating device having the same.

BACKGROUND

[0002] At present, a processing state of a washing apparatus is usually displayed by a display screen of the washing apparatus. However, users usually leave the washing apparatus after starting it and conduct other activities. In conditions of a long distance or poor night vision, it is difficult for the users to view the processing state on the display screen of the washing apparatus. In the related art, a light-emitting door ring of some washing apparatuses can display the processing state of the washing apparatus, but it is only able to display two states of washing and drying, cannot feed back a real-time operation state of the apparatus effectively, and has poor display effect.

SUMMARY

[0003] The present disclosure aims to solve at least one of the above-mentioned technical problems to some extent.

[0004] Thus, the present disclosure provides a door-ring light-emitting assembly for a laundry treating device. The door-ring light-emitting assembly for the laundry treating device has a simple and compact structure and low manufacturing cost, is able to feed back a real-time operation state of an apparatus timely, has light escaping effect, facilitates observation by the user and has good user experience.

[0005] The present disclosure further provides a laundry treating device having the above-mentioned door-ring light-emitting assembly.

[0006] The door-ring light-emitting assembly for the laundry treating device according to embodiments of a first aspect of the present disclosure includes a main trim, an auxiliary trim, and a light source. The auxiliary trim is spaced apart from the main trim. The light source is arranged adjacent to the main trim. Light rays generated by the light source escape via a channel defined between the main trim and the auxiliary trim.

[0007] With the door-ring light-emitting assembly for the laundry treating device according to embodiments of the present disclosure, by arranging the main trim and the auxiliary trim to be spaced apart and the light source to be adjacent to the main trim, light rays escape via the channel between the main trim and the auxiliary trim, escaping effect is formed, which enlarges visual range of the light source, enhances display effect, facilitates observation by the user, and improves user experience.

The door-ring light-emitting assembly for the laundry treating device has a simple and compact structure and low manufacturing cost, and has the light escaping effect and better user experience.

5 [0008] In addition, the light-emitting assembly for the laundry treating device according to embodiments of the present disclosure can further have the following additional technical feature.

10 [0009] According to some embodiments of the present disclosure, the main trim has a main reflection surface able to reflect light; the auxiliary trim has an auxiliary reflection surface able to reflect light, and the light rays generated by the light source escape via at least one of the main reflection surface and the auxiliary reflection surface.

15 [0010] According to some embodiments of the present disclosure, the light rays generated by the light source escape via the auxiliary reflection surface of the auxiliary trim at first and the main reflection surface of the main trim then.

20 [0011] According to some embodiments of the present disclosure, the main trim, the auxiliary trim and the light source are configured to be annular separately.

25 [0012] According to some embodiments of the present disclosure, a section of the main trim is configured to have a first substantially L shape, and the main trim includes a first straight section and a first inclined section.

30 The first straight section extends along an axial direction of the main trim, and the first inclined section is connected to an end of the first straight section and extends outwards along a radial direction of the main trim and inclinedly towards a side of the axial direction of the main trim, an outer surface of the first inclined section facing the side is configured to be the main reflection surface.

35 The section of the auxiliary trim is configured to have a second substantially L shape, and the auxiliary trim includes a second straight section and a second inclined section. The second straight section extends along an axial direction of the auxiliary trim and is arranged coaxially with the first straight section. The second inclined section is connected to an end of the first straight section and extends outwards along a radial direction of the auxiliary trim and inclinedly towards the side of the axial direction of the auxiliary trim. An inner surface of the second inclined section facing away from the side is configured to be the auxiliary reflection surface.

40 [0013] According to some embodiments of the present disclosure, the light source is arranged between the first straight section and the second straight section.

45 [0014] According to some embodiments of the present disclosure, an inclined angle of the second inclined section with respect to the second straight section is greater than an inclined angle of the first inclined section with respect to the first straight section.

50 [0015] According to some embodiments of the present disclosure, an outwards-extending length of the second inclined section is less than an outwards-extending length of the first inclined section.

[0016] According to some embodiments of the present disclosure, the main reflection surface and the auxiliary reflection surface are configured to be an arc surface protruding towards the side separately.

[0017] According to some embodiments of the present disclosure, the first straight section and the first inclined section are molded integrally, and the second straight section and the second inclined section are molded integrally.

[0018] According to some embodiments of the present disclosure, the light-emitting assembly for the laundry treating device further includes a light uniformizing sheet, and the light uniformizing sheet is arranged between the light source and the auxiliary trim.

[0019] According to some embodiments of the present disclosure, the auxiliary reflection surface is configured to be a white surface.

[0020] According to some embodiments of the present disclosure, the light source is configured by a plurality of LED lights arranged continuously.

[0021] The laundry treating device according to embodiments of the second aspect of the present disclosure includes a machine body, a door body, and a door-ring light-emitting assembly for a laundry treating device according to the above-mentioned embodiments. The door body can be movably disposed to the machine body, and the light-emitting assembly is arranged to the door body.

[0022] With the laundry treating device according to embodiments of the present disclosure, by arranging the door-ring light-emitting assembly of the above-mentioned embodiments of the present disclosure to the door body, blooming effect of gradual changing and gradual weakening is formed by means of the light-emitting assembly, hence enlarging visual range of the light source, enhancing display effect, facilitating observation by the user, and improving user experience. The laundry treating device has a simple and compact structure and low manufacturing cost, and is able to feed back the real-time state timely and improve user experience.

[0023] Additional aspects and advantages of embodiments of present disclosure will be given in part in the following descriptions, become apparent in part from the following descriptions, or be learned from the practice of the embodiments of the present disclosure.

BRIEF DESCRIPTION OF THE DRAWINGS

[0024] These and other aspects and advantages of embodiments of the present disclosure will become apparent and more readily appreciated from the following descriptions made with reference to the drawings, in which:

Fig. 1 is a schematic view of a door-ring light-emitting assembly for a laundry treating device in operation according to embodiments of the present disclosure. Fig. 2 is an exploded view of a door body of a laundry treating device according to embodiments of the

present disclosure.

Fig. 3 is a sectional view of a door body of a laundry treating device according to embodiments of the present disclosure.

5 Fig. 4 is an enlarged view of portion "A" illustrated in Fig. 3.

Fig. 5 is an assembled view of a door body of a laundry treating device according to embodiments of the present disclosure.

10

Reference numerals:

[0025]

15 200: door body;
100: door-ring light-emitting assembly for laundry treating device;
10: light source;
20: main trim; 21: first inclined section; 22: first straight section;
20 30: auxiliary trim; 31: second inclined section; 32: second straight section;
50: light uniformizing sheet;
40: anti-scald cover;
25 60: connecting member;
70: door back ring;
80: glass bowl;
90: door hinge

30 DETAILED DESCRIPTION

[0026] The embodiments of the present disclosure are described in detail below, and the examples of the embodiments are illustrated in the drawings, in which the same or similar reference numerals are configured to refer to the same or similar elements or elements having the same or similar functions. The embodiments described below with reference to the drawings are illustrative, intended to explain the present disclosure, and cannot be construed to limit the present disclosure.

35 **[0027]** A door-ring light-emitting assembly 100 for a laundry treating device according to embodiments of the first aspect of the present disclosure is described specifically in conjunction with Figs. 1 to 5.

40 **[0028]** The door-ring light-emitting assembly 100 for the laundry treating device according to embodiments of the present disclosure includes a main trim 20, an auxiliary trim 30 and a light source 10.

[0029] Specifically, the auxiliary trim 30 and the main trim 20 are arranged spaced apart from each other, the light source 10 is arranged adjacent to the main trim 20, and light rays generated by the light source 10 escape via a channel defined between the main trim 20 and the auxiliary trim 30.

45 **[0030]** In other words, the door-ring light-emitting assembly 100 for the laundry treating device mainly includes the main trim 20, the auxiliary trim 30 and the light source 10. A section of the main trim 20 is configured to

have a first substantially L shape and a front face (i.e. a front end face of the main trim 20 illustrated in Fig. 1) of the main trim 20 forms into a curved face of a certain radian. A section of the auxiliary trim 30 is configured to have a second substantially L shape, and a back face of the auxiliary trim 30 forms into a curved face of a certain radian. The auxiliary trim 30 and the main trim 20 are arranged spaced apart in an axial direction (a front-and-rear direction in Fig. 1). The channel is defined between the back face of the auxiliary trim 30 and the front face of the main trim 20, and an extension line of a tangent line of the back face of the auxiliary trim 30 and an extension line of a tangent line of the front face of the main trim 20 intersect to form an included angle of a certain angle. The light source 10 is arranged between the auxiliary trim 30 and the main trim 20 along a left-and-right direction and adjacent to the main trim 20, and light rays generated by the light source 10 escape via the channel between an auxiliary reflection surface and a main reflection surface.

[0031] Thus, with the door-ring light-emitting assembly 100 for the laundry treating device according to embodiments of the present disclosure, by arranging the main trim 20 and the auxiliary trim 30 to be spaced apart, the channel is defined between the main trim 20 and the auxiliary trim 30; meanwhile, the light source 10 is arranged adjacent to the main trim 20, so that light rays escape via the channel between the main trim 20 and the auxiliary trim 30, escaping effect is formed, which enlarges visual range for the light source, enhances display effect, facilitates observation by the user, and improves user experience. The door-ring light-emitting assembly 100 for the laundry treating device has a simple and compact structure, low manufacturing cost, and has the light escaping effect and better user experience.

[0032] In some specific embodiments of the present disclosure, the main trim 20 has the main reflection surface which can reflect light, the auxiliary trim 30 has the auxiliary reflection surface which can reflect light, and light rays generated by the light source 10 escape via at least one of the main reflection surface and the auxiliary reflection surface.

[0033] With reference to Fig. 2 and Fig. 4, the section of the main trim 20 is configured to have the first substantially L shape, and the front face (i.e. the front end face of the main trim 20 illustrated in Fig. 1) of the main trim 20 forms into the curved face (i.e. the main reflection surface) of a certain radian. The curved face of certain radian of the main trim 20 can reflect the light rays entering the curved face by being reflected by the back face (a rear end face of the auxiliary trim 20 illustrated in Fig. 1) of the auxiliary trim 30, and can also directly reflect the light rays which escape from the channel, so that the light rays can be distributed gradually along the curved face of certain radian of the main trim 20, the further the distance, the weaker the intensity of the light rays, so that blooming effect of gradual changing and gradual disappearing is exhibited.

[0034] Further, the section of the auxiliary trim 30 is configured to have the second substantially L shape, and the back face of the auxiliary trim 30 forms into the curved face (i.e. the auxiliary reflection surface) of certain radian.

The auxiliary reflection surface of the auxiliary trim 30 and the main reflection surface of the main trim 20 are arranged spaced apart in the axial direction (the front-and-rear direction in Fig. 1). The extension line of the tangent line of the auxiliary reflection surface and the extension line of the tangent line of the main reflection surface intersect to form the included angle of certain angle. The light source 10 is arranged between the auxiliary trim 30 and the main trim 20 along the left-and-right direction, and light rays generated by the light source 10 escape via the included angle between the auxiliary reflection surface and the main reflection surface, and are irradiated upon the main reflection surface of the main trim 20 after being reflected by the auxiliary reflection surface.

[0035] Thus, the transmitted light rays by the light source 10 not only can be reflected to the main reflection surface of the main trim 20 by means of the auxiliary reflection surface of the auxiliary trim 30, but also can escape from the main reflection surface of the main trim 20, so that the light rays can be distributed along the main reflection surface of the main trim 20, thus forming blooming effect of gradual changing and gradual disappearing along a radial direction of the main reflection surface, hence enlarging visual range, enhancing display effect, facilitating observation by the user, and improving user experience. The door-ring light-emitting assembly 100 for the laundry treating device has the simple and compact structure, low manufacturing cost, is able to feed back the real-time state timely, and has the light escaping effect and better user experience.

[0036] The light rays generated by the light source escape via the auxiliary reflection surface of the auxiliary trim 30 firstly and then the main reflection surface of the main trim 20.

[0037] With reference to Fig. 1, the light source 10 is arranged between the auxiliary trim 30 and the main trim 20 along the left-and-right direction, the light rays generated by the light source 10 can escape through the channel between the auxiliary reflection surface and the main reflection surface, and are irradiated upon the main reflection surface of the main trim 20 after being reflected by the auxiliary reflection surface, and then be reflected by the main reflection surface of the main trim 20 and escape from the main reflection surface of the main trim 20.

[0038] In some specific embodiments of the present disclosure, the main trim 20, the auxiliary trim 30 and the light source 10 are respectively configured to be annular. Specifically, as illustrated in Figs. 2 to 4, the auxiliary trim 30, the light source 10 and the main trim 20 are respectively configured to be annular and arranged coaxially, and light rays of the annular light source 10 can be transmitted out through an included angle between the auxil-

ary trim 30 and the main trim 20, so that the light rays can be distributed along a circumferential direction after being reflected from the auxiliary reflection surface to the main reflection surface of the main trim 20, which further improves the uniformity of light rays and increases the visual range, enhancing the display effect.

[0039] The section of the main trim 20 is configured to have the first substantially L shape and includes a first straight section 22 and a first inclined section 21. The first straight section 22 extends along an axial direction of the main trim 20, and the first inclined section 21 is connected to an end of the first straight section 22 and extends outwards along a radial direction of the main trim 20 and inclinedly towards a side of the axial direction of the main trim 20, and an outer surface of the first inclined section 21 facing the side is configured to be the main reflection surface. The section of the auxiliary trim 30 is configured to have the second substantially L shape, and the auxiliary trim 30 includes a second straight section 32 and a second inclined section 31. The second straight section 32 extends along an axial direction of the auxiliary trim 30 and is arranged coaxially with the first straight section 22. The second inclined section 31 is connected to an end of the second straight section 32 and extends outwards along a radial direction of the auxiliary trim and inclinedly towards the side of the axial direction of the auxiliary trim 30. An inner surface of the second inclined section 31 facing away from the side is configured to be the auxiliary reflection surface.

[0040] Specifically, as illustrated in Figs. 1 to 4, the main trim 20 mainly includes the first straight section 22 and the first inclined section 21, the section of the main trim 20 is configured to have the first substantially L shape, the first straight section 22 extends along the axial direction (the front-and-rear direction as illustrated in Fig. 1) of the main trim 20, and an end of the first inclined section 21 is connected to a front end of the first straight section 22, and the first inclined section 21 extends outwards along the radial direction of the main reflection surface of the main trim 20 and inclinedly towards a side of an axial direction of the first inclined section 21. The outer surface of the first inclined section 21 facing the side in the axial direction is configured to be the main reflection surface, for example, as illustrated in Fig. 1, in the present embodiment, the first inclined section 21 extends outwards along the radial direction of the main reflection surface of the main trim 20 and inclinedly forwards with respect to the axial direction (the front-and-rear direction in Fig. 1) of the first inclined section 21, and the front face (the front end face as illustrated in Fig. 1) of the first inclined section 21 is configured to be the main reflection surface.

[0041] Further, the auxiliary trim 30 mainly includes the second straight section 32 and the second inclined section 31. The section of the auxiliary trim 30 is configured to have the second substantially L shape, and the second straight section 32 extends along the axial direction (i.e. the front-and-rear direction as illustrated in Fig. 1) of the

auxiliary trim 30 and is arranged coaxially with the first straight section 22. An end of the second inclined section 31 is connected to a front end of the second straight section 32 and the second inclined section 31 extends outwards along the radial direction of the auxiliary reflection surface of the auxiliary trim 30 and inclinedly towards the side of the axial direction of the second inclined section 31. An outer surface of the second inclined section 31 facing away from the side in the axial direction is configured to be the auxiliary reflection surface, for example, as illustrated in Fig. 1, in the present embodiment, the second inclined section 31 extends outwards along the radial direction of the auxiliary reflection surface of the auxiliary trim 30 and inclinedly forwards with respect to the axial direction (the front-and-rear direction in Fig. 1) of the second inclined section 31, and the back face (the rear end surface as illustrated in Fig. 1) of the second inclined section 31 is configured to be the auxiliary reflection surface.

[0042] It is to be illustrated that "inner" can be construed as a side pointing towards a circle center in the radial direction of the main trim 20, and the opposite direction is defined as "outer".

[0043] The light source 10 is arranged between the first straight section 22 and the second straight section 32.

[0044] Referring to Fig. 1, the light source 10 is arranged between the first straight section 22 and the second straight section 32 and adjacent to the first straight section 22, so that the light rays of the light source 10 can escape from the included angle between the main trim 20 and the auxiliary trim 30. After the reflection of the auxiliary reflection surface and the main reflection surface, the blooming effect of gradual changing and gradual weakening along the radial direction of the main reflection surface of the main trim 20 is formed.

[0045] In some specific embodiments of the present disclosure, an inclined angle of the second inclined section 31 with respect to the second straight section 32 is greater than an inclined angle of the first inclined section 21 with respect to the first straight section 22.

[0046] Specifically, as illustrated in Fig. 1, the main trim 20 and the auxiliary trim 30 are arranged coaxially, the inclined angle of the first inclined section 21 with respect to the first straight section 22 is less than the inclined angle of the second inclined section 31 with respect to the second straight section 32, so that it is ensured that the included angle of certain angle is formed between the extension line of the tangent line of the first inclined section 21 and the extension line of the tangent line of the second inclined section 31, thus increasing a range where the light rays are reflected to the main reflection surface of the first inclined section 21 through the auxiliary reflection surface at the second inclined section 31, and enhancing the blooming effect.

[0047] An outwards-extending length of the second inclined section 31 is less than an outwards-extending length of the first inclined section 21. Thus, not only it is

ensured that the light rays can be reflected to the main reflection surface of the first inclined section 21 through the auxiliary reflection surface of the second inclined section 31, but also it is able to prevent the second inclined section 31 from blocking the light rays reflected by the main reflection surface of the first inclined section 21 to reduce the visual range of user.

[0048] The main reflection surface and the auxiliary reflection surface are configured to be an arc surface protruding towards the side separately.

[0049] Referring to Figs. 1 and 4, each of the main reflection surface and the auxiliary reflection surface protrudes forwards along the axial direction (the front-and-rear direction as illustrated in Fig. 1) to form the arc surface, so that not only the range for light rays reflection can be increased, but also the light rays reflected on the main reflection surface can be distributed along the arc curved face of the main reflection surface and get weaken gradually along the radial direction of the main reflection surface, so that the visual range and the display effect can be increased.

[0050] Optionally, the first straight section 22 and the first inclined section 21 are molded integrally, and the second straight section 32 and the second inclined section 31 are molded integrally. The integrally molded structure can not only ensure the connection reliability of various components, enhance structural strength of the main trim 20 and the auxiliary trim 30, but also simplify the manufacturing procedure due to convenient molding, so that the production efficiency of the door-ring light-emitting assembly 100 is increased. Certainly, the first straight section 22 and the first inclined section 21, the second straight section 32 and the second inclined section 31 can also be assemblies in fixed connection, which is not limited in the present disclosure.

[0051] In addition, in some embodiments of the present disclosure, the door-ring light-emitting assembly 100 for the laundry treating device further includes a light uniformizing sheet 50, and the light uniformizing sheet 50 is arranged between the light source 10 and the auxiliary trim 30.

[0052] Referring to Fig. 4, the light uniformizing sheet 50 is arranged adjacent to the light source 10 and between the light source 10 and the auxiliary trim 30, so that with the light transmission and light diffusion property of the light uniformizing sheet 50, the uniformity of light rays of the light source 10 is improved, the formation of dark area is reduced, and the display effect of the door-ring light-emitting assembly 100 is enhanced.

[0053] The auxiliary reflection surface is configured to be a white surface. Thus, with the light reflection characteristic of white, the light rays of the light source 10 can be reflected to the main reflection surface by the auxiliary reflection surface more fully, so that the reflection effect of the auxiliary reflection surface is enhanced, and hence the display effect and visual range of light rays on the main reflection surface is increased.

[0054] Optionally, the light source 10 is configured by

a plurality of LED lights arranged continuously. Thus, by providing the LED lights, not only brightening effect indicating different processing states of the laundry treating device is achieved and the real-time state of the laundry treating device is fed back to the user timely, but also the manufacturing cost of the door-ring light-emitting assembly 100 can be reduced effectively, and the service life can be increased. Certainly, annular lamp tube or other lamps can also be adopted as the light source 10, which is not limited in the present disclosure.

[0055] The laundry treating device (not illustrated) according to embodiments of the second aspect of the present disclosure is described specifically with reference to Figs. 1 to 5.

[0056] The laundry treating device according to embodiments of the present disclosure includes a machine body (not illustrated), a door body 200 and the door-ring light-emitting assembly 100 for the laundry treating device according to the above-mentioned embodiments. The door body 200 can be movably disposed to the machine body, and the door-ring light-emitting assembly 100 is disposed to the door body.

[0057] In other words, the laundry treating device mainly includes the machine body, the door body 200 and the door-ring light-emitting assembly 100 for the laundry treating device according to the above-mentioned embodiments. The door body 200 is movably disposed to the machine body by means of a door hinge 90. The door body 200 mainly includes the door-ring light-emitting assembly 100, an anti-scald cover 40, a connecting member 60, a door back ring 70 and a glass bowl 80. The door-ring light-emitting assembly 100, the anti-scald cover 40, the connecting member 60, the door back ring 70, and the glass bowl 80 are disposed coaxially. The door-ring light-emitting assembly 100 is fixed to the glass bowl 80 by means of the connecting member 60, and the door back ring 70 is disposed at inner side of the door body 200 and fitted with the connecting member 60 and the glass bowl 80. The anti-scald cover 40 is arranged at an outer circumference side of the main trim 20 of the door-ring light-emitting assembly 100, so that damage to the user due to temperature rise of the main trim 20 of the door-ring light-emitting assembly 100 resulted by light rays illumination is prevented.

[0058] As the door-ring light-emitting assembly 100 for the laundry treating device according to embodiments of the present disclosure has the above-mentioned technical effect, the laundry treating device according to embodiments of the present disclosure also has the above-described technical effect, that is, by arranging the light source 10 between the auxiliary trim 30 and the main trim 20, the light rays transmitted by the light source 10 is reflected to the main reflection surface of the main trim 20 by means of the auxiliary reflection surface of the auxiliary trim 30, so that the light rays are distributed along the main reflection surface of the main trim 20, and the blooming effect of gradual changing and gradual weakening along the radial direction of the main reflection sur-

face, which further enlarges visual range, enhances display effect, facilitates observation by the user, and improves user experience. The laundry treating device has a simple and compact structure, low manufacturing cost, is able to feed back the real-time state, and has the light escaping effect and better user experience.

[0059] Other configurations of the door-ring light-emitting assembly 100 for the laundry treating device and the laundry treating device having the door-ring light-emitting assembly 100 according to embodiments of the present disclosure are known to those ordinarily skilled in the art, which will not be described in detail here.

[0060] In the specification, it is to be understood that terms such as "central," "length," "width," "thickness," "front," "rear," "left," "right," "vertical," "horizontal," "inner," and "outer" should be construed to refer to the orientation as then described or as shown in the drawings under discussion. These relative terms are for convenience of description and do not require that the present disclosure be constructed or operated in a particular orientation, and cannot be construed to limit the present disclosure.

[0061] In the present disclosure, unless specified or limited otherwise, the terms "mounted," "connected," "coupled," "fixed" and the like are used broadly, and may be, for example, fixed connections, detachable connections, or integral connections; may also be mechanical or electrical connections; may also be direct connections or indirect connections via intervening structures; may also be inner communications of two elements, which can be understood by those skilled in the art according to specific situations.

[0062] Reference throughout this specification to "an embodiment," "some embodiments," "an example," "a specific example," or "some examples," means that a particular feature, structure, material, or characteristic described in connection with the embodiment or example is included in at least one embodiment or example of the present disclosure. Thus, the appearances of the phrases in various places throughout this specification are not necessarily referring to the same embodiment or example of the present disclosure. Furthermore, the particular features, structures, materials, or characteristics may be combined in any suitable manner in one or more embodiments or examples.

[0063] Although explanatory embodiments have been shown and described, it would be appreciated by those skilled in the art that the above embodiments cannot be construed to limit the present disclosure, and changes, alternatives, variation, and modifications can be made in the embodiments without departing from spirit, principles and scope of the present disclosure.

Claims

1. A door-ring light-emitting assembly for a laundry treating device, comprising:

a main trim;
 an auxiliary trim spaced apart from the main trim;
 and
 a light source arranged adjacent to the main trim, wherein light rays generated by the light source escape via a channel defined between the main trim and the auxiliary trim.

2. The door-ring light-emitting assembly for the laundry treating device according to claim 1, wherein the main trim has a main reflection surface capable of reflecting light, the auxiliary trim has an auxiliary reflection surface capable of reflecting light, and the light rays generated by the light source escape via at least one of the main reflection surface and the auxiliary reflection surface.

3. The door-ring light-emitting assembly for the laundry treating device according to claim 2, wherein the light rays generated by the light source escape via the auxiliary reflection surface of the auxiliary trim first and then the main reflection surface of the main trim.

4. The door-ring light-emitting assembly for the laundry treating device according to claim 3, wherein the main trim, the auxiliary trim and the light source are configured to be annular separately.

5. The door-ring light-emitting assembly for the laundry treating device according to claim 3 or 4, wherein a section of the main trim is configured to have a first substantially L shape, the main trim comprises a first straight section and a first inclined section, the first straight section extends along an axial direction of the main trim, the first inclined section is connected to an end of the first straight section and extends outwards along a radial direction of the main trim and inclinedly towards a side of the axial direction of the main trim, an outer surface of the first inclined section facing the side is configured to be the main reflection surface;

a section of the auxiliary trim is configured to have a second substantially L shape, the auxiliary trim comprises a second straight section and a second inclined section, the second straight section extends along an axial direction of the auxiliary trim and is arranged coaxially with the first straight section, the second inclined section is connected to an end of the second straight section and extends outwards along a radial direction of the auxiliary trim and inclinedly towards the side of the axial direction of the auxiliary trim, and an inner surface of the second inclined section facing away from the side is configured to be the auxiliary reflection surface.

6. The door-ring light-emitting assembly for the laundry treating device according to claim 5, wherein the light source is arranged between the first straight section

and the second straight section.

7. The door-ring light-emitting assembly for the laundry treating device according to claim 5, wherein an inclined angle of the second inclined section with respect to the second straight section is greater than an inclined angle of the first inclined section with respect to the first straight section. 5
8. The door-ring light-emitting assembly for the laundry treating device according to claim 5, wherein an outwards-extending length of the second inclined section is less than an outwards-extending length of the first inclined section. 10
15
9. The door-ring light-emitting assembly for the laundry treating device according to claim 5, wherein the main reflection surface and the auxiliary reflection surface are configured to be an arc surface protruding towards the side separately. 20
10. The door-ring light-emitting assembly for the laundry treating device according to claim 5, wherein the first straight section and the first inclined section are molded integrally, and the second straight section and the second inclined section are molded integrally. 25
11. The door-ring light-emitting assembly for the laundry treating device according to claim 6, further comprising a light uniformizing sheet arranged between the light source and the auxiliary trim. 30
12. The door-ring light-emitting assembly for the laundry treating device according to any one of claims 1 to 11, wherein the auxiliary reflection surface is configured to be a white surface. 35
13. The door-ring light-emitting assembly for the laundry treating device according to any one of claims 1 to 12, wherein the light source is configured by a plurality of LED lights arranged continuously. 40
14. A laundry treating device, comprising: 45
- a machine body;
 - a door body movably disposed to the machine body; and
 - a door-ring light-emitting assembly for a laundry treating device according to any one of claims 1 to 13, wherein the light-emitting assembly is disposed to the door body. 50

55

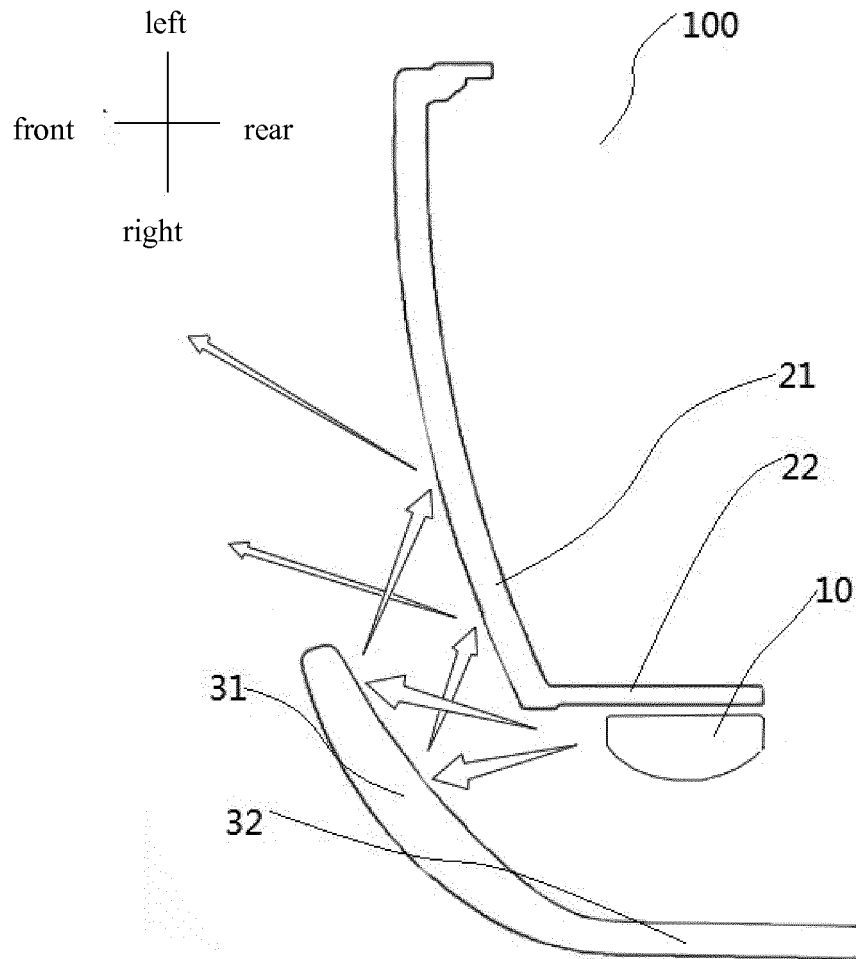

Fig. 1

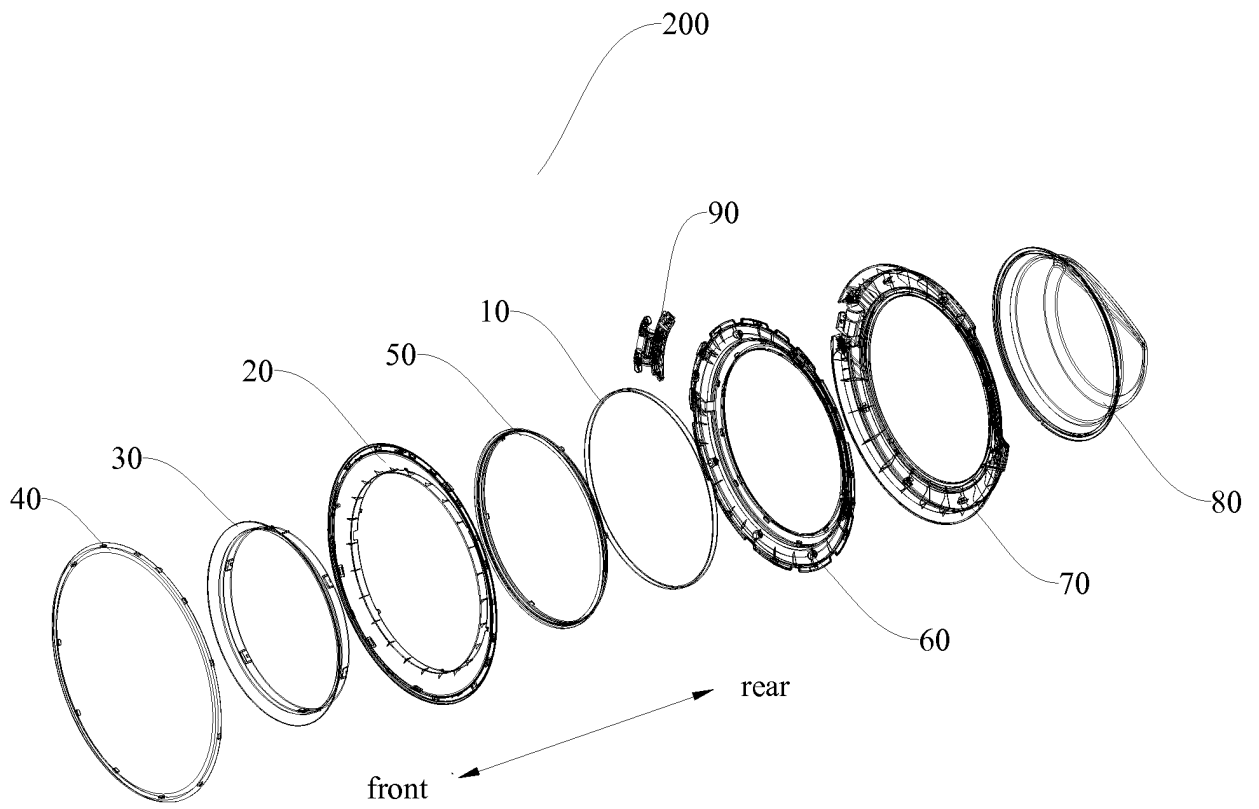

Fig. 2

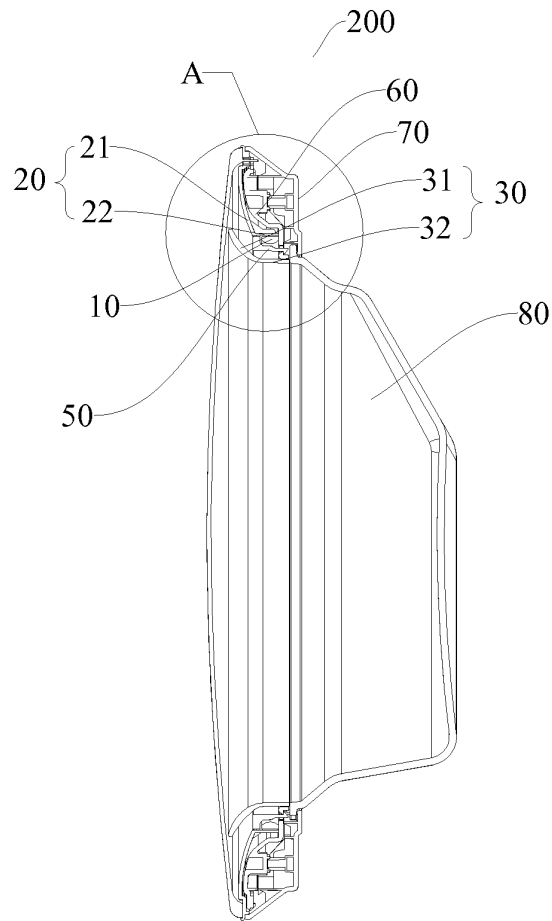

Fig. 3

A

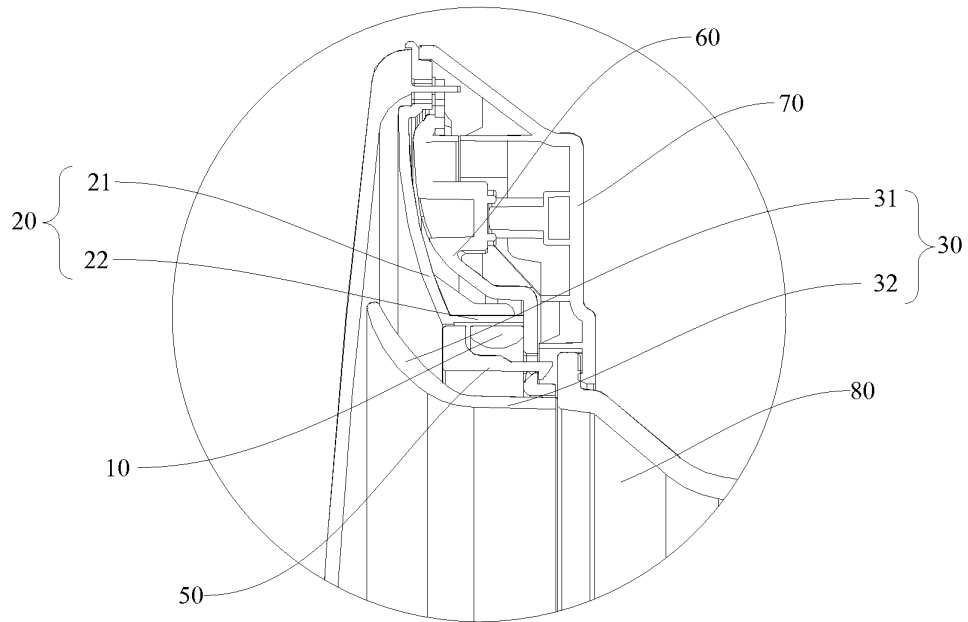

Fig. 4

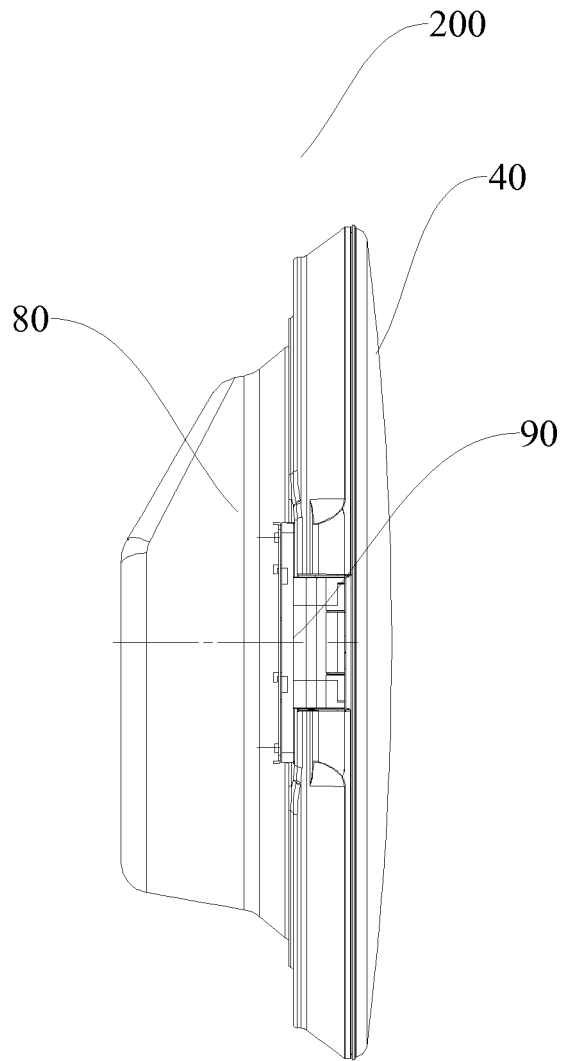

Fig. 5

INTERNATIONAL SEARCH REPORT

International application No.
PCT/CN2016/100913

5	A. CLASSIFICATION OF SUBJECT MATTER		
	D06F 39/14 (2006.01) i		
	According to International Patent Classification (IPC) or to both national classification and IPC		
10	B. FIELDS SEARCHED		
	Minimum documentation searched (classification system followed by classification symbols)		
	D06F 39/-		
15	Documentation searched other than minimum documentation to the extent that such documents are included in the fields searched		
	Electronic data base consulted during the international search (name of data base and, where practicable, search terms used)		
	WPI; EPODOC; CNPAT; China Journal Full-text Database: 门, 圈, 衣物, 衣服, 洗衣机, 灯, 光线, 反光, 发光, 反射, 通道, 溢出, door, ring, cloth+, wash+, laundry, lamp, light+, illuminat+, reflect+, passage, channel, overflow+		
20	C. DOCUMENTS CONSIDERED TO BE RELEVANT		
	Category*	Citation of document, with indication, where appropriate, of the relevant passages	
		Relevant to claim No.	
25	X	US 2008037275 A1 (MIELE & CIE. K.G.), 14 February 2008 (14.02.2008), description, paragraph [0022], and figure 3c	1, 13
	A	CN 104471140 A (BSH BOSCH UND SIEMENS HAUSGERAETE GMBH), 25 March 2015 (25.03.2015), entire document	1-14
	A	CN 205275986 U (ELEKTRA INDUSTRIAL CHINA CO., LTD.), 01 June 2016 (01.06.2016), entire document	1-14
30	A	CN 101532235 A (PANASONIC CORPORATION), 16 September 2009 (16.09.2009), entire document	1-14
	A	JP 2008136752 A (MATSUSHITA DENKI SANGYO K.K.), 19 June 2008 (19.06.2008), entire document	1-14
	A	KR 20140141099 A (SAMSUNG ELECTRONICS CO., LTD.), 10 December 2014 (10.12.2014), entire document	1-14
35	<input checked="" type="checkbox"/> Further documents are listed in the continuation of Box C. <input checked="" type="checkbox"/> See patent family annex.		
	* Special categories of cited documents:	“T” later document published after the international filing date or priority date and not in conflict with the application but cited to understand the principle or theory underlying the invention	
40	“A” document defining the general state of the art which is not considered to be of particular relevance	“X” document of particular relevance; the claimed invention cannot be considered novel or cannot be considered to involve an inventive step when the document is taken alone	
	“E” earlier application or patent but published on or after the international filing date	“Y” document of particular relevance; the claimed invention cannot be considered to involve an inventive step when the document is combined with one or more other such documents, such combination being obvious to a person skilled in the art	
45	“L” document which may throw doubts on priority claim(s) or which is cited to establish the publication date of another citation or other special reason (as specified)	“&” document member of the same patent family	
	“O” document referring to an oral disclosure, use, exhibition or other means		
	“P” document published prior to the international filing date but later than the priority date claimed		
50	Date of the actual completion of the international search 09 May 2017	Date of mailing of the international search report 19 May 2017	
55	Name and mailing address of the ISA State Intellectual Property Office of the P. R. China No. 6, Xitucheng Road, Jimenqiao Haidian District, Beijing 100088, China Facsimile No. (86-10) 62019451	Authorized officer JI, Chuanlong Telephone No. (86-10) 010-62413106	

Form PCT/ISA/210 (second sheet) (July 2009)

INTERNATIONAL SEARCH REPORT

International application No.
PCT/CN2016/100913

5
10
15
20
25
30
35
40
45
50
55

C (Continuation). DOCUMENTS CONSIDERED TO BE RELEVANT		
Category*	Citation of document, with indication, where appropriate, of the relevant passages	Relevant to claim No.
A	WO 0214593 A2 (ARCELIK A.S.), 21 February 2002 (21.02.2002), entire document	1-14

INTERNATIONAL SEARCH REPORT
 Information on patent family members

 International application No.
 PCT/CN2016/100913

Patent Documents referred in the Report	Publication Date	Patent Family	Publication Date
US 2008037275 A1	14 February 2008	EP 1735493 B1	11 August 2010
		ES 2348908 T3	16 December 2010
		WO 2005093149 A1	06 October 2005
		EP 1735493 A1	27 December 2006
		DE 502005010073 D1	23 September 2010
		DE 102004015078 A1	20 October 2005
CN 104471140 A	25 March 2015	DE 102012212550 A1	23 January 2014
		KR 20150033648 A	01 April 2015
		CN 104471140 B	09 November 2016
		WO 2014012784 A1	23 January 2014
		EP 2875177 B1	14 September 2016
		US 9429311 B2	30 August 2016
		US 2015176832 A1	25 June 2015
		RU 2015102063 A	10 September 2016
		EP 2875177 A1	27 May 2015
		IN 201403042 P2	04 December 2015
		RU 2605184 C2	20 December 2016
CN 205275986 U	01 June 2016	None	
CN 101532235 A	16 September 2009	EP 2103729 B1	20 March 2013
		SG 155828 A1	29 October 2009
		CN 201372375 Y	30 December 2009
		EP 2103729 A1	23 September 2009
		JP 2009213804 A	24 September 2009
		TW 200944634 A	01 November 2009
		MY 151690 A	30 June 2014
		RU 2401347 C1	10 October 2010
		CN 101532235 B	20 July 2011
		SG 155828 B	30 December 2011
		JP 4876876 B2	15 February 2012
JP 2008136752 A	19 June 2008	None	
KR 20140141099 A	10 December 2014	EP 1309749 B1	07 December 2005
WO 0214593 A2	21 February 2002	EP 1568816 A2	31 August 2005
		WO 0214593 A3	06 June 2002
		ES 2254486 T3	16 June 2006
		DE 60133845 D1	12 June 2008
		DE 60115664 T2	31 August 2006
		AU 8820701 A	25 February 2002
		EP 1568816 B1	30 April 2008
		EP 1309749 A2	14 May 2003
		DE 60115664 D1	12 January 2006