



(12) **EUROPEAN PATENT APPLICATION**

(43) Date of publication:  
**10.07.2019 Bulletin 2019/28**

(51) Int Cl.:  
**D01H 4/36 (2006.01)**

(21) Application number: **18214370.1**

(22) Date of filing: **20.12.2018**

(84) Designated Contracting States:  
**AL AT BE BG CH CY CZ DE DK EE ES FI FR GB GR HR HU IE IS IT LI LT LU LV MC MK MT NL NO PL PT RO RS SE SI SK SM TR**  
 Designated Extension States:  
**BA ME**  
 Designated Validation States:  
**KH MA MD TN**

(71) Applicant: **Maschinenfabrik Rieter AG**  
**8406 Winterthur (CH)**

(72) Inventors:  
 • **Storek, Jiri**  
**562 01 Usti nad Orlici (CZ)**  
 • **Rehak, Martin**  
**565 01 Chocen (CZ)**

(30) Priority: **04.01.2018 CZ 20180003**

(74) Representative: **Musil, Dobroslav**  
**Zabrdovicka 801/11**  
**615 00 Brno (CZ)**

(54) **A METHOD AND A DEVICE FOR REMOVING SMALL PARTICLES OF IMPURITIES FROM TEXTILE MACHINES**

(57) The invention relates to a method for removing impurities, particularly dust and/or very small portions of fibers contained in a sliver during the opening of fibers from the sliver in an opening device (2) of an open-end spinning machine, in which the sliver is fed by a feeding device to toothed surface (23) of an opening roller (22), by which the individual fibers of the sliver in an opening zone (26) are pulled out from the grip by the feeding device and are guided in the opening device along a primary removal zone (3) for removing small and very small impurities and then are guided along a secondary removal

zone (5) for removing the remaining impurities, **characterized in that** in the primary removal zone (3) the fibers are acted upon by the vacuum from a central channel (6) only behind the opening zone (26), whereupon in the secondary impurities removal zone (5) the fibers are acted upon by the centrifugal force and by the vacuum from the central channel (6).

The invention also relates to a device for performing this method in a spinning unit of an open-end spinning machine.

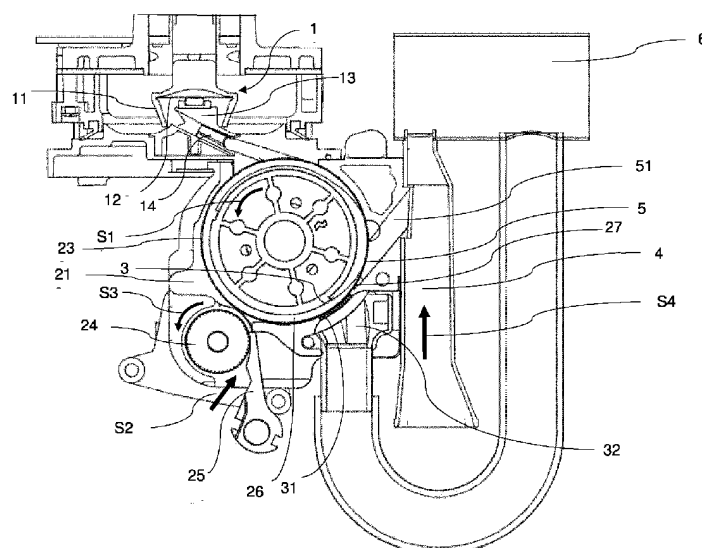

**Fig. 1**

## Description

### Technical field

**[0001]** A method for removing impurities, particularly dust and/or very small portions of fibers contained in a sliver during the opening of fibers from the sliver in an opening device of an open-end spinning machine, in which the sliver is fed by a feeding device to toothed surface of an opening roller, by which the individual fibers of the sliver in the opening zone are pulled out from the grip by the sliver feeding device and are guided in the opening device along a primary removal zone to remove small and very small impurities, and subsequently are guided along a secondary removal zone to remove the other impurities. The invention also relates to a device for removing impurities, particularly dust particles and/or very small portions of fibers from a sliver in a spinning unit of an open-end spinning machine comprising a sliver feeding device associated with an opening device of sliver with a rotating opening roller with toothed surface for opening the fibers from the supplied sliver in an opening zone, whereby the spinning unit further comprises primary impurities removal zone provided with a sieve and a secondary impurities removal zone, the two zones being associated with the toothed surface of the opening roller and connected to an air vacuum system for removing impurities.

### Background art

**[0002]** One of the problems associated with the production of textile goods is the removal of impurities introduced into the machine by the material being processed or arising from the processing of the material. The cleanliness of the machine and its devices is particularly important in the processing of fine materials, for example in the production of yarns. For removing the impurities, machines are usually equipped with a vacuum suction system, or a gravity system. Their purpose is above all to eliminate hard impurities which are contained in the fibrous material, and, in the case of open-end spinning machines, the principal purpose is to prevent the clogging of a collecting groove of a spinning rotor.

**[0003]** Well-known impurities removal systems are capable of removing hard and relatively heavy particles. On the other hand, small and fine dust particles or very short portions of fibers whose weight is very low cannot practically be removed by suction. This applies particularly to those areas where, for technological reasons, there is a high under-pressure close to the value of the vacuum of the suction systems for removing impurities.

**[0004]** Thus, for example, document DE102008037000A1 solves the cleaning of a collecting groove of the spinning rotor after interrupting the spinning process and after opening the spinning unit by spraying the interior of the spinning rotor cup with hot pressure steam.

**[0005]** According to DE102008026776A1, a device with an electrically driven rotary brush is clamped to the front of the unit after opening the spinning unit, whereupon the brush cleans the collecting groove and sucks the loose impurities.

**[0006]** In the case of US6321521B1, the spinning process is also interrupted and the lid of the spinning unit is uncovered, whereupon the mouth of a suction tube of an adjoining service robot is brought to the interior of a rotor cup, in the immediate vicinity of a collecting groove. The rotor is rotated by a friction plate, which is also part of the service robot, and accelerated to speeds in which the adhering impurities are affected by centrifugal force and then sucked off by the suction tube.

**[0007]** It is apparent that the devices described are complex and, what is more, they require interruption of the manufacturing process of the machine during the removal of the particles adhering to the inner parts of the spinning unit.

**[0008]** CZ304228B6 solves, among other things, the removal of the maximum possible amount of impurities from the spun fibrous material. For this purpose, between the point of feeding the sliver to the opening roller and the point of the fiber removal to the spinning rotor, there is a hole for the impurities removal which is connected to the surrounding atmosphere. On the one hand, this hole serves to remove the impurities from the sliver being opened, and on the other hand, through this hole the air needed for spinning is sucked in by a vacuum system. Obviously, sucking this air in does not hamper the removal of heavier hard particles, but it works against the removal of fine and light particles.

**[0009]** CZ262402B2 discloses a solution in which the primary impurities removal zone is arranged directly in the opening zone, i.e. immediately beyond the edge of an inlet for feeding fibers to an opening roller, i.e. in a zone where the rear ends of the fibers are still held by a grip in the nip line by a sliver feeding device. In the embodiment of Fig. 2, although the sieve is moved further from the edge of the inlet opening, on both lateral sides of the opening zone are arranged suction holes covered with sieves for sucking the impurities directly from the opening zone, these holes being connected through channels to a central channel. The disadvantage of this embodiment is the fact that in the opening zone the loosening of the sliver only starts and thus the release of impurities begins only then, and from such an imperfectly loosened sliver in which the rear ends of the fibers are still held by the feeding device, the fine particles of dust and very small portions of the fibers, i.e., the particles having a low weight, are not sufficiently released and subsequently sucked off, which means that such particles are not removed from the fibers with such efficiency as is expected in modern machines. Another drawback is that the discharging channel described herein serves at the same time as an air supply to the spinning rotor, which further worsens the efficiency of the removal of small and very small impurities.

[0010] The aim of the invention is to prevent clogging and subsequent solid depositing of small and light particles at places from which they cannot easily be removed and to propose a device for the early removal of such particles even without having to stop production process during the operation of the spinning machine.

### Principle of the invention

[0011] The aim of the invention is achieved by a method for removing impurities, particularly dust particles and/or very small portions of fibers, whose principle consists in that in a primary removal zone, the fibers and impurities are acted upon by the vacuum from the central channel only behind (downstream of) an opening zone, whereupon in the secondary removal zone the fibers and impurities are simultaneously acted upon by centrifugal force and the vacuum from the central channel. This is made possible primarily by placing the primary zone immediately downstream of the opening zone, where the small particles are most easily removed by the vacuum.

[0012] Preferably, the size of the impurities sucked off is limited by a sieve through which the particles are sucked off by the vacuum, the individual sieve holes having a cross-section area not exceeding 1 mm<sup>2</sup>.

[0013] The aim of the invention is also achieved by a device for removing impurities, particularly dust particles and/or very small portions of fibers from a sliver in a spinning unit, whose principle consists in that a primary removal zone is arranged downstream of an opening zone and upstream of a secondary removal zone, whereby the width of the primary removal zone corresponds to the working width of an opening roller and the primary and secondary removal zones are connected to a vacuum system for sucking off impurities.

### Description of drawings

[0014] An exemplary embodiment according to the invention is schematically represented in the drawing, wherein Fig. 1 is a view of the respective parts of a spinning unit in the direction of the axis of rotation of an opening roller of an opening device and perpendicularly to the axis of rotation of a spinning rotor, Fig. 2 is an oblique view into the inner space of the body of the opening device.

### Examples of embodiment

[0015] Fig. 1 schematically represents a structure of a well-known spinning unit of an open-end spinning machine, which comprises a spinning rotor 1 with a conical cup 11 and a collecting groove 12 near the cup 11 bottom and a canopy 13 entering the cup 11 of the spinning rotor 1 in the axis of rotation of the spinning rotor 1 with an unillustrated draw-off funnel of the spun-out yarn. A channel 14 supplying the rotor 1 with the fibers singled out by an opening device 2 opens into the cup 11 of the spinning

rotor 1 obliquely with respect to the collecting groove 12. In the body 21 of the opening device 2 is provided a well-known opening roller 22 with an unillustrated toothed surface 23, driven in the direction S1. The sliver (not shown) is fed in the direction S3 by means of a well-known feeding roller 24 driven in the direction S2, towards the circumference of the feeding roller 24 the sliver is pushed by a feeding table 25. The sliver is thus supplied to the toothed surface 23 of the opening roller 22, by which the sliver is singled out into individual fibers which are pulled out from the grip between the feeding roller 24 and the feeding table 25 to the opening zone 26 and further carried through the gap around the toothed surface 23 of the opening roller 22 to the channel 14 through which the individual fibers are fed to the rotor 1.

[0016] The system of removing impurities according to the invention is divided into two zones, consisting of two successively spaced holes around the circumference of the body 21 of the opening device 2. A primary removal zone 3 is arranged immediately downstream of the opening zone 26 and is formed by a hole 31, which is joined by a discharging channel 32 which opens into a central channel 6 of the removal of impurities. This means that in the primary removal zone 3 the impurities are acted upon by the vacuum from the central channel 6 in the radial direction towards the gap around the toothed surface 23 of the opening roller 22, by which the fibers singled out/being singled out are withdrawn together with the impurities, whereby the fibers are dispersed after the start of the opening process in the opening zone 26, and so the air sucked off from the gap around the surface 23 of the opening roller 22 in the primary removal zone 3 passes between them, carrying the small and light particles of impurities which have been released by the opening and which are further carried through the discharging channel 32 to the central channel 6. The width L1 of the primary removal zone 3 corresponds to the working width of the opening roller 22. The hole 31 in the primary removal zone 3 in the wall of the body 21 of the opening device 2 is covered by a sieve formed by a network of circular, square or other shaped through flow holes (not shown), whereby the cross-sectional area of each of these elementary openings does not exceed 1 mm<sup>2</sup>. The opening process in the opening zone 26 is highly effective. Therefore, in the primary removal zone 3 even small and very light impurity particles are reliably sucked off from the sliver. The force acting here upon small and light particles of impurities is practically determined only by the vacuum air in the hole 31, which, due to the loosening of the fibers in the opening zone 26, is sufficient to remove these particles from the sliver. Through the discharging channel 32 assigned to the primary removal zone 3 the air is sucked in only from the space of the opening roller through the opening zone 26. The length of the opening zone 26 is determined by the production technology.

[0017] The primary removal zone 3, 31 is terminated in the body 21 of the opening device 2 by an edge 27, which constitutes the beginning of the secondary removal

zone 5 formed by an open mouth of the discharging channel 51, adjoining in the tangential direction the gap between the toothed surface 23 of the opening roller 22 and the circumference of a cylindrical cavity of the body 21 of the opening device 2. Larger and heavier particles of impurities are withdrawn from the fibers by the discharging channel 51, whereby they are removed primarily by the centrifugal force acting on them during the movement of the fibers. The exhaust of these separated particles to the discharging channel 51 is ensured by the vacuum in this channel. The discharging channel 51 opens into a collection vacuum channel 4, which is in the direction S4 of the air flow connected to the central channel 6 and whose inlet opening is connected to the surrounding atmosphere. The particles are withdrawn together from both the removal zones 3 and 5 through the central channel 6.

**[0018]** The device according to the invention substantially reduces the amount of particularly small and light particles of impurities entering the interior space of the spinning unit which in the devices of the background art require difficult and time-consuming cleaning.

#### List of references

##### [0019]

1	spinning rotor	
11	cup of the spinning rotor	
12	collecting groove of the spinning rotor	
13	canopy of the draw-off funnel	
14	fiber feeding channel to the spinning rotor	
2	opening device	
21	body of the opening device	
22	opening roller	
23	toothed surface of the opening roller	
24	feeding roller	
25	feeding table	
26	opening zone	
27	edge of the end of the primary and the beginning of the secondary removal zone	40
3	primary removal zone (of impurity particles)	
31	outlet hole of the primary removal zone	
32	discharging channel (of the primary removal zone)	
4	collection vacuum channel	45
5	secondary removal zone (of impurity particles)	
51	discharging channel (of the secondary removal zone)	
6	central channel of impurities removal	
L1	width of the primary removal zone	50
S1	direction of rotation of the opening roller	
S2	direction of feeding sliver (to the opening roller)	
S3	direction of rotation of the feeding roller	
S4	direction of air flow in the collection vacuum channel	55

#### Claims

1. A method for removing impurities, particularly dust and/or very small portions of fibers contained in a sliver during the opening of fibers from the sliver in an opening device (2) of an open-end spinning machine, during which the sliver is fed by a feeding device to toothed surface (23) of an opening roller (22), by which the individual fibers from the sliver in an opening zone (26) are opened and pulled out from the nip of the feeding device and are guided downstream along a primary removal zone (3) for removing small and very small impurities and then are guided along a secondary removal zone (5) for removing the rest of the impurities, **characterized in that** in the primary removal zone (3) the fibers are acted upon by the vacuum from a central channel (6) only behind the opening zone (26) whereupon the fibers are acted upon by both centrifugal forces and by the vacuum from the central channel (6) in the secondary impurities removal zone (5).
2. The method for removing impurities according to claim 1, **characterized in that** the particles removed in the primary removal zone (3) and the particles removed in the secondary removal zone (6) are separately taken to a common collection channel (4) and through it together to the central channel (6) of impurities removal.
3. The method for removing impurities according to claim 1 or 2, **characterized in that** the particles being removed are acted upon by a vacuum in the range from 100 to 1000 Pa.
4. The method for removing impurities according to any of the preceding claims, **characterized in that** all the air required to remove impurities from the primary removal zone (3) is sucked in through a sieve whose holes limit the size of the particles being removed by their flow cross-sectional area having a maximum size of 1 mm<sup>2</sup>.
5. A device for removing impurities, especially particles of dust and/or very small fiber portions from a sliver in a spinning unit of an open-end spinning machine comprising a feeding device of sliver assigned to an opening device (2) of the sliver with a rotating opening roller (22) with toothed surface (23) for opening fibers from the supplied sliver in an opening zone (26), whereby the spinning unit further contains a primary impurities removal zone (3) with a sieve and also contains a secondary impurities removal zone (5) both assigned to the toothed surface (23) of the opening roller (22) and both being connected to a vacuum system for impurities removal, **characterized in that the** primary impurities removal zone (3) is situated behind the opening zone (26) and before

the secondary impurities removal zone (5), whereby the width of the primary impurities removal zone (3) corresponds to the working width of the opening roller (22), both impurities removal zones (3, 5) being connected to the vacuum system for impurities removal. 5

6. The device according to claim 5, **characterized in that** the separate discharging channels (32, 51) of the primary and secondary impurities removal zones (3, 5) are guided into a common central channel (6) of the vacuum system for impurities removal, which is provided with a source of vacuum in the range from 100 to 1000 Pa. 10

7. The device according to claim 5 or 6, **characterized in that** the primary impurities removal zone (3) is equipped with a sieve, whereby the maximum size of the individual elementary flow cross-sectional areas of the sieve holes is 1 mm<sup>2</sup>. 15 20

25

30

35

40

45

50

55

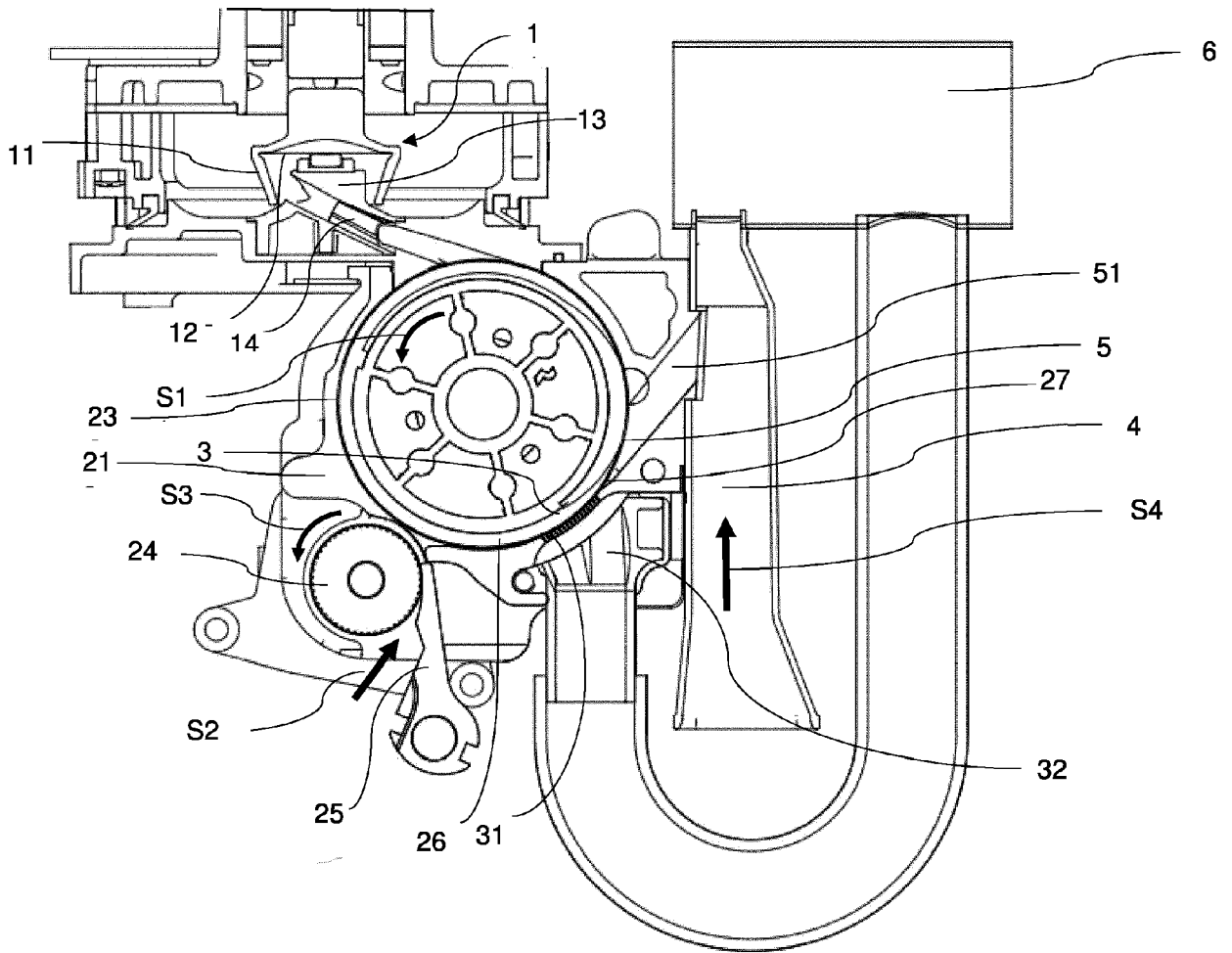
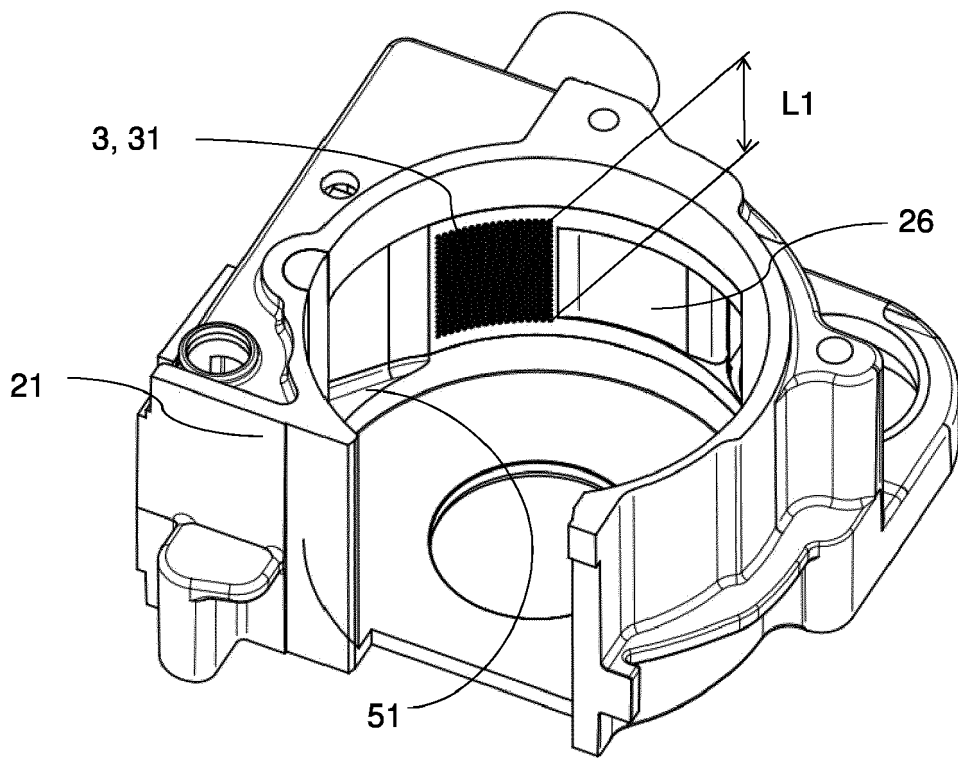

Fig. 1



**Fig. 2**



ANNEX TO THE EUROPEAN SEARCH REPORT  
ON EUROPEAN PATENT APPLICATION NO.

EP 18 21 4370

5

This annex lists the patent family members relating to the patent documents cited in the above-mentioned European search report. The members are as contained in the European Patent Office EDP file on The European Patent Office is in no way liable for these particulars which are merely given for the purpose of information.

22-05-2019

10

15

20

25

30

35

40

45

50

55

Patent document cited in search report	Publication date	Patent family member(s)	Publication date
US 4201037 A	06-05-1980	BE 860136 A	15-02-1978
		BR 7706964 A	04-07-1978
		CH 623855 A5	30-06-1981
		CS 262402 B2	14-03-1989
		DE 2648715 A1	03-05-1978
		FR 2369363 A1	26-05-1978
		GB 1566779 A	08-05-1980
		HK 59080 A	24-10-1980
		IN 147897 B	02-08-1980
		IT 1088077 B	04-06-1985
		JP S5358036 A	25-05-1978
		JP S6052216 B2	18-11-1985
		MY 8100194 A	31-12-1981
		PL 201037 A1	08-05-1978
SU 897116 A3	07-01-1982		
US 4201037 A	06-05-1980		
DE 19851321 A1	27-05-1999	CZ 286088 B6	12-01-2000
		DE 19851321 A1	27-05-1999
		SK 148798 A3	12-07-1999
US 4700431 A	20-10-1987	BR 8503705 A	06-05-1986
		CS 276712 B6	12-08-1992
		DE 3429024 A1	20-02-1986
		EP 0172369 A2	26-02-1986
		HK 100691 A	20-12-1991
		IN 166213 B	31-03-1990
		JP H0373659 B2	22-11-1991
		JP S6147828 A	08-03-1986
		SG 86991 G	14-02-1992
		US 4700431 A	20-10-1987
US 5365640 A	22-11-1994	NONE	

**REFERENCES CITED IN THE DESCRIPTION**

*This list of references cited by the applicant is for the reader's convenience only. It does not form part of the European patent document. Even though great care has been taken in compiling the references, errors or omissions cannot be excluded and the EPO disclaims all liability in this regard.*

**Patent documents cited in the description**

- DE 102008037000 A1 [0004]
- DE 102008026776 A1 [0005]
- US 6321521 B1 [0006]
- CZ 304228B6 [0008]
- CZ 262402 B2 [0009]