



(11) **EP 3 509 167 A1**

(12) **EUROPEAN PATENT APPLICATION**
published in accordance with Art. 153(4) EPC

(43) Date of publication:
10.07.2019 Bulletin 2019/28

(51) Int Cl.:
H01R 13/6474^(2011.01) H01R 12/78^(2011.01)
H01R 12/89^(2011.01)

(21) Application number: **17845804.8**

(86) International application number:
PCT/JP2017/020593

(22) Date of filing: **02.06.2017**

(87) International publication number:
WO 2018/042793 (08.03.2018 Gazette 2018/10)

(84) Designated Contracting States:
AL AT BE BG CH CY CZ DE DK EE ES FI FR GB GR HR HU IE IS IT LI LT LU LV MC MK MT NL NO PL PT RO RS SE SI SK SM TR
Designated Extension States:
BA ME
Designated Validation States:
MA MD

- **OYA, Masaaki**
Tokyo 144-8581 (JP)
- **YAMADA, Yoshiya**
Tokyo 144-8581 (JP)
- **SHIMOYAMA, Takahiro**
Tokyo 144-8581 (JP)
- **YAMAZAKI, Kei**
Tokyo 144-8581 (JP)
- **NAKAO, Satoshi**
Tokyo 144-8581 (JP)

(30) Priority: **30.08.2016 JP 2016168058**

(71) Applicant: **Yamaichi Electronics Co., Ltd.**
Tokyo 144-8581 (JP)

(74) Representative: **Müller-Boré & Partner**
Patentanwälte PartG mbB
Friedenheimer Brücke 21
80639 München (DE)

(72) Inventors:
• **ITO, Daisuke**
Tokyo 144-8581 (JP)

(54) **FLEXIBLE CABLE CONNECTOR, FLEXIBLE CABLE ADAPTER, AND FLEXIBLE CABLE**

(57) The objective of the present invention is to provide a flexible cable connector, a flexible cable adapter, and a flexible cable, wherein characteristic impedance matching in a high frequency band between a pad portion from the flexible cable and contact terminals from the connector has been improved to suppress reflection, thereby reducing the occurrence of a return loss or an insertion loss. The structure for connecting the flexible cable 110 and the flexible cable connector 120 is characterized in that the structure further comprises a high frequency property improving portion 102 formed from an electric conductive resin that is disposed in the surroundings of the flexible cable 110 or the flexible cable connector 120, and in that the high frequency property improving portion 102 and a plurality of conductors 111 are separated from one another by a base material 112 formed from an insulating material.

[Figure 2]

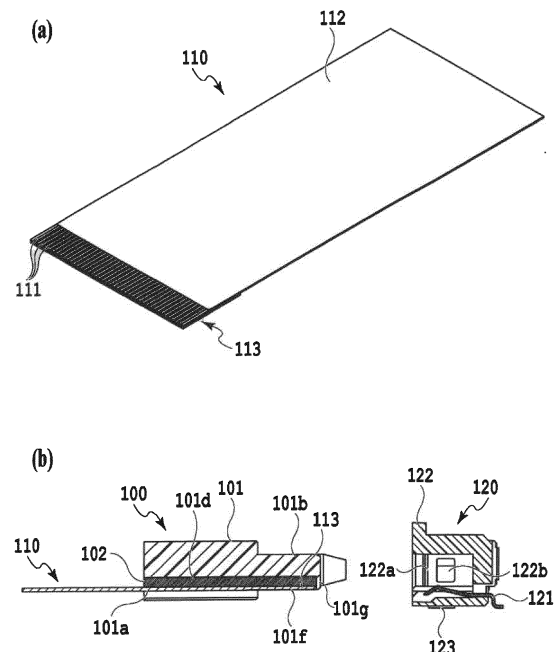

Description**Technical Field**

5 **[0001]** The present invention relates to a flexible cable connector, a flexible cable adapter, and a flexible cable, and in particular to a flexible cable connector, a flexible cable adapter, and a flexible cable that make it possible to improve high-frequency band characteristics.

Background Art

10 **[0002]** As one of methods of electrically connecting circuit boards to each other, there is a connecting method using a flexible cable. As the flexible cable, an FPC (Flexible Printed Circuit) and an FFC (Flexible Flat Cable) are known. The FPC includes a structure in which an adhesive layer is formed on a base material that is flexibly bent and includes a support formed from a thin insulating material with high bending rate, such as polyimide, and a conductive foil is formed
15 on the adhesive layer. The FFC is formed in such a manner that conductors disposed in parallel with one another are vertically sandwiched between film insulators. Further, a flexible cable connector used to connect the flexible cables has been also known.

[0003] As an example of the connecting method using the flexible cable, for example, Patent Literature 1 discloses a method of connecting a flexible cable to a connector mounted on a circuit board. In Patent Literature 1, an upper surface
20 of the connector is covered with an actuator, a shell, and a movable plate each formed from a conductive material, and the actuator, the shell, and the movable plate are grounded to a grounding pattern of a printed wiring board to surely shield electromagnetic waves generated from the connector.

[0004] Further, Patent Literature 2 discloses an invention in which a shield conductor formed from a metallic foil is provided on a rear surface of a flexible cable to block entering of external electromagnetic waves, in order to enhance
25 transmission efficiency of the flexible cable.

Citation List**Patent Literature**

30 **[0005]**

Patent Literature 1: Japanese Patent Application Publication No. 2009-272256

Patent Literature 2: Japanese Patent Application Publication No. 2002-216873

35

Summary of Invention**Technical Problem**

40 **[0006]** In high-speed transmission technology using the flexible cable, a high-frequency band signal is used to increase a transmission speed. To perform stable transmission/reception in a high frequency band, it is necessary to perform characteristic impedance matching of a transmission line. In a case where the characteristic impedance matching is not performable, a return loss or an insertion loss occurs to deteriorate transmission efficiency. In addition, a ripple by reflection at a specific wavelength may occur in the line, which may deteriorate transmission efficiency.

45 **[0007]** On the other hand, the technology that suppresses entering and radiation of external electromagnetic waves by partially disposing a shield member formed from a conductive member has been proposed as described above. The technology, however, is not for impedance matching in the high frequency band between the flexible cable and the connector, and therefore, a return loss or an insertion loss may occur to deteriorate the transmission efficiency.

50 **[0008]** Accordingly, an object of the present invention is to provide a flexible cable connector, a flexible cable adapter, and a flexible cable that improve the characteristic impedance matching in a high frequency band between a pad portion from the flexible cable and contact terminals from the connector to suppresses reflection, thereby reducing occurrence of a return loss and an insertion loss.

Solution to Problem

55 **[0009]** According to the present invention, provided is a structure for connecting a flexible cable and a flexible cable connector in order to solve the above-described issues. The flexible cable includes a plurality of conductors, a base material that is formed from a thin insulating material with high bending rate and aligns, fixes, and holds the plurality of

conductors while insulating the plurality of conductors from one another, and a pad portion that is formed on each of both ends of the base material and aligns and fixes the plurality of conductors exposed, on a surface, to be brought into electric contact with a plurality of contact terminals of the flexible cable connector. The structure further includes a high frequency property improving portion formed from an electric conductive resin that is disposed in surroundings of the flexible cable or the flexible cable connector. The high frequency property improving portion and the plurality of conductors disposed in the pad portion of the flexible cable are separated from one another by the base material formed from the insulating material.

[0010] To solve the above-described issues, a flexible cable adapter according to the present invention receives and fixes an inserted flexible cable and insertably/removably connects the flexible cable to a flexible cable connector. The flexible cable adapter includes a housing that is formed from an insulating material and includes an opening to which the flexible cable is inserted and fixed, and a high frequency property improving portion formed from an electric conductive resin that is disposed on a surface opposite to a surface on which a plurality of conductors exposed on a pad portion of the flexible cable are disposed, in surroundings of the opening of the housing.

[0011] In addition, a front end side of the high frequency property improving portion may be covered with the housing, and the high frequency property improving portion and a plurality of contact terminals of the flexible cable connector may be electrically separated from one another by the housing when the flexible cable adapter is inserted into the flexible cable connector.

[0012] To solve the above-described issues, a flexible cable connector according to the present invention includes an opening to which a flexible cable is insertably/removably connected, and includes a plurality of contact terminals that come into contact with a plurality of conductors exposed on a pad portion of the flexible cable, a base-side housing that aligns, fixes, and holds the plurality of contact terminals while insulating the plurality of contact terminals from one another, and a cover-side housing that is disposed to cover an upper surface of the base-side housing and serves as a high frequency property improving portion formed from an electric conductive resin.

[0013] Further, the base-side housing and the cover-side housing may be integrally molded by two-color molding.

[0014] Further, an insulating member that prevents electric contact with the plurality of contact terminals may be provided on a rear surface on the opening side of the cover-side housing of the flexible cable connector.

[0015] The present invention also includes a flexible cable. More specifically, the flexible cable is insertably/removably connected to an opening of a flexible cable connector, and includes a base material that holds a plurality of conductors, a pad portion that exposes a part of the plurality of conductors on a surface of the base material to bring the part of the plurality of conductors into electric contact with a plurality of contact terminals of the flexible cable connector, and a high frequency property improving portion that is disposed on a rear surface of the base material opposite to the pad portion.

[0016] As a more preferable aspect, the high frequency property improving portion is a conductive adhesive layer to which a conductive filler is added, and a predetermined reinforcing plate is bonded through the conductive adhesive layer.

[0017] As another aspect, the high frequency property improving portion is formed from an electric conductive resin sheet, and the electric conductive resin sheet is bonded to the rear surface of the base material opposite to the pad portion.

[0018] As a more preferable aspect, the electric conductive resin sheet includes an organic conductive polymer layer that is formed on a surface of a base sheet to include a predetermined layer thickness and is disposed oppositely to the rear surface of the base material.

[0019] As a more preferable aspect, a cohesive layer to bond the electric conductive resin sheet is provided between the rear surface of the base material and the conductive polymer layer.

Advantageous Effects of Invention

[0020] According to the present invention, it is possible to provide the flexible cable connector, the flexible cable adapter, and the flexible cable that improve characteristic impedance matching in the high frequency band between the pad portion of the flexible cable and the contact terminals of the connector to suppress reflection, thereby reducing occurrence of a return loss and an insertion loss.

Brief Description of Drawings

[0021]

Figure 1(a) is a perspective view illustrating a state before a flexible cable adapter according to a first embodiment of the present invention is fitted to a flexible cable connector, Figure 1(b) is a perspective view illustrating the state before the flexible cable adapter is fitted to the flexible cable connector illustrated in Figure 1(a) as viewed from a direction opposite to a direction of Figure 1(a), and Figure 1(c) is a perspective view illustrating a state where the flexible cable adapter is fitted to the flexible cable connector.

Figure 2(a) is a perspective view illustrating a flexible cable, and Figure 2(b) is a cross-sectional view taken along

a line IIB-IIB illustrated in Figure 1(a).

Figure 3(a) is a diagram illustrating frequency characteristics of transmission characteristics of an existing flexible cable adapter, Figure 3(b) is a diagram illustrating frequency characteristics of transmission characteristics of the flexible cable adapter according to the first embodiment of the present invention, and Figure 3(c) is a schematic view illustrating a state where the flexible cable is fitted to the flexible cable adapter according to the first embodiment of the present invention.

Figure 4(a) is a perspective view illustrating an exploded state of a flexible cable connector according to a second embodiment of the present invention, Figure 4(b) is a plan view illustrating a rear surface side of a cover-side housing of the flexible cable connector illustrated in Figure 4(a), Figure 4(c) is a perspective view illustrating a state where the flexible cable connector illustrated in Figure 4(a) is assembled, and Figure 4(d) is a cross-sectional view taken along a line IVD-IVD illustrated in Figure 4(c).

Figure 5(a) is a diagram illustrating frequency characteristics of transmission characteristics of an existing flexible cable connector, and Figure 5(b) is a diagram illustrating frequency characteristics of transmission characteristics of the flexible cable connector according to the second embodiment of the present invention.

Figure 6(a) is a cross-sectional view illustrating a state where an existing flexible cable is fitted to a flexible cable connector, Figure 6(b) is a cross-sectional schematic view taken along a line VIB-VIB illustrated in Figure 6(a), Figure 6(c) is a cross-sectional view illustrating a state where a flexible cable according to a third embodiment of the present invention is fitted to the flexible cable connector, Figure 6(d) is a cross-sectional schematic view taken along a line VID-VID illustrated in Figure 6(c), Figure 6(e) is a diagram illustrating a state where a flexible cable according to a fourth embodiment of the present invention is fitted to the flexible cable connector, and Figure 6(f) is a cross-sectional schematic view taken along a line VIF-VIF illustrated in Figure 6(e).

Figure 7(a) is a diagram illustrating frequency characteristics of transmission characteristics of an existing flexible cable, Figure 7(b) is a diagram illustrating frequency characteristics of transmission characteristics of the flexible cable according to the third embodiment of the present invention, and Figure 7(c) is a diagram illustrating frequency characteristics of transmission characteristics of the flexible cable according to the fourth embodiment of the present invention.

Figure 8(a) is a schematic view illustrating a cross-section of a flexible portion of a Type-A FPC, Figure 8(b) is a schematic view illustrating a cross-section of a pad portion of the FPC illustrated in Figure 8(a), Figure 8(c) is a schematic view illustrating a cross-section of a flexible portion of a Type-B FPC, and Figure 8(d) is a schematic view illustrating a cross-section of a pad portion of the FPC illustrated in Figure 8(c).

Figure 9 is a diagram illustrating comparison in insertion loss between the Type-A FPC and the Type-B FPC.

Figure 10(a) is a partial enlarged front view illustrating a front surface side of the flexible cable according to the fifth embodiment of the present invention, Figure 10(b) is a partial enlarged back view illustrating a rear surface side, and Figure 10(c) is a right side view of Figure 10(a).

Figure 11 is a partial enlarged cross-sectional view illustrating a pad portion of the flexible cable according to the fifth embodiment in an enlarged manner.

Figure 12 is a graph illustrating comparison in insertion loss of the flexible cable according to the fifth embodiment.

Description of Embodiments

[0022] Embodiments of the present invention are described below with reference to drawings.

[0023] Note that concepts of a vertical direction in the following description correspond to a vertical direction in accompanying drawings, and illustrate not absolute positional relationship of members but relative positional relationship of the members. Further, in the following description, a connector insertion direction is defined as "front end", a direction opposite to the connector insertion direction is defined as "rear end", and a "lateral" direction is defined as a direction orthogonal to the connector insertion direction; however, these definitions do not indicate absolute positional relationship.

[0024] A first embodiment of the present invention is first described.

[0025] In Figure 1(a) to Figure 2(b), a flexible cable adapter 100 according to the first embodiment of the present invention receives and fixes an inserted flexible cable 110 such as an FPC and an FFC, and insertably/removably connects the flexible cable 110 to a flexible cable connector 120.

[0026] The flexible cable adapter 100 includes a housing 101 formed from an insulating material, and a high frequency property improving portion 102 formed from an electric conductive resin. The housing 101 has a flat rectangular-parallelepiped shape formed from a synthetic resin molded product, and includes on a bottom part (lower surface side illustrated in Figure 2(b)), an accommodation recessed portion 101d in which the high frequency property improving portion 102 is accommodated.

[0027] With reference to Figure 2(b) together, the accommodation recessed portion 101d is a recessed portion that is made lower by one step than the bottom part of the housing 101 in an upward direction, and has a downward U-shaped cross-section that includes side wall parts 101e and 101e on right and left ends. A bottom wall (upper wall in

Figure 2(b)) of the accommodation recessed portion 101d is formed horizontally from a rear end (left end in Figure 2(b)) toward a front end (right end in Figure 2(b)) of the housing 101, and a perpendicular front wall part 101f with which a front end of the high frequency property improving portion 102 comes into contact is formed on the front end side of the accommodation recessed portion 101d.

5 [0028] In the embodiment, a depth of the accommodation recessed portion 101d (height of front wall part 101f) is substantially equal to a thickness obtained by superimposing the high frequency property improving portion 102 and the flexible cable 110. Accordingly, as illustrated in Figure 2(b), when the high frequency property improving portion 102 and the flexible cable 110 are accommodated in the accommodation recessed portion 101d, the bottom surface of the housing 101 and the bottom surface of the flexible cable 110 are in the same plane.

10 [0029] An insertion portion 101b to be inserted into the flexible cable connector 120 is formed on the front end side of the housing 101. The insertion portion 101b substantially horizontally extends from the front end (right end in Figure 2(b)) of the housing 101 as a base end. A front end of the insertion portion 101b includes an insulating resin portion 101g that prevents the front end surface of the high frequency property improving portion 102 from being exposed. Therefore, since the front end of the high frequency property improving portion 102 including electric conductivity is covered with the insulating resin portion 101g, it is possible to prevent the high frequency property improving portion 102 from coming into contact with contact terminals 121 to cause short circuit when the flexible cable adapter 100 is inserted into or removed from the flexible cable connector 120.

15 [0030] Two lock portions 101c are formed on respective side surfaces of the housing 101. The two lock portions 101c are to engage with two engagement portions 122b of the flexible cable connector 120 described later. In the embodiment, the lock portions 101c are each formed from an elastically deformable engagement piece, and elastically engage with the respective engagement portions 122b of the flexible cable connector 120.

20 [0031] As the electric conductive resin forming the high frequency property improving portion 102, an essential electric conductive resin that includes electric conductivity derived from an essential polymer structure, and a composite conductive polymer that expresses electric conductivity when a nonelectric conductive resin is filled with an inorganic electric conductor are known; however, the electric conductive resin is not particularly limited.

25 [0032] However, attention should be paid to the fact that electric conductivity of the electric conductive resin forming the high frequency property improving portion 102 and a distance between the high frequency property improving portion 102 and each of a plurality of conductors 111 influence transmission characteristics of a high-frequency band signal to be transmitted and received described later.

30 [0033] As illustrated in Figure 2(a), the flexible cable 110 mainly includes the plurality of conductors 111, a base material 112, and a pad portion 113. The base material 112 is made of an insulating material such as LCP (Liquid Crystal Polymer) and a polyimide, and aligns, fixes, and holds the plurality of conductors 111 while insulating the plurality of conductors 111 from one another. The pad portion 113 is formed on each of both ends of the base material 112, and aligns and fixes the plurality of conductors 111 that are exposed, on a surface, to be brought into electric contact with outside. In the embodiment, the flexible cable 110 is fixed while being integrally bonded with the high frequency property improving portion 102 by thermal fusion. Note that the method of fixing the flexible cable 110 and the high frequency property improving portion 102 is not limited to the method described in the present embodiment.

35 [0034] As illustrated in Figure 1(a) to Figure 2(b), the flexible cable connector 120 mainly includes the plurality of contact terminals 121, a connector housing 122, and two fixing fittings 123. The plurality of contact terminals 121 come into electric contact with the plurality of conductors 111 exposed on the pad portion 113, and are connected to a land pattern of a circuit board (not illustrated) by soldering, etc. The connector housing 122 aligns, fixes, and holds the plurality of contact terminals 121 while insulating the plurality of contact terminals 121 from one another. The fixing fittings 123 are disposed on respective side surfaces of the connector housing 122, fix the flexible cable connector 120 to the circuit board, and are each formed from a metallic material. The connector housing 122 is formed from an insulating material, and includes, on a rear end side, an opening 122a to which the insertion portion 101b of the housing 101 of the flexible cable adapter 100 is inserted. Further, the two engagement portions 122b that engage with the respective lock portions 101c of the housing 101 of the flexible cable adapter 100 are formed on respective side surfaces inside the opening 122a.

40 [0035] As illustrated in Figure 2(b), the flexible cable 110 that has been inserted into an opening 101a of the housing 101 of the flexible cable adapter 100 and has been fixed reaches the vicinity of the insertion portion 101b on the front end side, and the plurality of conductors 111 disposed in the pad portion 113 of the flexible cable 110 are exposed on the lower surface illustrated in Figure 2(b). The plurality of conductors 111 exposed on the lower surface come into contact with and are electrically connected to the plurality of contact terminals 121 of the flexible cable connector 120 in a fitting state illustrated in Figure 1(c).

45 [0036] At this time, as illustrated in Figure 2(b), the high frequency property improving portion 102 formed from the electric conductive resin of the flexible cable adapter 100 is disposed so as to cover an upper surface of the pad portion 113 of the flexible cable 110 illustrated in Figure 2(b). As described above, since the plurality of conductors 111 of the flexible cable 110 are disposed on the lower surface of Figure 2(b), the high frequency property improving portion 102 is separated from the plurality of conductors 111 of the flexible cable 110 by the base material 112 formed from an

insulating material. When the high frequency property improving portion 102 formed from the electric conductive resin is disposed so as to be separated to some extent from the plurality of conductors 111 disposed in the pad portion 113 of the flexible cable 110 in such a manner, effects described later are achievable.

5 [0037] It is found from Figure 3(a) that an insertion loss ripple occurs in a predetermined band in a case of an existing flexible cable adapter not including the high frequency property improving portion 102 formed from an electric conductive resin. Further, it is found that large disturbance of a waveform similarly occurs in a predetermined band in terms of a return loss, far-end crosstalk, and near-end crosstalk. In such a case, characteristic impedance is not matched to deteriorate transmission characteristics, which may disable signal transmission/reception.

10 [0038] In contrast, in the case of the flexible cable adapter 100 according to the first embodiment of the present invention, it is found from Figure 3(b) that large disturbance of a waveform such as a ripple does not occur in any of an insertion loss, a return loss, far-end crosstalk, and near-end crosstalk, and the transmission characteristics are not deteriorated.

15 [0039] The schematic view illustrated in Figure 3(c) is illustrated vertically reversely from the diagram illustrated in Figure 1(b) for convenience of description. An FPC 300 as an example of the flexible cable 110 includes a plurality of conductors 301, an LCP layer 302, an adhesive layer 303, and a reinforcing plate layer 304 in order from above, and the high frequency property improving portion 102 formed from an electric conductive resin of the flexible cable adapter 100 is disposed outside the reinforcing plate layer 304 of the FPC 300. Note that the FPC is used as the flexible cable 110 in this example; however, an FFC may be used as the flexible cable 110.

20 [0040] It was found from a result of the examination that the transmission characteristics in the high frequency band are improved when the high frequency property improving portion 102 formed from an electric conductive resin is disposed so as to be separated by a certain distance from the plurality of conductors 111, as illustrated in Figure 3(a) and Figure 3(b). Further, it was found that the distance is varied depending on the electric conductivity of the electric conductive resin and the frequency of the signal to be transmitted/received. It was found that the transmission characteristics in the high frequency band are improved by separating the high frequency property improving portion 102 from the plurality of

25 conductors 111 by a distance obtained by adding thicknesses of the LCP layer 302, the adhesive layer 303, and the reinforcing plate layer 304 used as insulating members of the FPC 300.
[0041] As described above, the flexible cable adapter 100 according to the first embodiment of the present invention makes it possible to improve characteristic impedance matching in the high frequency band between the pad portion of the flexible cable and the contact terminals of the connector to suppress reflection, thereby reducing occurrence of a return loss and an insertion loss.

30 [0042] Next, a second embodiment of the present invention is described.

[0043] In Figure 4(a) to Figure 4(d), the flexible cable 110 is insertably/removably connected to a flexible cable connector 400 according to the second embodiment of the present invention.

35 [0044] As illustrated in Figure 4(a), the flexible cable connector 400 includes a plurality of contact terminals 401, a base-side housing 402, a cover-side housing 403, an insulating tape 404, and two metal fixing fittings 405. The base-side housing 402 holds the plurality of contact terminals 401. The cover-side housing 403 is disposed so as to cover an upper surface of the base-side housing 402. The insulating tape 404 is stuck to a rear surface of the cover-side housing 403. The two metal fixing fittings 405 fix, to a circuit board (not illustrated), the base-side housing 402 and the cover-side housing 403 that are bonded to each other.

40 [0045] The plurality of contact terminals 401 are each formed from a metallic material such as a copper with gold plating, are electrically connected to the plurality of conductors 111 exposed on the pad portion 113 of the flexible cable 110, and are connected to a land pattern of the circuit board (not illustrated) by soldering, etc.

45 [0046] The base-side housing 402 is a molded product formed from an insulating material and has a laterally-long flat shape. The base-side housing 402 is notched to have an L-shaped cross-section from an upper surface to a front surface. The plurality of contact terminals 401 are aligned and fixed to a horizontal bottom part 406a of a notch 406 of the base-side housing 402 while being insulated from one another. Base-side fixing grooves 402a to which the respective fixing fittings 405 described later are inserted are formed on right and left ends of the base-side housing 402.

50 [0047] The cover-side housing 403 is formed from an electric conductive resin functioning as a high frequency property improving portion, and has a laterally-long flat shape similar to the base-side housing 402. The cover-side housing 403 includes cover-side fixing grooves 403a to which the respective fixing fittings 405 described later are inserted, at positions on the same line as the positions of the base-side fixing grooves 402a.

55 [0048] Accordingly, when the base-side housing 402 and the cover-side housing 403 are assembled such that the cover-side housing 403 is located on the base-side housing 402, the base-side fixing grooves 402a and the cover-side fixing grooves 403a communicate with each other on the same line, and the two fixing fittings 405 are pressed into and fixed to the grooves on the respective sides.

[0049] When the cover-side housing 403 is assembled on the base-side housing 402, an opening 400a to which the flexible cable 110 is inserted is formed on the rear end side (left side in Figure 4(d)) of the flexible cable connector 400. Note that, in this example, the two fixing fittings 405 are pressed into and fixed to the respective side surfaces; however,

the fixing method is not limited thereto, and the two fixing fittings 405 may be fixed by other fixing methods, for example, an adhesive. Further, the base-side housing 402 and the cover-side housing 403 may be integrally molded by two-color molding.

5 [0050] The insulating tape 404 is a sheet formed from an insulating material, and is stuck to a rear surface of the cover-side housing 403 on the opening 400a side. This makes it possible to prevent erroneous electric contact between the plurality of contact terminals 401 and the cover-side housing 403 formed from an electric conductive resin. Note that, in a case where there is no possibility that the plurality of contact terminals 401 and the cover-side housing 403 formed from an electric conductive resin come into contact with each other because of the structure, it is unnecessary to stick the insulating tape 404. Further, as another method, an inverse-V shaped notch may be formed on the rear surface of the cover-side housing 403 from both ends toward a center in a width direction (lateral direction in Figure 4(d)), a clearance may be provided between the contact terminals 401 and the cover-side housing 403 to prevent short circuit.

10 [0051] It is found from Figure 5(a) that an insertion loss ripple occurs in a predetermined band in a case of an existing flexible cable adapter not including the cover-side housing 403 that is formed from an electric conductive resin and functions as the high frequency property improving portion. Further, it is found that large disturbance of a waveform similarly occurs in a predetermined band in terms of a return loss, far-end crosstalk, and near-end crosstalk. In such a case, as with the first embodiment, characteristic impedance is not matched to deteriorate transmission performance, which may disable signal transmission/reception.

15 [0052] In contrast, in the case of the flexible cable connector 400 according to the second embodiment of the present invention, it is found from Figure 5(b) that large disturbance of a waveform such as a ripple does not occur in any of an insertion loss, a return loss, far-end crosstalk, and near-end crosstalk, and the transmission performance is not deteriorated.

20 [0053] As described above, in the flexible cable connector 400 according to the second embodiment of the present invention, the cover-side housing 403 functioning as the high frequency property improving portion and the plurality of conductors 111 disposed in the pad portion 113 of the flexible cable 110 are separated from one another by the base material 112 formed from an insulating material as with the first embodiment. Therefore, it is possible to achieve effects similar to the effects of the first embodiment.

25 [0054] Next, a third embodiment and a fourth embodiment of the present invention are described.

30 [0055] In Figure 6(a) and Figure 6(b), an existing flexible cable connector 620 mainly includes a plurality of contact terminals 621, a connector housing 622, and the two fixing fittings 405. The connector housing 622 aligns, fixes, and holds the plurality of contact terminals 621 while insulating the plurality of contact terminals 621 from one another. The two fixing fittings 405 are disposed on respective side surfaces of the connector housing 622 and fix the flexible cable connector 620 to a circuit board. The connector housing 622 is formed from an insulating material, and an opening 622a to which, for example, the FPC 300 as the flexible cable 110 is inserted is formed on a rear end side of the connector housing 622.

35 [0056] As illustrated in Figure 6(a) and Figure 6(b), the existing FPC 300 is inserted into the opening 622a of the flexible cable connector 620. The plurality of conductors 301 exposed on a surface of the pad portion of the FPC 300 appear on the lower surface as illustrated in Figure 6(a), and come into contact with the plurality of contact terminals 621. Moreover, a surface on a side opposite to the side where the plurality of conductors 301 are exposed on the pad portion of the FPC 300 is in contact with an upper surface side of the connector housing 622 in the opening 622a of the flexible cable connector 620.

40 [0057] The schematic view illustrated in Figure 6(b) is illustrated vertically reversely from the diagram illustrated in Figure 6(a) for convenience of description. In Figure 6(b), the existing FPC 300 includes the plurality of conductors 301, the LCP layer 302, the adhesive layer 303, and the reinforcing plate layer 304 in order from above, and outside of the reinforcing plate layer 304 is in contact with the upper surface of the connector housing 622.

45 [0058] In Figure 6(c) and Figure 6(d), a flexible cable 600 according to the third embodiment of the present invention is different from the existing FPC 300 in that a conductive filler is added to an adhesive layer 603 and the adhesive layer 603 functions as the high frequency property improving portion, but otherwise the configurations are the same. The same components are denoted by the same reference numerals and description thereof is omitted. Note that the adhesive layer 603 of the flexible cable 600 according to the present embodiment is an adhesive layer to which the conductive filler is added; however, electric conductivity may be added by other methods without limitation as long as the adhesive layer 603 functions as the high frequency property improving portion formed from an electric conductive resin.

50 [0059] In Figure 6(e) and Figure 6(f), a flexible cable 610 according to the fourth embodiment of the present invention is different from the existing FPC 300 in that the reinforcing plate layer 614 includes an electric conductive resin sheet and functions as the high frequency property improving portion, but otherwise the configurations are the same. The same components are denoted by the same reference numerals and description thereof is omitted. Note that the reinforcing plate layer 614 of the flexible cable 610 according to the present embodiment includes the electric conductive resin sheet; however, electric conductivity may be added by other methods without limitation as long as the reinforcing plate layer 614 functions as the high frequency property improving portion formed from an electric conductive resin.

[0060] It is found from Figure 7(a) that an insertion loss ripple occurs in a predetermined band in a case of the existing FPC 300 not including the high frequency property improving portion formed from an electric conductive resin. Further, it is found that large disturbance of a waveform similarly occurs in a predetermined band in terms of a return loss, far-end crosstalk, and near-end crosstalk. In such a case, as with the first and second embodiments, characteristic impedance is not matched to deteriorate transmission performance, which may disable signal transmission/reception.

[0061] In contrast, in the case of the flexible cable 600 according to the third embodiment of the present invention illustrated in Figure 7(b) and in the case of the flexible cable 610 according to the fourth embodiment of the present invention illustrated in Figure 7(c), it is found that large disturbance of a waveform such as a ripple does not occur in any of an insertion loss, a return loss, far-end crosstalk, and near-end crosstalk, and the transmission performance is not deteriorated.

[0062] As described above, in the flexible cable 600 according to the third embodiment of the present invention and the flexible cable 610 according to the fourth embodiment of the present invention, the adhesive layer 603 or the reinforcing plate layer 614 functioning as the high frequency property improving portion is separated from the plurality of conductors 301 disposed in the pad portion of the flexible cable by the LCP layer 302 formed from an insulating material, as with the first embodiment. Therefore, it is possible to achieve effects similar to the effects of the first and second embodiments.

[0063] Next, variation of an insertion loss depending on a thickness of the FPC is described.

[0064] In Figure 8(a), a flexible portion of Type-A FPC 800 includes a coverlay polyimide layer 801, a low-loss adhesive layer 802, a plurality of conductors 803, an LCP layer 804, a GND layer 805, a coverlay adhesive layer 806, and a coverlay polyimide layer 807 in order from above. A configuration in which the conductors 803 of signal lines are surrounded by conductors 803' of GND lines disposed on both sides of each of the conductors 803 and by the GND layer 805 as a second conductive layer is called a microstrip line that suppresses emission and radiation of noise from the signal lines and is excellent in high-frequency transmission characteristics.

[0065] In Figure 8(b), a pad portion of the Type-A FPC 800 is configured by removing the coverlay polyimide layer 801 and the low-loss adhesive layer 802 from the flexible portion illustrated in Figure 8(a), and adding an adhesive layer 808 and a reinforcing plate layer 809 to a surface on a side opposite to the side where the coverlay polyimide layer 801 and the low-loss adhesive layer 802 are removed.

[0066] In Figure 8(c), a flexible portion of Type-B FPC 810 includes a configuration similar to the configuration of the Type-A FPC 800 but is different from the Type-A FPC 800 in that a total thickness of a coverlay adhesive layer 816 and a coverlay polyimide layer 817 is made thick by α . The similar components are denoted by the similar reference numerals and description thereof is omitted.

[0067] In Figure 8(d), a pad portion of the Type-B FPC 810 is configured by removing the coverlay polyimide layer 801 and the low-loss adhesive layer 802 from the flexible portion; however, an adhesive layer and a reinforcing plate layer are not added because of specification unlike the pad portion of the Type-A FPC 800 illustrated in Figure 8(b). Accordingly, when a thickness Z of the pad portion of the Type-A FPC 800 and a thickness $Z'+\alpha$ of the pad portion of the Type-B FPC 810 are compared, the thickness Z of the pad portion of the Type-A FPC 800 is slightly larger than the thickness $Z'+\alpha$ of the pad portion of the Type-B FPC 810.

[0068] Figure 9 is a diagram illustrating comparison in insertion loss between the Type-A FPC and the Type-B FPC.

[0069] As illustrated in Figure 9, the insertion loss of the Type-B FPC 810 including the smaller thickness is lower than the insertion loss of the Type-A FPC 800 when compared. It was found from a result of the examination that, when the thickness of the FPC is reduced, the characteristic impedance becomes lower, and the impedance is not matched to increase the insertion loss. Accordingly, it was found that, when the thickness of the FPC is selected by taking these points into consideration, it is possible to further improve the high-frequency band characteristics.

[0070] Next, a flexible cable 500 according to the fifth embodiment of the present invention is described with reference to Figure 10 and Figure 11. The flexible cable 500 includes a flexible cable body 510 (hereinafter, simply referred to as FPC body 510) that includes a pad portion P on one end (upper end in Figure 10(A)) on the front surface side. An electric conductive resin sheet 530 as the high frequency property improving portion is provided so as to cover the pad portion P, on a rear surface (side illustrated in Figure 10(b)) of the FPC body 510.

[0071] The FPC body 510 has a linear strip shape in the fifth embodiment; however, the FPC body 510 may have, for example, an L shape or a crank shape. Likewise, the pad portion P is provided so as to be exposed on a front surface side of the FPC body 510; however, the pad portion may be provided on a rear surface side of the FPC body 510 or may be provided on each of the front surface side and the rear surface side. Furthermore, the pad portion P may be provided not only at a front end and a rear end but also at a side end, and the position thereof is optionally changeable based on a specification of a connector to be connected.

[0072] The FPC body 510 includes a base material 511 formed from an insulating resin sheet, and coverlays 513 and 514 that are disposed on respective surfaces of the base material 511. A conductor 512 is disposed on each of a front surface (upper surface in this embodiment) and a rear surface (lower surface in this embodiment) of the base material 511. The conductor 512 is a metallic foil formed in a predetermined circuit pattern, and a part of the conductor 512 exposed on the front surface serves as the pad portion P.

[0073] In the fifth embodiment, the coverlays 513 and 514 are optional components, and description of the structure is omitted because the structure is considered substantially the same as the structure illustrated in Figure 8. In the FPC body 510, the coverlay 514 on the rear surface may be omitted; however, if the coverlay 514 is omitted, it is necessary to bond, for insulation, the electric conductive resin sheet 530 to the rear surface of the base material 511 over the entire rear surface of the FPC body.

[0074] The fifth embodiment is characterized in that the electric conductive resin sheet 530 is provided on the rear surface of the FPC body 510 opposite to the pad portion P. In the fifth embodiment, as the electric conductive resin sheet 530, an electric conductive resin sheet in which a conductive polymer layer 532 is formed to include a predetermined layer thickness (0.1 μm or more as preferable layer thickness), on a surface (upper surface in Figure 11) of a base sheet 531 formed from a synthetic resin, is used.

[0075] In the fifth embodiment, an organic electric conductive material excellent in environment resistance (heat resistance and chemical resistance) is most preferably used for the electric conductive resin sheet 530; however, other conductive materials may be used irrespective of an organic or inorganic material. In other words, a resin sheet including a conductive filler such as carbon, a sheet with a metal vapor-deposited film, a sheet coated with carbon nanotube (CNT), etc. can be used.

[0076] In the electric conductive resin sheet 530, the conductive polymer layer 532 is disposed on the rear surface of the FPC body 510 opposite to the pad portion P. In this embodiment, the electric conductive resin sheet 530 includes an area larger than an area of the pad portion P; however, the size of the electric conductive resin sheet 530 can be optionally changed based on a specification as long as the electric conductive resin sheet 530 is disposed on the rear surface opposite to the pad portion P.

[0077] As a more preferable aspect, a cohesive layer 520 to bond the electric conductive resin sheet 530 is preferably provided between the rear surface of the FPC body 510 and the conductive polymer layer 532. It is sufficient to provide the cohesive layer 520 on one of the rear surface of the FPC body 510 and the front surface of the conductive polymer layer 532 of the electric conductive resin sheet 530.

[0078] As illustrated in Figure 12, it was found that the impedance are matched and an insertion loss is reduced in the flexible cable including the electric conductive resin sheet 530, from comparison in insertion loss between the flexible cable (Example) including the electric conductive resin sheet 530 and a flexible cable (Comparative Example) not including the electric conductive resin sheet 530.

[0079] Accordingly, integrally bonding the electric conductive resin sheet 530 including the organic conductive polymer layer 532 to the rear surface of the FPC body 510 opposite to the pad portion P makes it possible to improve high-frequency characteristics.

[0080] As described above, the flexible cable connector, the flexible cable adapter, and the flexible cable according to the present invention make it possible to improve the characteristic impedance matching in the high frequency band between the pad portion of the flexible cable and the contact terminals of the connector to suppress reflection, thereby reducing occurrence of a return loss and an insertion loss.

Reference Signs List

[0081]

100	Flexible cable adapter
101	Housing
101a, 122a, 400a, 622a	Opening
101b	Insertion portion
101c	Lock portion
101d	Accommodation recessed portion
101e	Side wall part
101f	Front wall part
101 g	Insulating resin portion
102	High frequency property improving portion
110, 600, 610, 500	Flexible cable
111, 301, 803, 803'	Conductor
112	Base material
113	Pad portion
120, 400, 620	Flexible cable connector
121, 401, 621	Contact terminal
122, 622	Connector housing
122b	Engagement portion

	123, 405	Fixing fitting
	300, 800, 810	FPC
	302, 804	LCP layer
	303, 603, 808	Adhesive layer
5	304, 614, 809	Reinforcing plate layer
	402	Base-side housing
	402a	Base-side fixing groove
	403	Cover-side housing
	403a	Cover-side fixing groove
10	404	Insulating tape
	406	Notch
	406a	Bottom part
	510	FPC body
	520	Adhesive layer
15	530	Electric conductive resin sheet
	531	Base sheet
	532	Conductive polymer layer
	801, 807, 817	Coverlay polyimide layer
	802	Low-loss adhesive layer
20	805	GND layer
	806, 816	Coverlay adhesive layer

Claims

- 25
- 30
- 35
- 40
- 45
- 50
- 55
1. A structure for connecting a flexible cable and a flexible cable connector, the flexible cable including a plurality of conductors, a base material that is formed from a thin insulating material with high bending rate and aligns, fixes, and holds the plurality of conductors while insulating the plurality of conductors from one another, and a pad portion that is formed on each of both ends of the base material and aligns and fixes the plurality of conductors exposed, on a surface, to be brought into electric contact with a plurality of contact terminals of the flexible cable connector, the structure further comprising a high frequency property improving portion formed from an electric conductive resin that is disposed in surroundings of the flexible cable or the flexible cable connector, wherein the high frequency property improving portion and the plurality of conductors disposed in the pad portion of the flexible cable are separated from one another by the base material formed from the insulating material.
 2. A flexible cable adapter that receives and fixes an inserted flexible cable and insertably/removably connects the flexible cable to a flexible cable connector, the flexible cable adapter comprising:
 - a housing that is formed from an insulating material and includes an opening to which the flexible cable is inserted and fixed; and
 - a high frequency property improving portion formed from an electric conductive resin that is disposed on a surface opposite to a surface on which a plurality of conductors exposed on a pad portion of the flexible cable are disposed, in surroundings of the opening of the housing.
 3. The flexible cable adapter according to claim 2, wherein a front end side of the high frequency property improving portion is covered with the housing, and the high frequency property improving portion and a plurality of contact terminals of the flexible cable connector are electrically separated from one another by the housing when the flexible cable adapter is inserted into the flexible cable connector.
 4. A flexible cable connector that includes an opening to which a flexible cable is insertably/removably connected, the flexible cable connector comprising:
 - a plurality of contact terminals that come into contact with a plurality of conductors exposed on a pad portion of the flexible cable;
 - a base-side housing that aligns, fixes, and holds the plurality of contact terminals while insulating the plurality of contact terminals from one another; and
 - a cover-side housing that is disposed to cover an upper surface of the base-side housing and serves as a high

frequency property improving portion formed from an electric conductive resin.

5 5. The flexible cable connector according to claim 4, wherein the base-side housing and the cover-side housing are integrally molded by two-color molding.

6. The flexible cable connector according to claim 4, wherein an insulating member that prevents electric contact with the plurality of contact terminals is provided on a rear surface on the opening side of the cover-side housing of the flexible cable connector.

10 7. A flexible cable that is insertably/removably connected to an opening of a flexible cable connector, the flexible cable comprising:

a base material that holds a plurality of conductors;

15 a pad portion that exposes a part of the plurality of conductors on a surface of the base material to bring the part of the plurality of conductors into electric contact with a plurality of contact terminals of the flexible cable connector; and

a high frequency property improving portion that is disposed on a rear surface of the base material opposite to the pad portion.

20 8. The flexible cable according to claim 7, wherein the high frequency property improving portion is a conductive adhesive layer to which a conductive filler is added, and a predetermined reinforcing plate is bonded through the conductive adhesive layer.

25 9. The flexible cable according to claim 7, wherein the high frequency property improving portion is formed from an electric conductive resin sheet, and the electric conductive resin sheet is bonded to the rear surface of the base material opposite to the pad portion.

30 10. The flexible cable according to claim 9, wherein the electric conductive resin sheet includes an organic conductive polymer layer that is formed on a surface of a base sheet to include a predetermined layer thickness and is disposed oppositely to the rear surface of the base material.

35 11. The flexible cable according to claim 10, wherein a cohesive layer to bond the electric conductive resin sheet is provided between the rear surface of the base material and the conductive polymer layer.

[Figure 1]

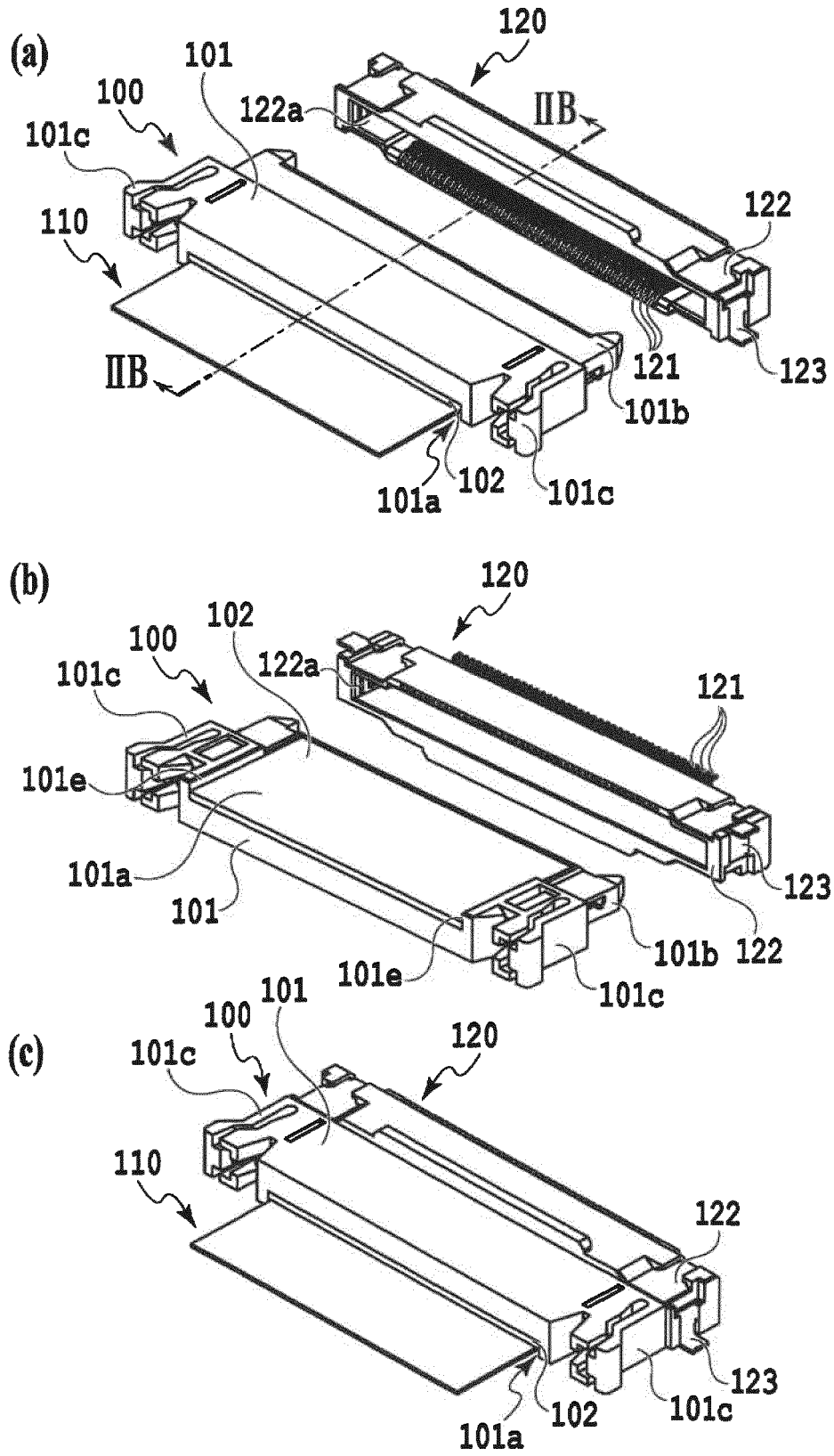

[Figure 2]

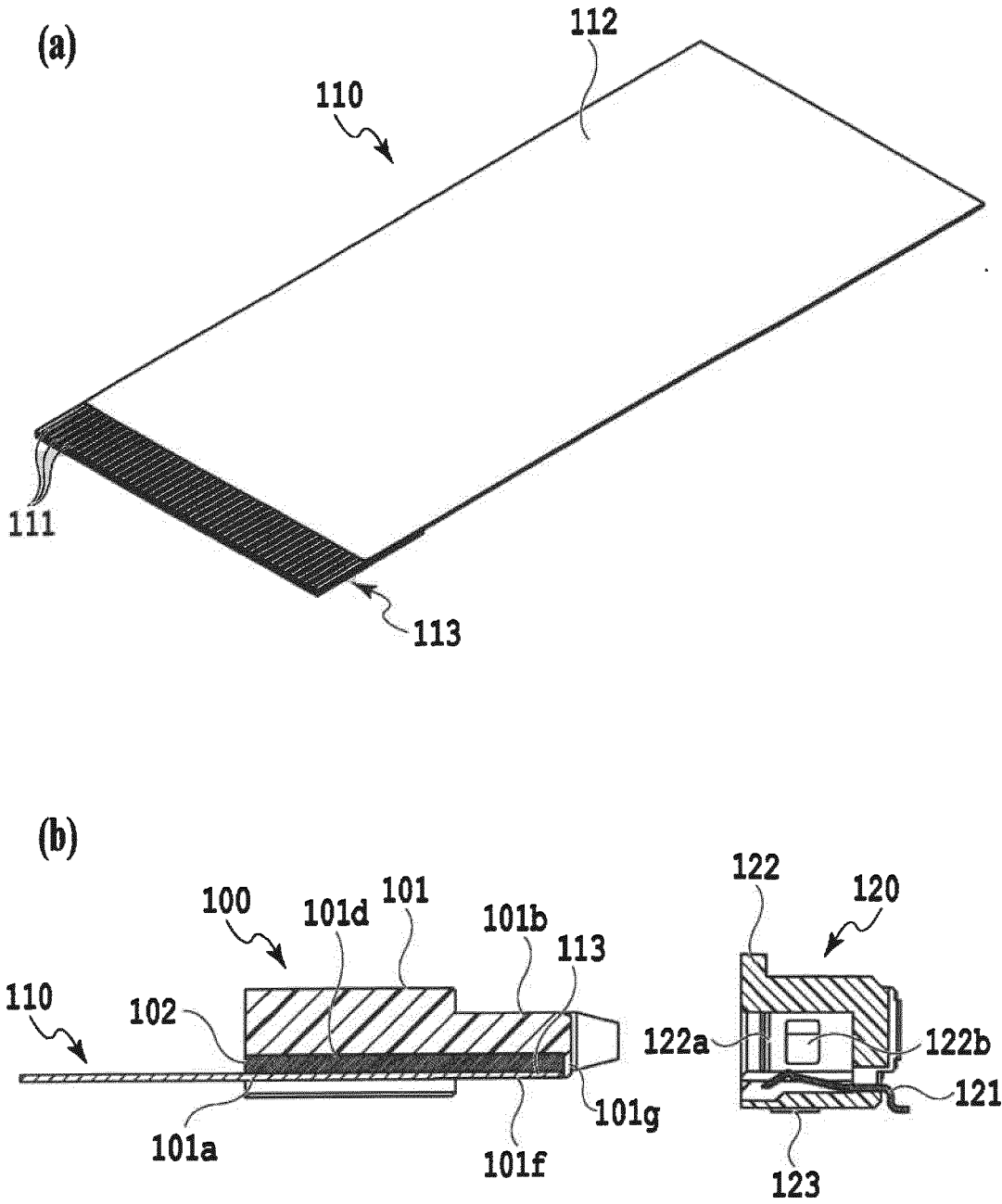

[Figure 3]

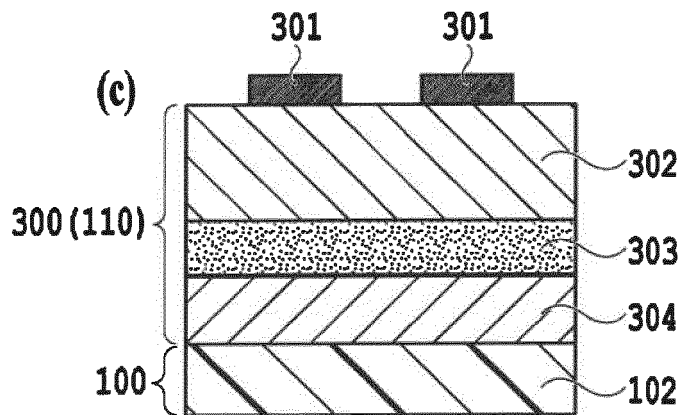
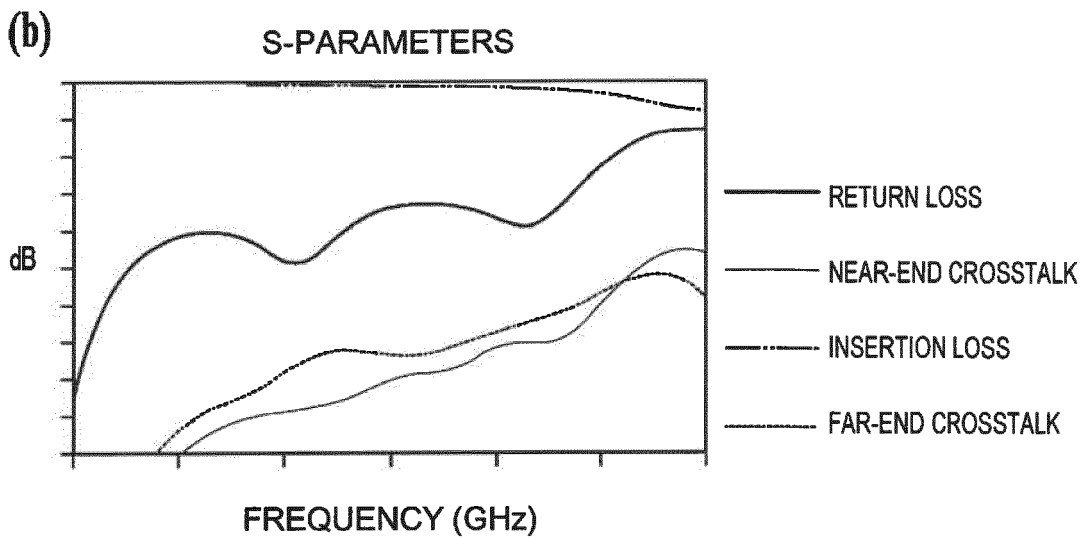
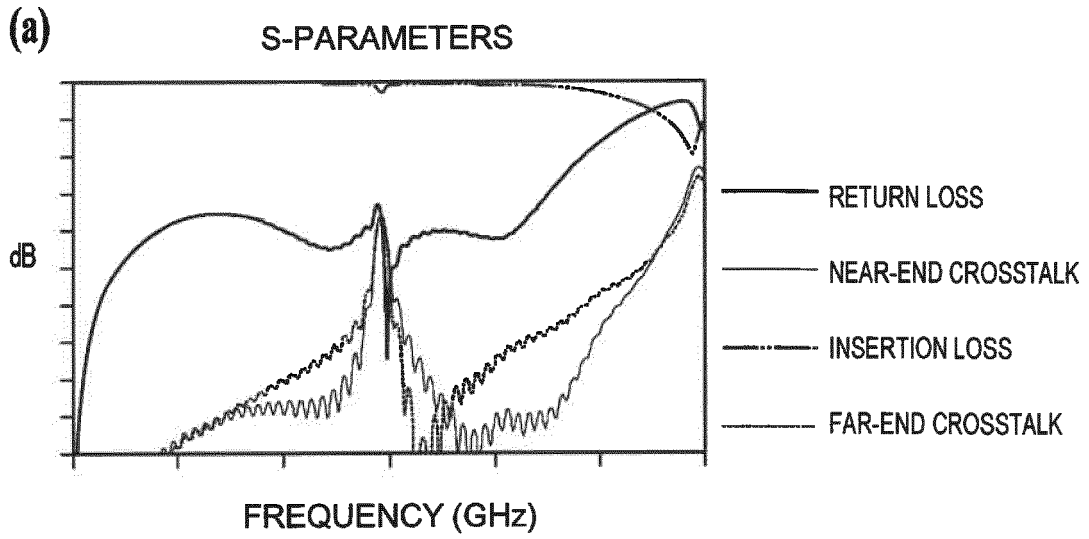

[Figure 4]

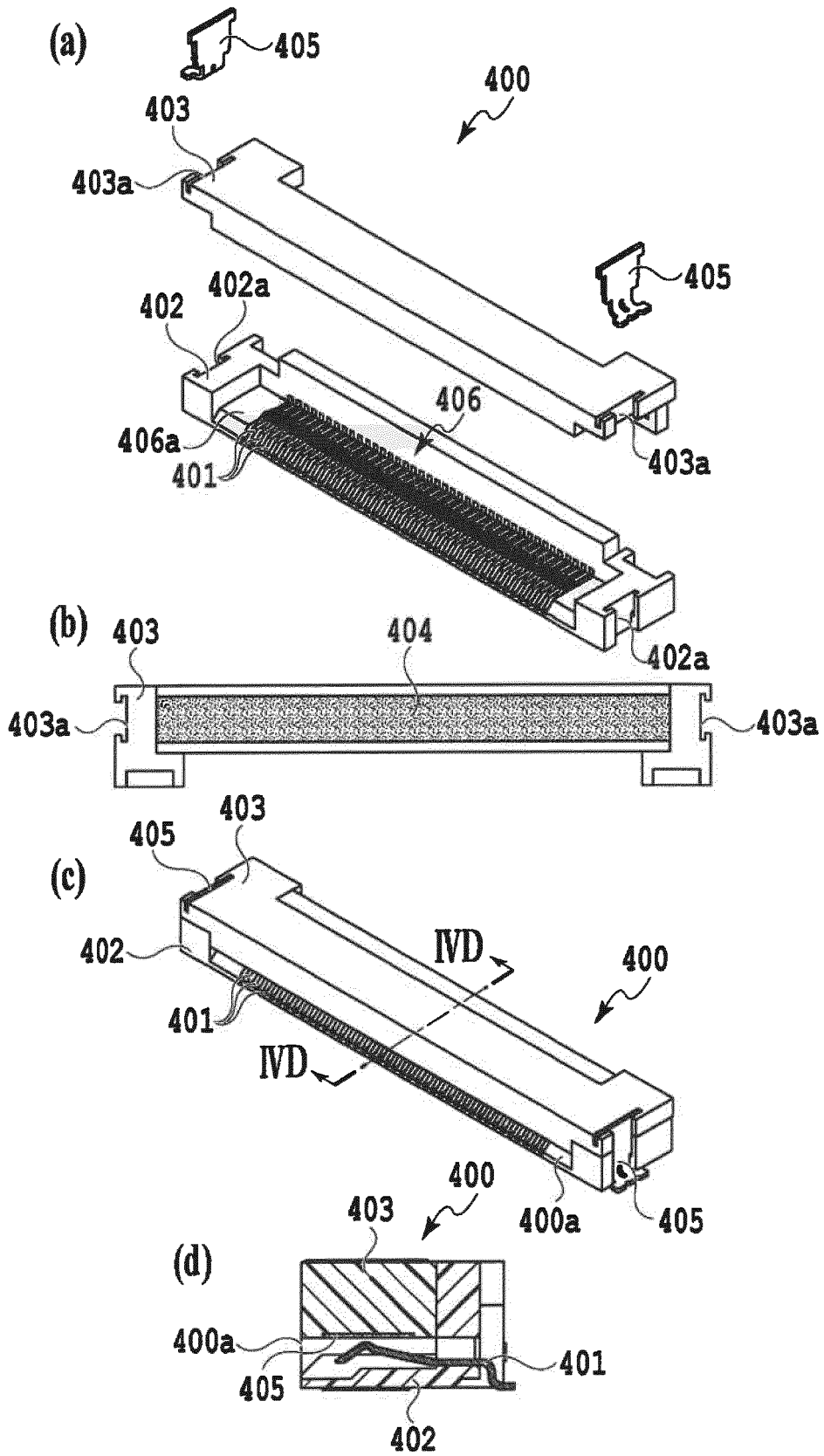

[Figure 5]

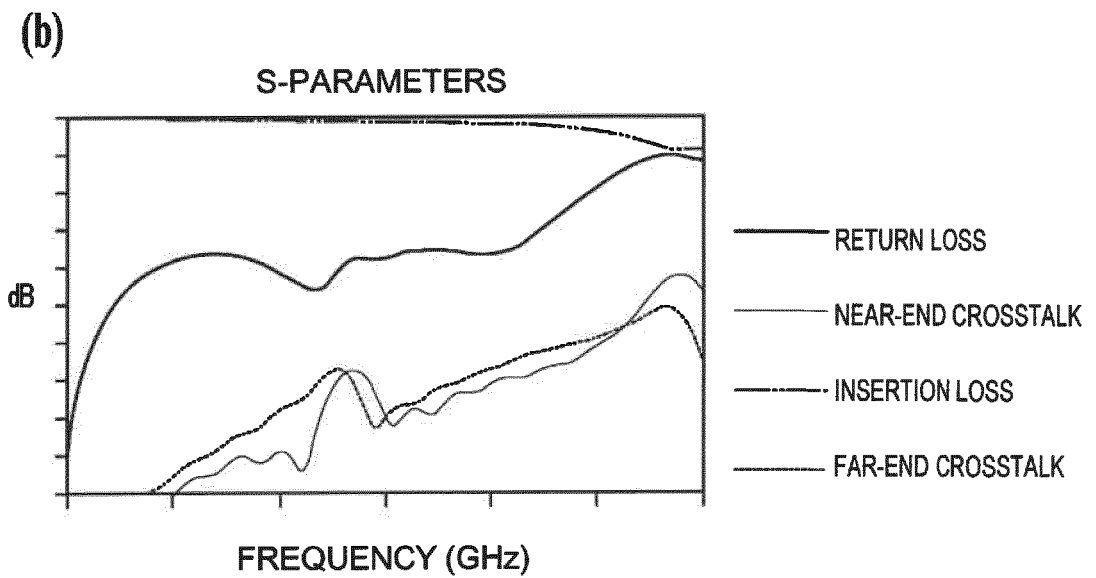
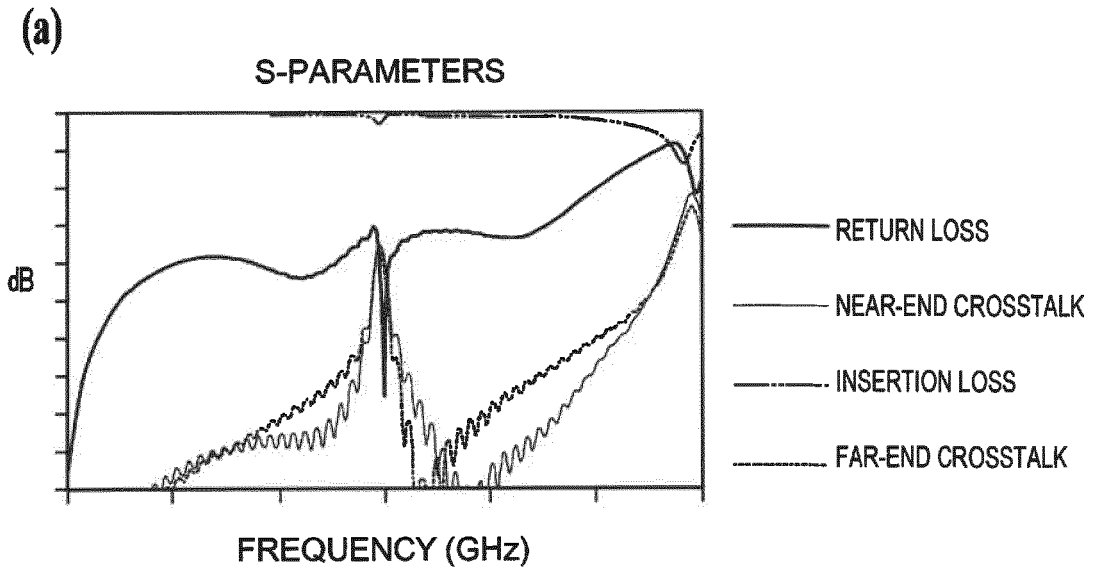

[Figure 6]

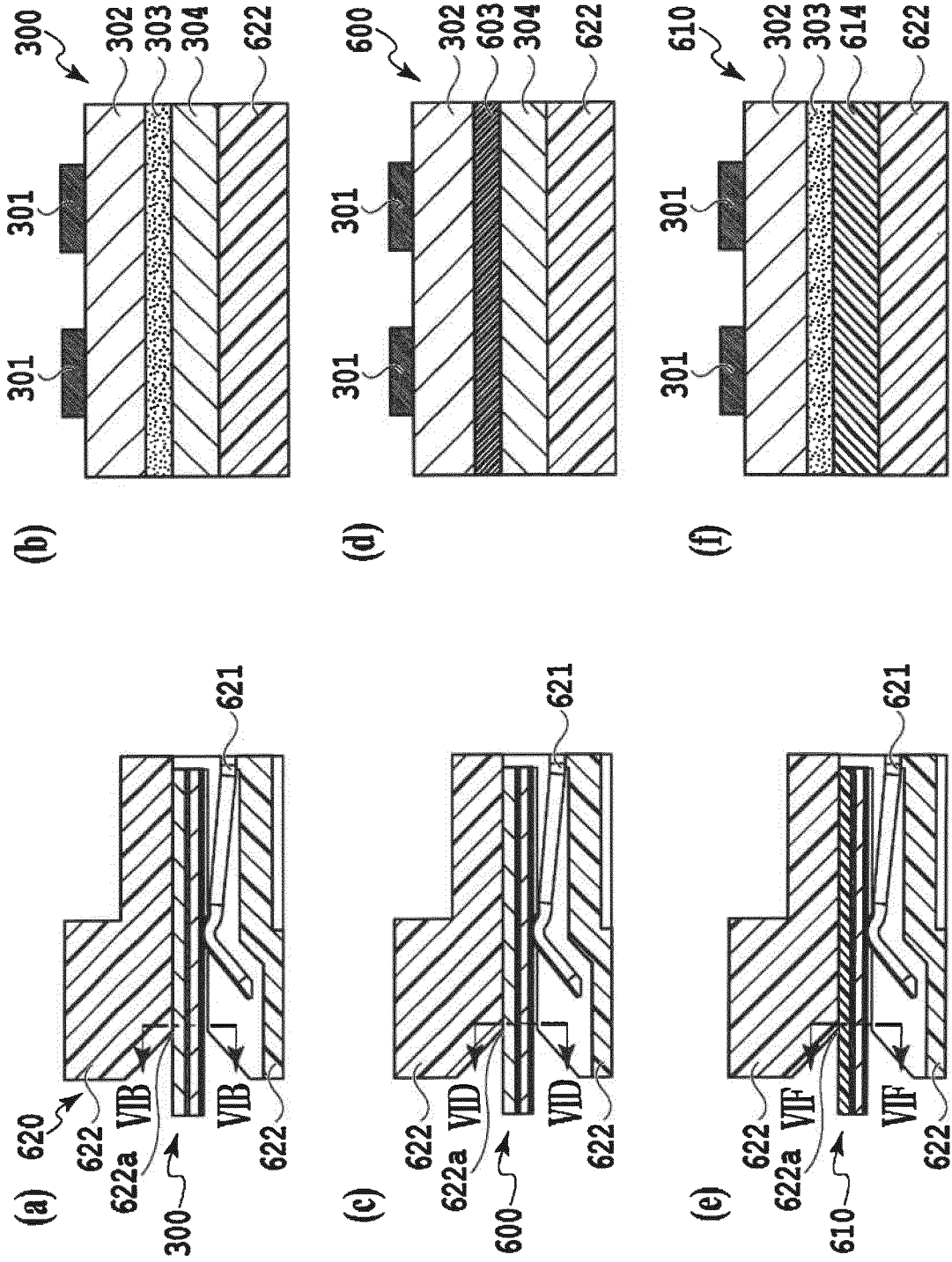

[Figure 7]

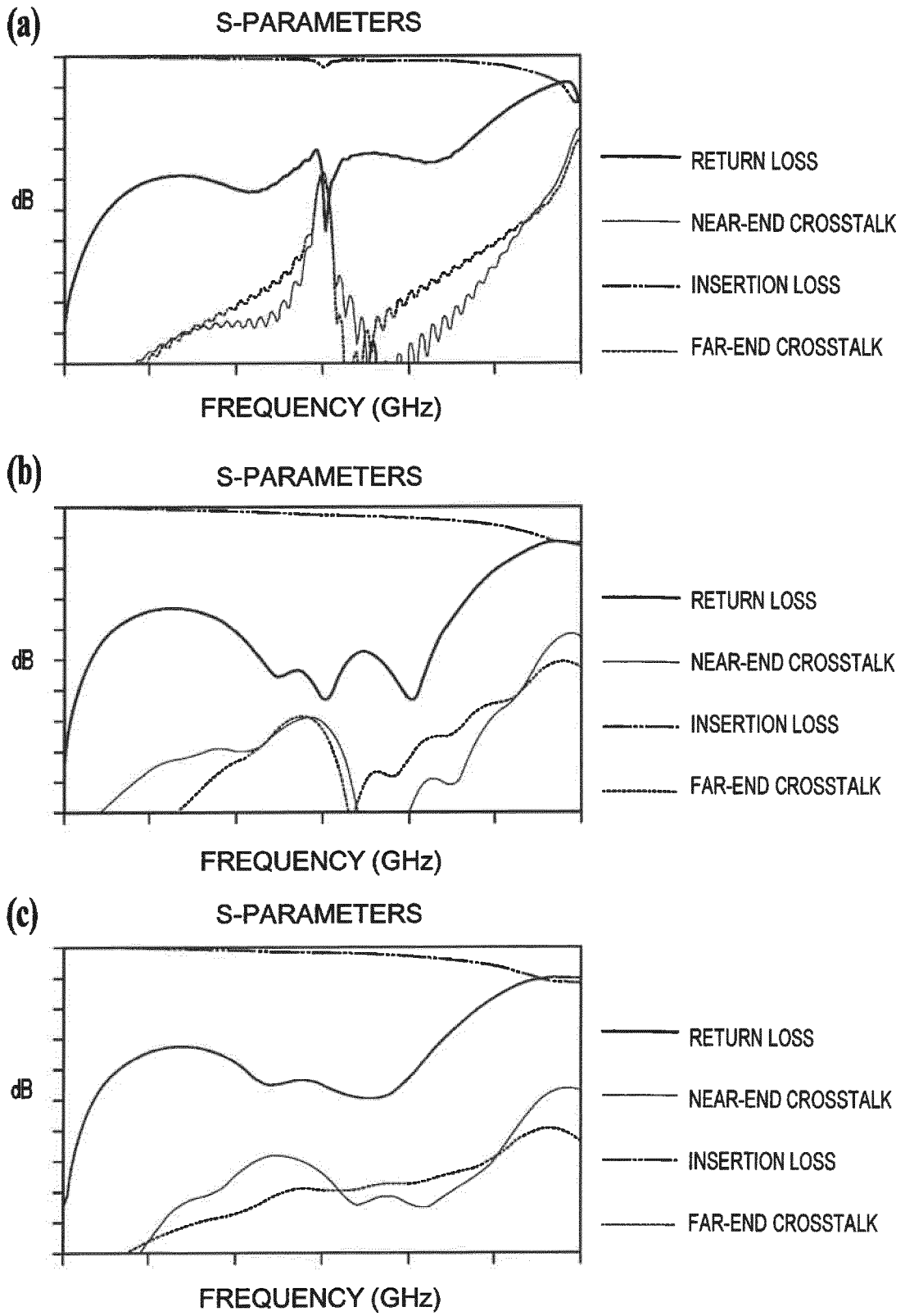

[Figure 8]

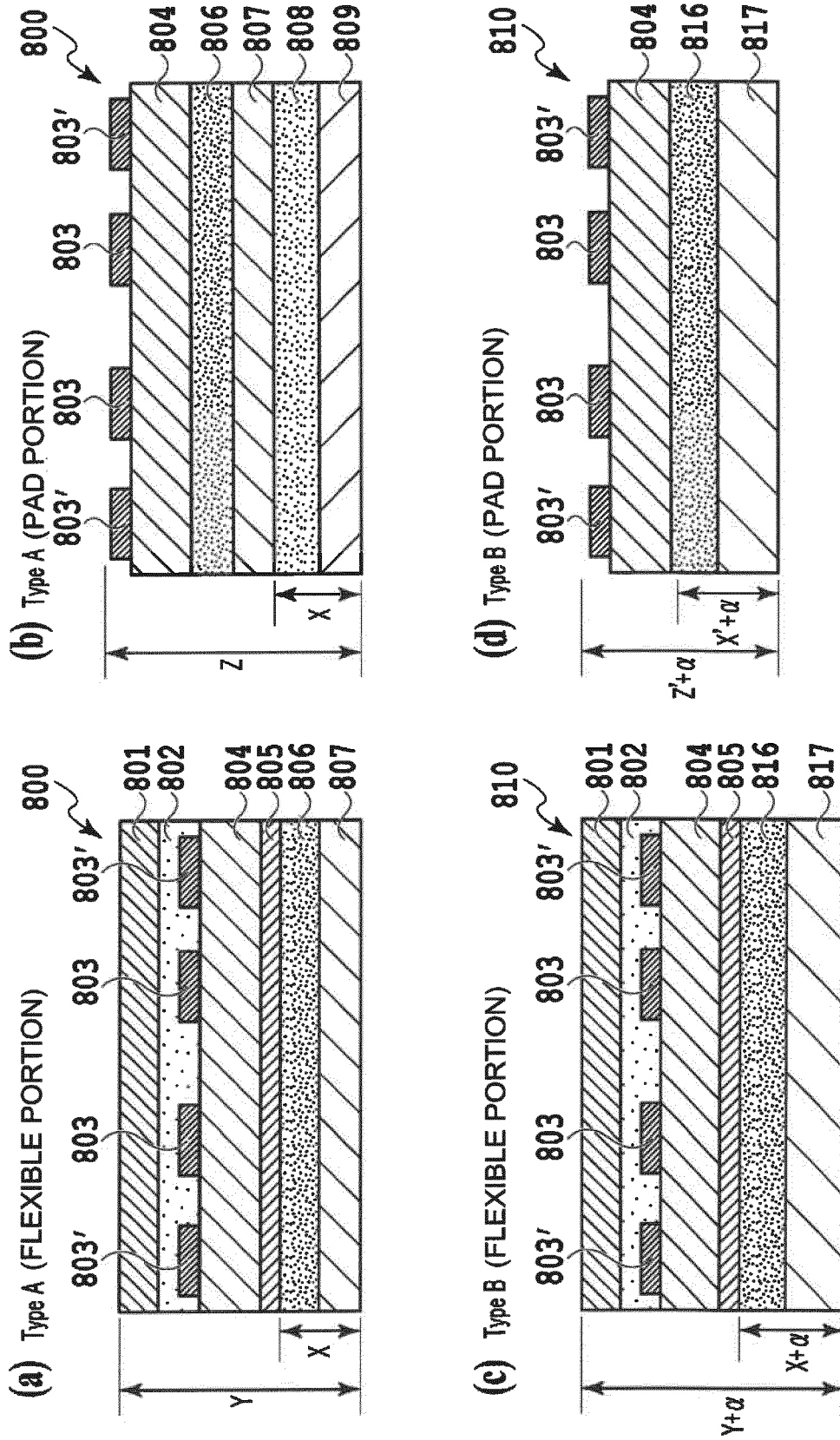

[Figure 9]

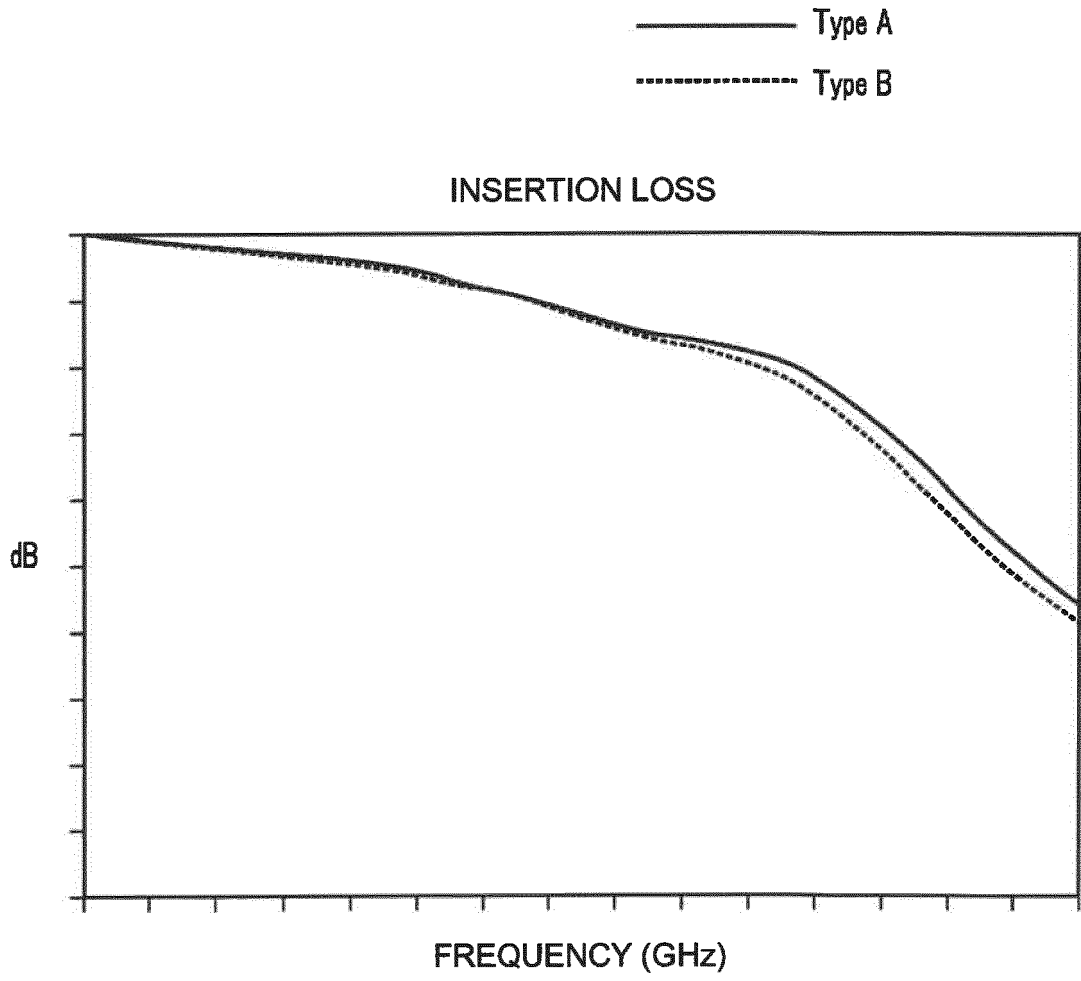

[Figure 10]

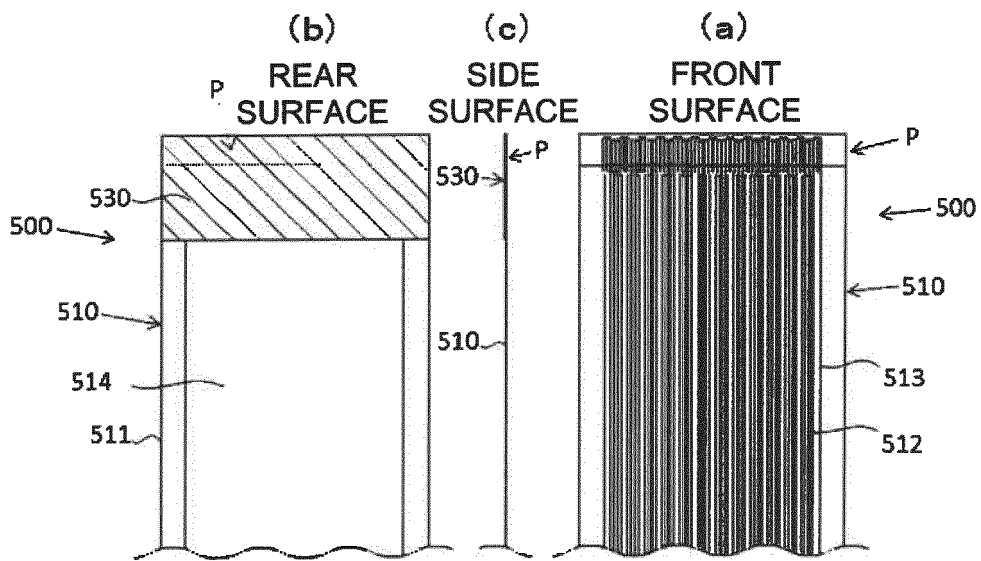

[Figure 11]

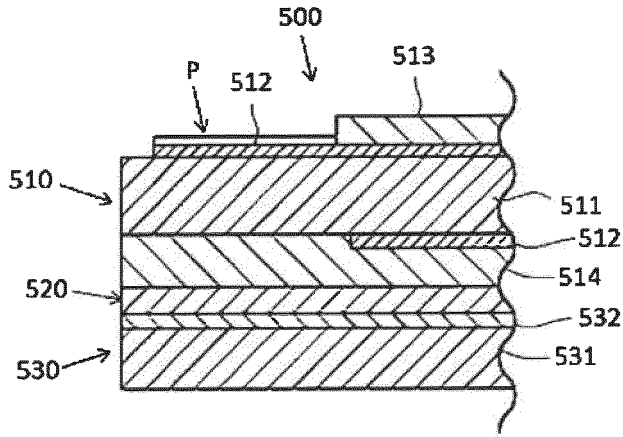

[Figure 12]

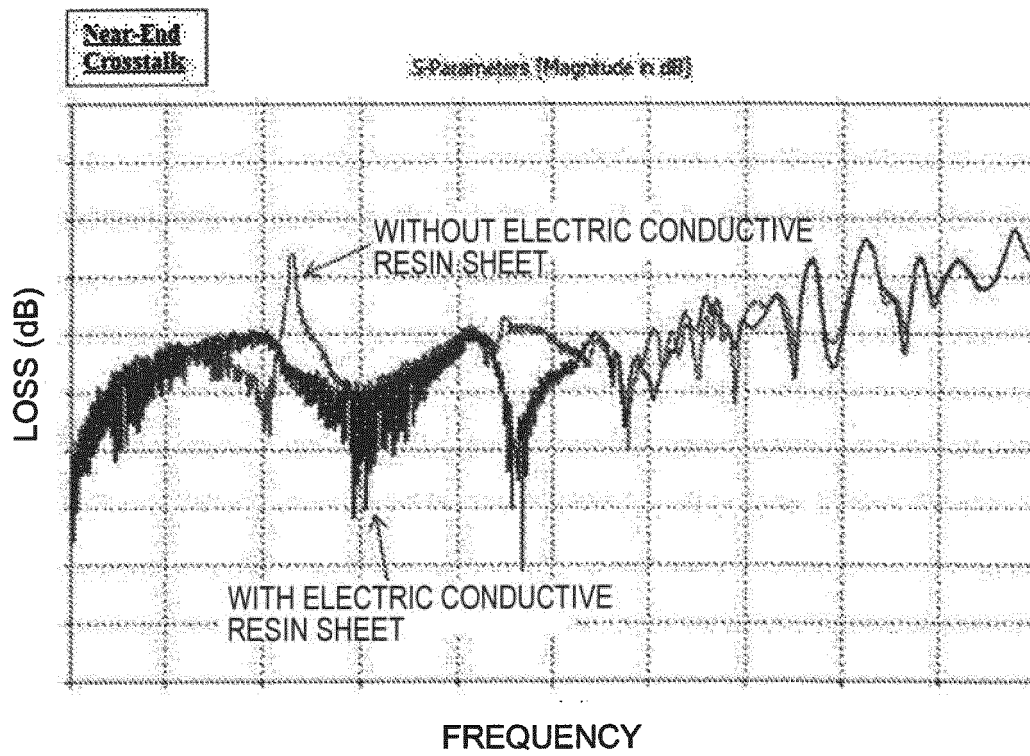

INTERNATIONAL SEARCH REPORT

International application No.

PCT/JP2017/020593

5	A. CLASSIFICATION OF SUBJECT MATTER H01R13/6474(2011.01)i, H01R12/78(2011.01)i, H01R12/89(2011.01)i		
	According to International Patent Classification (IPC) or to both national classification and IPC		
10	B. FIELDS SEARCHED Minimum documentation searched (classification system followed by classification symbols) H01R13/6474, H01R12/77, H01R12/89		
15	Documentation searched other than minimum documentation to the extent that such documents are included in the fields searched Jitsuyo Shinan Koho 1922-1996 Jitsuyo Shinan Toroku Koho 1996-2017 Kokai Jitsuyo Shinan Koho 1971-2017 Toroku Jitsuyo Shinan Koho 1994-2017		
	Electronic data base consulted during the international search (name of data base and, where practicable, search terms used)		
20	C. DOCUMENTS CONSIDERED TO BE RELEVANT		
	Category*	Citation of document, with indication, where appropriate, of the relevant passages	
		Relevant to claim No.	
25	A	JP 2008-251485 A (Fujitsu Component Ltd.), 16 October 2008 (16.10.2008), (Family: none)	1-11
30	A	JP 06-013122 A (Fujikura Ltd.), 21 January 1994 (21.01.1994), & US 5387124 A & EP 567394 A2	1-11
35	A	JP 2008-545249 A (Amphenol Corp.), 11 December 2008 (11.12.2008), & US 2007/0042639 A1 & WO 2007/005597 A2 & CN 101258649 A	1-11
40	A	JP 2008-300129 A (Yazaki Corp.), 11 December 2008 (11.12.2008), (Family: none)	1-11
45	<input checked="" type="checkbox"/> Further documents are listed in the continuation of Box C. <input type="checkbox"/> See patent family annex.		
	* Special categories of cited documents:	"T" later document published after the international filing date or priority date and not in conflict with the application but cited to understand the principle or theory underlying the invention	
	"A" document defining the general state of the art which is not considered to be of particular relevance	"X" document of particular relevance; the claimed invention cannot be considered novel or cannot be considered to involve an inventive step when the document is taken alone	
	"E" earlier application or patent but published on or after the international filing date	"Y" document of particular relevance; the claimed invention cannot be considered to involve an inventive step when the document is combined with one or more other such documents, such combination being obvious to a person skilled in the art	
	"L" document which may throw doubts on priority claim(s) or which is cited to establish the publication date of another citation or other special reason (as specified)	"&" document member of the same patent family	
	"O" document referring to an oral disclosure, use, exhibition or other means		
	"P" document published prior to the international filing date but later than the priority date claimed		
50	Date of the actual completion of the international search 02 August 2017 (02.08.17)	Date of mailing of the international search report 15 August 2017 (15.08.17)	
55	Name and mailing address of the ISA/ Japan Patent Office 3-4-3, Kasumigaseki, Chiyoda-ku, Tokyo 100-8915, Japan	Authorized officer Telephone No.	

Form PCT/ISA/210 (second sheet) (January 2015)

INTERNATIONAL SEARCH REPORT

International application No.
PCT/JP2017/020593

5

C (Continuation). DOCUMENTS CONSIDERED TO BE RELEVANT

10

15

20

25

30

35

40

45

50

55

Category*	Citation of document, with indication, where appropriate, of the relevant passages	Relevant to claim No.
A	JP 2007-109420 A (Taiko Denki Co., Ltd.), 26 April 2007 (26.04.2007), (Family: none)	1-11
A	JP 2008-218252 A (Autonetworks Technologies, Ltd.), 18 September 2008 (18.09.2008), (Family: none)	1-11

Form PCT/ISA/210 (continuation of second sheet) (January 2015)

REFERENCES CITED IN THE DESCRIPTION

This list of references cited by the applicant is for the reader's convenience only. It does not form part of the European patent document. Even though great care has been taken in compiling the references, errors or omissions cannot be excluded and the EPO disclaims all liability in this regard.

Patent documents cited in the description

- JP 2009272256 A [0005]
- JP 2002216873 A [0005]