



(11) **EP 3 511 607 A1**

(12) **EUROPEAN PATENT APPLICATION**
published in accordance with Art. 153(4) EPC

(43) Date of publication:
17.07.2019 Bulletin 2019/29

(51) Int Cl.:
F21S 8/04 ^(2006.01) **F21V 17/16** ^(2006.01)
F21V 17/12 ^(2006.01) **F21V 23/06** ^(2006.01)
F21V 21/02 ^(2006.01)

(21) Application number: **17847916.8**

(22) Date of filing: **28.03.2017**

(86) International application number:
PCT/CN2017/078359

(87) International publication number:
WO 2018/045741 (15.03.2018 Gazette 2018/11)

(84) Designated Contracting States:
AL AT BE BG CH CY CZ DE DK EE ES FI FR GB GR HR HU IE IS IT LI LT LU LV MC MK MT NL NO PL PT RO RS SE SI SK SM TR
Designated Extension States:
BA ME
Designated Validation States:
MA MD

(72) Inventors:
• **REN, Jinshan**
Qingdao Shandong 266101 (CN)
• **WANG, Deye**
Qingdao Shandong 266101 (CN)
• **LIU, Daping**
Qingdao Shandong 266101 (CN)

(30) Priority: **06.09.2016 CN 201610805092**

(71) Applicants:
• **Beijing Xiaomi Mobile Software Co., Ltd.**
Beijing 100085 (CN)
• **Qingdao Yeelink Information Technology Co., Ltd.**
Qingdao, Shandong 266101 (CN)

(74) Representative: **dompatent von Kreisler Selting Werner - Partnerschaft von Patent- und Rechtsanwälten mbB**
Deichmannhaus am Dom
Bahnhofsvorplatz 1
50667 Köln (DE)

(54) **CEILING LAMP STRUCTURE**

(57) The present disclosure relates to a ceiling lamp structure (100), comprising: a lamp top tray (11); a lamp body (12) disposed on the lamp top tray (11); and an elastic latch module (13) disposed on the lamp body (12), wherein the lamp top tray (11) comprises a hook portion (111) disposed on a circumferential side wall of the lamp top tray (11) and configured to mate with the elastic latch module (13), and wherein, when the lamp body (12) is assembled with the lamp top tray (11), the elastic latch module (13) is compressed by an external force, to make the lamp body (12) and the lamp top tray (11) be docked, after the lamp body (12) and the lamp top tray (11) are assembled in place, the external force on the elastic latch module (13) disappears, and the elastic latch module (13) is restored under an elastic force, to mate with the hook portion (11) to fix a connection. The present disclosure provides a ceiling lamp structure that can be quickly installed and disassembled, which is convenient for disassembly by the user, and which brings great convenience to the user, so that the user can easily complete the assembly and disassembly of the ceiling lamp structure.

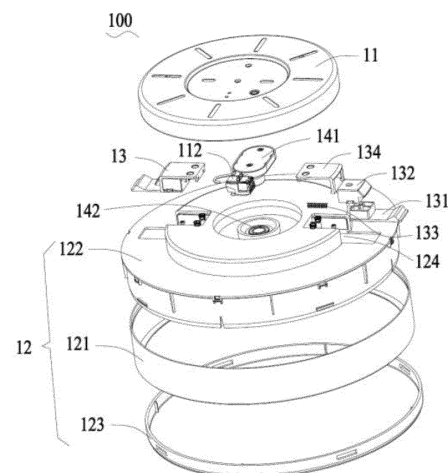

FIG. 1

EP 3 511 607 A1

Description

[0001] This application is based upon and claims priority to Chinese Patent Application No. CN201610805092.X, filed on September. 6, 2016, the entire content of which is incorporated herein by reference.

TECHNICAL FIELD

[0002] The present disclosure relates to the field of lighting equipment, and particularly to a ceiling lamp structure that can be quickly installed and disassembled.

BACKGROUND

[0003] The ceiling lamp is a type of lighting equipment, when installed, the bottom of which is completely attached to the ceiling, so it is called a ceiling lamp. The light source of a ceiling lamp may be an ordinary white light bulb, a fluorescent lamp, a high-intensity gas discharge lamp, a tungsten halogen lamp, an LED, and the like. At present, ceiling lamps, which are the most popular on the market, are lamps that are frequently adopted in various places such as homes, offices and entertainment venues.

[0004] The lamp top tray of the usual ceiling lamp is connected to the lamp body by manual bayonet lock, screwing or screw connection. However, these manners are complicated and time-consuming in installation and disassembly, and even need the cooperation of two people, which is very inconvenient to users.

SUMMARY

[0005] In view of this, the present disclosure proposes a ceiling lamp structure that can be quickly installed and disassembled to solve the above technical problems.

[0006] In order to achieve the above object, the technical solutions adopted by the present disclosure are:

According to an aspect of an embodiment of the present disclosure, a ceiling lamp structure is provided, including: a lamp body disposed on the lamp top tray; and an elastic latch module disposed on the lamp body, wherein the lamp top tray includes a hook portion disposed on a circumferential side wall of the lamp top tray and configured to mate with the elastic latch module, and wherein, when the lamp body is assembled with the lamp top tray, the elastic latch module is compressed by an external force, to make the lamp body and the lamp top tray be docked, after the lamp body and the lamp top tray are assembled in place, the external force on the elastic latch module disappears, and the elastic latch module is restored under an elastic force, to mate with the hook portion to fix a connection.

[0007] Optionally, the lamp body includes: a lamp housing; a lamp panel located in the lamp housing; and a lamp cover mounted to the lamp panel or the lamp housing, and

5 wherein the lamp cover is disposed on a side of the lamp panel that is opposite to the lamp top tray, the elastic latch module is disposed on a side of the lamp panel that faces the lamp top tray, and the lamp panel is provided with a guide slot for accommodating the elastic latch module.

10 **[0008]** Optionally, the elastic latch module includes: a pressing member; a latching member fixed to the pressing member; an elastic member connected to the pressing member and the lamp panel respectively; and a latch-fixing cover covering above the guide slot, wherein the pressing member and the latching member are restricted to slide in the guide slot.

15 **[0009]** Optionally, the pressing member includes: a pressing body; and a pressing portion provided at an end portion of the pressing body, wherein the latching member is located on the pressing body, and wherein, after the lamp body is mounted on the lamp top tray, the pressing portion is located outside the lamp top tray, and the latching member is located in the lamp top tray.

20 **[0010]** Optionally, an external side of the latching member includes a reversed spine configured to mate with the hook portion.

25 **[0011]** Optionally, the hook portion is formed by inwardly turning an end of the side wall of the lamp top tray that is close the lamp body.

30 **[0012]** Optionally, the hook portion is a slot hole formed in the circumferential side wall of the lamp top tray.

35 **[0013]** Optionally, it further includes: a connector assembly disposed between the lamp top tray and the lamp body, wherein the connector assembly includes: a first connector disposed in the lamp top tray, and a second connector disposed in the lamp body.

40 **[0014]** Optionally, the first connector is a coupler module, the second connector is a circular coupler guide slot, and the coupler module includes a circular connection portion configured to mate with the circular coupler guide slot, and

45 wherein elastic flake contacts are provided in both the circular connection portion and the circular coupler guide slot to mate with each other for electrical connection.

50 **[0015]** Optionally, the first connector is a circular coupler guide slot, the second connector is a coupler module, and the coupler module includes a circular connection portion configured to mate with the circular coupler guide slot, and

55 wherein elastic flake contacts are provided in both the circular connection portion and the circular coupler guide slot to mate with each other for electrical connection.

[0016] The technical solutions provided by the embodiments of the present disclosure may include the following beneficial effects: the present disclosure provides a ceiling lamp structure that can be quickly installed and disassembled. The elastic latch module of the present

disclosure can realize that the assembly between the lamp body and the lamp top tray can be completed only by pushing up the lamp body, and that the disassembly between the lamp body and the lamp top tray can be completed only by pressing the elastic latch module by one operation, which is convenient for disassembly by the user, and which brings great convenience to the user, so that the user can easily complete the assembly and disassembly of the ceiling lamp structure.

[0017] It shall be understood that the above general description and the following detailed description are merely exemplary and explanatory, which cannot limit the present disclosure.

BRIEF DESCRIPTION OF THE DRAWINGS

[0018] The accompanying drawings, which are incorporated in and constitute a part of this specification, illustrate embodiments consistent with the present disclosure and, together with the description, serve to explain the principles of the present disclosure.

FIG. 1 is an exploded perspective view of a ceiling lamp structure shown according to an exemplary embodiment;

FIG. 2 is a schematic structural view of a lamp top tray in a ceiling lamp structure shown according to an exemplary embodiment;

FIG. 3 is a schematic structural view of a hook portion of a lamp top tray in a ceiling lamp structure shown according to an exemplary embodiment;

FIG. 4 is a schematic structural view of a hook portion of a lamp top tray in a ceiling lamp structure shown according to another exemplary embodiment;

FIG. 5 is a schematic structural view of a lamp body in a ceiling lamp structure shown according to an exemplary embodiment;

FIG. 6 is a schematic cross-sectional view of a lamp top tray and a lamp body in a ceiling lamp structure before assembled showing according to an exemplary embodiment;

FIG. 7 is a schematic structural view of a lamp top tray and a lamp body in a ceiling lamp structure after assembled showing according to an exemplary embodiment; and

FIG. 8 is a schematic cross-sectional view of a lamp top tray and a lamp body in a ceiling lamp structure when being disassembled showing according to an exemplary embodiment.

DETAILED DESCRIPTION

[0019] The present disclosure will be described in detail below in conjunction with the embodiments shown in the drawings. However, the embodiments do not limit the disclosure, and the changes on structure, method or function made by those skilled in the art according to the embodiments are all included in the protection scope of

the present disclosure.

[0020] The terms used in the present disclosure are for the purpose of describing particular embodiments only, and are not intended to limit the disclosure. The singular forms "a" and "the" as used in the present disclosure and the appended claims intend to include the plural forms thereof, unless the context clearly indicates other meanings. It should further be understood that the term "and/or" as used herein refers to and encompasses any and all possible combinations of one or more of the associated listed items.

[0021] As shown in FIG. 1, FIG. 1 is an exploded perspective view of a ceiling lamp structure shown according to an exemplary embodiment. The ceiling lamp structure 100 of the present disclosure breaks the conventional installation mode, does not need to be deliberately docked during installation, can be assembled by pushing up at any angle, and can be disassembled conveniently, so that ordinary users can quickly install it by themselves, which is quick and convenient, and greatly reduces the difficulty of installing the ceiling lamp structure 100.

[0022] The ceiling lamp structure 100 of the present disclosure includes: a lamp top tray 11; a lamp body 12 mounted to the lamp top tray 11; and an elastic latch module 13 disposed on the lamp body 12. When the ceiling lamp structure 100 is assembled, the lamp top tray 11 is fixed to a predetermined position in the house by screws, expansion screws, or the like in advance, and then the lamp body 12 is assembled to the lamp top tray 11, such that the assembly of the ceiling lamp structure 100 is completed. The respective components of the lamp body 12 can be pre-assembled the assembly with the lamp top tray 11 in advance. The present disclosure utilizes the elastic latch module 13 to realize that the lamp body 12 can be quick assembled with the lamp top tray 11.

[0023] As shown in FIG. 5 to FIG. 8, the lamp top tray 11 further includes: a hook portion 111, disposed on the circumferential side wall of the lamp top tray, and configured to mate with the elastic latch module 13. When the lamp body 12 is being assembled with the lamp top tray 11, the elastic latch module 13 is compressed by an external force to make the lamp body 12 and the lamp top tray 11 be docked. After the lamp body 12 and the lamp top tray 11 are assembled in place, the external force on the elastic latch module 13 disappears, and the elastic latch module 13 is restored under the elastic force, to mate with the hook portion 111 to fix the connection. Specifically, when the lamp body 12 and the lamp top tray 11 are assembled, the circumferential side wall of the lamp top tray 11 acts on the elastic latch module 13 to apply force on the elastic latch module 13, so as to compress the lamp body 12 to be assembled with the lamp top tray 11. After the elastic latch module 13 fully inserts into the hook portion 111, the external force acting on the elastic latch module 13 disappears. At this time, the elastic latch module 13 returns to the initial state under the elastic restoring force, then directly mates with the

hook portion 111 to fix the latch, that is, to realize that the lamp body 12 can be assembled with the lamp top tray 11.

[0024] In a preferred embodiment of the present disclosure, the lamp body 12 is provided with two elastic latch modules 13 disposed on two sides of the lamp body 12 that are in a central symmetry. The two elastic latch modules 13 can realize the effect of the balance of the assembly between the lamp body 12 and the lamp top tray 11, and at the same time, the lamp body 12 can be directly pushed up to be assembled with the lamp top tray 11 without any other auxiliary assembly action, so that the fixing effect is good and the operation is simple. For a larger or heavier lamp body 12, more elastic latch modules 13 can be adopted to ensure the reliability of assembly between the lamp body 12 and the lamp top tray 11. Of course, in another embodiment of the present disclosure, it can adopt only one elastic latch module 13, the side of the lamp body 12 opposite to the elastic latch module 13 can be provided with a hook, a sticking sheet, etc., to be connected with the lamp top tray 11 in advance, and then the elastic latch module 13 is adopted to realize a fixed connection.

[0025] As shown in FIG. 1 and FIG. 5, the lamp body 12 includes: a lamp housing 121; a lamp panel 122 located in the lamp housing 121; and a lamp cover 123 mounted to the lamp panel 122 or the lamp housing 121. The lamp housing 121 is fixed to the lamp panel 122. The lamp cover 123 can be fixed to the lamp panel 122 or fixed to the lamp housing 121 according to different designs. Preferably, the circumferential side surface of the lamp cover 123 is coincident with the circumferential side surface of the lamp housing 121, so as to prevent dust from falling into the lamp cover 123, thus the dust can be effectively prevented. The dustproof level may be IP50, so as to prevent harmful dust accumulation, to create a relatively closed using environment, thus to extend the life of the lamp.

[0026] The lamp body 12 further includes a light source (not shown) disposed on the lamp panel 122. The light source and the elastic latch module 13 are disposed on two sides of the lamp panel 122. The light cover 123 and the light source are located on the same side of the lamp panel 122. The light cover 123 is disposed on the light source to protect the light source and aid diffusion of the light source. The lamp cover 123 is disposed on a side of the lamp panel 122 that is opposite to the lamp top tray 11, and the elastic latch module 13 is disposed on a side of the lamp panel 122 that faces the lamp top tray 11. The lamp panel 122 is provided with a guide slot 124 for accommodating the elastic latch module 13. The elastic latch module 13 is subjected to an external force, and it can slide in the guide slot 124.

[0027] The elastic latch module 13 of the present disclosure includes: a pressing member 131; a latching member 132 fixed to the pressing member 131; an elastic member 133 connected to the pressing member 131 and the lamp panel 122 respectively; and a latch-fixing cover

134 covering above the guide slot 124. The pressing member 131 and the latching member 132 are restricted to slide in the guide slot 124. In an embodiment of the present disclosure, a slide slot (not shown) is disposed in the guide slot 124, and both sides of the pressing member 131 are restricted in the slide slot, so that the pressing member 131 is restricted to move in one direction. In still another embodiment of the present disclosure, the pressing member is provided with a slot hole, the longitudinal direction of the slot hole is consistent with a radial direction of the lamp body, a limit column is disposed in the guide slot. The pressing member mates on the limit column, so as to move along the slot hole.

[0028] Further, the pressing member 131 includes: a pressing body 1311; and a pressing portion 1312 provided at the end portion of the pressing body 1311. In the embodiment of the present disclosure, the pressing portion 1312 is located at the head end of the pressing body 1311, and the elastic member 133 is connected to the tail end of the pressing body 1311. Optionally, the elastic member 133 is a spring, and the axial direction of the spring is the same as the direction of motion of pressing member 131. The latching member 132 is located on the pressing body 1311. The pressing body 1311 has a larger size in the sliding direction than that of the latching member 132, and the pressing portion 1312 is away from the center of the lamp body 12 relative to the latching member 132. After the lamp body 12 is mounted on the lamp top tray 11, the pressing portion 1312 is located outside the lamp top tray 11, and the latching member 132 is located in the lamp top tray 11.

[0029] In an embodiment of the present disclosure, the external side of the latching member 132 includes a reversed spine configured to mate with the hook portion 111. The inverted spine includes: a guide slope 1321; and a positioning portion 1322 that mates with the hook portion 111 for fixing. When the lamp body 12 is mounting on the lamp top tray 11, the lamp top tray 11 acts on the guide slope 1321, at this time, the latching member 132 brings the pressing member 131 to compress inward, and the elastic member 133 is in a compressed state. The lamp top tray 11 may continue relatively sliding along the guide slope 1321 until it moves to the positioning portion 1322. Since the positioning portion 1322 is recessed relative to the guide slope 1321, the lamp top tray 11 no longer acts on the hook portion 111, at this time the elastic member 133 is restored to the initial state under its own property, then the inverted spine moves outward as well, that is, it can mate with the hook portion 111.

[0030] As shown in FIG. 1 to FIG. 3, in an embodiment of the present disclosure, the hook portion 111 is formed by inwardly turning the end of the side wall of the lamp top tray 11 that is close the lamp body 12, that is, the hook portion 111 is of a barbed shape on the circumferential side wall of the lamp top tray 11. When the lamp top tray 11 acts on the reversed spine, the hook portion 111 abuts against the guide slope 1321 of the reversed spine and slides along the guide slope 1321 until the

hook portion 111 and the positioning portion 1322 are mated.

[0031] As shown in FIG. 1, FIG. 2 and FIG. 4, in another embodiment of the present disclosure, the hook portion 111 is a slot hole formed in the circumferential side wall of the lamp top tray 11. As needed for assembly, a plurality of slot holes may be provided in the circumferential side wall of the lamp top tray 11, such that, when the lamp body 12 and the lamp top tray 11 is being assembled, no specific assembly position is needed. When the lamp top tray 11 acts on the reversed spine, the circumferential side wall of the lamp top tray 11 abuts against the guide slope 1321 of the reversed spine and slides along the guide slope 1321 until the reversed spine inserts the slot, then the mating between the hook portion 111 and the reversed spine is completed.

[0032] Further, the ceiling lamp structure 100 further includes: a connector assembly 14 disposed between the lamp top tray 11 and the lamp body 12. The connector assembly 14 includes: a first connector 141 disposed in the lamp top tray 11, and a second connector 142 disposed in the lamp body 12. The connector assembly 14 of the present disclosure can complete the electrical connection by docking the first connector 141 and the second connector 142 together. Such fitting is simple and requires no other operation, so it is suitable for the manner in which the lamp body 12 and the lamp top tray 11 of the present disclosure are assembled.

[0033] In an embodiment of the present disclosure, the first connector 141 is a coupler module, and the second connector 142 is a circular coupler guide slot. The coupler module includes a circular connection portion configured to mate with the circular coupler guide slot. Elastic flake contacts (not shown) are provided in both the circular connection portion and the circular coupler guide slot to mate with each other for electrical connection, by which, when the first connector 141 and the second connector 142 are docked to each other, the electrical connection is completed. In this embodiment, the design of the circular connector of the coupler and the circular coupler guide slot makes the lamp body 12 be able to be assembled with the lamp top tray 11 at any angle of 360 degrees, and be arbitrarily adjusted in the plane direction, and makes any shape (the regular shape or irregular shape) of the lamp cover 123 be able to be assembled quickly and adjusted for any angle after the assembly.

[0034] In other optional embodiments of the present disclosure, the first connector 141 is a circular coupler guide slot, and the second connector 142 is a coupler module. The coupler module includes a circular connection portion configured to mate with the circular coupler guide slot. Elastic flake contacts are provided in both the circular connection portion and the circular coupler guide slot to mate with each other for electrical connection. In this embodiment, the assembly manner and effect of the first connector 141 and the second connector 142 are the same as those of the above embodiment, except the position conversion, so the specific assembly effect of

the first connector 141 and the second connector 142 will not be repeated here.

[0035] As shown in FIG. 2, the lamp top tray 11 of the present disclosure is further provided with a wiring hole 112, an external wire quick connecting terminal 113, a screw hole 114 and an expansion screw hole 115. The external wire quick connecting terminal 113 is configured to be electrically connected to the coupler module. The external wire may penetrate into the lamp top tray 11 through the wiring hole 112, and realize the electrical connection by being inserted into external wire quick connecting terminal 113, the operation of which is simple. In this embodiment, at least two screw holes 114 are disposed on the lamp top tray 11. When two screw holes 114 are provided, the two screw holes 114 are located on the opposite sides of the coupler module. Preferably, the distance between the centers of the two screw holes 114 are ranged from 55 mm to 110mm, which can adapt the screw assembly manners in various situations, for example, assembly with such as the national standard 86 cassette, octagonal cassette, and so on. The number of the expansion screw holes 115 is at least two as well. When there are more the expansion screw holes 115, they can be evenly distributed on the lamp top tray 11. In the present disclosure, the lamp top tray 11 is provided with two kinds of connection holes (the screw holes 114 and the expansion screw holes 115) for the user to select and use, which increases the selectivity for the user, so that the ceiling lamp structure of the present disclosure can be suitable for ceilings of more situations.

[0036] The present disclosure provides a ceiling lamp structure that can be quickly installed and disassembled. The elastic latch module of the present disclosure can realize that the assembly between the lamp body and the lamp top tray can be completed only by pushing up the lamp body, and that the disassembly between the lamp body and the lamp top tray can be completed only by pressing the elastic latch module by one operation, which is convenient for disassembly by the user, and which brings great convenience to the user, so that the user can easily complete the assembly and disassembly of the ceiling lamp structure.

[0037] Other embodiments of the present disclosure will be readily thought of by those skilled in the art, after they consider the specification and practice the disclosure disclosed herein. The present application is intended to cover any variations, uses, or adaptations of the present disclosure, which comply with the general principles of the disclosure and include common sense or commonly-used technical means in the art that are not disclosed in the present disclosure. The specification and examples are regarded as illustrative only, and the true scope and spirit of the disclosure are defined by the claims of the present application.

[0038] It is to be understood that the disclosure is not limited to the detailed structures that have been described above and shown in the accompanying drawings. Instead, various variation and transformation can be per-

formed within the scope of the disclosure. The scope of the disclosure is defined only by the appended claims.

Claims

1. A ceiling lamp structure, comprising: a lamp top tray; a lamp body disposed on the lamp top tray; and an elastic latch module disposed on the lamp body, wherein the lamp top tray comprises a hook portion disposed on a circumferential side wall of the lamp top tray and configured to mate with the elastic latch module, and
wherein, when the lamp body is assembled with the lamp top tray, the elastic latch module is compressed by an external force, to make the lamp body and the lamp top tray be docked, after the lamp body and the lamp top tray are assembled in place, the external force on the elastic latch module disappears, and the elastic latch module is restored under an elastic force, to mate with the hook portion to fix a connection. 5
2. The ceiling lamp structure according to claim 1, wherein the lamp body comprises: a lamp housing; a lamp panel located in the lamp housing; and a lamp cover mounted to the lamp panel or the lamp housing, and
wherein the lamp cover is disposed on a side of the lamp panel that is opposite to the lamp top tray, the elastic latch module is disposed on a side of the lamp panel that faces the lamp top tray, and the lamp panel is provided with a guide slot for accommodating the elastic latch module. 10
3. The ceiling lamp structure according to claim 2, wherein the elastic latch module comprises: a pressing member; a latching member fixed to the pressing member; an elastic member connected to the pressing member and the lamp panel respectively; and a latch-fixing cover covering above the guide slot, wherein the pressing member and the latching member are restricted to slide in the guide slot. 15
4. The ceiling lamp structure according to claim 3, wherein the pressing member comprises: a pressing body; and a pressing portion provided at an end portion of the pressing body, wherein the latching member is located on the pressing body, and wherein, after the lamp body is mounted on the lamp top tray, the pressing portion is located outside the lamp top tray, and the latching member is located in the lamp top tray. 20
5. The ceiling lamp structure according to claim 4, wherein an external side of the latching member comprises a reversed spine configured to mate with the hook portion. 25
6. The ceiling lamp structure according to claim 5, wherein the hook portion is formed by inwardly turning an end of the side wall of the lamp top tray that is close the lamp body. 30
7. The ceiling lamp structure according to claim 5, wherein the hook portion is a slot hole formed in the circumferential side wall of the lamp top tray. 35
8. The ceiling lamp structure according to claim 1, further comprising: a connector assembly disposed between the lamp top tray and the lamp body, wherein the connector assembly comprises: a first connector disposed in the lamp top tray, and a second connector disposed in the lamp body. 40
9. The ceiling lamp structure according to claim 8, wherein the first connector is a coupler module, the second connector is a circular coupler guide slot, and the coupler module comprises a circular connection portion configured to mate with the circular coupler guide slot, and
wherein elastic flake contacts are provided in both the circular connection portion and the circular coupler guide slot to mate with each other for electrical connection. 45
10. The ceiling lamp structure according to claim 8, wherein the first connector is a circular coupler guide slot, the second connector is a coupler module, and the coupler module comprises a circular connection portion configured to mate with the circular coupler guide slot, and
wherein elastic flake contacts are provided in both the circular connection portion and the circular coupler guide slot to mate with each other for electrical connection. 50

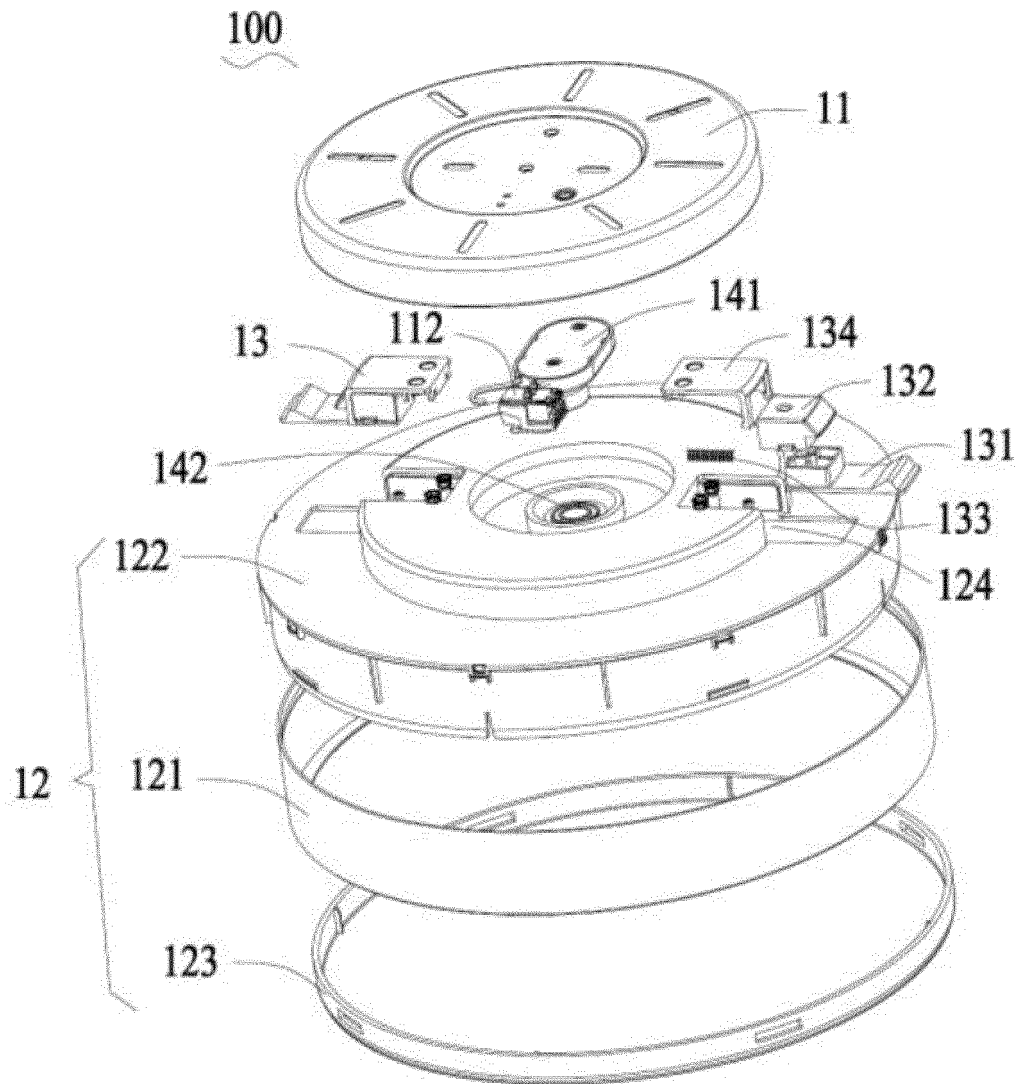

FIG. 1

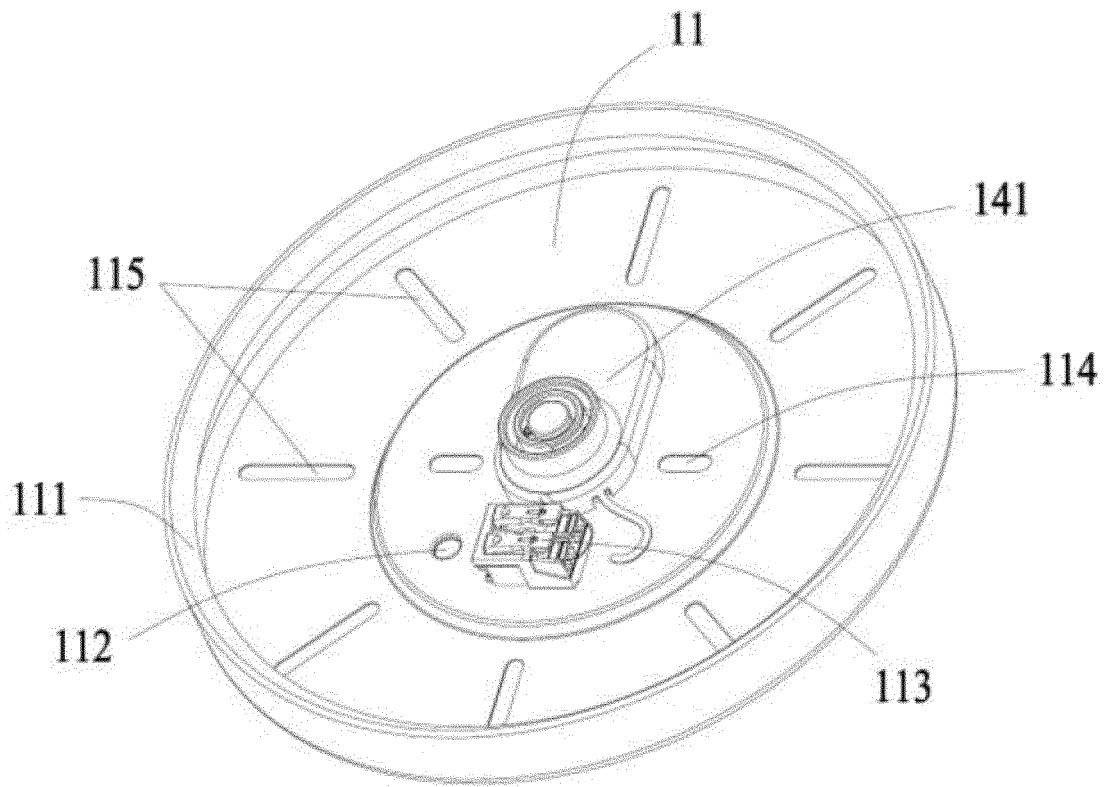

FIG. 2

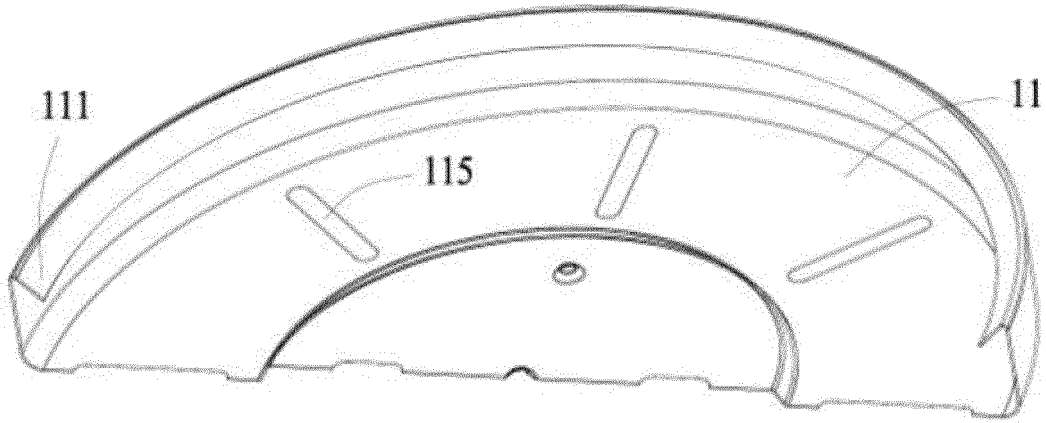

FIG. 3

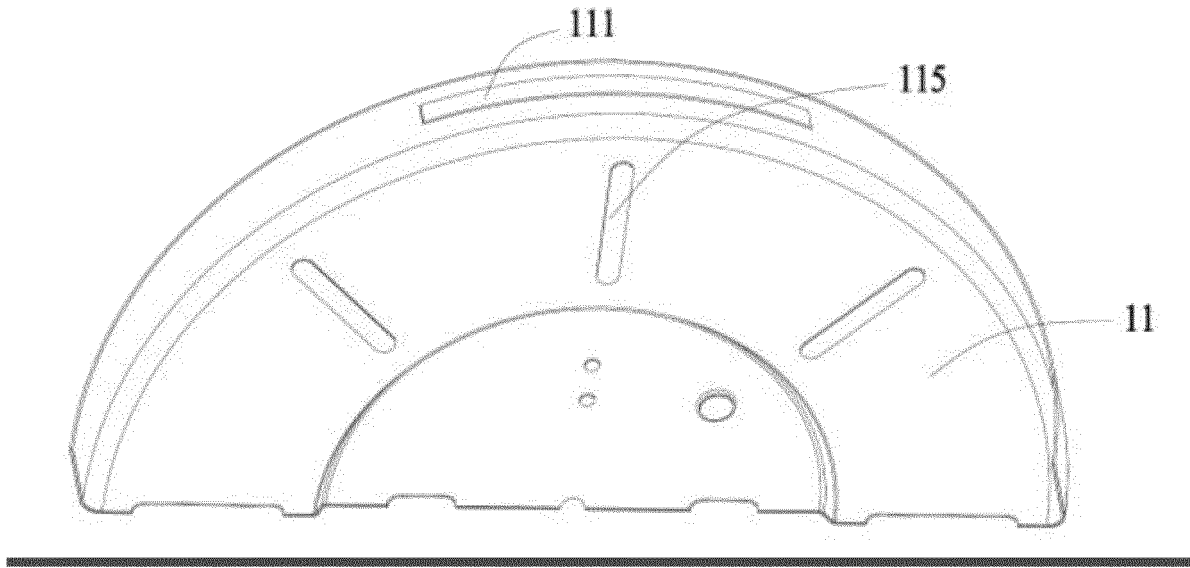

FIG. 4

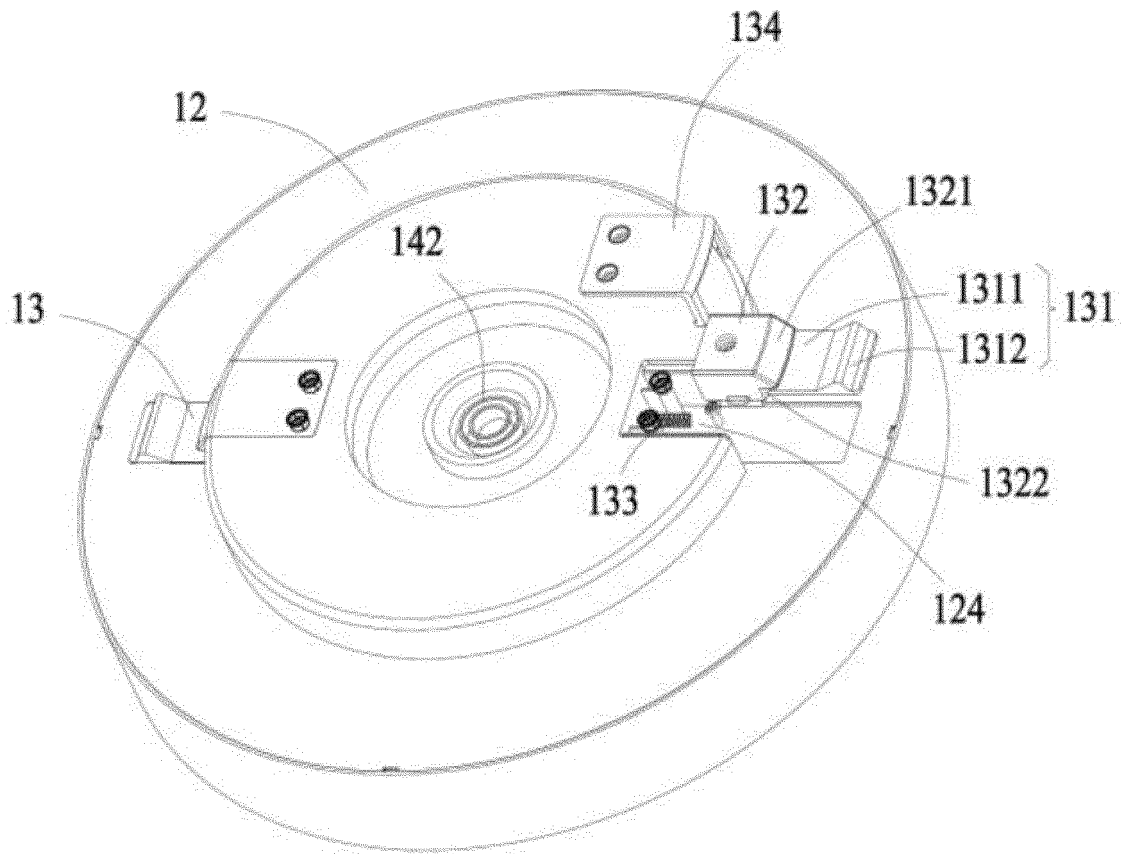

FIG. 5

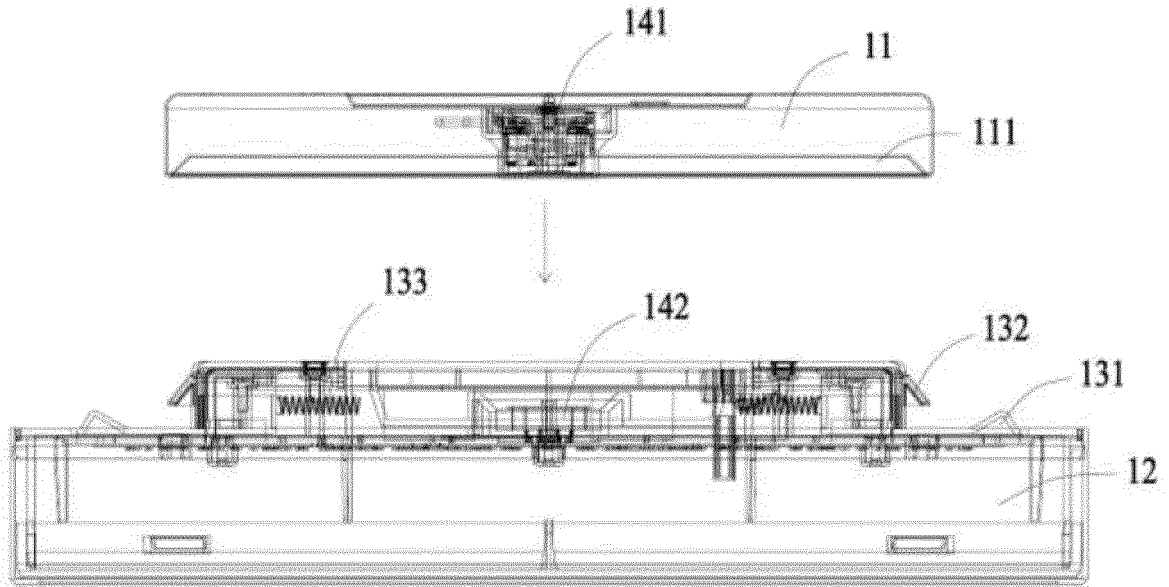

FIG. 6

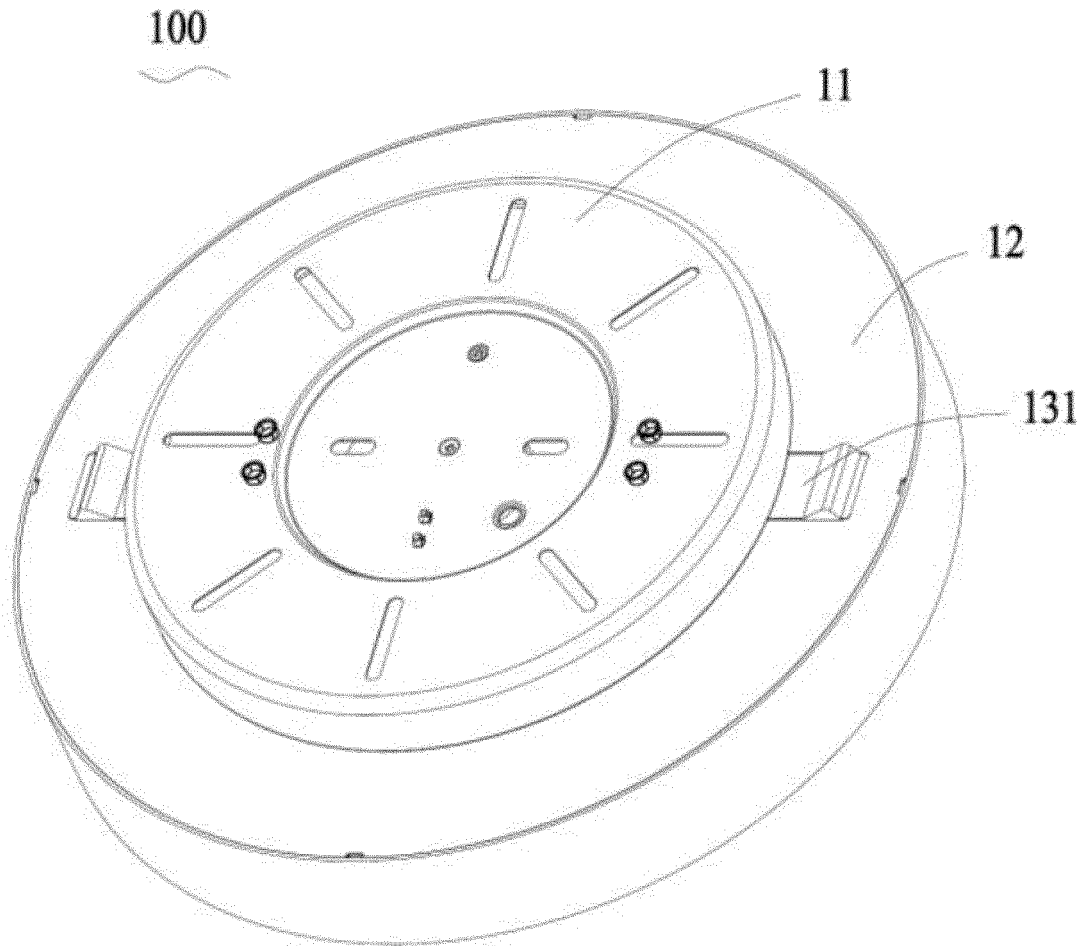

FIG. 7

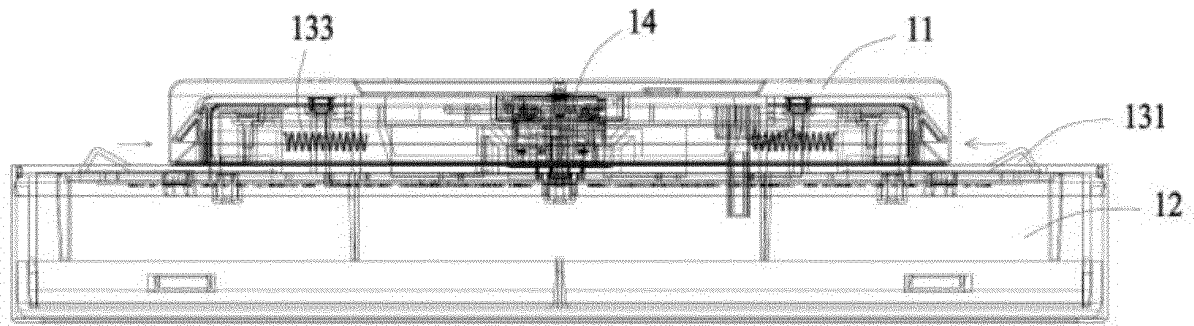

FIG. 8

INTERNATIONAL SEARCH REPORT

International application No.

PCT/CN2017/078359

5	A. CLASSIFICATION OF SUBJECT MATTER		
	F21S 8/04 (2006.01) i; F21V 17/16 (2006.01) i; F21V 17/12 (2006.01) i; F21V 23/06 (2006.01) i; F21V 21/02 (2006.01) i According to International Patent Classification (IPC) or to both national classification and IPC		
10	B. FIELDS SEARCHED		
	Minimum documentation searched (classification system followed by classification symbols) F21		
15	Documentation searched other than minimum documentation to the extent that such documents are included in the fields searched		
	Electronic data base consulted during the international search (name of data base and, where practicable, search terms used) CNABS, VEN, CNTXT: 吸顶灯, 屋顶, 天花, 吊顶, 卡, 扣, 钩, 槽, 凹, 孔, ceiling, light+, housetop, roof +, rooftop+, clamp+, hook+, channel+, concav+, hole+		
20	C. DOCUMENTS CONSIDERED TO BE RELEVANT		
	Category*	Citation of document, with indication, where appropriate, of the relevant passages	
		Relevant to claim No.	
25	PX	CN 205979444 U (BEIJING XIAOMI MOBILE SOFTWARE CO., LTD. et al.), 22 February 2017 (22.02.2017), claims 1-10, description, pages 3-5, and figures 1-8	1-10
	PX	CN 106151992 A BEIJING XIAOMI MOBILE SOFTWARE CO., LTD. et al.), 23 November 2016 (23.11.2016), claims 1-10, description, pages 3-5, and figures 1-8	1-10
	X	CN 205037267 U (CHEN, Jianneng), 17 February 2016 (17.02.2016), description, pages 2-4, and figures 1-5	1-10
30	X	CN 204665062 U (SHENZHEN EASTFIELD LIGHTING CO., LTD.), 23 September 2015 (23.09.2015), description, pages 2-3, and figures 1-5	1-10
	A	CN 103090330 A (HANGZHOU HONYAR UNITY OPTOELECTRONIC TECHNOLOGY CO., LTD. et al.), 08 May 2013 (08.05.2013), entire document	1-10
	A	CN 203336496 U (RICH BRAND INDUSTRIES LIMITED), 11 December 2013 (11.12.2013), entire document	1-10
35	<input type="checkbox"/> Further documents are listed in the continuation of Box C. <input checked="" type="checkbox"/> See patent family annex.		
40	* Special categories of cited documents:	“T” later document published after the international filing date or priority date and not in conflict with the application but cited to understand the principle or theory underlying the invention	
	“A” document defining the general state of the art which is not considered to be of particular relevance	“X” document of particular relevance; the claimed invention cannot be considered novel or cannot be considered to involve an inventive step when the document is taken alone	
45	“E” earlier application or patent but published on or after the international filing date	“Y” document of particular relevance; the claimed invention cannot be considered to involve an inventive step when the document is combined with one or more other such documents, such combination being obvious to a person skilled in the art	
	“L” document which may throw doubts on priority claim(s) or which is cited to establish the publication date of another citation or other special reason (as specified)	“&” document member of the same patent family	
	“O” document referring to an oral disclosure, use, exhibition or other means		
	“P” document published prior to the international filing date but later than the priority date claimed		
50	Date of the actual completion of the international search 19 May 2017	Date of mailing of the international search report 26 May 2017	
55	Name and mailing address of the ISA State Intellectual Property Office of the P. R. China No. 6, Xitucheng Road, Jimenqiao Haidian District, Beijing 100088, China Facsimile No. (86-10) 62019451	Authorized officer CHEN, Yajuan Telephone No. (86-10) 62085757	

Form PCT/ISA/210 (second sheet) (July 2009)

INTERNATIONAL SEARCH REPORT
 Information on patent family members

International application No. PCT/CN2017/078359
--

	Patent Documents referred in the Report	Publication Date	Patent Family	Publication Date
5	CN 205979444 U	22 February 2017	None	
10	CN 106151992 A	23 November 2016	None	
	CN 205037267 U	17 February 2016	None	
	CN 204665062 U	23 September 2015	None	
	CN 103090330 A	08 May 2013	CN 103090330 B	08 October 2014
15	CN 203336496 U	11 December 2013	None	
20				
25				
30				
35				
40				
45				
50				
55				

REFERENCES CITED IN THE DESCRIPTION

This list of references cited by the applicant is for the reader's convenience only. It does not form part of the European patent document. Even though great care has been taken in compiling the references, errors or omissions cannot be excluded and the EPO disclaims all liability in this regard.

Patent documents cited in the description

- CN 201610805092X [0001]