

(19)



(11)

EP 3 516 129 B1

(12)

EUROPEAN PATENT SPECIFICATION

(45) Date of publication and mention of the grant of the patent:

10.07.2024 Bulletin 2024/28

(21) Application number: **17853938.3**

(22) Date of filing: **21.09.2017**

(51) International Patent Classification (IPC):

E04D 13/03 ^(2006.01) **G02B 27/00** ^(2006.01)
F21S 11/00 ^(2006.01) **G02B 5/04** ^(2006.01)
F21V 5/00 ^(2018.01) **F21V 5/02** ^(2006.01)

(52) Cooperative Patent Classification (CPC):

E04D 13/03; F21S 11/007; F21V 5/007; F21V 5/02;
E04D 2013/034; E04D 2013/0345

(86) International application number:

PCT/US2017/052813

(87) International publication number:

WO 2018/057806 (29.03.2018 Gazette 2018/13)

(54) **DAYLIGHT COLLECTORS WITH DIFFUSE AND DIRECT LIGHT COLLECTION**

TAGESLICHTKOLLEKTOREN MIT SAMMLUNG VON DIFFUSEM UND DIREKTEM LICHT

COLLECTEURS DE LUMIÈRE DU JOUR À COLLECTE DE LUMIÈRE DIFFUSE ET DIRECTE

(84) Designated Contracting States:

**AL AT BE BG CH CY CZ DE DK EE ES FI FR GB
GR HR HU IE IS IT LI LT LU LV MC MK MT NL NO
PL PT RO RS SE SI SK SM TR**

(30) Priority: **21.09.2016 US 201615272319**

(43) Date of publication of application:

31.07.2019 Bulletin 2019/31

(73) Proprietor: **Solatube International, Inc.**

Vista, CA 92081 (US)

(72) Inventor: **JASTER, Paul, August**

Vista, CA 92081 (US)

(74) Representative: **D Young & Co LLP**

**3 Noble Street
London EC2V 7BQ (GB)**

(56) References cited:

EP-A2- 2 743 568 WO-A1-2016/149677
WO-A1-2016/149677 WO-A2-02/23258
JP-A- 2001 090 277 JP-A- 2001 090 277
JP-A- H11 167 084 JP-A- H11 167 084
JP-A- S61 180 217 US-A- 2 812 691
US-A- 2 812 691 US-A- 2 993 409
US-A- 2 993 409 US-A- 4 329 021
US-A- 4 329 021 US-A- 5 551 042
US-A1- 2015 167 305

EP 3 516 129 B1

Note: Within nine months of the publication of the mention of the grant of the European patent in the European Patent Bulletin, any person may give notice to the European Patent Office of opposition to that patent, in accordance with the Implementing Regulations. Notice of opposition shall not be deemed to have been filed until the opposition fee has been paid. (Art. 99(1) European Patent Convention).

Description

BACKGROUND

5 **[0001]** This disclosure relates generally to daylighting and to light collectors used in daylighting systems.

Description of Related Art

10 **[0002]** Daylighting systems typically include windows, openings, and/or surfaces that provide natural light to the interior of a building. Examples of daylighting systems include skylights and tubular daylighting device installations. Various devices and methods exist for receiving daylight into a daylighting device. Certain currently known devices and methods for receiving daylight into a daylighting device suffer from various drawbacks.

[0003] US 2 993 409 A (BOYD ROBERT A) 25 July 1961 (1961-07-25) teaches utilization of daylight for lighting the interior of buildings through an opening in a roof or ceiling.

15 **[0004]** JP H11 167084 A (SANYO ELECTRIC CO) 22 June 1999 (1999-06-22) teaches a low-cost sunshine collecting device which can efficiently guide sunshine into a room even when an altitude of the sun is low.

[0005] US 2015/167305 A1 (KASTNER STEVE ROY [US] ET AL) 18 June 2015 discloses a skylight with a sunlight pivot.

SUMMARY

20 **[0006]** Lighting devices and methods for providing daylight to the interior of a structure are disclosed. Some embodiments disclosed herein provide a daylighting device including a tube having a sidewall with a reflective interior surface, a light collecting assembly, and a light reflector positioned to reflect daylight into the light collector. In some embodiments, the light collector is associated with one or more refractive and/or reflective elements configured to increase the amount
25 of light captured by the daylighting device.

[0007] Some embodiments provide an at least partially transparent light-collecting device for directing daylight into a collector base aperture. The device can include a top cover portion and a substantially vertical sidewall portion configured to support the top cover portion above an upper end of the substantially vertical sidewall portion and to define a collector base aperture at a lower end of the substantially vertical sidewall portion. In certain embodiments, the substantially
30 vertical portion has a height that extends between the top cover portion and the collector base aperture, and is configured to receive daylight.

[0008] Some embodiments provide a light-collecting device configured to direct daylight through a collector base aperture and into an interior of a building when the light-collecting device is installed on a roof of the building. The device can include a top cover portion and a sidewall portion. The sidewall can be configured to support the top cover portion above an upper end of the sidewall portion and to define a collector base aperture at a lower end of the sidewall portion. The sidewall portion can have a height that extends between the top cover portion and the collector base aperture, and the height can be greater than a width of the collector base aperture. The light-collecting device can have a prismatic element configured to refract a portion of light that passes through the top portion. The prismatic element can have a
35 planar surface and a prismatic surface. The planar surface can be positioned towards the direction of incoming light and the prismatic surface is opposite the planar surface. The light collecting device can include a reflector configured to turn at least a portion of the refracted light towards the collector base aperture. The light-collecting device can be positioned over an opening in a roof of a building and can direct daylight into the opening in the roof.

[0009] The light-collecting device can include a prismatic element associated with the substantially vertical sidewall portion and configured to turn at least a portion of daylight received by the vertical portion towards the collector base aperture, and a reflector associated with the substantially vertical portion configured to reflect the portion of daylight towards the opening. In certain embodiments, the collector base aperture has a width and is configured to be positioned adjacent to an opening of a building when the light-collecting device is installed as part of a tubular day lighting device installation.

[0010] Certain embodiments disclosed herein provide an at least partially transparent light-collecting device configured to direct daylight through a collector base aperture and into an interior of a building when the light-collecting device can be installed on a roof of the building. The device can include a top cover portion and a substantially vertical sidewall portion configured to support the top cover portion above an upper end of the substantially vertical sidewall portion and to define a collector base aperture at a lower end of the substantially vertical sidewall portion, wherein the substantially
40 vertical portion has a height that extends between the top cover portion and the collector base aperture, and wherein the substantially vertical portion can be configured to receive a substantial amount of daylight during early morning and late afternoon hours. The device can include a prismatic element associated with the substantially vertical sidewall portion and configured to turn at least a portion of daylight received by the vertical portion towards the collector base aperture, as well as an infrared control element associated with the substantially vertical sidewall portion configured to
55

absorb or transmit at least a portion of infrared (IR) light of the portion of daylight. The light-collecting device can be configured to be positioned over an opening in a roof of a building and can be configured to direct daylight into the opening in the roof when the light-collecting device is installed as part of a daylighting device installation.

5 **[0011]** The infrared control element can be configured to absorb the at least a portion of infrared light and reradiate the portion of infrared light away from an interior of the light-collecting device. The infrared control element can include a material having high emissivity characteristics, such as a material having an emissivity value of greater than 0.90. In certain embodiments, the sidewall portion can be configured to absorb the reradiated portion of infrared light. The sidewall portion can be configured to transmit the reradiated portion of infrared light. For example, the sidewall portion can include acrylic.

10 **[0012]** In certain embodiments, the infrared control element can be at least partially secured to the sidewall portion by an adhesive configured to absorb infrared light incident on a surface of the infrared control element. The height of the vertical portion can be greater than the width of the collector base aperture. In certain embodiments, the top cover portion can be substantially flat. In other embodiments, the top cover portion includes a dome-shaped or cone-shaped surface.

15 **[0013]** The vertical portion can include a plurality of vertically-arranged segments, including a top segment and a bottom segment. In some embodiments, addition segments, such as, for example, a middle segment, can be present. The top, middle, and bottom segments can be each approximately 12.7 to 25.4 centimeters in height. In certain embodiments, the top, middle, and bottom segments can be each a uniform height.

20 **[0014]** The infrared control element can be at least partially transparent with respect to infrared light. In certain embodiments, the vertical portion is substantially cylindrically shaped. In such embodiments, the infrared control element can be curved and nestingly disposed along an interior surface of the vertical portion. The vertical portion can include a first semi-circle portion that is at least partially transparent, and a second semi-circle portion that is at least partially reflective. For example, the second semi-circle portion can be configured to absorb a substantial portion of infrared light incident on a surface of the second semi-circle portion. In certain embodiments, the second semi-circle portion includes a surface in thermal communication with a high-emissivity material configured to facilitate radiation of heat away from the second semi-circle portion, such paint having an emissivity value greater than or equal to about 0.9. In certain embodiments, the vertical portion can be integrated with an internally reflective tube configured to channel light towards an interior space of the building.

25 **[0015]** Certain embodiments disclosed herein provide a process of illuminating an interior of a building. The process can include receiving daylight on a substantially vertical surface, turning the daylight towards an opening in a building using a prismatic element disposed within a light-collecting device, and transmitting or radiating a portion of infrared light of the daylight out of the light-collecting device.

30 **[0016]** The process can include radiating the portion of infrared light out of the light-collecting device at least partially by absorbing the portion of infrared light and reradiating the portion of infrared light using material having high emissivity characteristics. In some embodiments, an infrared control element comprises a material that strongly absorbs infrared light in substantial thermal communication with a material having high emissivity characteristics. The high emissivity material can radiate the infrared light away from the daylighting system. In other embodiments, the light-collecting device is configured to transmit infrared light such that it is permitted to escape the light collection system.

35 **[0017]** Certain embodiments provide a process of manufacturing an at least partially transparent light-collecting device for directing daylight into a building interior. The process can include providing a light collecting device configured to receive daylight on a substantially vertical surface when installed on a building having an opening, disposing a prismatic element within the light collecting device, and disposing an infrared control element adjacent to a wall of the light collecting device. The prismatic element can be configured to turn at least a portion of daylight received on the substantially vertical surface towards the opening. The infrared control element can be configured to transmit or absorb infrared light of the portion of daylight.

40 **[0018]** Certain embodiments disclosed herein provide an at least partially transparent light-collecting device configured to direct daylight through a collector base aperture and into an interior of a building when the light-collecting device can be installed on a roof of the building. The light-collecting device can include a top cover portion and a substantially vertical sidewall portion configured to support the top cover portion above an upper end of the substantially vertical sidewall portion and to define a collector base aperture at a lower end of the substantially vertical sidewall portion, wherein the substantially vertical portion has a height that extends between the top cover portion and the collector base aperture, and wherein the substantially vertical portion can be configured to receive a substantial amount of daylight during midday hours. The light-collecting device can include a prismatic element associated with the substantially vertical sidewall portion and configured to turn at least a portion of daylight received by the vertical portion towards the collector base aperture and a reflector associated with the substantially vertical sidewall portion configured to reflect at least a portion of visible light of the portion of daylight towards the opening and absorb or transmit at least a portion of infrared (IR) light of the portion of daylight. In certain embodiments, the light-collecting device is configured to be positioned over an opening in a roof of a building and can be configured to direct daylight into the opening in the roof when the light-collecting

device can be installed as part of a daylighting device installation.

[0019] The reflector can be configured to absorb the at least a portion of infrared light and reradiate the portion of infrared light away from an interior of the light-collecting device. The reflector can include a material having high emissivity characteristics, such as a material having an emissivity value of greater than 0.90. The sidewall portion can be configured to absorb the reradiated portion of infrared light. The sidewall portion can be configured to transmit the reradiated portion of infrared light. For example, the sidewall portion can include acrylic.

[0020] In certain embodiments, the reflector is at least partially secured to the sidewall portion by an adhesive configured to absorb infrared light incident on a surface of the reflector. The height of the vertical portion can be greater than the width of the collector base aperture. The vertical portion can include a plurality of vertically-arranged segments, including a top segment, a middle segment, and a bottom segment. For example, the top, middle, and bottom segments can be each approximately 12.7 to 25.4 centimeters in height. In certain embodiments, the top, middle, and bottom segments can be each a uniform height. The reflector can be associated with the top segment and the middle segment. In some embodiments, the reflector is not associated with and/or does not extend to all of the segments. The reflector can be at least partially transparent with respect to infrared light and/or other wavelengths of radiation that do not contribute to desired illumination of a building.

[0021] The vertical portion can be substantially cylindrically shaped or another suitable shape. Furthermore, the reflector can be curved and nestingly disposed along an interior surface of the vertical portion. In certain embodiments, the vertical portion includes a first semi-circle portion that can be at least partially transparent, and a second semi-circle portion that can be at least partially reflective. For example, the second semi-circle portion can be configured to absorb a substantial portion of infrared light incident on a surface of the second semi-circle portion. The second semi-circle portion can include a surface in thermal communication with a high-emissivity material configured to facilitate radiation of heat away from the second semi-circle portion, such as material including paint with an emissivity value greater than or equal to about 0.9. In certain embodiments, the vertical portion is integrated with an internally reflective tube configured to channel light towards an interior space of the building.

[0022] Certain embodiments disclosed herein provide a process of illuminating an interior of a building. The process can include receiving daylight on a substantially vertical surface, turning the daylight towards an opening in a building using a prismatic element disposed within a light-collecting device, reflecting a portion of visible light of the daylight towards the opening using a reflector, and transmitting or radiating a portion of infrared light of the daylight out of the light-collecting device. The process can include radiating the portion of infrared light out of the light-collecting device at least partially by absorbing the portion of infrared light with an adhesive material and reradiating the portion of infrared light using the adhesive material, such as by using material having high emissivity characteristics.

[0023] Certain embodiments provide a process of manufacturing an at least partially transparent light-collecting device for directing daylight into a building interior. The process can include providing a light collecting device configured to receive daylight on a substantially vertical surface when installed on a building having an opening, disposing a prismatic element within the light collecting device, and disposing a reflector adjacent to a wall of the light collecting device. The prismatic element can be configured to turn at least a portion of daylight received on the substantially vertical surface towards the opening. In addition, the reflector can be configured to reflect visible light of the portion of daylight towards the opening, and transmit or absorb infrared light of the portion of daylight.

[0024] Certain embodiments disclosed herein provide an at least partially transparent light-collecting device configured to direct daylight through a collector base aperture and into an interior of a building when the light-collecting device can be installed on a roof of the building. The device can include a top cover portion and a substantially vertical sidewall portion configured to support the top cover portion above an upper end of the substantially vertical sidewall portion and to define a collector base aperture at a lower end of the substantially vertical sidewall portion, wherein the substantially vertical portion has a height that extends between the top cover portion and the collector base aperture, and wherein the height of the substantially vertical portion can be greater than a width of the collector base aperture. The device can include a prismatic element configured to turn a portion of light that passes through the top cover portion or substantially vertical sidewall portion. The light-collecting device can be configured to be positioned over an opening in a roof of a building and can be configured to direct daylight into the opening in the roof when the light-collecting device is installed as part of a daylighting device installation.

[0025] The device can include a reflector associated with the substantially vertical portion configured to reflect the portion of daylight towards the opening. The collector base aperture can be substantially circular in shape, and the width can be equal to a diameter of the collector base aperture. In certain embodiments, an aspect ratio of the height of the vertical portion to the width of the collector base aperture is greater than 0.5 to 1. For example, the aspect ratio can be greater than 0.75 to 1, 1.2 to 1, 1.5 to 1, 1.7 to 1, 2 to 1, or greater. In certain embodiments, the aspect ratio is in the range of 1.2-1.5 to 1, 1.5-1.75 to 1, 1.75-2.0 to 1, or 0.5-2.75.

[0026] The top cover portion can be substantially flat, or can be at least partially dome, or cone-shaped. The vertical portion can include a plurality of vertically-arranged segments, including a top segment, a middle segment, and a bottom segment. In some embodiments, the top segment is associated with first optical elements having first light-turning

characteristics and the middle portion is associated with second optical elements having second light-turning characteristics. In some embodiments, light transmitting through the bottom segment is not refracted by light-turning optical elements. In certain embodiments, each of the top, middle, and bottom segments has a height that is greater than or equal to about 12.7 centimeters and/or less than or equal to about 25.4 centimeters. The top, middle, and bottom segments can each be greater than 25.4 centimeters in height. For example, the top, middle, and bottom segments can be each approximately 25.4 to 45.7 centimeters in height. In certain embodiments, the top, middle, and bottom segments are each of uniform height.

[0027] In certain embodiments, the vertical portion is substantially cylindrically shaped. The vertical portion can be integrated with an internally reflective tube configured to channel light towards an interior space of the building. The height of the vertical portion can be between 45.7 and 88.9 centimeters or between 88.9 and 114.3 centimeters. In certain embodiments, the width of the collector base aperture is between 20.3 and 40.6 centimeters or between 40.6 and 50.8 centimeters or between 50.8 and 81.3 centimeters. In certain embodiments, the width of the collector base aperture can be configured to be positioned between joists in a roof. In this manner the light-collecting device can be installed without removing portions of the joist.

[0028] Certain embodiments disclosed herein provide an at least partially transparent light-collecting device for directing daylight into a building interior. The light-collecting device can include a top cover portion, a base aperture having a width and configured to be disposed adjacent to an opening of a building, and a substantially vertical portion having a height, the vertical portion extending between the top portion and the base aperture and configured to receive daylight when installed on a building. The light-collecting device can include a reflector associated with the vertical portion, the reflector configured to reflect at least a portion of daylight received by the vertical portion towards the opening. The vertical portion can be associated with a prismatic element configured to turn the portion of daylight received by the vertical portion towards the opening. Furthermore, the height of the vertical portion can be greater than the width of the opening of the building.

[0029] The vertical portion can have a rectangular cross-sectional shape, a substantially elliptical cross-sectional shape, or any other desired cross-sectional shape. The vertical portion can be constructed out of a single planar sheet formed in the shape of an ellipse, wherein two ends of the sheet can be joined to form a singular vertical seam. Alternatively, the vertical portion can include a plurality of horizontally-arranged curved sheets that can be configured to be joined together to form an ellipse. In certain embodiments, the vertical portion has a substantially triangular cross-sectional shape.

[0030] Certain embodiments disclosed herein provide a process of illuminating an interior of a building. The process can include receiving daylight on a substantially vertical surface, turning the daylight towards an aperture lying in a substantially horizontal plane using a prismatic element disposed within a light-collecting device, and reflecting the daylight towards the opening using a reflector. The substantially vertical surface may a height greater than a width of the aperture.

[0031] Certain embodiments disclosed herein provide a process of manufacturing an at least partially transparent light-collecting device for directing daylight into a building interior. The process can include providing a light collecting device configured to receive daylight on a substantially vertical surface when installed on a building having an opening and disposing a reflector adjacent to a wall of the light collecting device. The reflector can be configured to reflect the portion of daylight towards the opening through a base aperture of the light collecting device, the substantially vertical surface having a height that can be greater than a width of the base aperture.

[0032] Certain embodiments disclosed herein provide a passive light-collecting device for directing sunlight into a building interior. The light-collecting device can include a top cover portion, a base aperture having a width and configured to be disposed adjacent to an opening of a building, and a substantially vertical portion having a height that extends between the top portion and the base aperture and can be configured to receive sunlight. The light-collecting device can be configured to direct a first luminous flux through the base aperture when the light-collecting device is exposed to sunlight at a solar altitude of approximately 30 degrees, and to direct a second luminous flux through the base aperture when the light-collecting device is exposed to sunlight at a solar altitude of approximately 70 degrees, wherein the first luminous flux is greater than or equal to about 75% of the second luminous flux when the light-collecting device is exposed to substantially only direct sunlight on a clear day.

[0033] The light-collecting device can include a prismatic element associated with the vertical portion and configured to turn at least a portion of sunlight received by the vertical portion towards the base aperture. The light-collecting device can include a reflector associated with the vertical portion configured to reflect the portion of sunlight towards the base aperture. In certain embodiments, the height of the vertical portion can be greater than the width of the base aperture.

[0034] In certain embodiments, the top cover portion is substantially flat. The top cover portion can include a dome-shaped surface, a cone-shaped surface, a planar surface, a faceted surface, another surface shape, or a combination of surface shapes. The top cover can be associated with a second prismatic element configured to turn sunlight incident on the top cover towards the base aperture. The second luminous flux can be greater than 18,000 lumens.

[0035] In certain embodiments, the vertical portion is substantially cylindrically shaped. The vertical portion can include

a plurality of vertically-arranged segments, including a top segment, a middle segment, and a bottom segment. For example, the top segment can be associated with a first prismatic element having first light-turning characteristics and the middle portion can be associated with a second prismatic element having second light-turning characteristics. The bottom segment may not be associated with light-turning optical elements. The top, middle, and bottom segments can be each approximately 12.7 to 25.4 centimeters in height, and may each be of uniform height.

[0036] The vertical portion can be integrated with an internally reflective tube configured to channel light towards an interior space of the building. The height of the vertical portion can be between 50.8 and 63.5 centimeters, or between 88.9 and 114.3 centimeters. In certain embodiments, the reflector is disposed adjacent to an interior surface of the substantially vertical portion. Alternatively, the reflector can be disposed adjacent to an outer surface of the substantially vertical portion.

[0037] Certain embodiments disclosed herein provide a passive light-collecting device for directing sunlight into a building interior. The light-collecting device can include a top cover portion, a base aperture having a width and configured to be disposed adjacent to an opening of a building, and a substantially vertical portion having a height that extends between the top portion and the base aperture and can be configured to receive sunlight. The light-collecting device can be configured to direct a first luminous flux through the base aperture when the light-collecting device is exposed to sunlight at a solar azimuth of approximately 45 degrees and a first solar altitude, and direct a second luminous flux through the base aperture when the light-collecting device can be exposed to sunlight at a solar azimuth of approximately 0 degrees, wherein the first luminous flux can be greater than or equal to about 75% of the second luminous flux when the light-collecting device can be exposed to substantially only direct sunlight on a clear day.

[0038] The light-collecting device can include a prismatic element associated with the vertical portion and configured to turn at least a portion of sunlight received by the vertical portion towards the base aperture. The light-collecting device can include a reflector associated with the vertical portion configured to reflect the portion of sunlight towards the base aperture. In certain embodiments, the second luminous flux can be greater than 18,000 lumens.

[0039] Certain embodiments disclosed herein provide an at least partially transparent light-collecting device for directing sunlight into a building interior. The light-collecting device can include a top cover portion, a base aperture having a width and configured to be disposed adjacent to an opening of a building, and a substantially vertical portion having a height that extends between the top portion and the base aperture and can be configured to receive sunlight. The light-collecting device can be configured to direct a first luminous flux through the base aperture when the light-collecting device can be exposed to sunlight at a solar altitude of approximately 30 degrees and a solar azimuth of approximately 45 degrees, and direct a second amount of light through the base aperture when exposed to sunlight at a solar altitude of approximately 70 degrees and a solar azimuth of approximately 0 degrees, wherein the first luminous flux can be greater than or equal to about 75% of the second luminous flux when the light-collecting device can be exposed to substantially only direct sunlight on a clear day.

[0040] The light-collecting device can include a prismatic element configured to turn at least a first portion of sunlight received by the vertical portion towards the base aperture. The light-collecting device can include a reflector associated with the vertical portion, the reflector configured to reflect at least a second portion of the sunlight received by the vertical portion towards the base aperture.

[0041] In certain embodiments, the top cover can be associated with a second prismatic element configured to turn sunlight incident on the top cover towards the base aperture, and can be substantially flat. The vertical portion may have a substantially rectangular, elliptical, triangular, hexagonal, pentagonal, or octagonal cross-sectional shape.

[0042] Some embodiments provide an at least partially transparent light-collecting device for directing daylight into a collector base aperture. The device can include a top cover portion and a sidewall portion. The top cover portion positioned above an upper end of the sidewall portion and the collector base aperture is at a lower end of the sidewall portion. A prismatic element can be associated with the top portion. The prismatic element can have a planar surface and a prismatic surface. The planar surface can be positioned to face outward from the top portion toward the direction of incoming light providing a first refraction of daylight and the prismatic surface can be positioned opposite the planar surface to provide a second refraction of daylight toward the collector base aperture. In certain embodiments, the light-collecting device can include a prismatic element associated with the sidewall portion and configured to turn at least a portion of daylight received by the towards the collector base aperture. The prismatic element can have a planar surface and a prismatic surface. The prismatic surface can be positioned towards the direction of incoming light and the planar surface is opposite the prismatic surface. The light collecting device can include a reflector associated with the sidewall portion configured to reflect the portion of daylight towards the opening. In certain embodiments, the collector base aperture has a width and is configured to be positioned adjacent to an opening of a building when the light-collecting device is installed as part of a tubular daylighting device installation. In some embodiments the top cover portion may be angled, such as, for example, 20° from horizontal.

[0043] Certain embodiments disclosed herein provide a process of illuminating an interior of a building. The process can include receiving first sunlight having a solar altitude of approximately 30 degrees on a vertical surface, directing the first sunlight into an opening in a building, receiving second sunlight having a solar altitude of approximately 70

degrees on the vertical surface, and directing the second sunlight into the opening in the building. The first sunlight and the second sunlight can include direct sunlight, and the first sunlight can include a luminous flux that is greater than or equal to about 75% of a luminous flux of the second sunlight when said receiving the first sunlight and receiving the second sunlight are performed on a clear day.

5 **[0044]** An aspect of the subject matter disclosed herein is implemented in a skylight comprising a skylight cover, a prismatic element and an element positioning assembly. The prismatic element is configured to refract at least a portion of light that passes through the skylight cover. The prismatic element comprises a non-prismatic surface and a prismatic surface, the prismatic surface being opposite the non-prismatic surface. The non-prismatic surface is positioned between
10 the prismatic surface and the skylight cover. The prismatic surface comprises at least one prism having a riser surface and a draft surface. A riser angle of the riser surface has a value between about 35 degrees and about 43 degrees or between about 47 degrees and about 85 degrees with respect to a surface normal to the non-prismatic surface. The element positioning assembly is configured to position the skylight cover over an opening in a roof of a building. The element positioning assembly is further configured to dispose the prismatic element relative to the plane of the roof such that an angle formed at an intersection of a second plane including the prismatic element and the plane of the roof is
15 between 0 and about 40 degrees. The element positioning assembly is further configured to orient the prismatic element such that the riser surface faces the sun and directs daylight into the opening in the roof.

[0045] In various embodiments of the skylight, the draft surface can be inclined by a draft angle that is different from the riser angle. In various embodiments, the riser angle can be between about 45 degrees and about 55 degrees. The prismatic element can comprise a prismatic film having at least one surface positioned parallel to the skylight cover. The
20 prismatic element can comprise a plurality of prismatic grooves. At least a portion of the prismatic grooves can be formed in at least one of a radial pattern, a linear pattern, or a curve-linear pattern. The prismatic element can be positioned up to 40 degrees from horizontal. For example the prismatic element can be positioned up to 40 degree with respect to a plane parallel to the ground.

[0046] In various embodiments of the skylight, the skylight cover can be angled relative to a plane of the roof. The
25 skylight cover can have a pole side and an equatorial side. The equatorial side can be positioned closer to the equator and the pole side can be positioned opposite the equatorial side. The pole side of the skylight cover can be offset from the roof, and the equatorial side of the skylight cover can be positioned closer to the roof than the pole side of the skylight cover. In various embodiments, the skylight cover can be clear. The skylight cover can be substantially flat, angled, or at least partially dome-shaped. The prismatic element can be integrally formed with the skylight cover.

30 **[0047]** Another innovative aspect of the subject matter disclosed herein is implemented in a skylight assembly comprising a skylight cover, a prismatic element and an element positioning assembly. The prismatic element is configured to refract at least a portion of light that passes through the skylight cover. The prismatic element comprises a non-prismatic surface and a prismatic surface, the prismatic surface being opposite the non-prismatic surface. The non-prismatic surface is positioned between the prismatic surface and the skylight cover. The element positioning assembly
35 is configured to position the skylight assembly over an opening in a roof of a building. The element positioning assembly is configured to dispose the prismatic element relative to the plane of the roof such that an angle formed at an intersection of a second plane containing the prismatic element and the plane of the roof is between 0 and about 40 degrees. The element positioning assembly is further configured to orient the prismatic element so that the riser surface faces the sun and directs daylight into the opening in the roof.

40 **[0048]** In various embodiments of the skylight assembly, the positioning assembly can include at least one of: an adhesive that bonds the prismatic element to the skylight cover; a frame that holds the prismatic element within 15.2 centimeters of the skylight cover; a spacer configured to be positioned between the prismatic element and the skylight cover; a tab or slot for attachment to the prismatic element; or an adhesive that bonds the prismatic element to a portion of the skylight assembly near the skylight cover. In various embodiments of the skylight, angling the prismatic element
45 can form a raised side of the prismatic element along at least one edge of the prismatic element. The raised side can be a side other than the side of the prismatic element closest to the equator. The prismatic element can be aligned with the angle of the skylight cover. The position the prismatic element can be less than or equal to 15.2 centimeters from the plane of the roof.

[0049] Another innovative aspect of the subject matter disclosed herein is implemented in a method of installation of
50 a skylight assembly. The method comprises providing a skylight assembly and positioning the skylight assembly over an opening in a roof of a building. The skylight assembly comprises a skylight cover; and a prismatic element configured to refract at least a portion of light that passes through the skylight cover. The prismatic element comprises a planar surface and a prismatic surface, the prismatic surface being opposite the planar surface. The planar surface is positioned between the prismatic surface and the skylight cover. The prismatic surface comprises at least one prism having a riser
55 surface and a draft surface. The method further comprises orienting the skylight so that the riser surface faces the sun and directs daylight into the opening in the roof when the skylight is installed as part of a skylight installation.

[0050] Various embodiments of the method can further comprise positioning the prismatic element so that no portion of the prismatic element is above s 15.2 centimeters of the plane of the roof. The method can further comprise angling

the prismatic element up to 40 degrees relative to the plane of the roof. The method can further comprise securing the prismatic element within the skylight assembly. In various embodiments of the method, securing the prismatic element can further comprise at least one of: bonding the prismatic element to the skylight cover using an adhesive; attaching the prismatic element to a frame that holds the prismatic element within 15.2 centimeters of the skylight cover; positioning a spacer between the prismatic element and the skylight cover; attaching the prismatic element a tab or slot within the skylight assembly; or bonding the prismatic element to a portion of the skylight assembly near the skylight cover using an adhesive.

[0051] Another aspect of the subject matter disclosed herein is implemented in a skylight assembly comprising a skylight cover, a prismatic element, and an element positioning assembly. The prismatic element is configured to refract at least a portion of light that passes through the skylight cover. The prismatic element comprises a non-prismatic surface and a prismatic surface, the prismatic surface being opposite the non-prismatic surface. The non-prismatic surface is positioned between the prismatic surface and the skylight cover. The element positioning assembly is configured to position the skylight assembly over an opening in a roof of a building. The element positioning assembly is further configured to position the prismatic element so that no portion of the prismatic element is above 15.2 centimeters of the plane of the roof, and orient the prismatic element so that the riser surface faces the sun and directs daylight into the opening in the roof. In various embodiments of the skylight, the prismatic element can be positioned below the plane of the roof. Various aspects and features of the present disclosure are defined in the appended claims.

BRIEF DESCRIPTION OF THE DRAWINGS

[0052] Various embodiments are depicted in the accompanying drawings for illustrative purposes, and should in no way be interpreted as limiting the scope of the inventions. In addition, various features of different disclosed embodiments can be combined to form additional embodiments, which are part of this disclosure. Any feature or structure can be removed or omitted. Throughout the drawings, reference numbers can be reused to indicate correspondence between reference elements.

FIG. 1 illustrates a block diagram representing an embodiment of a daylighting device.

FIG. 2 illustrates a cutaway view of an example of a daylighting device installed in a building for illuminating an interior room of the building.

FIG. 3 illustrates a cutaway view of an example of a daylighting device installed in a building for illuminating an interior room of the building.

FIG. 4 illustrates a cutaway view of an example of a daylighting device installed in a building.

FIG. 5 illustrates an embodiment of a daylighting device incorporating a collimator at a terminal portion of the daylighting device.

FIG. 6 illustrates an embodiment of the light collector shown in FIG. 1.

FIG. 7 illustrates an embodiment of a daylighting device including a light collector with a dome-shaped top portion.

FIG. 8 illustrates an embodiment of a daylighting device with a top portion having a triangular cross-section.

FIGS. 9A-9F illustrate embodiments of light collectors having various cross-sectional shapes.

FIGS. 10A-10D illustrate embodiments of a cross-sectional view of a light collector including both a side portion, and a top portion.

FIGS. 10E and 10F illustrate embodiment of a daylighting system with a skylight cover that can be disposed near a roof of a building for improved illumination.

FIG. 10G illustrates an embodiment of light propagation through a daylighting device comprising a prismatic element and a daylighting device without a prismatic element.

FIG. 11A illustrates a cross-sectional view of a portion of the prismatic element shown in FIG. 10A.

FIG. 11B illustrates a cross-sectional view of a portion of the prismatic element shown in FIG. 10A.

FIG. 12 illustrates a cross-sectional view of a light collector including a side portion that includes a plurality of vertically arranged optical zones.

FIGS. 13A-13C illustrate embodiments of various prismatic patterns.

FIG. 14A illustrates a perspective view of an embodiment of a light reflector for disposing within, adjacent to, or in integration with, a light collecting assembly.

FIG. 14B illustrates a top view of an embodiment of the reflector shown in FIG. 14A

FIG. 14C illustrates a cross-sectional view of a vertically-oriented planar reflector.

FIG. 15 illustrates a perspective view of an embodiment of daylighting device including a light collector incorporating a reflector.

FIG. 16 illustrates a perspective view of an embodiment of daylighting device including a light collector incorporating a reflector.

FIG. 17A illustrates an embodiment of a light collector having a transparent portion and a reflector assembly.

FIG. 17B illustrates a top view of an embodiment of a connecting structure of a light collector.

FIG. 18 illustrates an embodiment of a light collector having a reflector assembly with a high-emissivity coating.

FIG. 19 illustrates an embodiment of a daylighting device including a light collector having prismatic and reflective optical elements.

5 FIG. 20 illustrates a perspective view of an embodiment of a light collector.

FIG. 21A illustrates an embodiment of a light collector formed from a singular panel.

FIG. 21B illustrates a top view of an embodiment of a portion of a light collector having a circumference that includes multiple curved panels.

FIG. 22 illustrates a packaging configuration for an embodiment of one or more curved light collector panels.

10 FIG. 23 illustrates a packaging configuration for an embodiment of one or more curved light collector panels.

FIG. 24 is a graph showing reflectivity profiles of two different reflective materials.

FIG. 25 illustrates relative performance of various embodiments of light collectors.

DETAILED DESCRIPTION OF CERTAIN EMBODIMENTS

15 **[0053]** Although certain embodiments and examples are disclosed herein, inventive subject matter extends beyond the examples in the specifically disclosed embodiments to other alternative embodiments and/or uses, and to modifications and equivalents thereof. Thus, the scope of the claims appended hereto is not limited by any of the particular embodiments described below. For example, in any method or process disclosed herein, the acts or operations of the method or process can be performed in any suitable sequence and are not necessarily limited to any particular disclosed sequence. Various operations can be described as multiple discrete operations in a manner or order that can be helpful in understanding certain embodiments; however, the order of description should not be construed to imply that these operations are order-dependent. Additionally, the structures, systems, and/or devices described herein can be embodied as integrated components or as separate components. For purposes of comparing various embodiments, certain aspects and advantages of these embodiments are described. Not necessarily all such aspects or advantages are achieved by any particular embodiment. Thus, for example, various embodiments can be carried out in a manner that achieves or optimizes one advantage or group of advantages as taught herein without necessarily achieving other aspects or advantages as can be taught or suggested herein.

20 **[0054]** FIG. 1 depicts a block diagram representing an embodiment of a daylighting device 100. The daylighting device 100 can be a passive light-collection and distribution system for providing daylight to an interior of a building or other structure. The daylighting device 100 includes a light collector 110 which is exposed, either directly or indirectly to a source of light, such as, for example, the Sun. Light enters the light collector and propagates into a tube 120. For example, the light may enter the light collector 110 through a sidewall portion and/or a top cover portion of the light collector. The sidewall portion can be a substantially vertical daylight-collection surface. The tube 120 provides a channel, or pathway, between the light collector 110 and a light-aligning structure 130. The interior surface of the tube 120 is at least partially reflective. In some embodiments, at least a portion of the interior surface of the tube 120 is specularly reflective or is at least partially specular.

25 **[0055]** As used herein, the terms "substantially vertical" and "vertical" are used in their broad and ordinary sense and include, for example, surfaces that are generally perpendicular to the ground, surfaces that are generally perpendicular to a horizontal plane, and/or surfaces that deviate by less than about 10° from a plane perpendicular to the ground and/or a horizontal plane. Such surfaces can be planar, curved, or irregularly shaped while still being substantially vertical so long as an elongate dimension of a surface is generally vertical. The terms "substantially horizontal" and "horizontal" are used in their broad and ordinary sense and include, for example, surfaces that are generally parallel to the ground, surfaces that are generally parallel to the roof of a building, and/or surfaces that deviate by less than or equal to about 30 10° from a plane parallel to the ground and/or a roof. Such surfaces can be planar, curved, or irregularly shaped while still being substantially horizontal so long as an elongate dimension of a surface is generally horizontal.

35 **[0056]** The light collector permits exterior light, such as natural light, to enter the interior of the reflective tube 120. The light collector 110 can have one or more components. For example, the light collector 110 can include a transparent dome, a prismatic dome, other prismatic elements, one or more light turning structures or elements, a durable cover, one or more reflective surfaces (e.g., positioned inside or outside of a portion of the collector 110), other optical elements, other components, or a combination of components. At least some components of the light collector can be configured to be positioned on the roof 102 of the building or in another suitable area outside the building. The light collector 110 can include a transparent cover installed on the roof 102 of the building or in another suitable location. The transparent cover can be cylindrically shaped, dome-shaped, or can include any other suitable shape or combination of shapes, and can be configured to capture sunlight during certain periods of the day. In certain embodiments, the cover keeps environmental moisture and other material from entering the tube. The cover can allow exterior light, such as daylight, to enter the system.

40 **[0057]** In the example embodiments disclosed, the measure h_c represents a height of a substantially vertical sidewall

portion of the light collector 110. In certain embodiments, the sidewall portion presents a substantially vertical daylight-collection surface through which daylight may enter the daylighting device 100. The measure w_c represents a width of a portion of the collector, such as the width of the base or top portions of the collector 110. In certain embodiments, the width of the collector is substantially uniform over its height h_c . The width w_c of the collector at its base can be greater than the width of the tube 120 at a point near the collector base. In some embodiments, a daylight device is configured such that a width of the tube into which daylight is directed, at least in a region disposed in proximity to the collector base, is less than the height h_c of the collector. The width of the tube w_t may represent a width of a target area to which the light collector 110 is configured to direct daylight entering the collector. The term "target area" is used herein according to its broad and ordinary meaning and can be used to refer to an area through which a daylight collector is configured to direct daylight in order for the daylight to enter an internally-reflective tube between a roof structure and interior room of a building.

[0058] The relationship between the height of the collector and the width of the tube or width of the target area of the collector can be characterized using a ratio between the quantities that will be referred to herein as the aspect ratio. In general, the aspect ratio refers to the ratio between the height of the collector and the width of the tube with which the collector is configured to be used. For example, in some embodiments, the height h_c of the collector, as compared to the width w_t of the tube/target area 120, or width w_c of the collector 110, can have an aspect ratio of approximately 0.5 to 1, 0.75 to 1, 0.8 to 1, 0.9 to 1, 1 to 1, 1.2 to 1, greater than or equal to any of the foregoing aspect ratios, less than or equal to 2.75 to 1, or within a range bounded by any two of the foregoing aspect ratios. In certain embodiments, the aspect ratio is in the range of 1.2-1.5 to 1, 1.0-1.75 to 1, 0.75-2.0 to 1, or 0.5-2.75. The term "collector" is used herein according to its broad and ordinary meaning and includes, for example, a cover, window, or other component or collection of components, configured to direct daylight into an opening of a building. A collector can include optical elements that refract and/or reflect daylight such that the luminous flux of natural light entering a building is greater than if an opening in the building included a fenestration apparatus without optical elements.

[0059] In some embodiments, the cover includes a light collection system configured to enhance or increase the daylight entering the tube 120. The collector 110 can include one or more optical elements, either integrated or non-integrated with respect to the cover, configured to turn light entering one or more portions of the collector 110 generally in the direction of the tube 120, or opening in the building. The light collector 110 can include a top cover. For example, the top cover can be clear and/or include prisms for refracting daylight toward the collector base aperture. The prisms can be fabricated into the cover material or can be formed in a separate prismatic element placed beneath or above a clear dome. As used herein, prismatic element is used in its broad and ordinary sense and includes, for example, prismatic films, molded prismatic assemblies, extruded prismatic materials, another prismatic material, or a combination of materials.

[0060] The daylighting device 100 can be configured such that light enters the collector 110 and proceeds through the tube 120, which can be internally reflective, thereby allowing light to propagate through the tube to a targeted area of the building. An auxiliary lighting system (not shown) can be installed in the daylighting device 100 to provide light from the tube to the targeted area when daylight is not available in sufficient quantity to provide a desired level of interior lighting.

[0061] The collimator 130 can be configured such that light that would otherwise enter the diffuser at undesirable angles is turned to a more desirable angle. For example, the collimator 130 can ensure that light passing through the daylighting device will exit the daylighting device at an exit angle of less than or equal to about 45 degrees from vertical, or at a substantially vertical orientation, when the diffuser 140 is in a horizontal arrangement. In some embodiments, the collimator 130 may ensure that light passing through the daylighting device will exit the daylighting device at an exit angle of less than or equal to about 45 degrees from a longitudinal axis of the daylighting device or a portion of the daylighting device. In certain embodiments, the collimator 130 is configured to reduce or prevent light from exiting the daylighting device 100 at an angle of between about 45 degrees and about 60 degrees from vertical. In this manner, the collimator 130 may reduce or eliminate glare and visibility issues that light exiting a lighting fixture between those angles can cause.

[0062] The daylighting device 100 includes a light-diffusing structure, or diffuser 140. The diffuser 140 spreads light from the tube into the room or area in which it is situated. The diffuser 140 can be configured to distribute or disperse the light generally throughout a room or area inside the building. Various diffuser designs are possible.

[0063] When the daylighting device 100 is installed, the tube 120 can be physically connected to, or disposed in proximity to, the light-aligning structure, or collimator 130, which is configured to turn light propagating through the daylighting device such that, when light exits the daylighting device 100 and/or enters a diffuser 140, the light has increased alignment characteristics, as compared to a device without a collimator. In some embodiments, a substantial portion of light propagating through the daylighting device 100 may propagate within the daylighting device at relatively low angles of elevation from a horizontal plane of reference. Such angles of propagation may, in some situations, cause the light to have undesirable properties when it exits the daylighting device. For example, the optical efficiency of a diffuser substantially positioned within a horizontal plane can be substantially reduced when light is incident on the

diffuser at low angles of elevation from the horizontal plane. As another example, light that is incident on a diffuser at low angles of elevation can result in light exiting the daylighting device at an exit angle of greater than or equal to about 45 degrees from vertical. Light exiting a daylighting device at such angles can create glare and visibility issues in the area or room being illuminated.

5 **[0064]** Though the embodiment depicted in FIG. 1 is described with reference to one or more features or components, any of the described features or components can be omitted in certain embodiments. Furthermore, additional features or components not described can be included in certain embodiments in accordance with the device shown in FIG. 1.

10 **[0065]** FIG. 2 shows a cutaway view of an example of a daylighting device 200 installed in a building 205 for illuminating, with natural light, an interior room 207 of the building. The daylighting device 200 can be suited for use in commercial, high-bay applications, such as in structures or buildings having ceilings above 6.096 meters high. For example the distance h_0 between the floor 208 and a ceiling plane 209 can be in the range of approximately 6.096 - 8.534 meters. The daylighting device 200 can be configured to improve the performance of a light collection system through the use of a light collector 210, wherein the light collector 210 incorporates, or is associated with, one or more passive optical elements. The daylighting device 200 can be particularly configured for applications that operate within an approximately 15 six-hour window during which daylight is most intense. For example, depending on geographical location of the building 202, among possibly other things, the daylighting device 200 can be configured to capture desirable amounts of daylight between the hours of 9:00am and 3:00pm.

20 **[0066]** The light collector 210 can be mounted on a roof 202 of the building and may facilitate the transmission of natural light into a tube 220. In certain embodiments, the collector 210 is disposed on a pitched roof. In order to compensate for the pitch in the roof, the collector 210 can be mounted to the roof 202 using a flashing 204. The flashing can include a flange 204a that is attached to the roof 202, and a curb 204b that rises upwardly from the flange 204a and is angled as appropriate for the cant of the roof 202 to engage and hold the collector 210 in a generally vertically upright orientation. Other orientations are also possible. In certain embodiments, at least a portion of the roof 202 is substantially flat.

25 **[0067]** The light collector 210 has a height h_c and is disposed adjacent to a tube opening having a width, or diameter, w_t . The tube opening may provide a target area into which the light collector 210 is configured to direct daylight. As used herein, the height h_c may refer to the height of a substantially vertical sidewall portion of the collector 210, or may refer to the height of the collector 210 including the height of a cover portion disposed above the vertical portion. In certain embodiments, the substantially vertical sidewall portion may provide a vertical daylight-collection surface for daylight incident on certain portions of the collector 210. In certain embodiments, the height h_c is approximately 25 50.8 - 66.0 centimeters. In other embodiments, the height h_c can be approximately 88.9 - 114.3 centimeters. In addition, the width w_t of the tube opening can be between 38.1 - 76.2 centimeters. For example, in an embodiment, the height h_c of the collector 210 is approximately 106.7 centimeters and the width w_t of the tube opening is approximately 63.5 centimeters. The collector 210 may have a width w_c slightly greater than the width w_t of the tube opening such that when the light collector is disposed above the tube opening, a lip of the collector 210 extends beyond the width of the tube opening. 30 For example, the collector 210 may have a 2.5 centimeter lip around a circumference or perimeter of the tube opening, such that the width w_c of the collector 210 is approximately 5.1 centimeters greater than the width of the tube opening w_t . The height h_c of the collector 210 and the width w_t of the tube opening can be configured to obtain a desirable aspect ratio that provides satisfactory performance characteristics. In certain embodiments, the aspect ratio of height h_c to width w_t is approximately 1.7:1. In some embodiments, the aspect ratio is greater than or equal to about 0.5:1 and/or less than or equal to about 2.75: 1. Such aspect ratios, in connection with daylighting device features described herein, may provide improved daylight capturing characteristics.

35 **[0068]** The tube 220 can be connected to the flashing 204 and can extend from about a level of the roof 202 through a ceiling level 209 of the interior room 207. The tube 220 can direct light L_{D2} that enters the tube 220 downwardly to a light diffuser 240, which disperses the light in the room 207. The interior surface of the tube 220 can be reflective. In some embodiments, the tube 220 has at least a section with substantially parallel sidewalls (e.g., a generally cylindrical inside surface). Many other tube shapes and configurations are possible. The tube 220 can be made of metal, fiber, plastic, other rigid materials, an alloy, another appropriate material, or a combination of materials. For example, the body of the tube 220 can be constructed from type 1150 alloy aluminum. The shape, position, configuration, and materials of the tube 220 can be selected to increase or maximize the portion of daylight L_{D1} , L_{D2} or other types of light entering the tube 220 that propagates into the room 207. 40

45 **[0069]** The tube 220 can terminate at, or be functionally coupled to, a light diffuser 240. The light diffuser 240 can include one or more devices that spread out or scatter light in a suitable manner across a larger area than would result without the diffuser 240 or a similar device. In some embodiments, the diffuser 240 permits most or substantially all visible light traveling down the tube 220 to propagate into the room 207. The diffuser can include one or more lenses, ground glass, holographic diffusers, other diffusive materials, or a combination of materials. The diffuser 240 can be connected to the tube 220, or other component of the daylighting device 200, using any suitable connection technique. In some embodiments, the diffuser 240 is located in the same general plane as a ceiling level 209 of the building, generally parallel to the plane of the ceiling level 209, or near the plane of the ceiling level 209. In certain embodiments, 50

the building 205 has an open ceiling, exposing structure associated with the roof 202. For example, certain high-bay buildings may have open-ceiling configurations, exposing structural I-beams and/or the like. In an open ceiling configuration, the diffuser 240 can be disposed adjacent to a ceiling-level plane 209, rather than a physical ceiling structure.

5 [0070] In certain embodiments, the diameter of the diffuser 240 is substantially equal to the diameter of the tube 220, slightly greater than the diameter of the tube 220, slightly less than the diameter of the tube 220, or substantially greater than the diameter of the tube 220. The diffuser 240 can distribute light incident on it toward a lower surface below the diffuser (e.g., the floor 208) and, in some room configurations, toward an upper surface of the room 207. In some embodiments, a diffuser 240 provides substantial amounts of both direct diffusion and indirect diffusion. In some embodiments, the diffuser 240 reduces the light intensity in one or more regions of the room interior 207.

10 [0071] One or more daylighting devices configured according to the embodiment described with respect to FIG. 2 may increase illumination of a building, or decrease the number of devices required to achieve a desired amount of light infusion into the building. For example, certain embodiments described herein may improve performance and/or reduce the number of required devices by 20-30%.

15 [0072] The daylighting device 200 can be configured to sustain significant physical stress without substantial structural damage. For example, in certain embodiments, the daylighting device 200 is configured to withstand a drop test, wherein a bag of sand having particular weight/size characteristics is dropped onto the top of the device from a minimum height. To pass such test, the device can be required to withstand the fall test without allowing the bag to fall through the opening in the building. In some embodiments, a daylighting system is configured to meet standards and/or regulations promulgated by standards organizations and/or government agencies that are designed to improve the safety of rooftop environments containing day lighting fixtures. For example, certain embodiments are configured to meet the Federal Occupational Safety and Health Administration (OSHA) regulations, which provide, for example, that skylight screens shall be of such construction and mounting that they are capable of withstanding a load of at least 200 pounds applied perpendicularly to a surface. Daylighting devices can be constructed to meet regulatory standards. In certain embodiments, one or more portions of the flashing 204, and/or collector 210 can be constructed and/or mounted such that the collector 210 is not damaged to the extent that an opening or aperture providing an ingress into the building interior 207 is created therein, when a 267-lb. sand bag, having an approximately 5.5" bull nose, is dropped generally perpendicularly to a plane of the roof and/or to a top surface of the collector 210 from a height of about 36" above the roof onto the center of the top portion of the daylight collector.

25 [0073] FIG. 3 shows a cutaway view of an example of a daylighting device 300 installed in a building 305 for illuminating, with natural light, an interior room 307 of the building. The daylighting device 300 includes a light collector 310 mounted on a roof structure 302 of the building 305 that allows natural light to enter a tube 320. In the depicted embodiment, the daylighting device 300 includes an insulation structure, or layer, 306 disposed adjacent to, or within, the tube 320. The insulation structure 306 can be configured to reduce a rate of thermal energy transfer between the interior of the daylighting device 300 and the room 307. For example, the insulation structure 306 can be disposed adjacent to a diffuser 340, such as between the diffuser 340 and the interior of the tube 320. The insulation structure 306 can be disposed at any other suitable position, such as near the top of the tube 320, near the level of a ceiling, or near the level of the collector 310. In some embodiments, the insulation structure 306 can be positioned at the same level as an insulation layer found in the building, and can be positioned to provide a substantially contiguous layer of insulation together with the building insulation layer. The daylighting device 300 can also include insulation structures disposed in various positions or locations. The position(s) of the insulation structure(s) 306 can be selected to produce any desired thermal energy transfer characteristics.

30 [0074] In the embodiment depicted in FIG. 3, the diffuser 340 is disposed adjacent to, and in a substantially parallel alignment with, a surface 370 of the roof structure 302. As shown, the tube 320 may extend from the light collector 310 and through at least a portion of the roof structure 302, without extending substantially into the interior room space 307. In certain embodiments, the daylighting device 300 can include a light collector configured to provide light to the interior room 307 without the use of a tube 320. For example, the light collector 310 may extend through the roof structure 302, and connect directly with the diffuser 340.

35 [0075] FIG. 4 shows a cutaway view of an example of a daylighting device 400 installed in a building 405. The daylighting device 400 includes a light collector 410 mounted on a roof 402 of the building 405 that allows natural light to enter a tube 420. In certain building applications, such as high-bay building applications, light provided by a daylighting system can be at least partially blocked or undesirably redirected by one or more obstructions disposed in the vicinity of the system's lower perimeter, or along the path of light between the system and a desired area of illumination. The daylighting device 400 can be configured to extend below one or more possible obstructions, or low enough to reduce the effects of one or more obstructions on lighting performance. In certain embodiments, the effect of obstructions on lighting performance is reduced by incorporating a daylighting device that maintains a substantial portion of its transmitted light within a cone half angle of less than approximately 40-45°. In the depicted embodiment, the tube extends through the roof 402, and a distance d below a ceiling level 409. The ceiling level 409 can be a physical ceiling structure, or may represent a ceiling level in an open-ceiling building configuration. The ceiling level can be, for example, at approximately

the same level as one or more I-beam structures, or other building structure. In an embodiment including a physical ceiling structure 409, the daylighting device 400 can include an insulation structure disposed adjacent to the ceiling level 409.

[0076] In certain embodiments, the daylighting device 400 includes a thermal insulation subsystem, or portion 406, that substantially inhibits thermal communication between the interior 407 of a structure and the outside environment. The thermal insulation subsystem can have any suitable configuration, such as, for example, one of the configurations disclosed in U.S. Patent Application Publication No. 2011/0289869, entitled "Thermally Insulating Fenestration Devices and Methods,".

[0077] The tubular daylighting device can include a thermal break in any materials or components of the daylight device that have high thermal conductivity. For example, a spacer or gap in the sidewall of the tube can be positioned near a thermal insulating portion and the thermal insulating portion and thermal break can be configured to form a substantially continuous layer between the building interior and the exterior environment. In certain embodiments, the insulating portion and thermal break are disposed in the same plane as other building insulation material, such as fiberglass or the like.

[0078] FIG. 5 illustrates an embodiment of a daylighting device 500 incorporating a collimator 530 at a bottom, or terminal portion of the daylighting device 500. The bottom portion of the daylighting device 500 can include one or more light diffusing or spreading devices 540, thermal insulation devices, or combination of devices referenced herein. Collimator 530 represents an embodiment of the collimator 130 shown in FIG 1. The collimator 530 serves to generally align rays of light propagating through the daylighting device 500 so that light reaches the diffuser 540 at greater angles with respect to the base of the diffuser 540 than it would without a collimator. The collimator 530 can be a multi-segment, or multi-stage, collimator. In some embodiments, the collimator 530 is a single-stage collimator. In certain embodiments, sunlight entering the tube will have a solar altitude (angle from the horizon) that will remain substantially the same as it reflects down the tube when the tube sides are vertical and parallel. Installation of a collimator, such as a flared out reflective tube, at or near the base of a tube 520 with the diffuser attached to the base may substantially reduce the incident angle of light to the diffuser, which may increase the diffuser optical efficiency and other system performance characteristics.

[0079] The daylighting device 500 includes a light collector 510 having a height h_c . As used herein, the height h_c may refer to the height of a substantially vertical sidewall portion of the collector 510. For example, the substantially vertical sidewall portion may provide a vertical daylight-collection surface for daylight incident on certain portions of the collector 510. The light collector 510 can be disposed about, or adjacent to, the tube 520, which extends through an opening 529 in a building. The opening 529 has a width w_o ; the tube 520 has a width w_t . The opening of the tube or the opening 529 of the building may provide a target area into which light can be directed by the light collector 510 or otherwise received into the daylighting system 500. In certain embodiments, the height h_c of the light collector 510 is greater than the width w_o of the opening 529, and/or width w_t of the tube/target area. For example, the daylighting installation 500 can include, a light collector 510 configured such that the height of the light collector h_c is approximately 1.2 to 2.5 times greater than the width w_t . That is, the height of the light collector h_c has an aspect ratio of approximately 0.5-2.75, 1.1-2.1, or 1.2:1 to 2.1:1 with respect to the width w_o of the opening 529. In certain embodiments, the aspect ratio is greater than 2.5:1. In certain embodiments, the width w_t of the tube 520 is approximately 53.3 centimeters, and the width w_o of the opening 529 is greater than, or approximately equal to, the width w_t of the tube 520. In certain embodiments, the light collector 510 has a width w_c of approximately 58.4 centimeters, a height h_c of approximately 91.4 centimeters and a collimator 530 terminating in a base having a width of approximately 78.7 centimeters.

[0080] FIG. 6 illustrates an embodiment of the light collector 110 shown in FIG. 1. In certain embodiments, the light collector is configured to turn at least a portion of the light L_D striking one of its surfaces such that the light is directed downwardly toward a horizontal aperture of a tube 620. Various features and characteristics of the light collector 610 affect the light turning properties of the collector. As disclosed in U.S. Patent No 7,546,709, the entire contents of which are incorporated by reference and made a part of this specification, a transparent cover including a smooth outside surface in combination with an internal prismatic element may produce desirable light-turning effects. In certain embodiments, such a configuration provides a double refraction of the sunlight incident on an outside surface of the collector 610. The collector 610 can be configured to have a continuous curved shape with respect to one or more dimensions, or may have a series of curved and/or flat surfaces.

[0081] The light collector 610 illustrated in FIG. 6 includes a top surface 612 and one or more side surfaces 614. The top surface 612 can be substantially flat, as shown, or have a slope substantially near zero. Such a configuration may increase an incident angle of light striking the top portion 612, which may contribute to higher refraction and/or transmission values. In certain embodiments, both the top surface 612 and one or more side surfaces are associated with light turning characteristics. The sidewall portion 614 of the collector 610 may present a vertical daylight-collection surface through which daylight may enter the daylighting device 600. As shown, daylight L_{Ds} may enter the collector 610 through sidewall 614 at a solar altitude θ_i . Light turning characteristics associated with the sidewall 614 may turn light L_{Ds} in a direction towards a target area 618, such as an opening in the tube 620, or other building opening. Turning can be achieved

through prismatic characteristics of the collector wall or prismatic element or sheet, or other optical element, in association with the sidewall 614. In certain embodiments, the resultant solar altitude θ_2 of L_{DS} is greater than that of θ_1 . In certain embodiments, an aspect ratio between the height of the collector 610 and the width or diameter of the relevant target area is optimized to improve performance.

5 **[0082]** Light turning features of the light collector 610 can include prismatic patterns formed on a surface of the collector 610. Such a pattern can be, for example, molded into the inside and/or outside surface of the collector 610. The pattern can be formed by any suitable method, such as by using a casting, or injection molding technique. In certain embodiments, a prismatic element, or other prismatic structure, is adhered to, connected to, or otherwise associated with the collector 610. In certain embodiments, the prisms can be established by horizontal grooves that are defined by opposed faces that may have a flat or curved cross-sectional shape. Furthermore, as disclosed further below, grooves can vary in depth and pitch and/or in other respects. Examples of prismatic structures are illustrated in FIGS. 13A-C. Prisms may circumscribe the entire circumference of the collector 610, and can be substantially uniform throughout the height or circumference, or perimeter, of a portion of the collector 610. In certain embodiments, prisms/grooves vary with respect to one or more parameters at different heights or points along the circumference of the collector 610. For example, prisms can include faces of varying angles, shapes, and/or widths, depending on height and/or position. In certain embodiments, portions of the collector 610 are not associated with prismatic structure.

10 **[0083]** The top portion 612 of the collector 610 can be associated with light turning characteristics. For example, as shown, light L_{DT} entering the collector 610 through top portion 612 can be turned in a direction towards the tube opening 618, or opening in a building, such that a resulting solar altitude of the light L_{DT} has a solar altitude of θ_3 . In certain embodiments including optical turning elements associated with both a top portion 612 and a sidewall portion 614, the resultant solar altitude θ_3 , of the top portion 612 is greater than the resultant solar altitude θ_2 of the sidewall portion 614. That is, light L_{DT} striking the top portion 612 can be turned to a greater degree than light L_{DS} striking the side portion 614. In certain embodiments, the top portion 612 does not include a prismatic structure or light-turning characteristics. In certain embodiments, the sidewall portion 612 does not include a prismatic structure or light-turning characteristics. For example, the top portion can include a clear acrylic surface that is substantially optically transparent. In certain embodiments, the top portion is at least partially optically opaque, or reflective. Such qualities can be desirable in order to reduce the amount of light transferred through the collector 610 into the tube 620 at various points during the day, such as during the middle of the day when sunlight levels are relatively intense.

20 **[0084]** The tube 620 can be a separate component of the day lighting device 600 than the light collector 610. For example, the tube can be an internally reflective channel of rigid construction, such as having a construction of aluminum and/or other material that is disposed adjacent to, or connected to, the light collector 610. In certain embodiments, the tube 620 and the collector 610 are integrated such that the two components substantially combined into a single structure.

25 **[0085]** FIG. 7 illustrates an embodiment of a daylighting system 700 including a light collector with a dome-shaped top portion 712. The dome-shaped top portion 712 may present a surface that is angled (θ) at various points with respect to a horizontal plane. Such an angle θ may affect the refractive characteristics of the top portion 712, and may vary along the surface of the top portion 712.

30 **[0086]** The top portion 712 can include any suitable shape. For example, FIG. 8 illustrates an embodiment of a daylighting system 800 with a top portion 812 having an angled cross-section. The cross-section of FIG. 8 may, for example, correspond to a light collector having a top portion 812 that is angled at 0-10 degrees from horizontal, 10-20 degrees from horizontal, 20-30 degrees from horizontal, 0-20 degrees from horizontal, 0-30 degrees from horizontal, or at any angle in between. The shape, and/or size of the light collector 810 and/or top portion 812 may depend on various system considerations, such as ease of manufacturing/installation, refractive characteristics, aesthetics, and or other considerations. Any suitable shape or size of the top portion (e.g., 712, 812) can be used in daylighting devices constructed or configured according to one or more embodiments disclosed herein.

35 **[0087]** Though generally illustrated herein as having a cylindrical, or oval-shaped cross-section in certain embodiments, a light collector in accordance with the present disclosure may have any suitable cross-sectional shape. Furthermore, the cross-sectional shape of a light collector may vary at different points along a vertical axis of the light collector. FIGS. 9A-9F illustrate embodiments of light collectors having various cross-sectional shapes. The various shapes shown in FIGS. 9A-9F include square or rectangular 910A, hexagonal 910B, elliptical or oval-shaped 910C, triangular 910D, octagonal 910E, and pentagonal 910F light collectors. However, the embodiments depicted are provided as examples only, and a light collector for use in a daylighting system as described herein can be any suitable or feasible shape and/or size. Various shaped light collectors can be configured to correspond to a shape of a building opening through which a daylighting device transmits light. Prismatic elements can be positioned on one or more surfaces or zones of the light collector. As one example, FIG. 9A illustrates prismatic elements on a top surface and a front surface of the light collector.

40 **[0088]** FIGS. 10A-D show cross-sectional views of a light collector 1010 including both a side portion 1014, and a top portion 1012. The collector 1010 can include a transparent acrylic material, or other material that is at least partially transparent. In certain embodiments, the collector 1010 can be manufactured at least partially of transparent acrylic

having a thickness of approximately 100-125 mm. In certain embodiments, one or more prismatic elements 1015a/1015b are disposed within or without the side portion 1014 and/or the top portion 1012, which may provide double refraction of light. FIGS. 10A-D illustrate various configurations of prismatic elements 1015a associated with the side portion 1014 and prismatic elements 1015b associated with the top portion 1012. For example, as illustrated in FIG. 10A, the prismatic element 1015a is associated with the side portion 1014 and prismatic element 1015b is associated with the top portion 1012. The prismatic element 1015a extends along at least a portion 1017 of the side portion 1014 of the collector 1010. The prismatic elements 1015a and 1015b can include a non-prismatic (e.g., planar) side and a prismatic side.

[0089] In certain embodiments, the prismatic element is molded into a thin polymer sheet that can be placed inside a protective transparent collector structure. The sheet can be molded to include various prismatic patterns. Various embodiments of prismatic patterns are illustrated in FIGS. 13A-C. The top portion 1012 can include a variable prism dome. In some embodiments, the prismatic elements 1015a and/or 1015b can be incorporated into one or more walls or surfaces of the collector 1010 by forming prismatic features into the one or more walls or surfaces of the collector 1010. While such formed prismatic features can be used, in certain embodiments, a prismatic element may provide desirable light turning characteristics relatively more efficiently, with respect to cost, ease of manufacture, and/or other considerations.

[0090] In certain embodiments, the side portion 1014 is cylindrically shaped, providing a 360-degree sunlight capture zone. The effective light capture area of the side portion 1014 can be an area of a cylinder in direct exposure to rays of sunlight, as well as a portion of the top cover 1012 that is directly exposed to the sunlight. In certain embodiments, in the presence of unobstructed, substantially collimated light, the effective capture area of the side portion 1014 can be approximately 90 degrees of the 360 degree circumference of the side portion 1014, or approximately 25% of the total surface area of the side portion 1014.

[0091] In certain embodiments, the prismatic element 1015a, with either outwardly-facing or inwardly-facing prisms, extends along the inside of at least a portion 1017 of the side portion 1014 of the collector 1010. In certain embodiments, sunlight may refract down into the tube if the sunlight is within approximately +/- 45 degrees incident angle to the surface of the side portion 1014 of the collector. The side portion 1014 can be hollow, and may extend from the top portion 1012 down, terminating in an open lower end 1018, through which light can pass.

[0092] In certain embodiments, the light collector 1010 can be configured such that optical elements associated with the side portion 1014 capture sunlight having elevations ranging from 20°-40°, while optical elements associated with the top portion 1012 capture incident light at solar elevations greater than approximately 45°. By capturing sunlight incident at a wide range of solar altitudes, the optical elements of the light collector 1010 can substantially enhance the light collection performance of the daylighting device 1000 over a wide range of latitudes and seasons.

[0093] As shown in FIG. 10A, the light collector 1010 can include one or more prismatic elements 1015a, which extend across at least a segment 1017 of a height and a perimeter of the side portion 1014. The prismatic element 1015a can be a single unitary member, or can include multiple distinct segments. In certain embodiments that include a prismatic element 1015a, the prismatic element 1015a can span the entire perimeter of the side portion 114 of the light collector 1010. Alternatively, as shown in FIG. 10, the prismatic element 1015a can span a segment 1017 of the perimeter of the side portion 1014, but not span a remaining perimeter segment that is contiguous to the spanned segment 1017.

[0094] In certain embodiments, the prismatic elements 1015a and/or 1015b can include prisms configured to refract light. The prismatic elements 1015a and/or 1015b can have a prismatic surface including a plurality of prisms and a non-prismatic (e.g. planar surface) opposite the prismatic surface. The plurality of prisms can include prism grooves on the prismatic surface of the prismatic element. In certain embodiments, the grooves can be linear when the prismatic element 1015a is in a flat configuration and, thus, form circles when the prismatic element 1015a is formed into a cylindrical configuration.

[0095] The outer surface of the prismatic element can be positioned against, or proximate to, an inner surface of the sidewall portion of the collector. The prism grooves can be outwardly facing, as shown in FIG. 10A, or otherwise configured. In certain embodiments, similar prisms are present in both the top portion and the side portion, both serving to increase light throughput. The various prism elements included in the light collector 1010 can have different prism angles, depending on what portion of the collector 1010 they are associated with. In certain embodiments, the prismatic elements in the light collector 1010 have uniform prism angles throughout the collector 1010. In certain embodiments, prisms within a single region of the collector 1010 have varying prism angles. As one example, the prisms can have variations in the prism angles along the length of the prism. For example, it can be desirable for adjacent prisms, or adjacent groups of prisms, to include different prism angles in order to mix the light that propagates through a portion of the light collector 1010. For example, if substantially collimated light enters a prismatic portion of a light collecting assembly that includes prisms with equal prism angles, light entering the tube can be concentrated in certain regions. Such light concentration may cause undesirable "hot spots" in the destination area. By varying the prism angles, the effect of such hot spots can be reduced. In certain embodiments, the prisms can be continuous or have separated spaces between the prisms. In certain embodiments, the prisms can have flat or partially curved faces.

[0096] The top portion 1012 can be made integrally with the side portion 1014 and may extend from an open base 1018 to a closed top portion 1012, forming a continuous wall. Alternatively, the top portion 1012 can be an at least

partially separate physical component from the side portion 1014. In the depicted embodiment, the top portion 1012 is substantially flat, and can be associated with one or more optical components, such as a prismatic element 1015b. However, as discussed above, the top portion 1012, or any other portion of the light collector 1010, can be shaped in any suitable manner. For example, the top portion 1012 can be angled such as illustrated in FIG. 8.

5 **[0097]** In certain embodiments, the top portion 1012 is at least partially constructed of transparent acrylic. In certain embodiments, the top portion 1012 can be formed with prismatic elements, which can be prism lines that are etched in, molded in, or otherwise integrated with or attached to the top portion 1012. In certain embodiments, the prism elements increase light throughput by capturing light originating outside the collector 1010 and turning it downward through the open base portion 1018, and into a tube assembly. Prismatic elements 1015b associated with the top portion 1012 may differ from the prismatic elements 1015a associated with the side portion 1014. For example, the prismatic element 1015b can include prismatic grooves having opposing faces that lie at angles of approximately 70° and 30°, respectively, with respect to a vertical plane. In some embodiments, the angles can be approximately 45° and 18°. Prisms including faces that lie at other angles are also contemplated with respect to embodiments of top, side, and/or other portions of light collecting assemblies disclosed herein.

10 **[0098]** FIG. 10A illustrates an embodiment of a configuration of the prismatic elements 1015a and 1015b within the light collector 1010. The prismatic surface of the prismatic element 1015a can be positioned against, or proximate to, an inner surface of the side portion 1014 of the collector 1010. The prism grooves of the prismatic surface can be outwardly facing towards the direction of incoming light. The non-prismatic surface of the prismatic element can be opposite the prismatic surface and can be inwardly facing toward the interior of the light collector 1010. The outwardly facing prismatic surface of the prismatic element 1015a can provide a first refraction of light and the non-prismatic surface of the prismatic element 1015a can provide a second refraction of light toward the aperture 1018. A detailed view of the prismatic element 1015a in this configuration is illustrated in FIG. 11A.

15 **[0099]** The prismatic surface of the prismatic element 1015b can be positioned against, or proximate, an inner surface of the top portion 1012. In some embodiments, the prismatic element 1015b can be molded into the top portion 1012. The non-prismatic surface of the prismatic element 1015b can be upwardly or outwardly facing towards the direction of incoming light. The prism grooves of the prismatic surface of the prismatic element 1015b can be downwardly or inwardly facing toward the interior of the light collector. The outwardly facing non-prismatic surface of the prismatic element 1015b can provide a first refraction of light and the prismatic surface of the prismatic element 1015b can provide a second refraction of light toward the aperture 1018.

20 **[0100]** FIG. 10B illustrates an embodiment of a configuration of the light collector 1010 including the prismatic element 1015b' associated with the top portion 1012. In this embodiment, there is no prismatic element associated with the side portion 1014. In this embodiment, the non-prismatic surface of the prismatic element 1015b' can be positioned against, or proximate, an inner surface of the top portion 1012. The prismatic element 1015b can be offset from the inner surface of the top portion 1012 so that the prismatic element 1015b' does not directly contact the inner surface of the top portion 1012. The non-prismatic surface of the prismatic element 1015b' can be positioned towards the direction of incoming light. For example, as illustrated, the non-prismatic surface of the prismatic element 1015b' can be upwardly or outwardly facing. The prism grooves of the prismatic surface are positioned on the opposite side from the non-prismatic surface. For example, as illustrated, the prismatic surface can be downwardly or inwardly facing toward the interior of the light collector 1010. The non-prismatic surface of the prismatic element 1015b' can provide a first refraction of light and the prismatic surface of the prismatic element 1015b' can provide a second refraction of light toward the aperture.

25 **[0101]** FIG. 10C illustrates an embodiment of a configuration of the light collector 1010 with a shortened sidewall 1014' as compared to FIG. 10B. The shortened sidewall 1014' can help increase that proportion of light transmitted directly through the top portion 1012 toward the collector base aperture and reduce the proportion of incoming light transmitted through the sidewall 1014 toward the collector base aperture 1018.

30 **[0102]** FIG. 10D illustrates an embodiment of a configuration of the light collector 1010 including the prismatic element 1015b' associated with the top portion 1012 and a reflector 1080 associated with at least a portion of the sidewall portion. In this embodiment, there is no prismatic element associated with the side portion 1014. The non-prismatic surface of the prismatic element 1015b' can be positioned against, or proximate, an inner surface of the top portion 1012. The prismatic element 1015b' can be offset from the inner surface of the top portion 1012 so that the prismatic element 1015b' does not directly contact the inner surface of the top portion 1012. The non-prismatic surface of the prismatic element 1015b can be positioned towards the direction of incoming light. For example, as illustrated, the non-prismatic surface of the prismatic element 1015b' is upwardly or outwardly facing. The prism grooves of the prismatic surface are positioned on the opposite side from the non-prismatic surface. For example, as illustrated, the prismatic surface can be downwardly or inwardly facing toward the interior of the light collector. The outwardly facing non-prismatic surface of the prismatic element 1015b' can provide a first refraction of light and the prismatic surface of the prismatic element 1015b' can provide a second refraction of light toward the aperture.

35 **[0103]** The reflector 1080 can be a flat or curved reflective panel associated with the light collector 1010 that reflects at least a portion of sunlight, which would otherwise exit the light collector 1010, toward the collector base aperture 1018.

The light reflector 1080 can be disposed within, adjacent to, or in integration with, a light collecting assembly. The reflector can be made of material having high luminous reflectance. For example, the luminous reflectance of the reflector 1080 can be greater than or equal to about 0.9, greater than or equal to about 0.95, greater than or equal to about 0.98, or greater than or equal to about 0.99, when measured with respect to CIE Illuminant D₆₅. The reflector 1080 can be curved, such as illustrated in FIGS. 14A-C, or can be any shape configurable to reflect light propagating within or near a light collecting assembly.

[0104] The reflector 1080 can be sloped inward by a defined slope angle α_{slope} . Sloping the reflector 1080 relative to a vertical orientation can advantageously increase the effective solar altitude by up to about twice the slope angle. For example, light incident at an angle θ on the vertical reflector can be reflected at the same angle θ . Light incident at an angle θ on a reflector sloped by an angle α_{slope} can be reflected by an amount $\theta + 2 \alpha_{\text{slope}}$. Thus, a sloped reflector can advantageously increase the effect solar altitude angle, such as, for example by twice the slope angle. Additional embodiments of reflectors that can be incorporated in the light collecting assembly are described herein.

[0105] The daylighting device 1000 can be configured as a skylight that provides illumination to the interior of a part of a building (e.g., a room of a building, lobby of a building, etc.) through an opening (e.g., a vertical opening) in the roof of the building or the attic area of the building. An example of a skylight includes a tubular daylighting device comprising a tubular light conduit and a diffusing element. Embodiments of a tubular daylighting device are described in U.S. Publication No. 2013/0083554 Other examples of a skylight can include: a fixed skylight comprising a light transmitting element fixedly positioned in a frame disposed on a top or a side of the building; a skylight comprising a light transmitting element that is hinged to a frame and is configured to be opened to allow ventilation; or a retractable skylight in which the light transmitting element can be retracted off a frame so that the interior of the building can be illuminated with ambient light and be ventilated. The light transmitting element of the skylight can include a light collector (e.g., light collector 1010) and one or more prismatic elements (e.g., 1015a, 1015b, 1015b'). The light transmitting element of the skylight can have a planar geometry or a three-dimensional geometry. For example, the light transmitting element of the skylight can be dome shaped. The light transmitting element can have a rectangular shape, circular shape, oval shape, square shape, or any other regular/irregular shape as may be dictated by architectural requirements or constraints.

[0106] With reference now to FIG. 10E, an embodiment of a configuration of a planar skylight 1100 is illustrated. Although, the skylight 1100 is illustrated as having a planar geometry, the skylight 1100 can have any other three-dimensional geometry (e.g., it can be dome shaped) in other embodiments. The skylight 1100 can have a rectangular, circular, oval or any other regular/irregular shape. The skylight 1100 can be configured so that it aligns with the angle of the roof structure of the building. Generally, the angle of the roof can be less than about 40° from horizontal. In some embodiments, the skylight 1100 can be configured so that, when installed, the skylight 1100 is parallel or substantially parallel to the roof. The skylight 1100 can be mounted directly to the roof structure. In some embodiments, the skylight 1100 can be configured to protrude from the surface of the roof structure, which can be about 15.2 centimeters or less, 7.6 centimeters or less, or another height relative to the surface of the roof. In certain embodiments, a side of the skylight 1100 closer to the pole protrudes from the roof while a side of the skylight 1100 closer to the equator does not protrude from the roof or protrudes less from the roof than the other side of the skylight 1100. The low profile of the skylight 1100 can help to reduce the visibility of the skylight 1100 when installed on the roof structure.

[0107] The skylight 1100 can include a skylight cover 1102 and a prismatic element, such as the prismatic element 1015b shown in FIG. 10E. The skylight cover 1102 can include a light collector or a glazing pane. As used herein a glazing pane refers to a transmissive portion of a fenestration apparatus. Accordingly, a glazing pane can include a transmissive portion of a wall, a window, a roof of a building. The skylight cover 1102 can have a planar or a three dimensional geometry (e.g., a dome shape). The skylight cover 1102 can have a rectangular shape, a circular shape, an oval shape or any other regular/irregular shape. The skylight cover 1102 has an outer surface configured to receive incident sunlight and an inner surface opposite the outer surface.

[0108] The prismatic element 1015b can have a non-prismatic surface that is configured to receive light transmitted through the skylight cover 1102 and a prismatic surface comprising a plurality of prisms or grooves configured to refract the received light. The non-prismatic surface can be planar (e.g., as illustrated in Figure 10E) or non-planar. In various embodiments, the non-prismatic surface of the prismatic element 1015 can have a shape that is substantially similar to the shape of the skylight cover 1102. The prismatic element 1015b can be positioned against, or proximate, the inner surface of the skylight cover 1102. In some embodiments, the prismatic element 1015b can be adhered to the inner surface of the skylight cover 1102. In some embodiments, the prisms of the prismatic element 1015b can be molded on the inner surface of the skylight cover 1102 such that the prismatic element 1015b is integrated with the inner surface of the skylight cover 1102. In some embodiments, the prismatic element 1015b can be offset from the inner surface of the skylight cover 1102 so that the prismatic element 1015b does not directly contact the inner surface of the skylight cover 1102. In such embodiments, the prismatic element 1015b can be positioned at a small distance (e.g., between about 0.025 centimeters and about 2.54 centimeter) from the inner surface of the skylight cover 1102. In various embodiments, the prismatic element 1015b can be positioned such that it is no more than 15.2 centimeters from the plane of the roof. In various embodiments, the prismatic element 1015b can be positioned below the plane of the roof. The

non-prismatic surface of the prismatic element 1015b can be positioned towards the direction of incoming light. For example, as illustrated, the non-prismatic surface of the prismatic element 1015b can be upwardly or outwardly facing. The plurality of prisms 1156b of the prismatic surface is positioned on the opposite side from the non-prismatic surface. For example, as illustrated, the prismatic surface can be downwardly or inwardly facing toward the interior of the skylight 1100. The non-prismatic surface of the prismatic element 1015b can provide a first refraction of light and the prismatic surface of the prismatic element 1015b can provide a second refraction of light toward an aperture of the skylight 1100.

[0109] The skylight 1100 can be configured so that it can be positioned on various locations on the roof, such as, for example, a north, south, east, or west facing roof. The positioning of the non-prismatic surface of the prismatic element 1015b to face the direction of incoming light can provide an angle of refraction that increases the range of solar altitudes at which radiation can be captured and turned towards the daylighting aperture at the base of the light collector.

[0110] In some embodiments, a thermally insulating section is disposed between the skylight 1100 and a thermally-controlled portion of the building that receives illumination via the skylight 1100. For example, the thermally insulating section can be disposed at the level of building insulation. Examples of thermally insulating sections are disclosed in U.S. Patent No. 8,601,757,.

[0111] With reference to FIG. 10F, another embodiment of a skylight 1110 is illustrated that can be angled relative to the slope of the roof. The embodiment of the skylight 1110 can share the same characteristics of the skylight 1100 discussed above. The skylight 1110 is angled such that the edge further from the equator is elevated relative to the opposite edge (i.e., the edge closer to the equator). For example, an elevated side may have a height of 15.2 centimeters or less relative to the roof and the opposite side may be flush with the roof or have a height that is less than the elevated side. In some embodiments, the angle of the slope relative to the plane of the roof is greater than 0°, greater than or equal to 5°, greater than or equal to 10°, greater than or equal to 15°, and can be less than or equal to 20°, less than or equal to 25°, less than or equal to 30°, less than or equal 35°, and/or within a range bounded by any two of the foregoing angles. The angle of the skylight 1110 can be configured to increase the effective area of the skylight 1110 and increase the effective solar altitude of sunlight incident on the skylight 1110.

[0112] The skylight 1100 can be positioned in a frame that is attached to an opening in a roof or in an attic area of a building. The frame can include ridges, shelves and/or grooves configured to receive the skylight cover 1100 and/or the prismatic element 1015b. The skylight 1100 can be immovably positioned in the frame or movably positioned in the frame such that it can be at least partially opened. As discussed herein, the skylight 1100 can include a tubular light conduit that allows propagation of light transmitted through the prismatic element 1015b towards an aperture of the skylight. The tubular light conduit can include various optical elements (e.g., reflectors, redirectors, diffusing elements, etc.) that are configured to condition light transmitted through the prismatic element 1015b prior to being emitted through the aperture. In various embodiments, the skylight 1100 can include a diffuser positioned to provide diffused light to the interior of the room. The diffuser may positioned near or adjacent an aperture of the skylight within the building.

[0113] Various embodiments of the skylight 1100 includes a positioning assembly that is configured to position the skylight cover 1102 over an opening in a roof of the building. The positioning assembly can be further configured to position the prismatic element 1015b at a desired orientation with respect to the plane of the roof to increase light collection efficiency by the skylight 1100.

[0114] FIG. 11A provides a cross-sectional view of a portion 1115a of the prismatic element 1015a shown in FIG. 10A. In the embodiment illustrated in FIG. 11A, the prismatic element 1115a comprises a non-prismatic surface 1149a and a prismatic surface including a plurality of prisms 1156a opposite the non-prismatic surface 1149a. The structure shown in FIG. 11A omits the outer transparent side portion 1014 of the light-collecting assembly 1010 of FIG. 10A for clarity. The prisms 1156a can be positioned along the interior surface of the side portion 1014, and may face the direction of sunlight L_S penetrating the side portion 1014. In certain embodiments, prisms 1156a are inwardly facing, with non-prismatic surface 1149a facing the side portion 1014. In certain embodiments, prismatic element 1115a can include prisms on more than one of its sides. The prisms 1156a can be configured to turn at least a portion of sunlight that strikes the sidewall portion of the light collecting assembly downward towards a horizontal aperture of a tube.

[0115] In certain embodiments, prisms 1156a include two surfaces - a draft surface 1146a and a riser surface 1148a. In the embodiment of FIG. 11A, riser surface 1148a has a prism riser angle γ_1 with respect to a normal to the non-prismatic surface 1149a, while the draft surface 1146a has a prism riser angle γ_2 with respect to the normal to the non-prismatic surface 1149a. The prism angles γ_1 and γ_2 can be equal, or may vary, depending on the configuration of the prismatic element 1115a. Furthermore, adjacent prisms 1156a, or groups of prisms, may have varying prism angles. Such varying prism angles may promote mixing of light propagating through a light collector. In certain embodiments the prismatic element 1115a includes prisms having uniform prism angles. In certain embodiments, the prism angles γ_1 and γ_2 have angles of approximately 70° and 30°, respectively.

[0116] FIG. 11B provides a cross-sectional view of a portion of the prismatic element 1015b shown in FIGS. 10A-G, the illustrated portion of the prismatic element is referred to as 1115b. The structure shown in FIG. 11B omits the outer transparent top portion 1012 of the light-collecting assembly 1010 illustrated in FIGS. 10A-D and the skylight cover 1102 illustrated in FIG. 10E for clarity. The prismatic element 1115b includes a non-prismatic surface 1149b on a first side

and a prismatic surface comprising plurality of prisms 1156b on a second side. The non-prismatic surface 1149b can be planar in various embodiments. The prismatic element 1115b can be positioned along the interior surface of the top portion 1012. The non-prismatic surface 1149b of the prismatic element 1115b can be configured to face the top portion 1012 or the skylight cover 1102, and may face the direction of sunlight L_S penetrating the top portion 1012 or the skylight cover 1102. The non-prismatic surface 1149b can provide a first refraction of sunlight L_S and the prisms 1156b can provide a second refraction of sunlight L_S in order to turn at least a portion of sunlight that strikes the top portion of the light collecting assembly downward towards a horizontal aperture of a tube.

[0117] Each of the prisms 1156b can include two surfaces - a riser surface 1146b, and a draft surface 1148b. In the embodiment of FIG. 11B, the riser surface 1146b is inclined by a riser prism angle γ_1 with respect to a surface normal to the non-prismatic surface 1149b, while the draft surface 1148b is inclined by a draft prism angle γ_2 with respect to a surface normal to the non-prismatic surface 1149b, the draft prism angle γ_2 being opposite the riser prism angle γ_1 . The inclination of the riser surface is provided by the riser prism angle γ_1 and the inclination of the draft surface is provided by the draft prism angle γ_2 . The plurality of prisms 1156b included in a skylight 1100 can be oriented such that the riser surface 1146b faces the equator. For example, in the northern hemisphere the riser surface 1146b can be oriented to face south. Orienting the riser surface 1146b of each of the plurality of prisms 1156b toward the equator can increase the efficiency of light collection by the skylight 1100. The size of the riser surface 1146b and the inclination of the riser surface given by the riser prism angle γ_1 with respect to the surface normal to the non-prismatic surface 1149b can be configured to increase collection of sunlight for various times of the day and/or year. In various embodiments of the skylight 1100, the size, inclination, and the orientation of the riser surface 1146b can be configured such that a substantial portion of the sunlight transmitted through the non-prismatic surface 1149b of the prismatic element 1115b can be incident on the riser surface 1146b throughout the day (e.g., morning and evening when the rays of the sun are oblique and noon when the rays of the sun are less oblique) and/or year (e.g., spring, summer, autumn and winter). For example, greater than about 50% of the received sunlight, greater than about 60% of the received sunlight, greater than about 70% of the received sunlight, greater than about 80% of the received sunlight, greater than about 90% of the received sunlight, or greater than about 95% of the received sunlight can be incident on the riser surface 1146b. In such embodiments, the amount of sunlight transmitted through the non-prismatic surface 1149b of the prismatic element 1115b that is incident on the draft prism surface 1148b can be less than or equal to about 10%, less than or equal to about 20%, less than or equal to about 30%, less than or equal to about 40%, etc. In various embodiments discussed herein, the riser surface 1146b can be configured to face the sun such that the amount of incident sunlight transmitted through the non-prismatic surface 1149b received by the riser surface 1146b is greater than the amount of incident sunlight transmitted through the non-prismatic surface 1149b received by the riser surface 1148b.

[0118] In the embodiment illustrated in Figure 11B, the size and the riser angle of the riser surface 1146b is configured such that sunlight incident at less oblique angles as well as more oblique angles are received by the riser surface 1146b and refracted out of the prismatic element 1115b. For example, sunlight incident at an angle of 20 degrees with respect to the non-prismatic surface 1149b of the prismatic element 1115b depicted by ray L20 is received by the riser surface 1146b and refracted out of the prismatic element 1115b at an angle of about 40-45 degrees with respect to non-prismatic surface 1149b as depicted by ray R45. Sunlight incident at an angle of 60 degrees with respect to the non-prismatic surface 1149b of the prismatic element 1115b depicted by ray L60 is also received by the riser surface 1146b and refracted out of the prismatic element 1115b at an angle of about 70-75 degrees with respect to the non-prismatic surface 1149b as depicted by ray R72. Sunlight incident at an angle of 90 degrees with respect to the non-prismatic surface 1149b is refracted out of the is also received by the riser surface 1146b and refracted out of the prismatic element 1115b at an angle of about 100-105 degrees with respect to the non-prismatic surface 1149b as depicted by ray R101.

[0119] The prism angles γ_1 and γ_2 can be equal, or may vary, depending on the configuration of the prismatic element 1115b. Furthermore, adjacent prisms 1156b, or groups of prisms, may have varying prism angles. Such varying prism angles may promote mixing of light propagating through a light collector. In certain embodiments the prismatic element 1115b includes prisms having uniform prism angles. In certain embodiments, the prism angles γ_1 and γ_2 have angles of approximately 70° and 30°, respectively. In certain embodiments γ_1 can have angles between 60° and 90°, between 60° and 80°, between 65° and 75°, between 67° and 73°, or another acceptable range. In certain embodiments γ_2 can be between 20° and 40°, between 25° and 35°, between 27° and 33°, or another acceptable range. In some embodiments, the performance of the efficiency of light collection by the light collector 1010 and/or the skylight 1100 can be improved when the prism angle γ_1 , also referred to as the riser angle, is between 30° and 85°, between 35° and 75°, between 40° and 70°, between 45° and 65°, or between 50° and 60°. For example, in various embodiments, the prism angle γ_1 can have a value between about 35 degrees and about 43 degrees. As another example, the prism angle γ_1 can have a value between about 47 degrees and about 85 degrees. In some embodiments, the prism angle γ_1 can be approximately equal to 50°.

[0120] With further reference to FIGS. 10A-D, prism angles associated with the top portion 1012 and the side portion 1014 can be selected to provide an angle of refraction that increases the range of solar altitudes at which radiation can be captured and turned towards the daylighting aperture 1018 at the base of the light collector 1010. In certain embod-

EP 3 516 129 B1

iments, the light collector 1010 and prismatic element are made of the same material or materials, or materials having substantially similar indexes of refraction. In some embodiments, the prismatic element(s) can include a material or materials with higher index of refraction than a sidewall of the light collector.

[0121] With specific reference to FIGS. 10B-10E, positioning of the non-prismatic surface of the prismatic element 1015b to face the direction of incoming light can provide an angle of refraction that increases the range of solar altitudes at which radiation can be captured and turned towards the day lighting aperture at the base of the light collector. The positioning of the non-prismatic surface can provide large incident angles at low solar elevations in order to produce large refraction angles. The positioning of the non-prismatic surface can be configured such that the sunlight is substantially perpendicular to the riser angle of the prismatic surface for at least a portion of the day.

[0122] Table A-1 below illustrates the adjusted solar elevation θ_3 of sunlight incident at various solar elevations θ_1 on a horizontal acrylic prismatic element with various prism angles γ_1 , also referred to as the riser angle. The adjusted solar elevation θ_3 refers to the angle of daylight after refraction by the prismatic element 1015b when the prismatic element associated with the top cover of the daylight collector is positioned with the non-prismatic surface facing outward (i.e., the non-prismatic surface is disposed between the prismatic surface and the sky) as illustrated in FIGS. 10A-10E. Table A-1 illustrates various calculated values of the adjusted solar elevation θ_3 for a prism angle γ_1 between 35 degrees and 80 degrees. For example, when prism angle γ_1 is equal to 50 degrees, incident light at solar elevation up to 90 degrees can be refracted out of the prismatic element 1015b while also providing significant increase in the adjusted solar elevation θ_3 between 20 degrees to 70 degrees.

[0123] When selecting the solar elevation θ_1 in Table A-1 the slope of the roof (also referred to as roof pitch) and any incline of a prismatic element from a plane of the roof can be accounted for as follows. If the prismatic element is parallel to the ground, the solar elevation θ_1 selected can be the actual solar elevation. When using Table A-1 for determining the adjusted solar elevation after refraction by a prismatic element not parallel to the ground, an "effective solar elevation" can be used for the solar elevation θ_1 . For example, when the prismatic element is in a plane parallel to the roof, the effective solar elevation can be obtained by adding the equator-facing roof pitch component to the actual solar elevation if the prismatic element is parallel to a roof section angled towards the equator. The effective solar elevation can be obtained by subtracting the polar-facing roof pitch component from the actual solar elevation if the prismatic element is parallel to a roof section angled away from the equator. The effective solar elevation can be further adjusted if the prismatic element 1015b is inclined from the plane of the roof. For example, if the prismatic element is inclined from the roof pitch towards the equator side of the roof (as shown in FIG. 10F), the effective solar elevation can be obtained by adding or subtracting the roof pitch component as discussed above and adding the angle between the prismatic element and the plane of the roof. The prismatic element 1015b can be installed within a light collector, such as light collector 1010, along or substantially along a horizontal plane parallel to the ground or can have a slope of up to about 40 degrees from a horizontal plane parallel to the ground. The prismatic element 1015b can be installed within a light collector, such as light collector 1010, along or substantially along a plane parallel to the plane of a roof of a building.

[0124] In some embodiments, a light collector having a prismatic element with a prism riser angle γ_1 between 35 degrees and 85 degrees can allow for a higher aspect ratio of a daylight collector, improved light collection at lower solar altitudes, increased light collection, and/or improved illumination performance.

Table A-1: Adjusted Solar Elevation (θ_3)°

Riser Angle (γ_1)	Solar Elevation (θ_1)°										
	20°	30°	40°	50°	60°	70°	80°	90°	100°	110°	120°
35°	63.2°	68.5°	75.8°	85.1°	97.5°	-	-	-	-	-	-
40°	60.4°	65.4°	72.3°	80.8°	91.2°	105.1°	-	-	-	-	-
45°	57.7°	62.7°	69.2°	77.3°	86.8°	98.2°	113.6°	-	-	-	-
50°	55.2°	60.1°	66.5°	74.2°	83.2°	93.5°	105.7°	123.3°	-	-	-
55°	52.8°	57.6°	64.0°	71.5°	80.1°	89.8°	100.7°	113.7°	134.5°	-	-
60°	50.3°	55.2°	61.5°	68.9°	77.4°	86.6°	96.8°	108.2°	121.9°	-	-
65°	47.7°	52.7°	59.1°	66.5°	74.8°	83.8°	93.5°	104.1°	115.7°	130.1°	-
70°	45.0°	50.0°	56.5°	64.0°	72.3°	81.0°	90.6°	100.6°	111.3°	123.2°	137.9°
75°	41.9°	47.2°	53.9°	61.5°	69.9°	78.7°	88.0°	97.7°	107.8°	118.5°	130.2°
80°	38.3°	44.0°	51.0°	58.9°	67.4°	76.3°	85.5°	95.0°	104.7°	114.8°	125.2°

EP 3 516 129 B1

[0125] Table A-2 below illustrates the angle of the solar elevation of sunlight incident θ_1 on a horizontal acrylic prismatic element with prism angles γ_1 and γ_2 of 70° and 30°, respectively, and the adjusted solar elevation θ_3 after refraction by the prismatic element 1015b when the prismatic element associated with the top cover of the daylight collector is positioned with the non-prismatic surface facing outward as illustrated in FIGS. 10A-10D. Adjusted efficiency is the percentage of light refracted by the prismatic element that exits the prismatic element at or near the adjusted solar elevation rather than being reflected or absorbed by the prismatic element.

Table A-2

Solar Elevation (θ_1)°	Horizontal Prismatic Element Adjusted Solar Elevation (θ_3)°	Adjusted Efficiency (%)
20.0°	41.0°	85.0%
30.0°	46.6°	90.0%
40.0°	53.7°	95.0%
50.0°	61.8°	98.0%
60.0°	70.8°	93.0%
70.0°	80.2°	88.0%
80.0°	90.1°	83.0%
90.0°	100.8°	77.0%

[0126] Table B below illustrates an the angle of the solar elevation of sunlight incident θ_1 on horizontal and vertical polycarbonate prismatic elements and the adjusted solar elevation θ_3 after refraction by the horizontal prismatic element 1015b when the prismatic element is positioned with the non-prismatic surface facing outward as illustrated in FIGS. 10A-D. Table B also shows the adjusted solar elevation θ_3 after refraction by the vertical prismatic element 1015a when the prismatic element is positioned with the non-prismatic surface facing inward as illustrated in FIG. 10A. In this embodiment, the prism angles γ_1 and γ_2 have angles of approximately 70° and 30°, respectively.

Table B

Solar Elevation (θ_1)°	Horizontal Prismatic Element Adjusted Solar Elevation (θ_3)°	Vertical Prismatic Element Adjusted Solar Elevation (θ_3)°
20.0°	44°	33°
30.0°	49°	45°
40.0°	56°	58°
50.0°	64°	80°
60.0°	73°	TIR @ 52° (θ_1)
70.0°	82°	TIR

[0127] Table C illustrates the angle of the solar elevation of the light incident θ_1 on a prismatic hemispherical dome made of acrylic, the adjusted solar elevation θ_3 after the refraction of the prismatic dome when the prismatic element is positioned with the non-prismatic surface facing the direction of incoming light and the prismatic surface facing inward.

Table C

Solar Elevation (θ_1)°	Acrylic Hemispherical Prismatic Dome Adjusted Solar Elevation (θ_3)°	Adjusted Efficiency (%)
20.0°	36.0°	85.0%
30.0°	40.0°	85.0%
40.0°	51.0°	86.0%
50.0°	56.0°	85.0%

EP 3 516 129 B1

(continued)

5
10

Solar Elevation (θ_1)°	Acrylic Hemispherical Prismatic Dome Adjusted Solar Elevation (θ_3)°	Adjusted Efficiency (%)
60.0°	61.0°	62.0%
70.0°	54.0°	46.0%
80.0°	50.0°	40.0%
90.0°	45.0°	35.0%

15
20
25

[0128] The prismatic element 1015b uses the non-prismatic side of the lens to provide large incident angles at low solar elevations in order to produce large refraction angles. The riser angle γ_1 is configured to help to minimize optical losses and maintain a downward trajectory of light due to shallow negative incident angles at low solar elevations and small positive incident angles at higher solar elevations. The draft angle γ_2 is configured to minimize the blockage of light in the downward direction throughout all solar elevations. The resultant total light turning performance is increased over a wide range of solar elevations.

[0129] The efficiencies of the prismatic element 1015b configured as illustrated in FIGS. 10A-D as compared to typical values for a prismatic hemispherical dome design are listed in Table A-2 and Table C, respectively. This adjusted solar elevation and associated efficiency combination over a range of 20 to 90 degrees is substantially greater in the configuration of prismatic element 1015b.

[0130] Table D provides example configurations for a number of possible embodiments of daylight collectors. The configurations provided in Table D correspond to the performance data shown in FIG. 25. Table D provides configuration and size information that can be helpful in assessing performance issues associated with the respective embodiments, as well as other embodiments.

Table D

30
35
40

Collector Type	Collector Height h_c (inches)	Vertical Lens Height (inches)	Reflector	Top Cover Configuration
Low Profile (LP)	6.5"	3"	None	Flat
Medium Profile (MP)	8.5"	None	Yes	Flat
High Profile (HP)	13.0"	4.5"	Yes	Flat
Medium Profile (MP)	8.5"	None	Yes	20° Slope
High Profile (HP)	13.0"	4.5"	Yes	20° Slope

45
50
55

[0131] The configurations and values provided in Table D are illustrative of various possible daylight collector configurations, and do not limit the scope of the disclosure in any way. Furthermore, although certain configurations are provided in the table, the respective collector configurations and dimensions need not conform in any way to such values, and can be configured to be any suitable combinations of configurations and dimensions.

[0132] In the tested configurations, each collector is substantially cylindrical with a width w_c of 25.4 centimeters. The table provides a collector height h_c . The vertical lens height refers to the height of a vertical prismatic element disposed within the light collector, such as illustrated in FIG. 10A. The reflector column indicates whether a reflector (e.g., reflector 1480) is included within the light collector. The top cover configuration indicates the shape of the top portion of the light collector. A flat configuration refers to the configuration of the top portion 1012 illustrated in FIGS. 10A-10D. A sloped configuration refers to a sloped top portion, such as, for example, the sloped top portion 812 illustrated in FIG. 8. In the illustrated embodiment, the slope of the top portion is 20° from horizontal. Embodiments of sloped top portions can have other suitable slopes, such as, for example, 15-25° from horizontal, 10-30° from horizontal, or 5-35° from horizontal. In some embodiments, a sloped top portion has a slope from horizontal less than or equal to 40°.

[0133] With additional reference to FIG. 25, a chart showing performance data associated with the collectors identified in the Table D is shown. The baseline performance is based on an acrylic prismatic hemispherical dome, indicated by "Dome". The chart illustrates relative performance based on the lumens of light measured at each solar altitude.

[0134] In certain embodiments, the top portion 1012 can be configured to reduce the effective capture area of the light

collector 1010 at solar altitudes higher than a certain value to prevent over illumination and/or heating during midday hours (such as, for example, between 10 am and 3 pm, between 11 am and 2 pm, or during a time when the solar altitude is greater than or equal to 50 degrees or greater than or equal to 60 degrees). In certain embodiments, at least a portion of the top portion 1012 can be configured to reflect some or all of the light striking such portion at solar altitudes above a certain angle. For example, at least some of the top portion 1012 can be configured to reflect at least a portion of overhead sunlight in order to reduce light and/or heat during midday hours. Embodiments of the light collector 1010 with a prismatic element 1015b positioned to receive daylight transmitted through the top portion 1012 can be beneficial in sunny and high solar altitude conditions. A prismatic element 1015b in the top portion 1012 can direct a substantial portion, most, or substantially all daylight incident on the top portion 1012 towards a reflector, such as, for example, the reflector 1980 shown in FIG. 19. The reflector can be configured to reject wavelengths of daylight that transmit thermal energy but provide little or no visible illumination.

[0135] In certain embodiments, the top portion 1012 of the light collector 1010 can be constructed at least partially from clear acrylic, transparent plastic, another suitable material, or a combination of materials. Embodiments of the light collector 1010 with a clear top portion can be beneficial in diffuse daylight conditions due to relatively high transmission of overhead sunlight. The prismatic elements can be constructed from an optically transparent material having a high index of refraction such as acrylic, polycarbonate, another suitable material, or a combination of suitable materials.

[0136] The walls of the side portion 1014 can be substantially vertical, or may have any desirable inward or outward slope. In certain embodiments, the walls of side portion 1014 are sloped to allow for nesting of multiple such components to allow for tighter packaging.

[0137] In certain embodiments, the side portion 1014 provides a substantially vertical daylight-collection surface for sunlight collection, which may provide higher aspect ratios for light collection. Prismatic elements can be integrated with at least a portion of the wall of the side portion 1014. In alternative to, or in addition to, prisms integrated in the side portion 1014, the above-described prismatic element can be used to refract light downward. The non-prismatic back side 1149a of the prismatic element 1115a, shown in FIG. 11A, may provide good downward refraction due to a high to low index of refraction interface. Certain light collector embodiments include a plastic polymer, such as acrylic or polycarbonate, with an index of refraction in the range of approximately 1.49-1.65. In certain embodiments, the index of refraction can be in the range of approximately 1.40 and 1.60.

[0138] Referring to Figures 10E and 10F, the embodiments of skylight 1100 can comprise a prismatic element 1015b similar to the prismatic element 1115b of Figure 11B and a light conduit configured to transmit light emitted from the prismatic surface of the prismatic element 1015b towards an output aperture of the skylight 1100. The light conduit can have a length 'l' and a width, 'd'. The inner walls of the conduit can be configured to have a reflectivity, 'r'. In various embodiments, a diffuser can be positioned adjacent the output aperture of the skylight 1100. The orientation of the riser surface of the plurality of prisms of the prismatic element 1015b can be configured to refract incident sunlight transmitted through the skylight cover 1102 and the non-prismatic surface 1149b of the prismatic element 1015b along directions that are more normal to the non-prismatic surface 1149b of the prismatic element 1015b for solar elevation angles (or solar altitude) between about 20 degrees and about 110 degrees. For example, the prism riser angle γ_1 of the riser surface of the plurality of prisms of the prismatic element 1015b can be configured to have a value between about 35 degrees and about 85 degrees such that light is transmitted out of the prismatic surface of the prismatic element 1015b along directions that are more normal to the non-prismatic surface 1149b of the prismatic element 1015b for solar elevation angles (or solar altitude) between about 20 degrees and about 110 degrees. In some embodiments, a skylight including a prismatic element 1015b can be configured to refract light such that light is transmitted out of the prismatic surface of the prismatic element 1015b along directions that are more normal to the non-prismatic surface 1149b of the prismatic element 1015b for solar elevation angles (or solar altitude) between about 20 degrees and about 110 degrees, which can improve the light collection efficiency by reducing the number of reflections through the light conduit and reduce reflection losses. Additionally, transmitting light out of the prismatic surface of the prismatic element 1015b along directions that are more normal to the non-prismatic surface 1149b of the prismatic element 1015b can advantageously improve diffusion efficiency of a diffuser disposed adjacent the aperture of the skylight 1100 and/or reduce light hotspots at the diffuser.

[0139] Figure 10G illustrates an embodiment of a skylight 1100a including a skylight cover and a prismatic element 1015b and a comparative example of a skylight 1100b including only a skylight cover and no prismatic element. Both skylights 1100a and 1100b include a conduit 1103a and 1103b configured to direct natural light between a roof and an interior of the building. The conduits 1103a and 1103b can be configured as a tube with reflective inner sidewalls, skylight wells, or other structures configured to direct natural illumination to an interior room of a building. Light entering the conduits 1103a and 1103b can be reflected by the reflective inner sidewalls to provide illumination to the interior of a building. In a particular embodiment, the conduits 1103a and 1103b each can be cylindrical having a length of about 1.83 meters and a diameter of about 25.4 centimeters. The conduits 1103a and 1103b can each have a reflectivity of about 96%. Both skylights 1100a and 1100b are disposed on a section of roof that faces the pole (e.g., on a north facing side in the northern hemisphere).

[0140] An embodiment of the skylight 1100a is positioned at 'Position C', and a comparative example of the skylight 1100b is positioned at 'Position D'. In the illustrated embodiment, the roof can have a roof pitch (corresponding to the slope of the roof) of about 20 degrees. If the solar elevation angle is 40 degrees, a ray 1106i of sunlight can be incident on the skylight 1100a at an effective solar elevation of 20 degrees with respect to a plane of the non-prismatic surface of the prismatic element 1015b as a result of the roof pitch being 20 degrees and the skylight 1100a being positioned on the pole side of the roof. The angle of incidence of ray 1106i with respect to a surface normal to the non-prismatic surface of the prismatic element 1015b at the region of incidence is 70 degrees. If the riser surface of the prismatic element 1015b is inclined at a riser angle γ_1 of about 55 degrees, then from Table A-1 it is noted that incident sunlight is refracted by the prismatic element 1015b through the prismatic surface at an adjusted solar elevation angle of 52.8 degrees with respect to the plane of the non-prismatic surface of the prismatic element 1015b. Thus, the adjusted solar elevation with respect to a horizontal plane parallel to the ground is the actual solar elevation (40 degrees) plus the adjusted solar elevation angle with respect to the non-prismatic surface of the prismatic element of light refracted by the prismatic element (52.8 degrees, from Table A-1) minus the effective solar elevation angle adjusted for the slope of the roof and/or any inclination of the prismatic element 1015b away from the plane of the roof (20 degrees). Accordingly, for the embodiment illustrated in Figure 10G, the adjusted solar elevation with respect to a horizontal plane parallel to the ground is 40 degrees + (52.8-20) degrees which is equal to 72.8 degrees. Accordingly, the refracted ray of light 1106r is emitted from the prismatic element 1015b at an angle of about 72.8 degrees with respect to a horizontal plane parallel to the ground. In contrast, ray of light 1108r that exits the comparative example skylight 1100b without the prismatic element 1015b will enter the conduit 1103b at the solar elevation, an angle of 40°. Accordingly, the presence of the prismatic element 1015b in the embodiment of the skylight 1100a advantageously increases angle at which light enters the conduit 1103a as compared to the angle at which light enters the conduit 1103b.

[0141] Because of the increased angle light, the number of reflections undergone by the ray of light 1106r that enters the conduit 1103a is lesser than the number of reflection undergone by the ray of light 1108r that enters the conduit 1103b. For example, for the embodiment illustrated in FIG. 10G, ray of light 1106r is reflected 3 times by the inner walls of the conduit 1103a before it exits the aperture of the skylight 1100a while ray of light 1108r is reflected 12 times by the inner walls of the conduit 1103b before it exits the aperture of the skylight 1100b. Accordingly, the efficiency of light transmitted through the conduit 1103a is about 88% for the embodiment of the skylight 1100a while the efficiency of light transmitted through the conduit 1103a is about 61% for the embodiment of the skylight 1100b. Various embodiments of a skylight including a skylight cover and a prismatic element can be configured to transmit light at solar elevation angles higher than the received at solar elevation angles. In contrast, embodiments of a skylight including only a skylight cover are configured to transmit light at the received solar elevation angles.

[0142] FIG. 12 shows a cross-sectional view of a light collector 1210 including a side portion that includes a plurality of vertically arranged optical zones, or segments 1214a, 1214b, and 1214c. In certain embodiments, various segments are associated with prismatic elements having different prism angles or characteristics. For example, a top segment, such as segment 1214a, can be associated with light turning structure 1213a configured to turn light at a relatively high angle towards the base 1218 of the light collector 1210. This can be desirable in order to increase the percentage of light L_1 entering the top segment 1214a that is directed through the base 1218 of the light collector 1210 and into a tube 1220. As light entering the top segment 1214a has a relatively farther distance to travel in order to reach the base 1218, it can be necessary or desirable to turn such light to a relatively high angle. Relative to the prismatic structure 1215a, the prismatic structure 1215b that is associated with the second segment 1214b can include prismatic angles that turn light L_2 to a lesser degree than L_1 is turned. This can be desirable due to the prismatic structure 1215b being disposed generally closer to the base 1218. Therefore, it may not be necessary to turn light L_2 as much to facilitate the propagation of light entering the light collector 1210 through the second segment 1214b to a desirable degree.

[0143] The light collector can include one or more portions or segments, such as segment 1214c, that are not associated with prismatic structures. For example, a segment, such as segment 1214c, disposed relatively near to the base 1218 may require relatively less turning of light, or no turning of light to achieve desirable levels of light collection. Therefore, as shown, light L_3 entering the bottom segment 1214c may enter the tube 1220 substantially without being refracted toward the tube by the light collector 1210.

[0144] Although the light collector illustrates three segments, a light collector in accordance with certain embodiments disclosed herein may contain any number of segments or regions. Furthermore, different segments can be associated with optical elements having varying characteristics, or can be uniform through one or more segments.

[0145] As shown in FIG. 12, the width w_c of the collector base 1218 can be greater than the width w_d of the tube 1220 at a horizontal aperture. For example, the diameter of the collector base 1218 may range from 100% to 150% or more of the width of the tube 1220.

[0146] FIGS. 13A-C illustrate prismatic patterns for light turning features of the light collector such as prismatic elements. The prismatic elements can be formed on a surface of the collector or on a separate film which can then be adhered to the light collector. In certain embodiments, a pattern can be molded into the inside and/or outside surface of the side portion or top portion of the light collector. The pattern can be formed by any suitable method, such as by using a casting,

or injection molding technique. In certain embodiments, a prismatic element, or other prismatic structure, is adhered to, connected to, or otherwise associated with the collector. FIG. 13A illustrates a prismatic pattern 1310a having linear or horizontal grooves. FIG. 13B illustrates a prismatic pattern 1310b having radial grooves. FIG. 13C illustrates a prismatic pattern 1310c having curve-linear and radial grooves.

5 **[0147]** The prismatic grooves can be defined by opposing prism faces. The grooves may have a flat or curved cross-sectional shape. The prism faces can vary in depth, pitch, angles, shapes, and/or widths, depending on height and/or position. The prismatic grooves can circumscribe the entire circumference of the collector, and can be substantially uniform throughout the height or circumference, or perimeter, of a portion of the collector. prisms/grooves vary with respect to one or more parameters at different heights or points along the circumference of the collector. In certain
10 embodiments, the various prism elements included in the light collector 1010 can have different prism angles, depending on what portion of the collector 1010 they are associated with. The prism angles can vary along the length of the prismatic grooves. As illustrated in FIG. 13C the prismatic pattern 1310c can have a plurality of segments of the prismatic grooves. Segments can have different prismatic patterns. In the illustrated embodiment, the prismatic pattern 1310c includes a curve-linear segment, including curved or radial grooves and linear grooves, and a radial groove segment. The prismatic
15 pattern can include gaps or separated spaces between prismatic grooves. The separated spaces can separate individual grooves and/or segments of the prismatic pattern.

[0148] In certain embodiments, the prism elements in the light collector 1010 have uniform prism angles throughout the collector 1010. In certain embodiments, prisms within a single region of the collector 1010 have varying prism angles. For example, it can be desirable for adjacent prisms, or adjacent groups of prisms, to include different prism angles in
20 order to mix the light that propagates through a portion of the light collector 1010. For example, if substantially collimated light enters a prismatic portion of a light collecting assembly that includes prisms with equal prism angles, light entering the tube can be concentrated in certain regions. Such light concentration may cause undesirable "hot spots" in the destination area. By varying the prism angles, the effect of such hot spots can be reduced.

[0149] In certain embodiments, a flat or curved reflective panel is associated with a light collector that reflects at least a portion of sunlight that would otherwise exit the light collector through a portion generally opposite to a region of the light collector through which daylight is received. FIG. 14A provides a perspective view of an embodiment of a light reflector 1480 for disposing within, adjacent to, or in integration with, a light collecting assembly. The reflector can be
25 made of material having high luminous reflectance. For example, the luminous reflectance of the reflector 1480 can be greater than or equal to about 0.9, greater than or equal to about 0.95, greater than or equal to about 0.98, or greater than or equal to about 0.99, when measured with respect to CIE Illuminant D₆₅. The reflector 1480 can be curved, as shown, or can be any shape configurable to reflect light propagating within or near a light collecting assembly.

[0150] As is shown in FIG. 14B, which provides a top view of the reflector 1480 of FIG. 14A, the reflector 1480 can be semi-circular in shape, such that it can be nested within a cylindrically-shaped light collector. The reflector 1480 may conform to the shape of a back portion of a light collecting assembly, and can be disposed behind a refractive lens,
35 thereby increasing the effecting light capture area of the light collector. The reflector 1480 may provide increased transmission of captured sunlight into an optical guide tube.

[0151] The use of a curved reflector 1480 may allow for sunlight capture from a greater range of circumferential angles about the light collector. This increase in angular reflection of sunlight may provide a number of benefits, such as increased light mixing. For example, in embodiments in which sunlight enter a tube opening from a wide range of
40 circumferential angles, the distribution of light exiting the tube can be more uniform and may reduce the presence of hot spots on a diffuser at the base of the tube. Such light mixing can prevent collimated light from reaching the diffuser prisms in such a way as to cause rainbows to appear in the building interior.

[0152] With respect to certain embodiments in which light is directed into a central feeder tube, and dispersed into multiple branch tubes, light mixing can be important in promoting the dispersion of sunlight into the various branch tubes.
45 In certain embodiments, branch tubes each receive approximately equal amounts of light from the central feeder tube.

[0153] The collection and redirection of sunlight using a light reflector, such as the curved reflector 1480, may substantially increase the performance of a conventional tubular daylighting device. A number of parameters may contribute to increased performance of certain embodiments of sunlight-collection systems. For example, the sunlight collection area of a light collector may affect the performance of such a system. In certain embodiments, the height and width of
50 the collector in relation to the diameter of a tube opening into which light is directed can be determined by the refractive turning power of optical elements (e.g., integrated prisms, prismatic element or lens film, etc.) within, or associated with, the light collector. This aspect ratio of collector height to tube opening width, or diameter, may depend on the solar altitude range that is desired to capture and refract into the tube. This range can be from approximately 20 to 70 degrees for most locations in the United States. For example, using lower-end solar altitude of approximately 20 degrees as the design point for refracting light into the tube from the optical elements associated with a light collector having vertical
55 side walls, the collector height can be designed to an approximate range of 1.2 to 2.5 times the tube diameter. These values may vary based on material index of refraction and prism angles, among other things. As an example, a system can include a collector height of approximately 88.9 - 114.3 centimeters and a tube diameter of approximately 50.8 -

63.5 centimeters. The diameter of the collector can be approximately equal to the diameter of the tube opening, or can be larger or smaller than the diameter of the tube. The actual effective front light-capture area of the collector is associated with the direct non-reflected sun, which, in certain embodiments, can be limited to an exposure angle of approximately 90 degrees due to the off axis curvature limitation of the optics in the collector prisms.

5 **[0154]** FIG. 14C provides a cross-sectional view of the vertically-oriented planar reflector 1480. As is shown in the figure, the angle θ_1 of direct light L_D with respect to a horizontal plane is generally equal to the angle θ_2 of reflected light L_R . In certain embodiments, it can be desirable for the reflector surface to be tilted with respect to a vertical axis to increase the reflected angle θ_2 , with respect to horizontal. Furthermore, in certain embodiments, the reflector 1480 is associated with one or more prismatic surfaces that further increase the angle of reflected light. Such prisms may vary over different portions of the reflector in order to increase the amount of light received into a tube opening.

10 **[0155]** FIG. 15 illustrates a perspective view of an embodiment of daylighting device 1500 including a light collector 1510 incorporating a reflector 1580. The daylighting device 1500 includes a light-reflecting tube 1520 disposed adjacent to the light collector 1510. As shown, daylight L_S enters the light collector 1510 through a side portion 1514. The light L_S is refracted by one or more optical elements associated with the side portion 1514 and turned towards an opening in the tube 1520. In certain embodiments, the side portion 1514 is not associated with light turning characteristics, and light L_S entering the light collector 1510 propagates within the light collector at an angle substantially equal to the angle of the light L_S prior to entering the light collector 1510. The presence of the reflector 1580 may increase the effective area of collection of one or more refractive lenses associated with the light collector and configured to turn light towards the tube 1520.

20 **[0156]** The reflector 1580 is disposed along an inside or outside surface of the light collector 1510, such as along a surface that is positioned substantially opposite to a direction at which light L_S may enter the light collector 1510 at one or more points during the day. For example, the reflector 1580 may generally face in a southern direction in an embodiment located at a point in the northern hemisphere. As shown, daylight L_S may enter the light collector 1510 and strike a point on the reflector 1580. The reflector may reflect at least a portion of the daylight in the visible spectrum towards the tube opening 1528. If not for the reflector, a substantial portions of the light L_R may instead propagate out of the tube or be absorbed by materials associated with the light collector 1510. Therefore, inclusion of a reflector 1580 in a day lighting system 1500 may increase the amount of light transmitted through the light collector 1510 into the tube 1520.

25 **[0157]** In certain embodiments, the reflector 1580 has one portion or more than one portion that is sloped at an angle with respect to vertical (not shown). The location of sloped portion can comprise a fraction of the overall height of the reflector 1580, preferably in a region near the top cover portion of the collector 1510. In some embodiments, the sloped portion angles inwardly from vertical. For example, an upper end of the sloped portion can be closer to a centroid of the top cover portion than a lower end of the sloped portion. In some embodiments, the angle of the slope of the sloped portion can be between 1° and 10° from vertical. In some embodiments, the upper end of the sloped portion is adjacent to the top cover portion of the collector 1510. In certain embodiments, the lower end of the sloped portion is at a position that is spaced between one-fifth and on-half of the height of the collector from the top cover portion. For example, the sloped portion can extend a portion of the reflector from the top of the reflector to up to 50% of the height of the collector. In some embodiments, the sloped portion is not greater than $1/3$ of the height of the collector. In some embodiments, the angle of the sloped portion varies along the height of the sloped portion. For example, the angle of the slope at the top of the collector may be greater than the angle of the slope at the bottom of the sloped portion. In some embodiments, the sloped portion may have two or more portions with each portion having a different angle. In a non-limiting example embodiment, the collector height is 50.8 centimeters, the sloping portion of the reflector extends 15.2 centimeters from the top and is sloped inward at 5 degrees from vertical.

30 **[0158]** FIG. 16 illustrates a perspective view of an embodiment of daylighting system 1600 including a light collector 1610 incorporating a reflector 1680. The reflector 1680 can include characteristics allowing for pass-through transmission of certain amounts of light of certain wavelengths. For example, in certain embodiments, the reflector 1680 is at least partially transparent with respect to light in the infrared spectrum. Sunlight includes infrared light and visible light. In general, infrared light transfers thermal energy but provides little or no advantage when the goal is illumination. A daylighting device that directs infrared light into a building can substantially increase temperatures within the building without providing any measurable illumination benefit. In some embodiments, a light collector includes a reflector that allows at least a portion of infrared light that is incident on its surface to pass through the reflector and out of the light collector 1610, rather than reflecting such light in the direction of the tube 1620. In certain embodiments, a light collector 1610 is configured to capture and remove at least a portion of infrared light incident on the collector and/or other spectral wavelengths that do not contribute to visible illumination. In such embodiments, the light collector 1610 can simultaneously turn a substantial portion of visible light, such as, for example, greater than or equal to 95%, greater than or equal to 98%, or greater than or equal to 99% of visible light, towards a daylighting aperture formed in the base of the collector 1610.

35 **[0159]** The dashed line in FIG. 16 shows a possible path of sunlight that is captured by the light collector 1610. When incident on an outside surface of the collector 1610, the sunlight includes visible and infrared light. At least a portion of the light incident on the surface of the at least partially transparent light collector 1610 passes into the interior of the light

collector 1610. The light propagates within the light collector 1610 until it strikes a reflector 1680 positioned to receive at least a portion of the light entering the light collector 1610. In certain embodiments, the reflector 1680 is disposed along an inner or outer surface of a substantially vertical sidewall the light collector 1610. In some embodiments, the light transmits through a second transparent sidewall of the light collector before propagating to a surface of the reflector 1680. The reflector 1680 is configured to turn at least a portion of the light in a direction generally towards an opening of a tube 1620 positioned to receive light that exits the daylight collector 1610 through a daylighting aperture in the base of the collector. In some embodiments, the reflector 1680 is at least partially transparent to infrared light L_{IR} . In such embodiments, a portion of the infrared light L_{IR} transmits through the reflector 1680 and exits the light collector 1610, propagating away from the opening of the tube 1620.

[0160] In certain embodiments, the reflector 1680 is configured to transmit wavelengths other than infrared. For example, the reflector 1680 can partially reflect and partially transmit visible light. As another example, the reflector 1680 can reflect most or substantially all visible light while transmitting and/or absorbing at least a portion of ultraviolet light.

[0161] FIG. 17A illustrates an embodiment of a light collector 1710 having a transparent assembly and a reflective assembly. The light collector 1710 includes a transparent assembly 1711 that is at least partially transparent to daylight incident on its surface. For example, the transparent assembly 1711 can include a sheet of substantially clear acrylic in a semi-circular, curved, planar, and/or segmented configuration. The reflective assembly 1780 can include material for reflecting at least a portion of light incident on one or more of its surfaces. For example, the reflective assembly 1780 can be a semi-circular, curved, planar, and/or segmented reflector. In certain embodiments, the reflective assembly 1780 includes aluminum, reflective film, a metallic reflector, other reflective materials, other optical elements, or a combination of optical elements.

[0162] The transparent portion 1711 and the reflector assembly 1780 can be connected at a seam 1730 to form a combined structure, such as an enclosed cylinder or other shape. The structures can be combined in any suitable manner. For example, the structures can be adhered together through the use of an adhesive substance, or by welding or other technique. In certain embodiments, the structures 1711, 1780 are connected using one or more physical connection structures, such as clips, slots, staples, and the like. For example, as shown in FIG. 17B, which provides a top view of a portion of the light collector 1710, one or more end portions of the respective structures can include male/female slot connecting members for connecting two or more structures. Such a configuration may allow for connection of structures without the need of additional separate connecting devices or materials.

[0163] FIG. 18 illustrates an embodiment of a light collector 1810 having a transparent portion and a reflector assembly. Depending on material characteristics of the reflector assembly 1880, portions of the reflector assembly, or any other component of the light collector 1810, may absorb thermal energy from light (e.g., infrared light) coming in contact therewith. For example, in certain embodiments, the reflector assembly can include aluminum. Heat absorbed by such a structure may contribute to undesirable heating within a light collector, daylighting system and/or interior of a building.

[0164] In certain embodiments, an outside surface 1881 of at least a portion of the light collector 1810 is coated or covered with a layer of material having a relatively high thermal emissivity factor, serving to aid in the transfer of thermal energy away from the light collector 1810. The emissivity factor is related to the ratio of absorbed thermal energy to reflected and/or transmitted thermal energy. In certain embodiments, the outside surface 1881 is in thermal communication with a material having an emissivity factor of greater than about 0.9. Furthermore, high-emissivity material(s) used in connection with a light collector such as that depicted in FIG. 18 may have varying emissivity characteristics for different wavelengths of light. For example, a material can be configured to transmit a relatively high percentage of energy in the infrared spectrum. Material in thermal communication with outer surface 1881 can be in the form of paint or other coating, or can be a sheet or film disposed in the surface 1881. Other components of the daylighting system, such as a daylight-reflective tube, can be coated or lined with high-emissivity materials in order to draw heat away from the interior of the daylighting system, thereby reducing unwanted heating. Examples of types of high-emissivity materials that can be used in connection with a daylighting apparatus include various types of glass (e.g., frosted glass), plastic, sheet metal, paint, powders (e.g., graphite powder), lacquer, or tape (e.g., electrical tape) having high-emissivity characteristics, and can be black or white in color. High-emissivity material can be used in connection with various embodiments of light collecting assemblies as disclosed herein, including light collectors of having any suitable shape or including any suitable material or combination of materials.

[0165] FIG. 19 illustrates an embodiment of a light collector 1910 in a daylighting system 1900. The light collector includes three vertically-arranged optical zones, or segments 1914a, 1914b and 1914c. The segments 1914a, 1914b and 1914c can be of uniform height, or the heights of different segments may vary. In certain embodiments, each segment is approximately 25.4 - 38.1 centimeters tall. For example, the segments 1914a, 1914b and 1914c can be approximately 30.5 centimeters in height. In certain embodiments, a bottom segment, such as segment 1914c, has a greater height than other segments to accommodate attachment of the light collector 1910 to a flashing. For example, the bottom segment 1914c may have a height of about 35.6 centimeters. Furthermore, the light collector can include a lip, or fringe f that extends beyond the opening of the tube 1920.

[0166] Although three segments are shown, a light collector can include any suitable number of segments or portions.

In certain embodiments, different segments can be associated with different optical refraction, transmission and/or reflection characteristics. For example, in some embodiments, at least a portion of the top segment 1914a is associated with a prismatic element 1915, or other optical element or elements. As shown in FIG. 19, the prismatic element 1915 may extend around more than half the circumference of a generally cylindrically-shaped light collector 1900. In certain
5 embodiments, the prismatic element 1915 extends around approximately 270° of the cylindrically shaped collector 1910, and may generally face a direction from which daylight enters the collector 1910, as shown. Providing prismatic element that extends beyond 180° of the perimeter of the light collector may allow for capture of a wider spectrum of light. In certain embodiments, the prismatic element 1915 circumscribes the entire perimeter of the light collector 1910, at least with respect to the top segment 1914a.

[0167] In the depicted embodiment, the middle segment 1914b is also associated with light turning structure 1915, such as prismatic element. A prismatic element 1915 can extend along approximately 50%, or 180°, of the perimeter of the light collector 1910, as shown, and can generally face a direction from which daylight enters the collector 1910. The prismatic element 1915 can be a unitary structure that can extend from segment 1914a to 1914b, or can be separate sheets or films. The prismatic element 1915 can include prisms having similar or different light-turning characteristics.
15 In certain embodiments, the segment of the prismatic element 1915 positioned in segment 1914a is configured to turn daylight to a greater degree than the segment of the prismatic element 1915 positioned in segment 1914b.

[0168] Collector segment 1914c can be associated with light-turning prismatic structure, or may not, depending on collector 1910 characteristics. For example, as shown, the segment 1914c may allow for daylight to pass into the collector 1910 without substantially altering an angle of the daylight with respect to a horizontal plane. Therefore, the segment
20 1915c may present a substantially clear acrylic material without additional optical elements to daylight entering therein.

[0169] In addition to, or in place of, a light turning structure 1915, one or more portions or segments of the light collector 1910 can be associated with a reflector assembly 1980. In the embodiment shown in FIG. 19, a reflector 1980 is disposed in proximity to an inside surface of the sidewall of the light collector 1910 along portions of light collector segments 1914a, 1914b, and 1914c. It can be desirable to include one or more reflectors in at least a lower portion of the light
25 collector 1910 because light striking a reflector in a lower portion of the light collector 1910 can be more likely to reflect into the tube 1920 rather than exiting out the opposite side of the collector. For example, in an embodiment including a reflector in the top segment 1914a, light striking the reflector at a point in segment 1914a may have a further distance to travel in order to reach the tube 1920. Therefore, the angle of trajectory may carry the light out of the collector before it reaches the tube 1920. In certain embodiments, a segment of the collector 1920 is not associated with the reflector assembly 1980. In some embodiments, a light collector 1910 having a reflector 1980 can have a height that is greater than or equal to about twice the height of a light collector that does not have a reflector. In some embodiments, a light collector 1910 having a reflector 1980 limits the collection of light at sun azimuthal angles greater than 60 to 90 degrees when the reflector 1980 is facing south.

[0170] Reflective characteristics of the reflector 1980 may vary in different portions or segments of the reflector. Furthermore, while FIG. 19 shows the reflector as a singular piece, the reflector can include distinct pieces or structures. The reflector 1980, or portions of the thereof may span any suitable portion of the circumference, or perimeter, of the light collector 1910. In certain embodiments, the reflector 1980 spans approximately 180° of the light collector's perimeter, as shown. The reflector can be positioned generally at a back portion of the light collector with respect to a direction from which daylight enters the light collector 1910. In certain embodiments, and under certain daylight conditions, the
35 light collector 1910 and reflector 1980 can be configured such that approximately 85% or more of the light entering the collector will be directed to the reflector 1980, and can allow for the removal of infrared light from daylight before the daylight enters the tube 1920.

[0171] The reflector 1980 can be constructed from a material system that has high luminous reflectance and high transmittance of infrared light. The finish of the reflector 1980 can be specular or have any desired level of specularity. Wavelength-selective light reflectance can be achieved using any suitable materials. Examples of wavelength-selective material systems include dielectric coatings and/or multi-layer films that use small differences in refractive index between many layers of the film to achieve desired optical properties. Multi-layer films can include coextruded stacks of two or more polymers having different refractive indices. FIG. 24 shows the reflectivity profile of a multi-layer film, 3M Daylighting Film DF2000MA, which is available from the 3M Company of Maplewood, Minnesota, USA. This polymeric film is an
45 example of a multi-layer film that can be part of the material system of the reflector 1980 or as the reflector 1980. The reflectivity profile of an enhanced silver coating is also shown. The multi layer film provides very high reflectivity in the visible region, having a luminous reflectance greater than 99% when measured with respect to CIE Illuminant D₆₅. The film has substantially lower reflectivity of infrared light; the reflectivity of infrared light is less than or equal to about 20%. The reflectivity of ultraviolet light is also substantially lower than the reflectivity of visible light. In comparison, the enhanced silver coating has lower luminous reflectance and infrared light reflectivity greater than 90%.

[0172] After infrared light is transmitted through a wavelength-selective reflector 1980, the infrared light can transmit through an infrared transmissive material, such as, for example, acrylic or PET. In some embodiments, the sidewall of the collector 1910 is made from an infrared transmissive material. In some embodiments, the infrared light is absorbed

after transmitting through a wavelength-selective reflector 1980. In such embodiments, the infrared light can be absorbed by an infrared absorbing paint or adhesive positioned to receive the infrared light after it transmits through the reflector 1980. In some embodiments, the infrared paint or adhesive is adhered to a metal substrate. The metal substrate can form a portion of the sidewall of the collector that is not transparent (e.g., a portion of the sidewall configured to face away from direct sunlight). The metal substrate can be heated by the paint or adhesive when it absorbs infrared light, and the infrared light can then be reemitted in a direction generally away from the daylighting aperture 1918 and the tube 1920.

[0173] In some embodiments, an exterior surface of the portion of the sidewall of the collector 1910 that absorbs infrared light has high emissivity. High emissivity can be obtained by applying a high emissivity material, such as paint, to the surface, or by performing another type of surface treatment, such as anodization. At least some anodized metals exhibit high emissivity, and such metals can form at least a portion of the exterior surface of the light collector 1910. A high emissivity surface can also be provided on the outside surface of the tube 1920, which can permit the tube 1920 to readily reemit infrared radiation absorbed by the tube 1920 out of the daylighting device 1900.

[0174] In certain embodiments, the daylighting device 1900 is configured to reject heat during summer months, when the solar altitude is higher, and to direct heat into the building being illuminated by the daylighting device during winter months, when the solar altitude is lower.

[0175] A daylighting device incorporating a light collector in accordance with the embodiments described above can be configured to maintain an illumination level within a range of about +/- 20% of a given value throughout a period of interest, such as the hours from around 9:00am to 3:00pm. Furthermore, such a device may provide around 20,000 lumens of light, or more, at a given time, depending on, among other things, external daylight conditions.

[0176] FIG. 20 illustrates an embodiment of a light collector 2010. The figure shows two vertically-arranged zones, or segments, 'A' and 'B.' The segments A and B can be of uniform height, or the heights of different segments may vary. In certain embodiments, the segment A represents a portion of a vertical side portion of the light collector 2010 that is associated with prismatic structure 2015a, at least over some portion of the circumference or perimeter of the side portion. Furthermore, the segment B may represent a portion of the vertical side portion of the light collector 2010 that is not associated with prismatic structure. The light collector 2010 can include a back half-cylinder portion, which can include reflective properties. For example, at least a portion of the back portion 2080 can include or be associated with aluminum, or other reflective material. In certain embodiments, the vertical walls of the light collector 2010 can be configured to capture daylight having a solar altitude of approximately 20°-50°.

[0177] The light collector 2010 can include a substantially clear dome-shaped cover portion 2012. The cover portion 2012 can be configured to capture daylight having a solar altitude of approximately 30°-90°. The combination of vertical sidewall and dome-shaped cover portions may provide improved performance during both clear and cloudy weather conditions.

[0178] In general, with respect to a light collector embodiments in accordance with FIG. 20, greater performance at lower solar elevations (e.g., 20°-40°) can be achievable with higher aspect ratios (i.e., height of vertical collector portion C vs. width of tube opening w_t). With respect to daylight at solar altitudes greater than 40°, the horizontal daylight-collection surface provided by the cover 2012 may provide the majority of daylight capture. In certain embodiments, an aspect ratio of approximately 1.9 will produce approximately 40% or more improvement in captured light at 20° and/or 30° when compared to an aspect ratio of approximately 1.3 or less. However, performance at 40°-90° may remain approximately steady for both configurations.

[0179] Design considerations in manufacturing daylight collectors in accordance with one or more embodiments disclosed herein may take into consideration various cost-related and/or other factors. For example, different materials that can be selected for incorporation in a daylight collector can be available at different prices. Furthermore, different materials may have different physical properties contributing to the performance and/or ease of manufacturing of various components of the collector. Therefore, certain information about the physical dimensions of a light collector can be useful in making design or other decisions. Table E provides example physical specifications for a number of possible embodiments of daylight collectors. The dimensions provided in Table E correspond to the areas and dimensions called out in FIG. 20. Table E provides size and area information that can be helpful in assessing cost/performance issues associated with the respective embodiments, as well as other embodiments.

Table E

Collector Type	High Aspect Ratio	Scaled-Up High Aspect Ratio	Low Aspect Ratio	Scaled-Up Low Aspect Ratio
Collector Diameter (W_c)	23"	27.3"	23"	27.3"
Tube Diameter (W_t)	21"	25.3"	21"	25.3"

(continued)

Collector Type	High Aspect Ratio	Scaled-Up High Aspect Ratio	Low Aspect Ratio	Scaled-Up Low Aspect Ratio
A	23.6"	28.2"	10.4"	12.5"
B	18.0"	21.1"	18.0"	21.1"
C	41.6"	49.3"	28.4"	33.6"
Cover (2012) Surface Area	2.88 ft ²	4.09 ft ²	2.88 ft ²	4.09 ft ²
Front Prismatic Portion (2015a) Area	5.9 ft ²	8.40 ft ²	2.6 ft ²	3.7 ft ²
Front Prismatic Portion (2015a) Size	23/6" x 36.1"	28.2" x 42.8"	10.4" x 36.1"	12.5" x 42.8"
Back Portion (2080) Area	10.4 ft ²	14.7 ft ²	7.2 ft ²	10.0 ft ²
Back Portion (2080) Size	41.6" x 36.1"	49.3" x 42.8"	28.4" x 36.1"	33.6" x 42.8"

[0180] The values provided in Table E are approximations of various possible daylight collector dimensions, and are not limiting on the scope of the disclosure in any way. Furthermore, although certain values are provided in the table, the respective collector dimensions need not conform in any way to such values, and can be configured to be any suitable dimensions. As shown in the table, construction of a daylight collector may demand more than 8 ft² of prismatic material, as well as more than 14 ft² of reflective back portion material. Therefore, costs associated at least with such materials/areas may represent a significant factor in daylight collector design.

[0181] In certain embodiments, a light collector in accordance with one or more embodiments described herein can be configured such that fabrication and/or installation of the collector are simplified. For example, the side portion of a light collector 2014 can be formed from a substantially flat or curved sheet that can be formed into a generally cylindrical shape, as shown by the top view of FIG. 21A. Such a configuration, as installed, may have a singular vertical seam that can be, for example, secured by an attaching member 2019, or in any other suitable way.

[0182] FIG. 21B shows top view of an embodiment of a portion of a light collector, wherein the circumference of the light collector is made up of multiple segments 2114a, 2114b and 2114c, that can be attached in any suitable manner, such as by using attaching members 2119a, 2119b, and/or 2119c. With respect to the embodiments depicted in both FIG. 21A and 21, a flat, slightly curved, or otherwise shaped top cover can be placed on the collector top.

[0183] FIG. 22 illustrates a packaging configuration for one or more curved light collector portions. For example, with respect to the embodiments of FIGS. 20 and 21, which can include one or more curved panels that can be formed into a cylinder or other shape, such panels can be disposed in a stacked configuration in a package 2290 for shipping, transporting, storing, or for other purposes. FIG. 23 illustrates a packaging configuration in which one or more curved panels 2314a, 2314b, 2314c are concentrically arranged in a package 2390. The packages shown can allow space for prismatic and/or reflective components, or any other components, associated with a daylighting device. Such packaging configurations may reduce cost and/or effort associated with the manufacture, transportation, and/or installation of one or more components of a daylighting device.

[0184] At least some of the embodiments disclosed herein may provide one or more advantages over existing lighting systems. For example, certain embodiments effectively allow increased daylight capture through the use of a light collector incorporating one or more prismatic elements and/or reflective elements. As another example, some embodiments provide techniques for directing light to a building interior using a light collector having a height greater than the width of an opening in the building, or of a base aperture of the collector, through which light is transmitted. The height of the collector may provide an increased target light capture area. Certain embodiments may provide additional benefits, including reducing the incident angle at the diffuser of light propagating through the daylighting device, which can result in the diffuser operating with higher optical efficiency.

[0185] Discussion of the various embodiments disclosed herein has generally followed the embodiments illustrated in the figures. However, it is contemplated that the particular features, structures, or characteristics of any embodiments discussed herein can be combined in any suitable manner in one or more separate embodiments not expressly illustrated or described. It is understood that the fixtures disclosed herein can be used in at least some systems and/or other lighting installations besides daylighting systems.

[0186] It should be appreciated that in the above description of embodiments, various features are sometimes grouped

together in a single embodiment, figure, or description thereof for the purpose of streamlining the disclosure and aiding in the understanding of one or more of the various aspects. This method of disclosure, however, is not to be interpreted as reflecting an intention that any claim require more features than are expressly recited in that claim. Moreover, any components, features, or steps illustrated and/or described in a particular embodiment herein can be applied to or used with any other embodiment(s). Thus, it is intended that the scope of the inventions herein disclosed should not be limited by the particular claimed embodiment described in fig. 10f but should be determined only by a fair reading of the claims that follow.

Claims

1. A skylight (1110) assembly comprising:

a skylight cover (1102);
 a prismatic element (1015b) configured to refract at least a portion of light that passes through the skylight cover, wherein the prismatic element comprises a planar surface and a prismatic surface comprising at least one prism having a riser surface and a draft surface, wherein the prismatic surface is opposite the planar surface, and wherein the planar surface is positioned between the prismatic surface and the skylight cover, a riser angle of the riser surface being between about 35 degrees and about 43 degrees or between about 45 degrees and about 55 degrees with respect to a surface normal to the non-prismatic surface; and
 an element positioning assembly configured to:

position the skylight assembly over an opening in a roof of a building;
 dispose the prismatic element relative to the plane of the roof such that an angle formed at an intersection of a second plane containing the prismatic element and the plane of the roof is greater than 0 degrees but less than or equal to about 40 degrees, and
 orient the prismatic element so that the riser surface faces the sun and directs daylight into the opening in the roof, wherein the skylight cover is angled relative to the plane of the roof, the skylight cover having a pole side and an equatorial side, the equatorial side being positioned closer to the equator and the pole side being opposite the equatorial side, wherein the pole side of the skylight cover is offset from the roof, and the equatorial side is positioned closer to the roof than the pole side.

2. The skylight assembly of claim 1, wherein the riser angle is between about 35 degrees and about 43 degrees.
3. The skylight assembly of claim 1, wherein the riser angle is between about 45 degrees and about 55 degrees.
4. The skylight assembly of claim 1, wherein the prismatic element comprises a prismatic film having at least one surface positioned parallel to the skylight cover.
5. The skylight assembly of claim 1, wherein the prismatic element comprises a plurality of prismatic grooves.
6. The skylight assembly of claim 5, wherein at least a portion of the prismatic grooves are formed in at least one of a radial pattern, a linear pattern, or a curve-linear pattern.
7. The skylight assembly of claim 1, wherein the prismatic element is positioned less than or equal to 15.24 cm from the plane of the roof.
8. The skylight assembly of claim 1, wherein the skylight cover is clear, and wherein the skylight cover is substantially flat, angled, or at least partially dome-shaped.
9. The skylight assembly of claim 1, wherein the prismatic element is integrally formed into the skylight cover.
10. A skylight assembly of claim 1 wherein a riser angle of the riser surface is from 35 degrees to 43 degrees relative to a surface normal to the non-prismatic surface.
11. The skylight assembly of claim 10, wherein the positioning assembly includes at least one of: an adhesive that bonds the prismatic element to the skylight cover; a frame that holds the prismatic element within 15.24 cm of the skylight cover; a spacer configured to be positioned between the prismatic element and the skylight cover; a tab or slot for

attachment to the prismatic element; or an adhesive that bonds the prismatic element to a portion of the skylight assembly near the skylight cover.

5 12. The skylight assembly of claim 10, wherein angling the prismatic element forms a raised side of the prismatic element along at least one edge of the prismatic element, wherein the raised side is a side other than the side of the prismatic element closest to the equator.

13. A method of installation of a skylight assembly, the method comprising:

10 providing a skylight assembly, the skylight assembly comprising a skylight cover; and
a prismatic element configured to refract at least a portion of light that passes through the skylight cover, wherein the prismatic element comprises a planar surface and a prismatic surface, wherein the prismatic surface is opposite the planar surface, and wherein the planar surface is positioned between the prismatic surface and
15 the skylight cover, wherein the prismatic surface comprises at least one prism having a riser surface and a draft surface, and the method of installation of the skylight assembly comprises
positioning the skylight assembly over an opening in a roof of a building;
disposing the prismatic element relative to the plane of the roof such that an angle formed at an intersection of a second plane containing the prismatic element and the plane of the roof is greater than 0 degrees but less
20 than or equal to about 40 degrees; and
orienting the prismatic element so that the riser surface faces the sun and directs daylight into the opening in the roof when the skylight assembly is installed as part of a skylight assembly installation, wherein the skylight cover is angled relative to the plane of the roof, the skylight cover having a pole side and an equatorial side, the equatorial side being positioned closer to the equator and the pole side being opposite the equatorial side,
25 wherein the pole side of the skylight cover is offset from the roof, and the equatorial side is positioned closer to the roof than the pole side, wherein a riser angle of the riser surface is between about 35 and about 43 degrees or between about 45 degrees and about 55 degrees with respect to a surface normal to the planar surface.

14. A method according to claim 13, comprising

30 positioning the prismatic element so that no portion of the prismatic element is above 15.24 cm of the plane of the roof.

Patentansprüche

35 1. Oberlichtanordnung (1110), die Folgendes umfasst:

eine Oberlichtabdeckung (1102);
ein prismatisches Element (1015b), ausgelegt zum Brechen zumindest eines Teils von Licht, das die Oberlichtabdeckung passiert, wobei das prismatische Element eine planare Oberfläche und eine prismatische Oberfläche, umfassend zumindest ein Prisma mit einer Steigfläche und einer Rücksetzfläche, umfasst, wobei die
40 prismatische Oberfläche der planaren Oberfläche gegenüberliegt und wobei die planare Oberfläche zwischen der prismatischen Oberfläche und der Oberlichtabdeckung positioniert ist, wobei ein Steigwinkel der Steigfläche zwischen etwa 35 Grad und etwa 43 Grad oder zwischen etwa 45 Grad und etwa 55 Grad bezüglich einer Oberfläche ist, die normal zur nicht-prismatischen Oberfläche ist; und
45 eine Elementpositionierungsanordnung, die ausgelegt ist zum:

Positionieren der Oberlichtanordnung über einer Öffnung in einem Dach eines Gebäudes;
Anordnen des prismatischen Elements relativ zur Ebene des Daches, sodass ein Winkel, der an einer Schnittlinie einer zweiten Ebene, die das prismatische Element enthält, und der Ebene des Daches gebildet wird, größer als 0 Grad, aber kleiner als oder gleich etwa 40 Grad ist, und
50 Ausrichten des prismatischen Elements, sodass die Steigfläche zur Sonne zeigt und Tageslicht in die Öffnung im Dach leitet, wobei die Oberlichtabdeckung relativ zur Ebene des Daches angewinkelt ist, die Oberlichtabdeckung eine Polseite und eine Äquatorseite aufweist, die Äquatorseite näher am Äquator positioniert ist und die Polseite der Äquatorseite gegenüberliegt, wobei die Polseite der Oberlichtabdeckung vom Dach versetzt ist und die Äquatorseite näher am Dach positioniert ist als die Polseite.

55 2. Oberlichtanordnung nach Anspruch 1, wobei der Steigwinkel zwischen etwa 35 Grad und etwa 43 Grad ist.

EP 3 516 129 B1

3. Oberlichtanordnung nach Anspruch 1, wobei der Steigwinkel zwischen etwa 45 Grad und etwa 55 Grad ist.
4. Oberlichtanordnung nach Anspruch 1, wobei das prismatische Element eine prismatische Folie umfasst, die zumindest eine Oberfläche aufweist, die parallel zur Oberlichtabdeckung positioniert ist.
5. Oberlichtanordnung nach Anspruch 1, wobei das prismatische Element mehrere prismatische Nuten umfasst.
6. Oberlichtanordnung nach Anspruch 5, wobei zumindest ein Teil der prismatischen Nuten in zumindest einem aus einem radialen Muster, einem linearen Muster oder einem kurven-linearen Muster gebildet ist.
7. Oberlichtanordnung nach Anspruch 1, wobei das prismatische Element weniger als oder gleich 15,24 cm von der Ebene des Daches entfernt positioniert ist.
8. Oberlichtanordnung nach Anspruch 1, wobei die Oberlichtabdeckung durchsichtig ist, und wobei die Oberlichtabdeckung im Wesentlichen flach, angewinkelt oder zumindest teilweise kuppelförmig ist.
9. Oberlichtanordnung nach Anspruch 1, wobei das prismatische Element integral in die Oberlichtabdeckung eingefügt ist.
10. Oberlichtanordnung nach Anspruch 1, wobei ein Steigwinkel der Steigfläche von 35 Grad bis 43 Grad relativ zu einer Oberfläche ist, die normal zur nicht-prismatischen Oberfläche ist.
11. Oberlichtanordnung nach Anspruch 10, wobei die Positionierungsanordnung zumindest eines aus Folgendem umfasst: einen Klebstoff, der das prismatische Element an die Oberlichtabdeckung klebt; einen Rahmen, der das prismatische Element innerhalb von 15,24 cm der Oberlichtabdeckung hält; ein Distanzstück, dazu ausgelegt, zwischen dem prismatischen Element und der Oberlichtabdeckung positioniert zu werden; eine Nase oder ein Schlitz zur Befestigung an dem prismatischen Element; oder einen Klebstoff, der das prismatische Element an einen Teil der Oberlichtanordnung nahe der Oberlichtabdeckung klebt.
12. Oberlichtanordnung nach Anspruch 10, wobei Anwinkeln des prismatischen Elements eine erhöhte Seite des prismatischen Elements entlang zumindest einer Kante des prismatischen Elements bildet, wobei die erhöhte Seite eine Seite ist, die von der Seite des prismatischen Elements, die dem Äquator am nächsten ist, verschieden ist.
13. Verfahren zur Installation einer Oberlichtanordnung, wobei das Verfahren Folgendes umfasst:
Bereitstellen einer Oberlichtanordnung, wobei die Oberlichtanordnung Folgendes umfasst:
 - eine Oberlichtabdeckung; und
 - ein prismatisches Element, ausgelegt zum Brechen zumindest eines Teils von Licht, das die Oberlichtabdeckung passiert, wobei das prismatische Element eine planare Oberfläche und eine prismatische Oberfläche umfasst, wobei die prismatische Oberfläche der planaren Oberfläche gegenüberliegt, und wobei die planare Oberfläche zwischen der prismatischen Oberfläche und der Oberlichtabdeckung positioniert ist, wobei die prismatische Oberfläche zumindest ein Prisma mit einer Steigfläche und einer Rücksetzfläche umfasst, und wobei das Verfahren zur Installation der Oberlichtanordnung Folgendes umfasst:
 - Positionieren der Oberlichtanordnung über einer Öffnung in einem Dach eines Gebäudes;
 - Anordnen des prismatischen Elements relativ zur Ebene des Daches, sodass ein Winkel, der an einer Schnittlinie einer zweiten Ebene, die das prismatische Element enthält, und der Ebene des Daches gebildet wird, größer als 0 Grad, aber kleiner als oder gleich etwa 40 Grad ist, und
 - Ausrichten des prismatischen Elements, sodass die Steigfläche zur Sonne zeigt und Tageslicht in die Öffnung im Dach leitet, wenn die Oberlichtanordnung als Teil einer Oberlichtanordnungsinstallation installiert ist, wobei die Oberlichtabdeckung relativ zur Ebene des Daches angewinkelt ist, die Oberlichtabdeckung eine Polseite und eine Äquatorseite aufweist, die Äquatorseite näher am Äquator positioniert ist und die Polseite der Äquatorseite gegenüberliegt, wobei die Polseite der Oberlichtabdeckung vom Dach versetzt ist und die Äquatorseite näher am Dach positioniert ist als die Polseite, wobei ein Steigwinkel der Steigfläche zwischen etwa 35 Grad und etwa 43 Grad oder zwischen etwa 45 Grad und etwa 55 Grad bezüglich einer Oberfläche ist, die normal zur nicht-prismatischen Oberfläche ist.
14. Verfahren nach Anspruch 13, das Folgendes umfasst: Positionieren des prismatischen Elements, sodass kein Teil

des prismatischen Elements mehr als 15,24 cm von der Ebene des Daches entfernt ist.

Revendications

- 5
1. Ensemble de lanterneau (1110) comportant :
- un couvercle (1102) de lanterneau ;
un élément prismatique (1015b) configuré pour réfracter au moins une partie d'une lumière qui traverse le
10 couvercle de lanterneau, l'élément prismatique comportant une surface plane et une surface prismatique com-
portant au moins un prisme présentant une surface de hausse et une surface en dépouille, la surface prismatique
étant opposée à la surface plane, et la surface plane étant positionnée entre la surface prismatique et le couvercle
de lanterneau, un angle de hausse de la surface de hausse étant compris entre environ 35 degrés et environ
15 43 degrés ou entre environ 45 degrés et environ 55 degrés par rapport à une surface normale à la surface non
prismatique ; et
un ensemble de positionnement d'élément configuré pour :
- positionner l'ensemble de lanterneau par-dessus une ouverture dans un toit d'un bâtiment ;
disposer l'élément prismatique par rapport au plan du toit de telle façon qu'un angle formé à une intersection
20 d'un second plan contenant l'élément prismatique et du plan du toit soit supérieur à 0 degrés mais inférieur
ou égal à environ 40 degrés, et
orienter l'élément prismatique de telle façon que la surface de hausse se trouve face au soleil et dirige la
lumière du jour dans l'ouverture dans le toit, le couvercle de lanterneau étant incliné par rapport au plan
du toit, le couvercle de lanterneau présentant un côté polaire et un côté équatorial, le côté équatorial étant
25 positionné plus près de l'équateur et le côté polaire étant opposé au côté équatorial, le côté polaire du
couvercle de lanterneau étant décalé par rapport au toit, et le côté équatorial étant positionné plus près du
toit que le côté polaire.
- 30
2. Ensemble de lanterneau selon la revendication 1, l'angle de hausse étant compris entre environ 35 degrés et environ
43 degrés.
3. Ensemble de lanterneau selon la revendication 1, l'angle de hausse étant compris entre environ 45 degrés et environ
55 degrés.
- 35
4. Ensemble de lanterneau selon la revendication 1, l'élément prismatique comportant un film prismatique doté d'au
moins une surface positionnée parallèlement au couvercle de lanterneau.
- 40
5. Ensemble de lanterneau selon la revendication 1, l'élément prismatique comportant une pluralité de rainures pris-
matiques.
6. Ensemble de lanterneau selon la revendication 5, au moins une partie des rainures prismatiques étant formée
suivant au moins un motif parmi un motif radial, un motif linéaire, ou un motif curvilinéaire.
- 45
7. Ensemble de lanterneau selon la revendication 1, l'élément prismatique étant positionné à au plus 15,24 cm du
plan du toit.
8. Ensemble de lanterneau selon la revendication 1, le couvercle de lanterneau étant transparent, et le couvercle de
lanterneau étant sensiblement plat, incliné, ou au moins partiellement en forme de dôme.
- 50
9. Ensemble de lanterneau selon la revendication 1, l'élément prismatique étant formé de manière intégrée dans le
couvercle de lanterneau.
10. Ensemble de lanterneau selon la revendication 1, un angle de hausse de la surface de hausse étant de 35 degrés
à 43 degrés par rapport à une surface normale à la surface non prismatique.
- 55
11. Ensemble de lanterneau selon la revendication 10, l'ensemble de positionnement comprenant au moins un élément
parmi: un adhésif qui colle l'élément prismatique au couvercle de lanterneau; un cadre qui maintient l'élément
prismatique en-deçà de 15,24 cm du couvercle de lanterneau; une entretoise configurée pour être positionnée entre

EP 3 516 129 B1

l'élément prismatique et le couvercle de lanterneau; un tenon ou une mortaise servant à la fixation à l'élément prismatique; ou un adhésif qui colle l'élément prismatique à une partie de l'ensemble de lanterneau près du couvercle de lanterneau.

5 **12.** Ensemble de lanterneau selon la revendication 10, le fait d'incliner l'élément prismatique formant un côté surélevé de l'élément prismatique le long d'au moins un bord de l'élément prismatique, le côté surélevé étant un côté autre que le côté de l'élément prismatique le plus proche de l'équateur.

10 **13.** Procédé d'installation d'un ensemble de lanterneau, le procédé comportant les étapes consistant à :

mettre en place un ensemble de lanterneau, l'ensemble de lanterneau comportant un couvercle de lanterneau ; et un élément prismatique configuré pour réfracter au moins une partie d'une lumière qui traverse le couvercle de lanterneau, l'élément prismatique comportant une surface plane et une surface prismatique, la surface prismatique étant opposée à la surface plane, et la surface plane étant positionnée entre la surface prismatique et le couvercle de lanterneau, la surface prismatique comportant au moins un prisme présentant une surface de hausse et une surface en dépouille, et le procédé d'installation de l'ensemble de lanterneau comportant les étapes consistant à positionner l'ensemble de lanterneau par-dessus une ouverture dans un toit d'un bâtiment ;
20 disposer l'élément prismatique par rapport au plan du toit de telle façon qu'un angle formé à une intersection d'un second plan contenant l'élément prismatique et du plan du toit soit supérieur à 0 degrés mais inférieur ou égal à environ 40 degrés ; et orienter l'élément prismatique de telle façon que la surface de hausse se trouve face au soleil et dirige la lumière du jour dans l'ouverture dans le toit lorsque l'ensemble de lanterneau est installé dans le cadre d'une installation
25 d'ensemble de lanterneau, le couvercle de lanterneau étant incliné par rapport au plan du toit, le couvercle de lanterneau présentant un côté polaire et un côté équatorial, le côté équatorial étant positionné plus près de l'équateur et le côté polaire étant opposé au côté équatorial, le côté polaire du couvercle de lanterneau étant décalé par rapport au toit, et le côté équatorial étant positionné plus près du toit que le côté polaire, un angle de hausse de la surface de hausse étant compris entre environ 35 et environ 43 degrés ou entre environ 45
30 degrés et environ 55 degrés par rapport à une surface normale à la surface plane.

14. Procédé selon la revendication 13, comportant le positionnement de l'élément prismatique de telle façon qu'aucune partie de l'élément prismatique ne se trouve à plus de 15,24 cm du plan du toit.

35

40

45

50

55

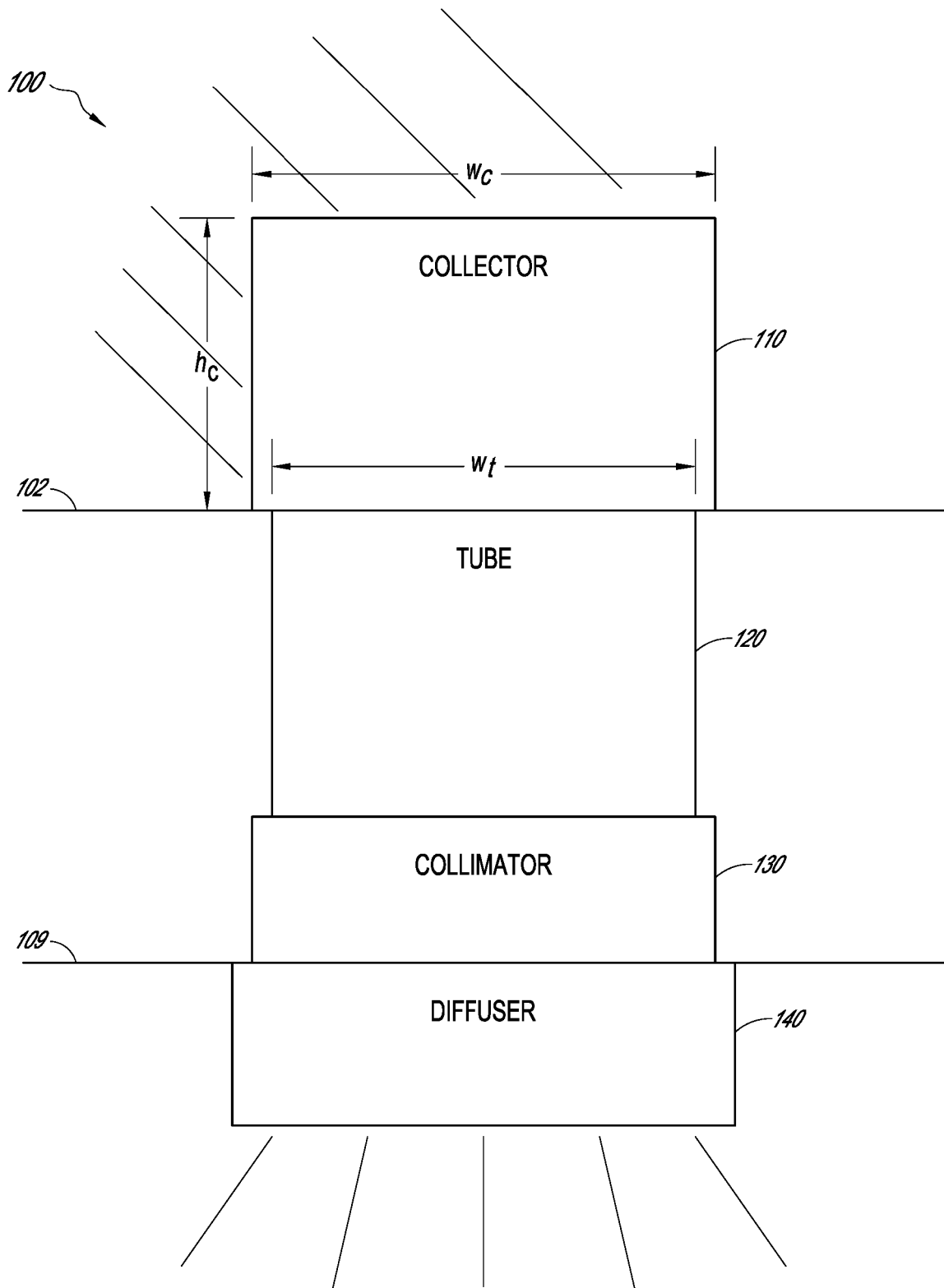

FIG. 1

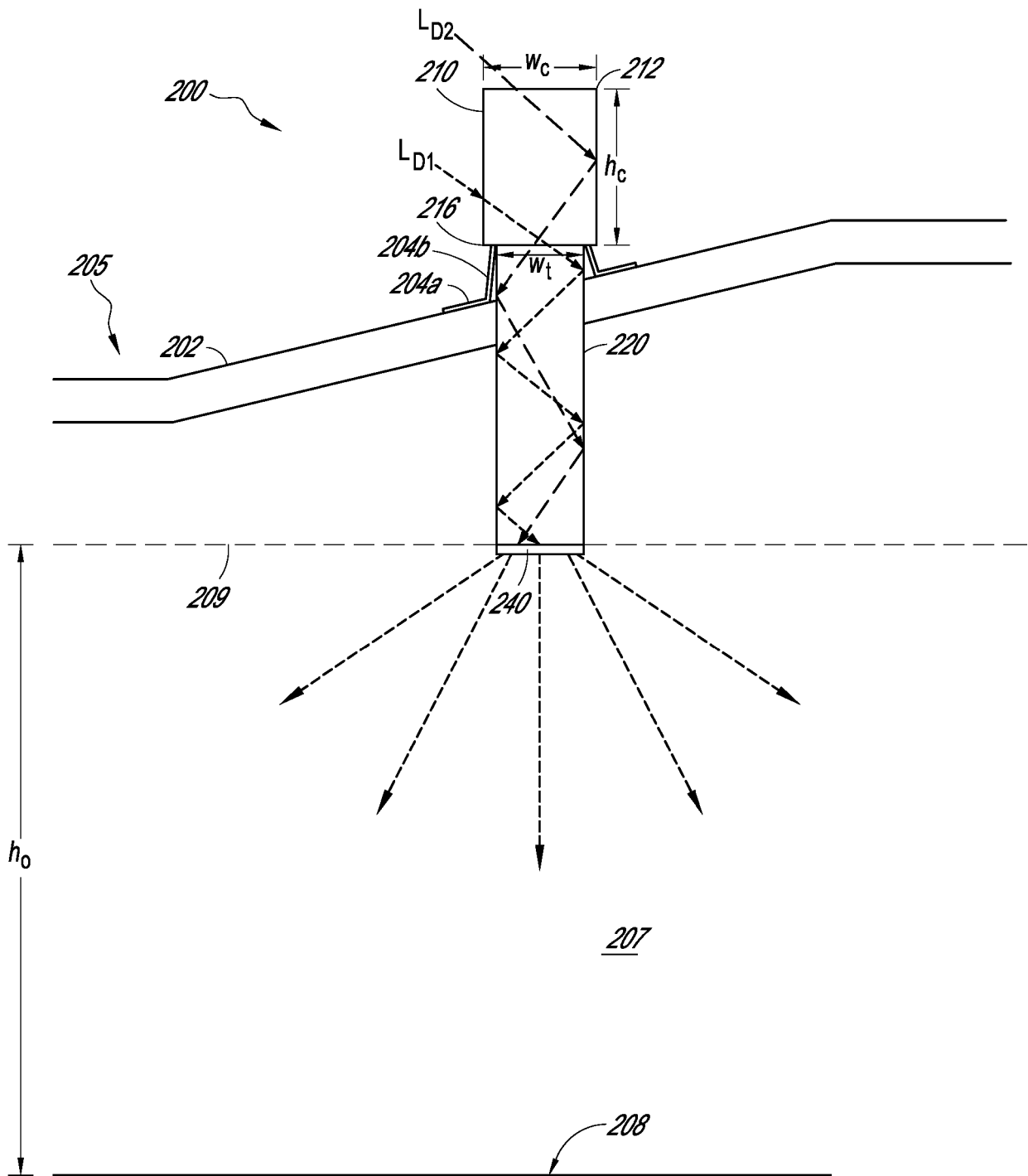

FIG. 2

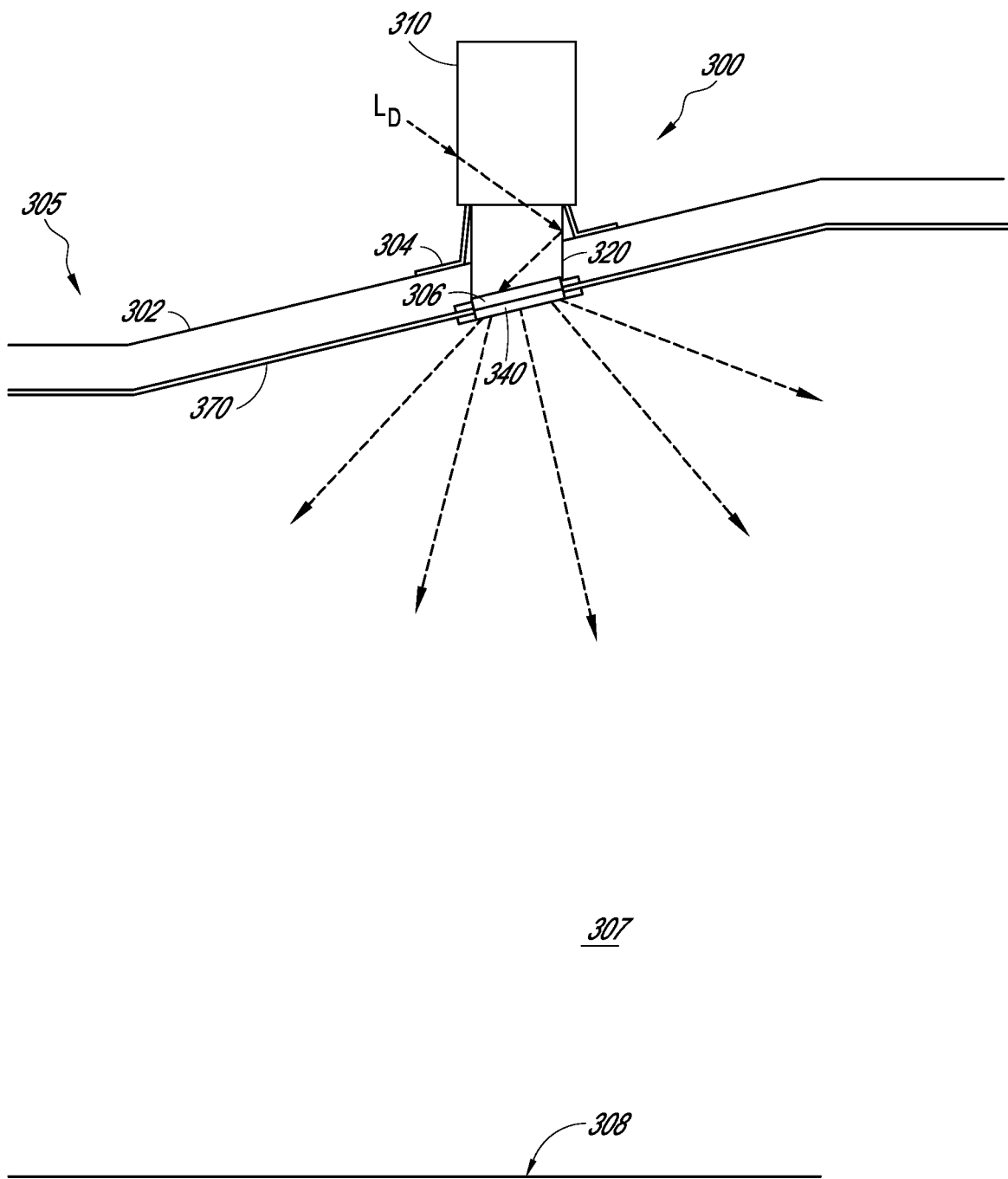

FIG. 3

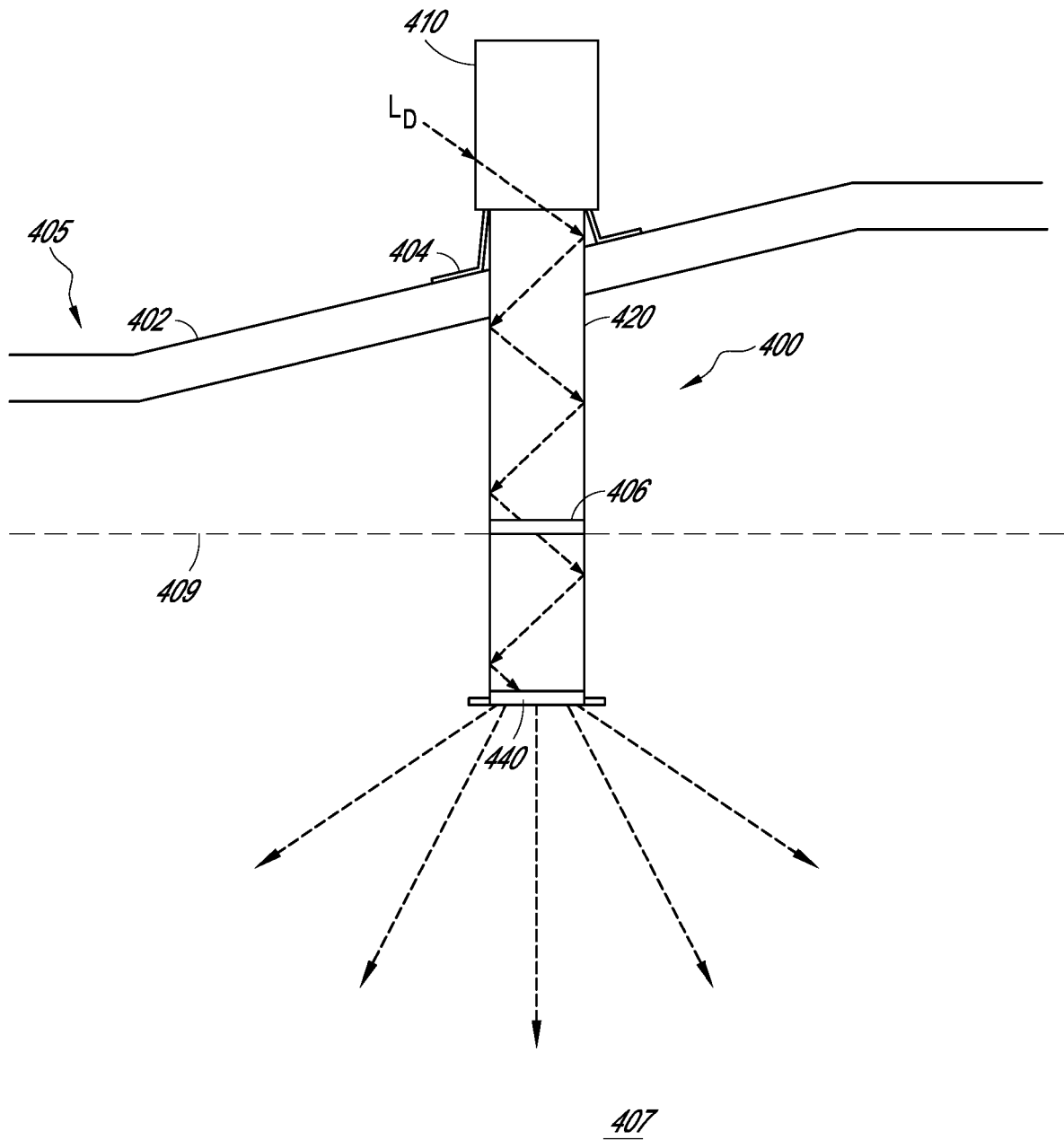

FIG. 4

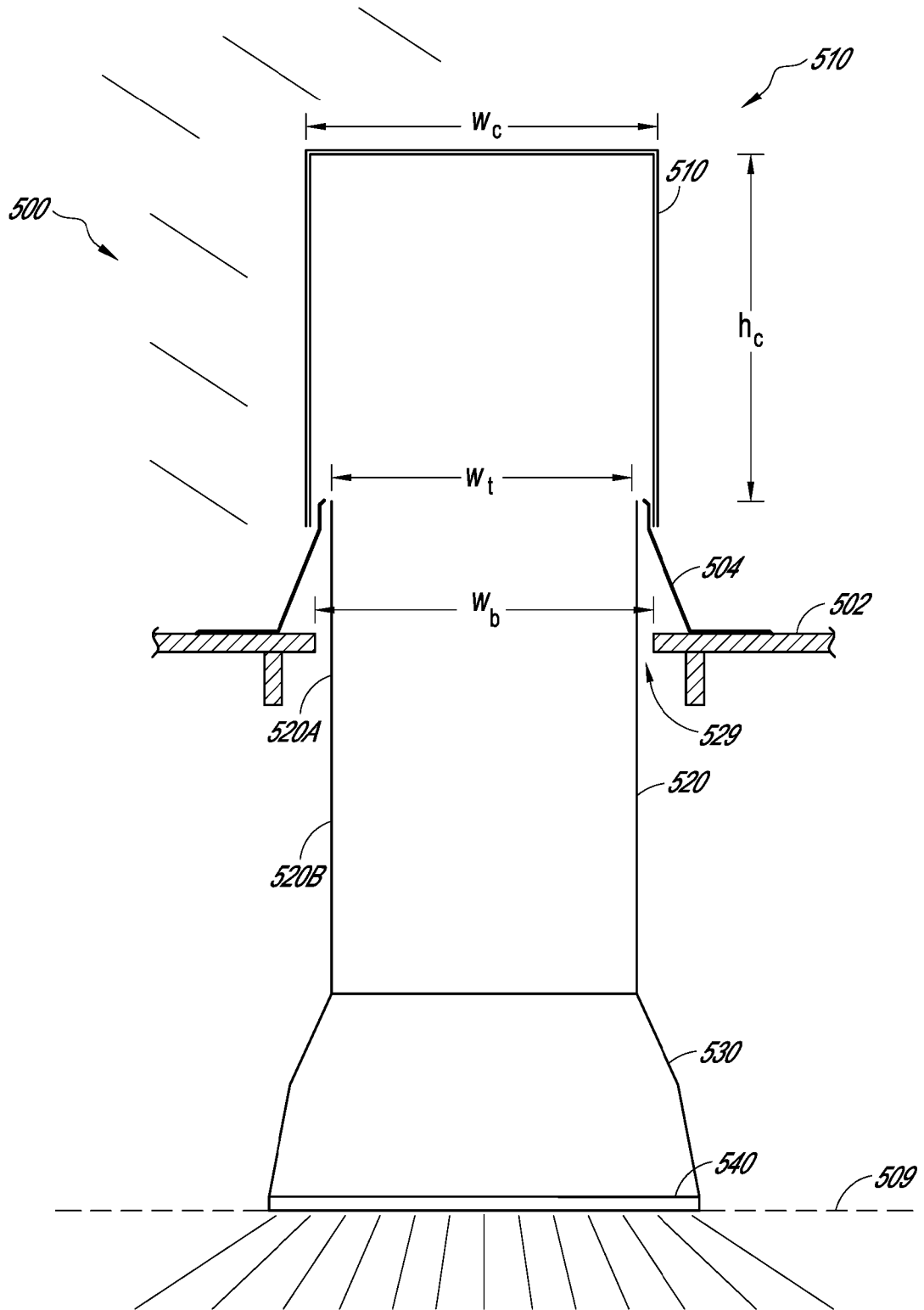

FIG. 5

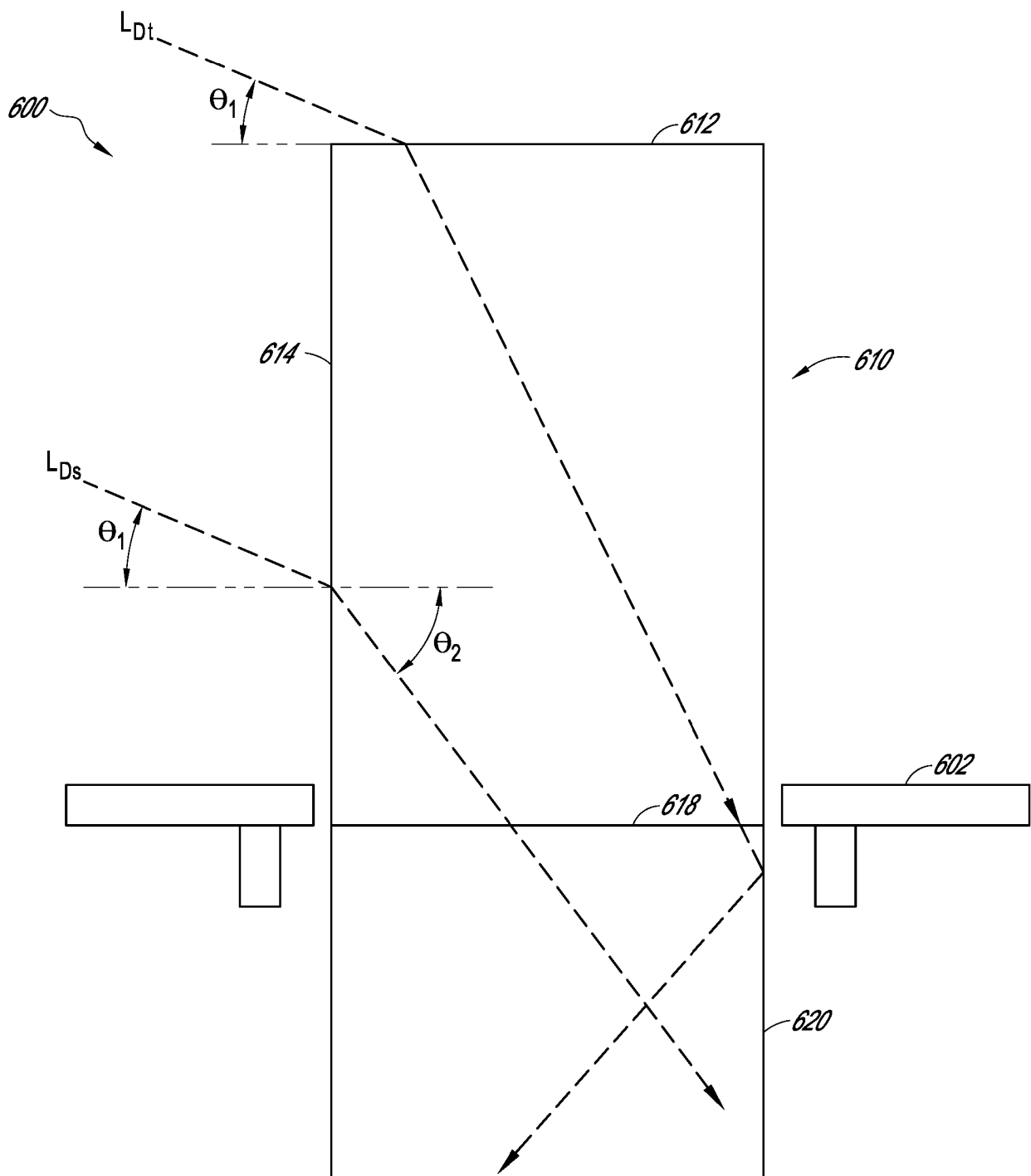

FIG. 6

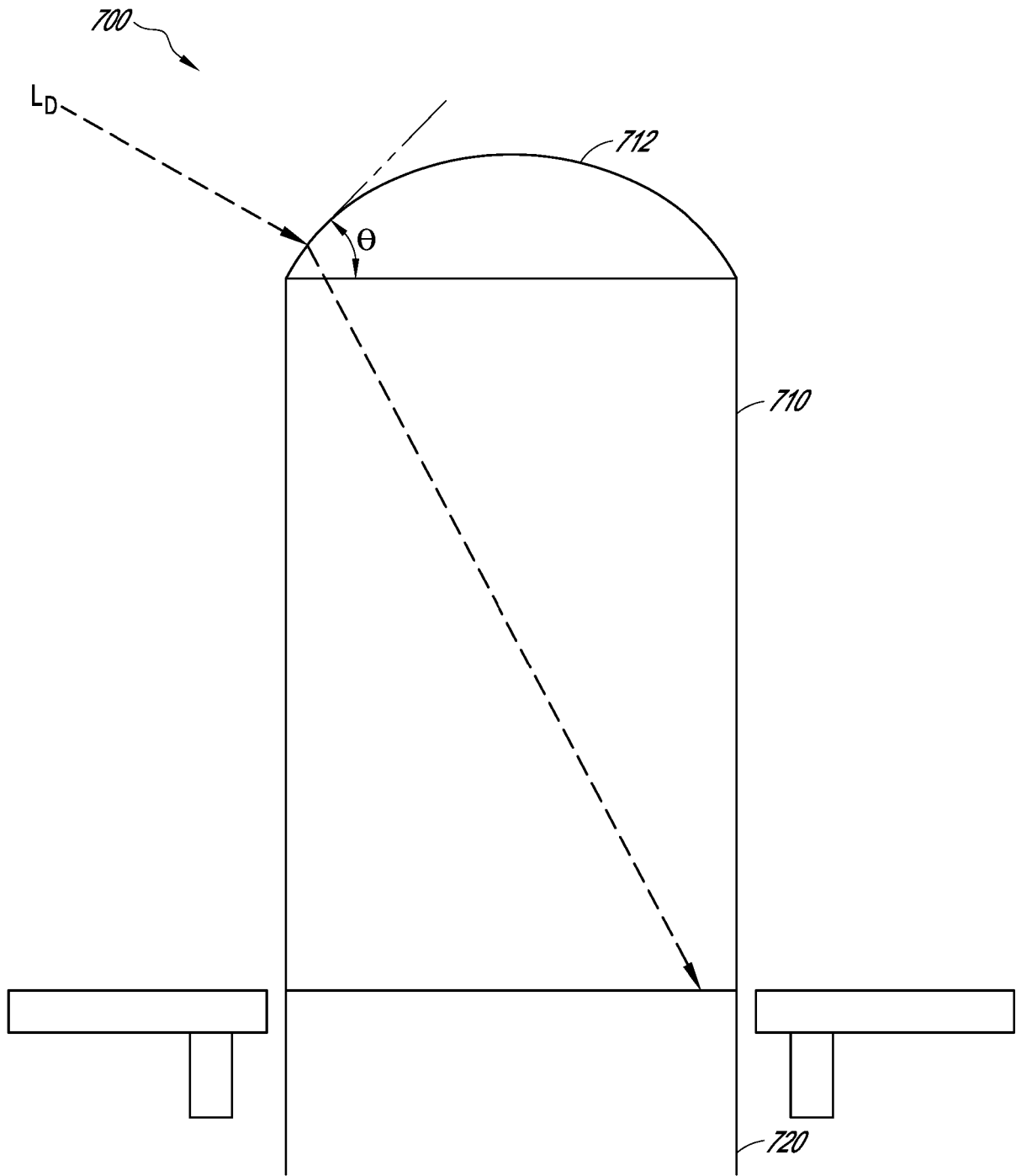

FIG. 7

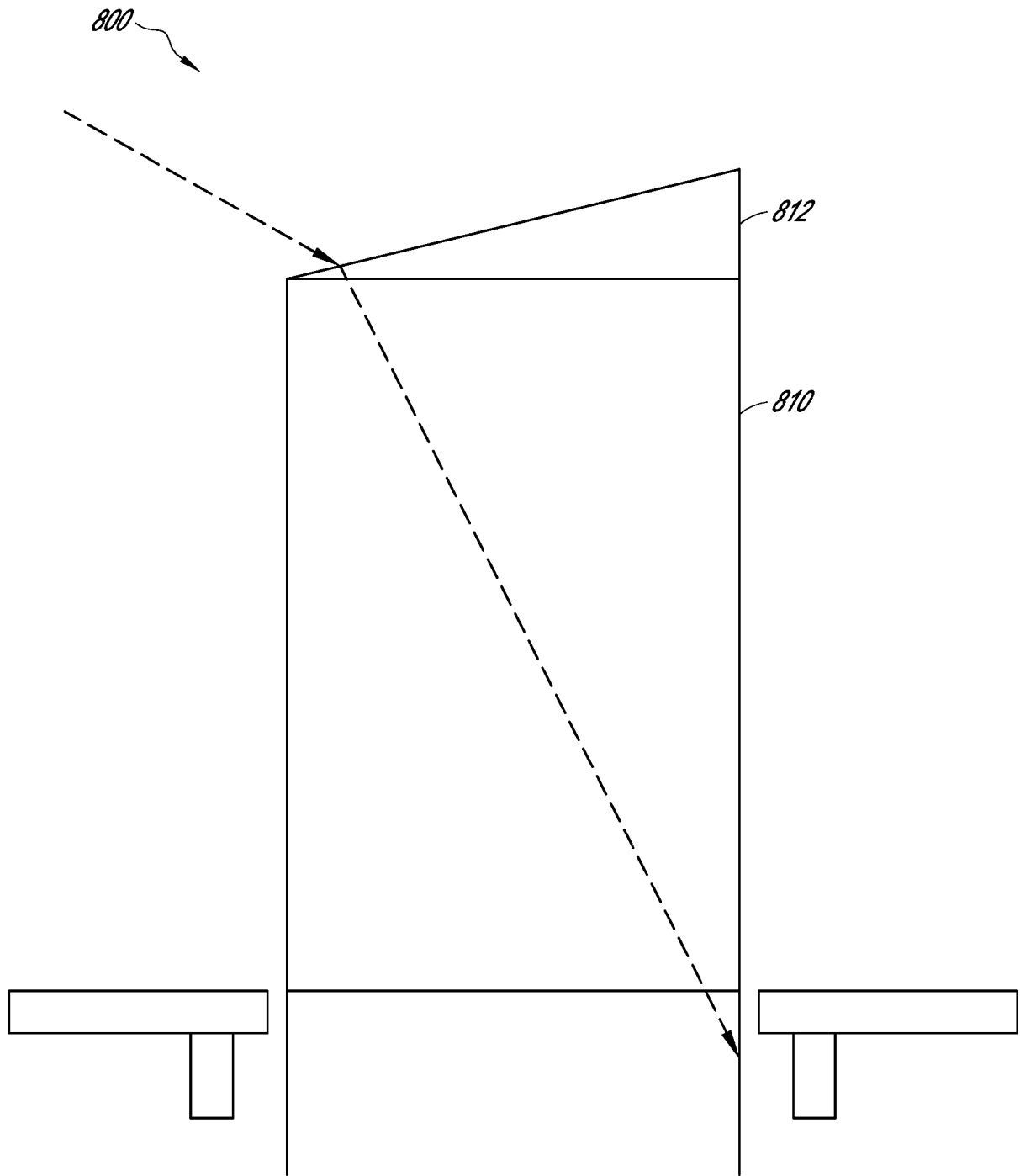

FIG. 8

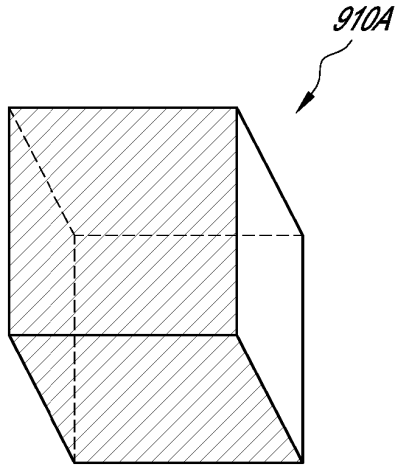

FIG. 9A

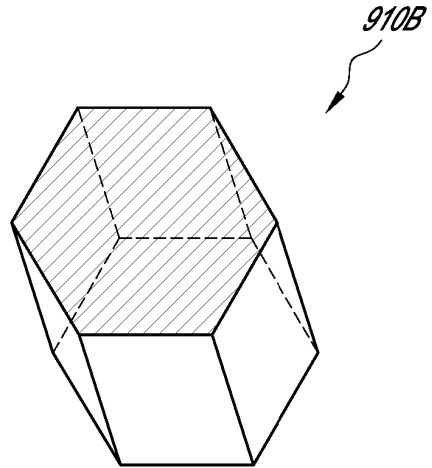

FIG. 9B

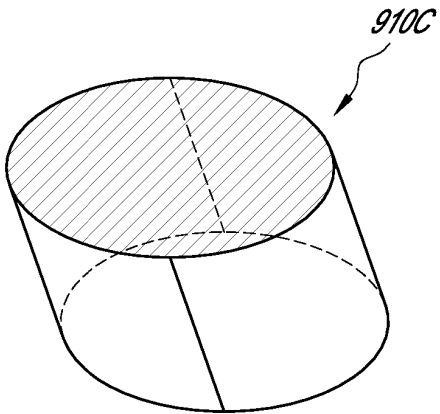

FIG. 9C

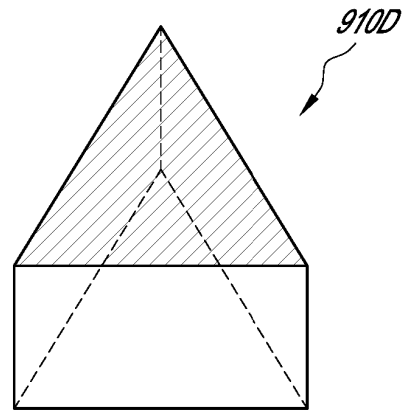

FIG. 9D

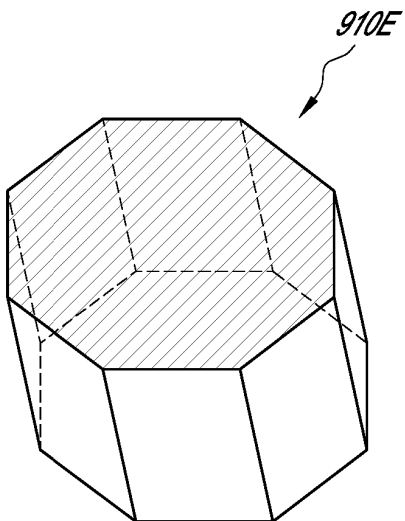

FIG. 9E

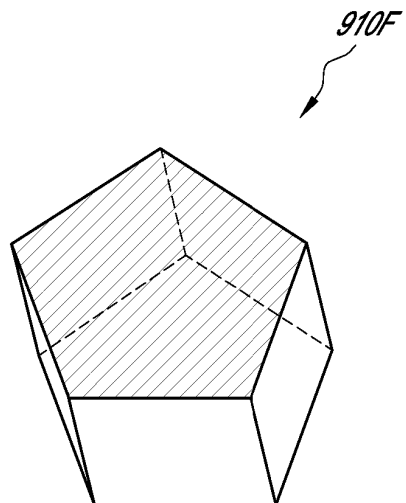

FIG. 9F

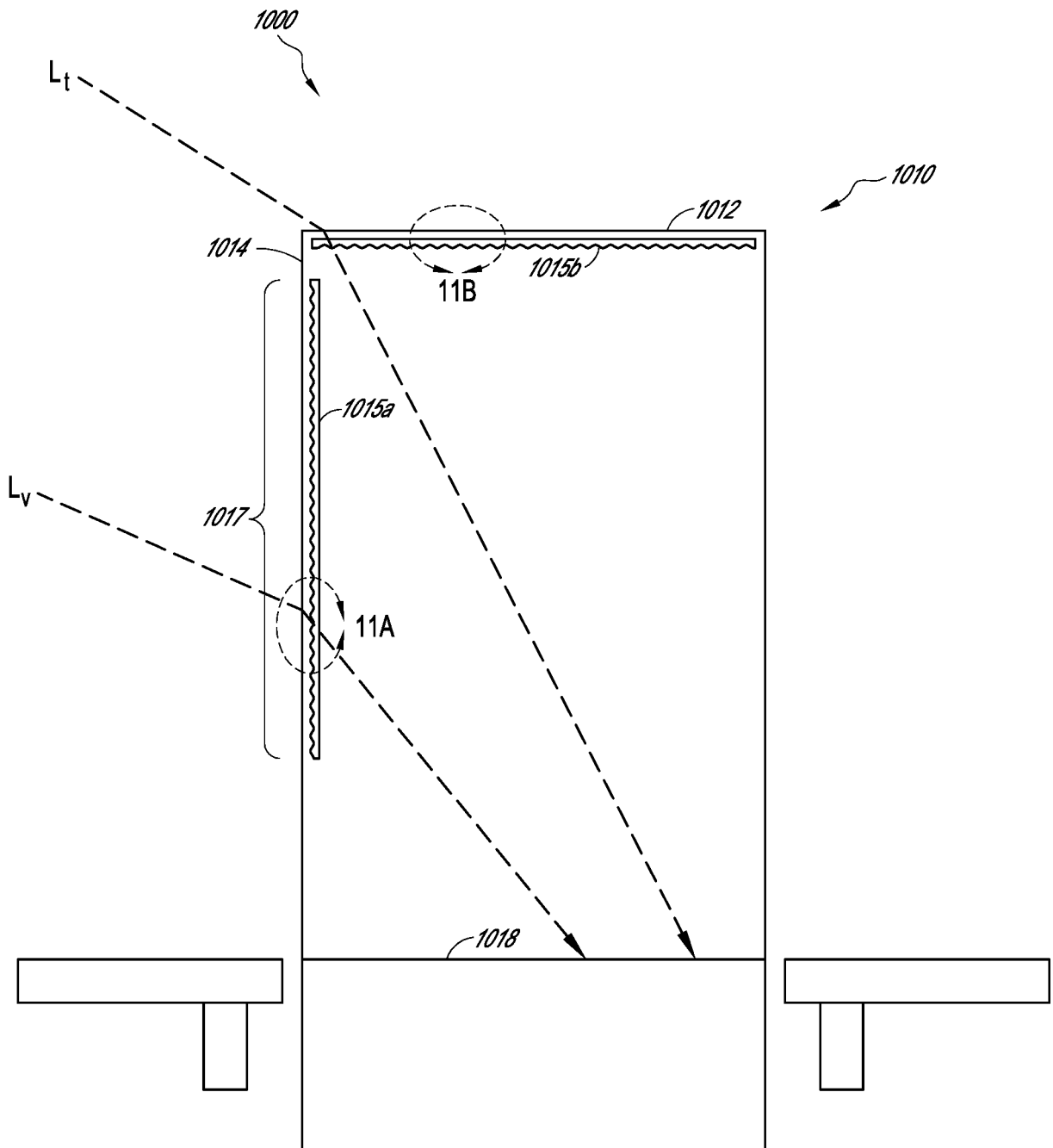

FIG. 10A

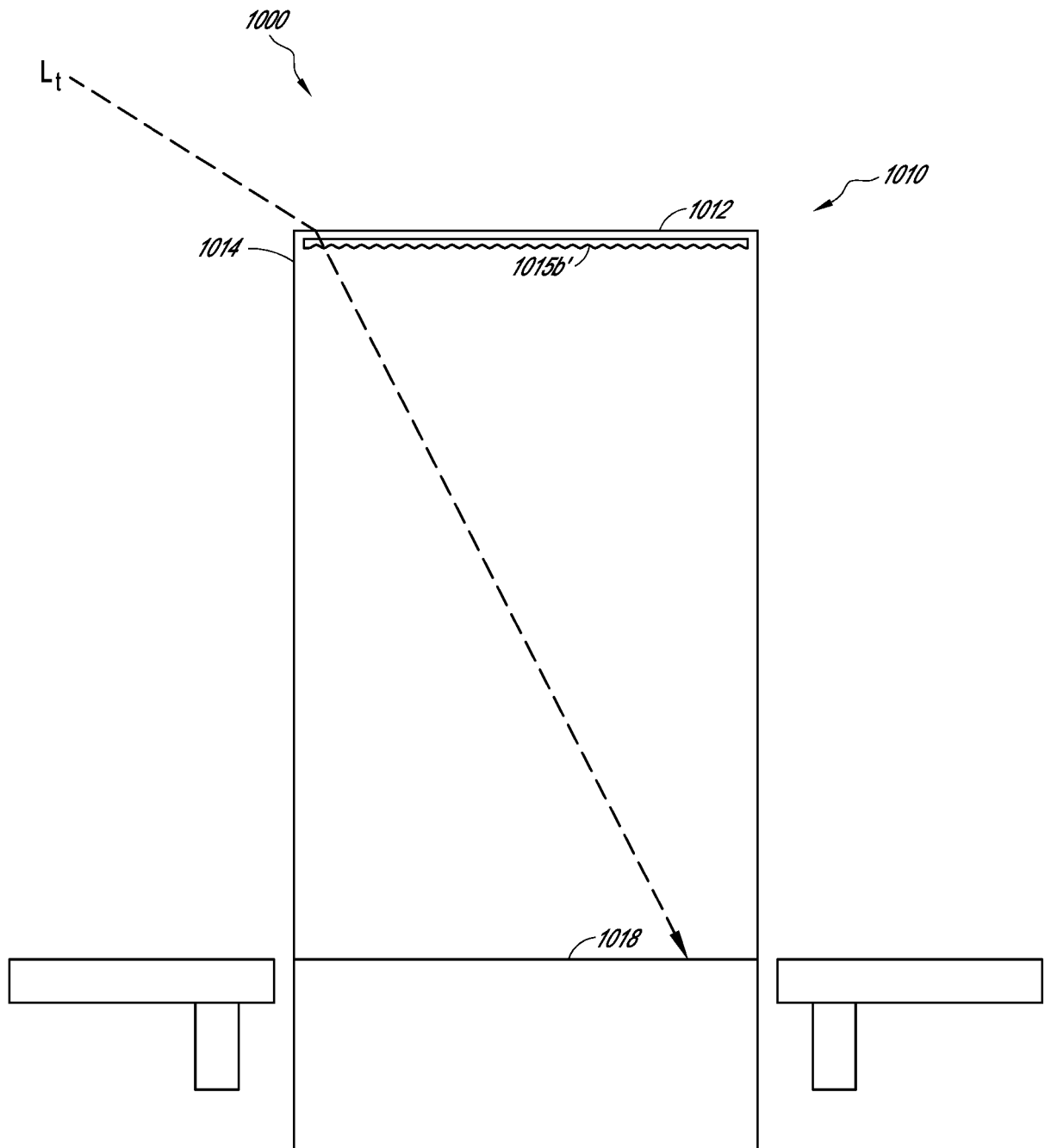

FIG. 10B

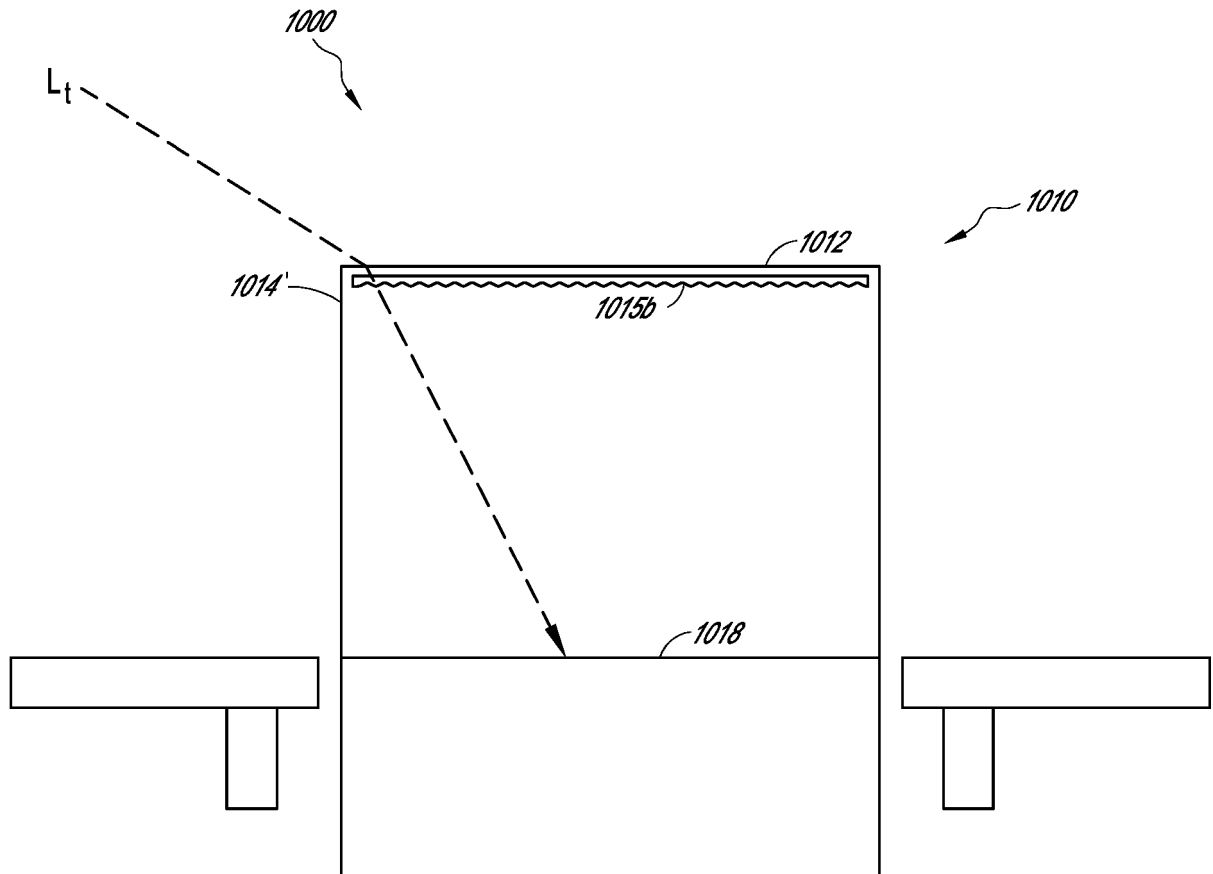

FIG. 10C

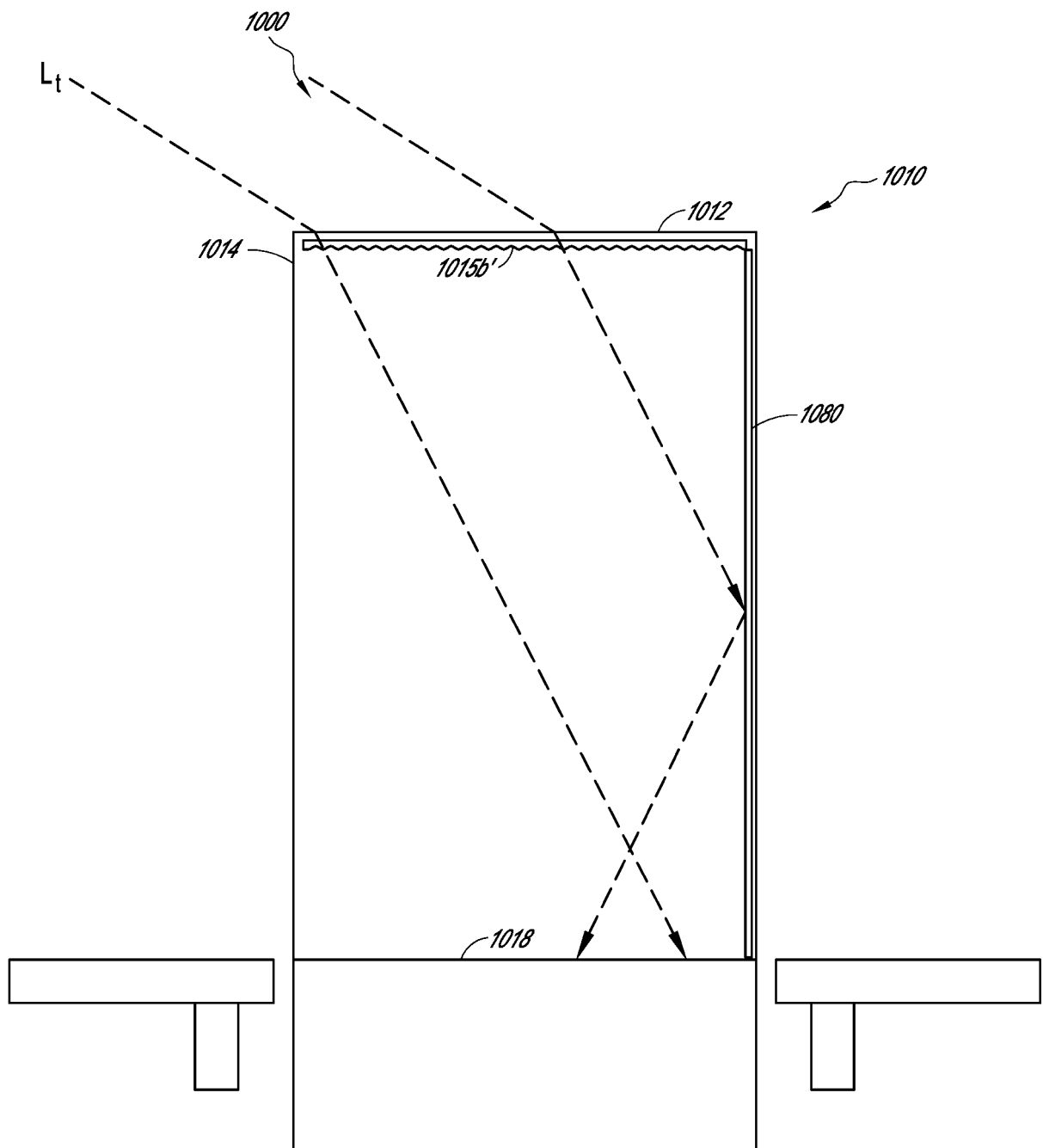

FIG. 10D

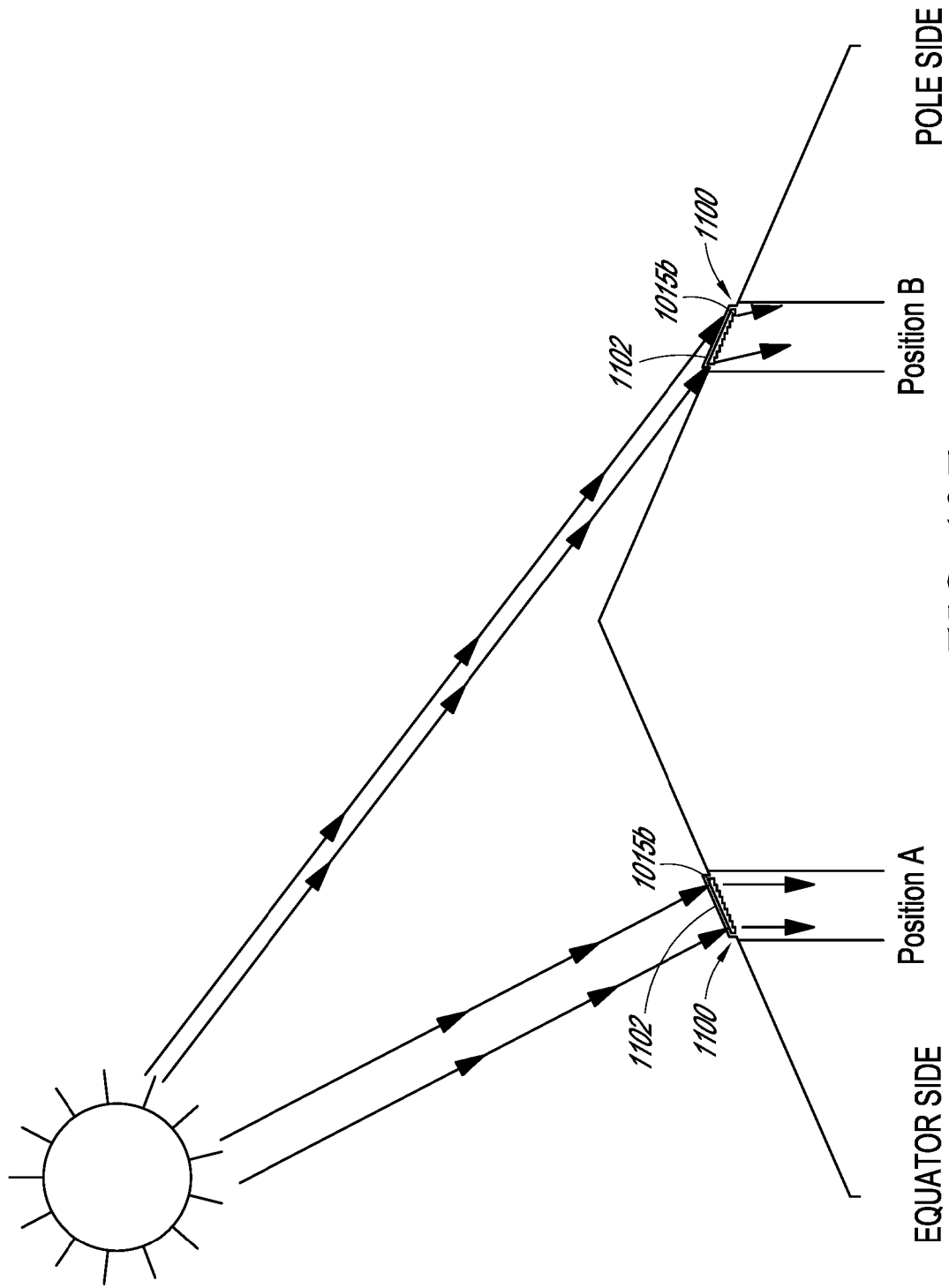

FIG. 10E

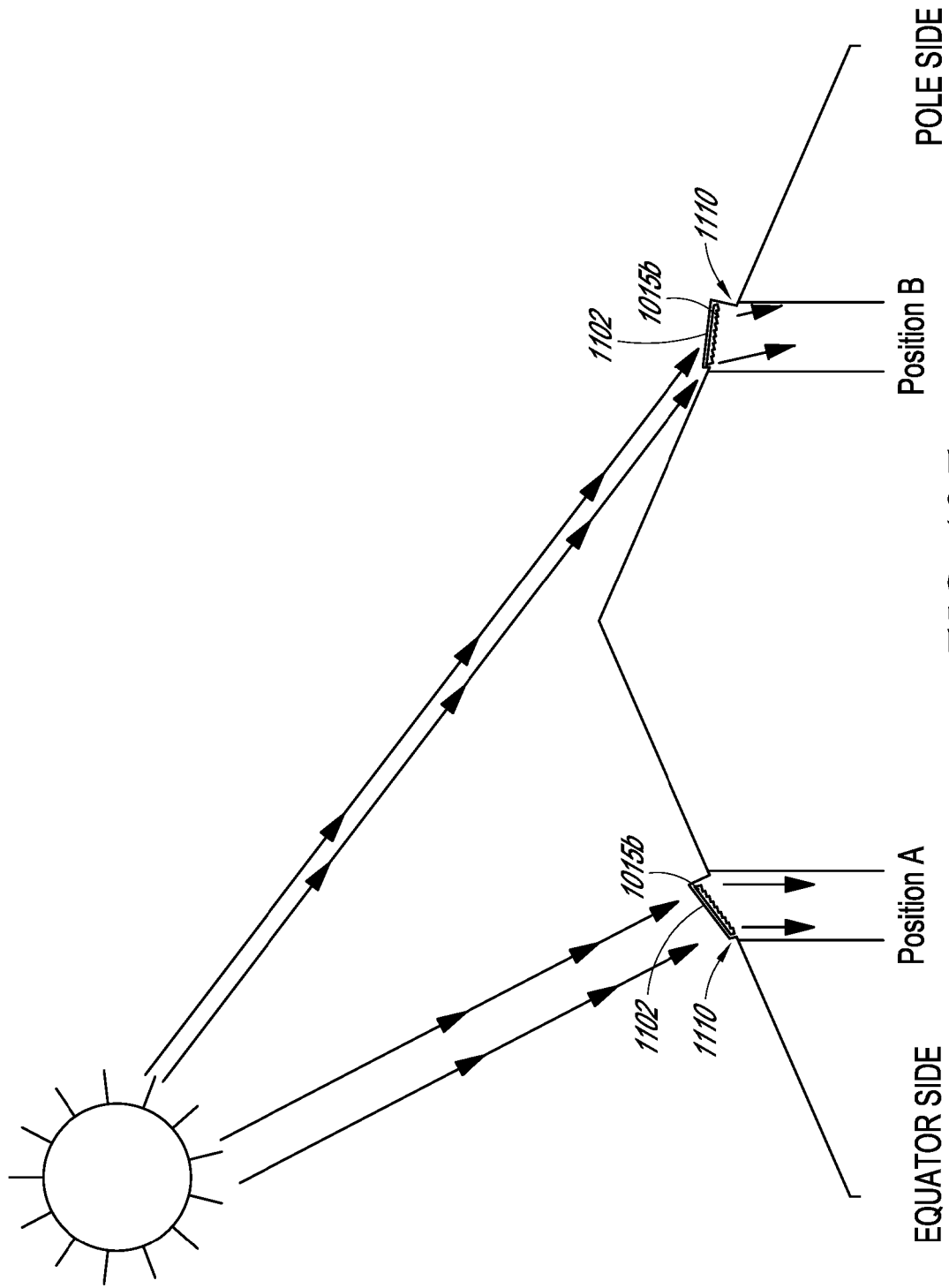

FIG. 10F

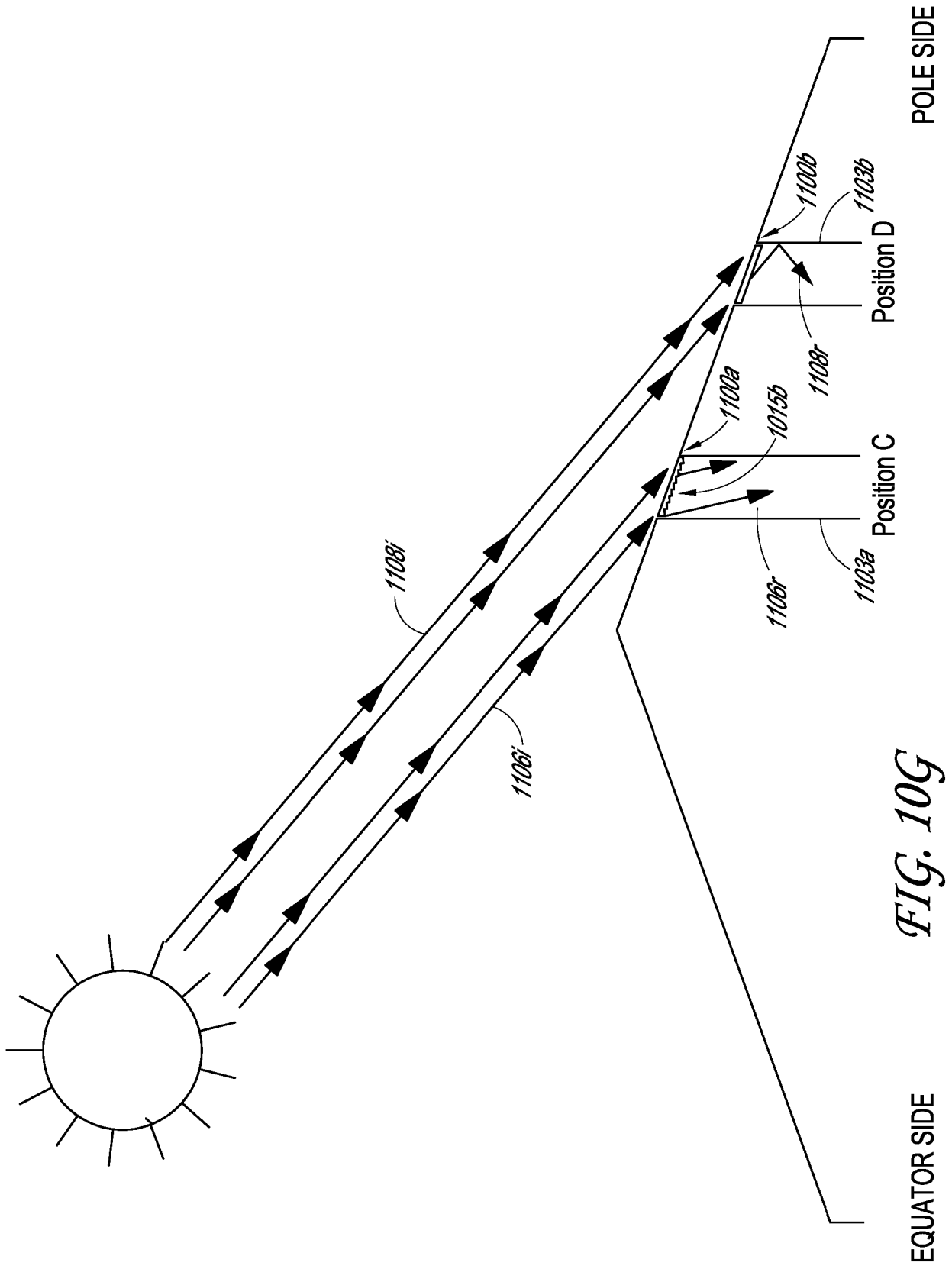

FIG. 10G

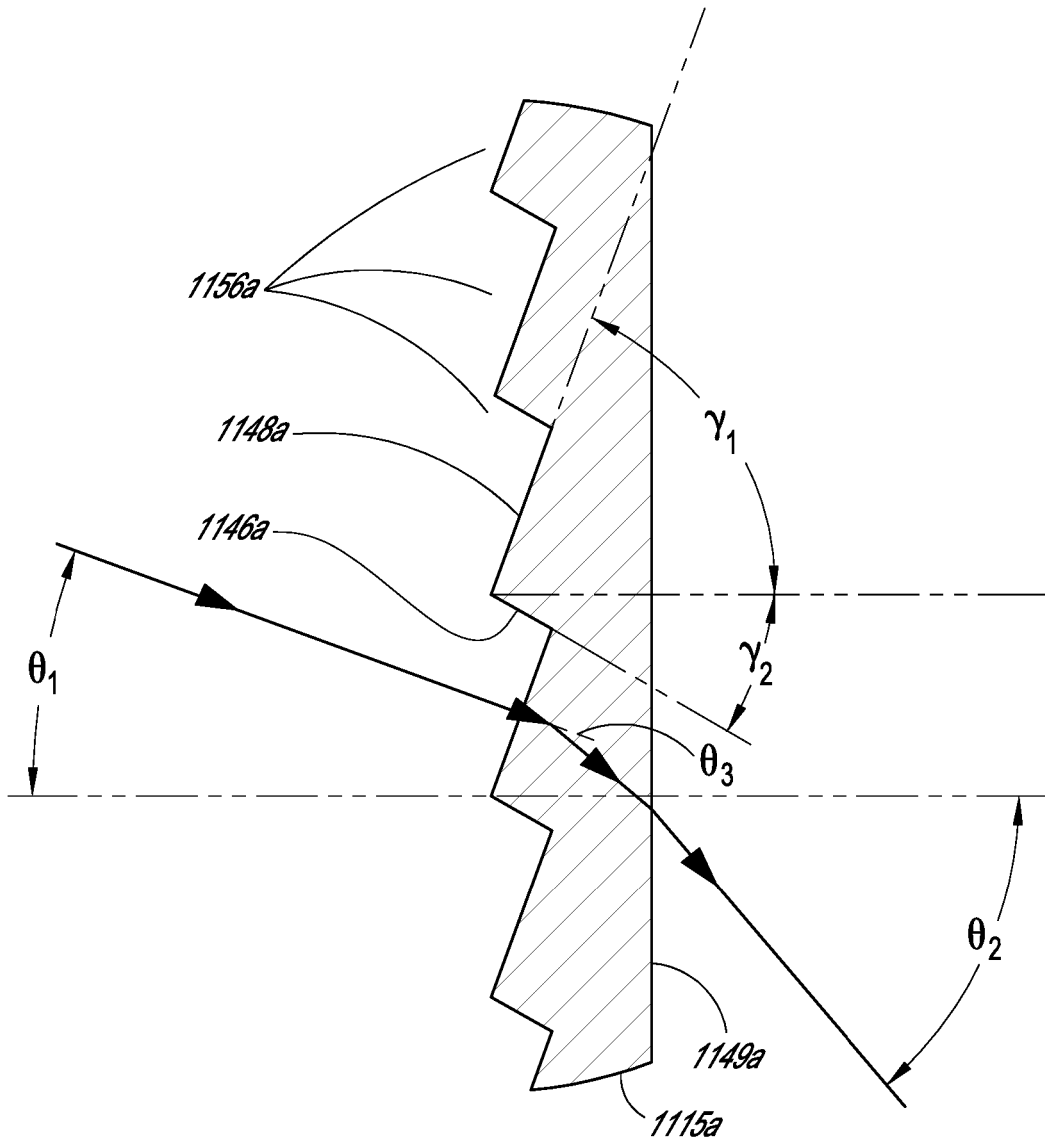

FIG. 11A

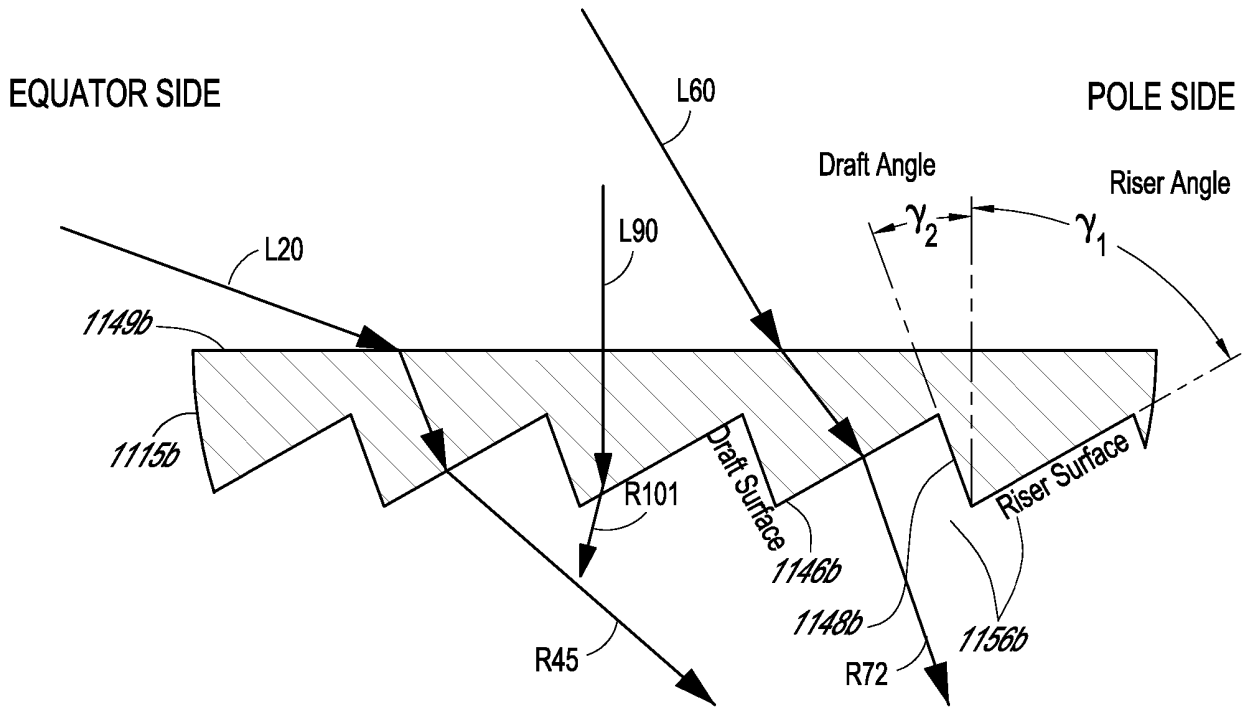

FIG. 11B

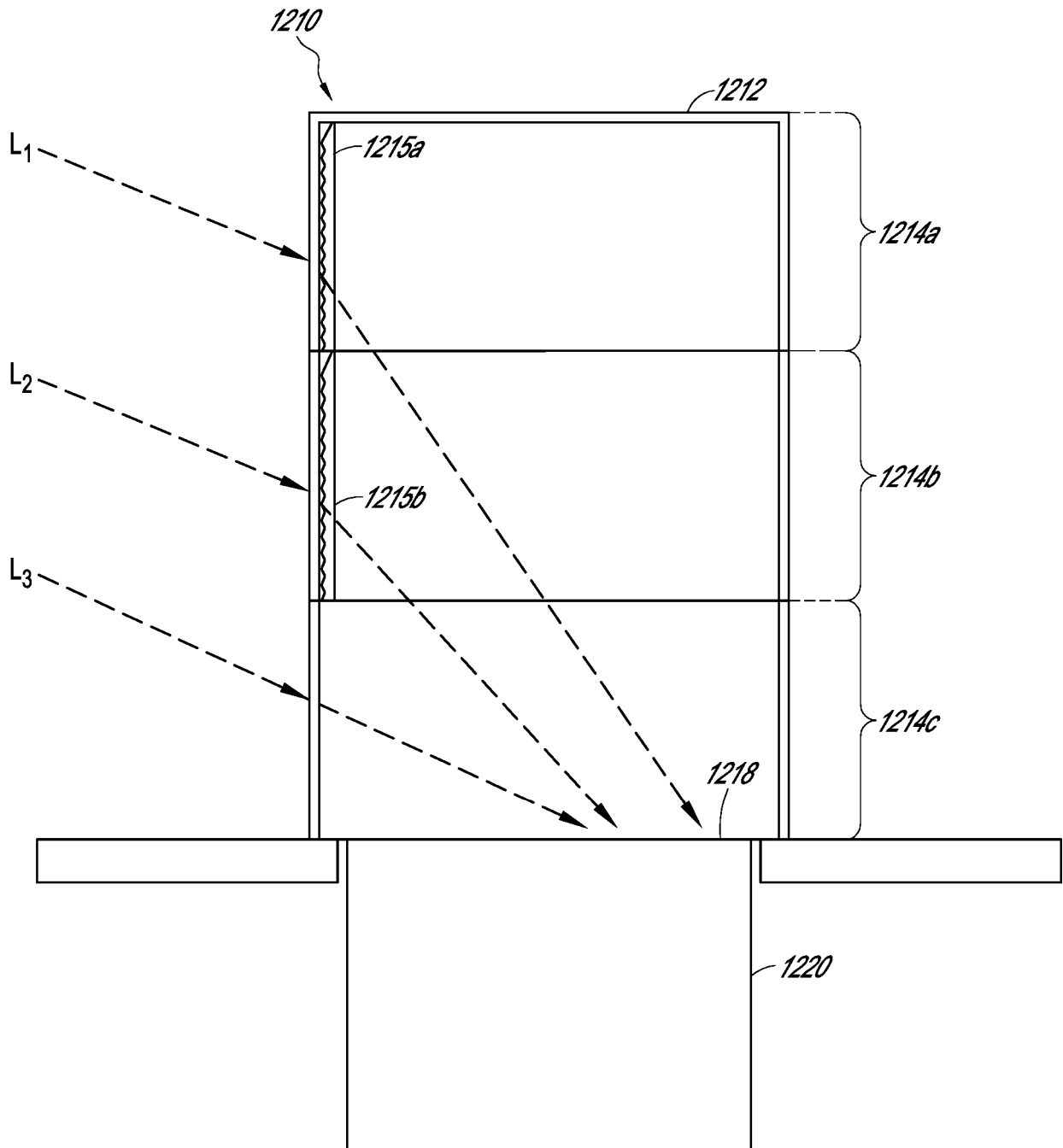
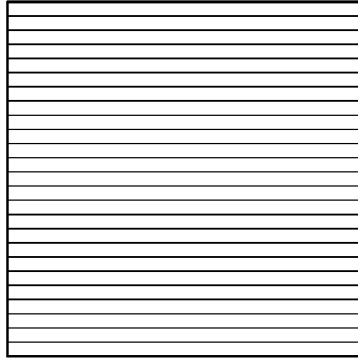
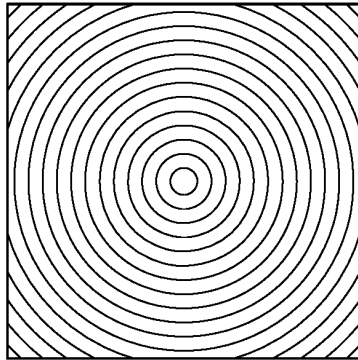

FIG. 12



1310a

FIG. 13A



1310b

FIG. 13B

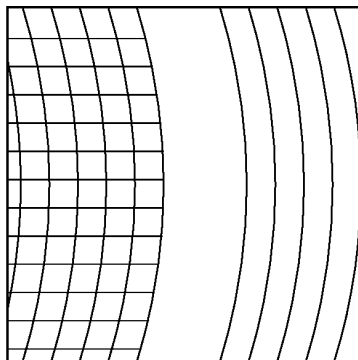

1310c

FIG. 13C

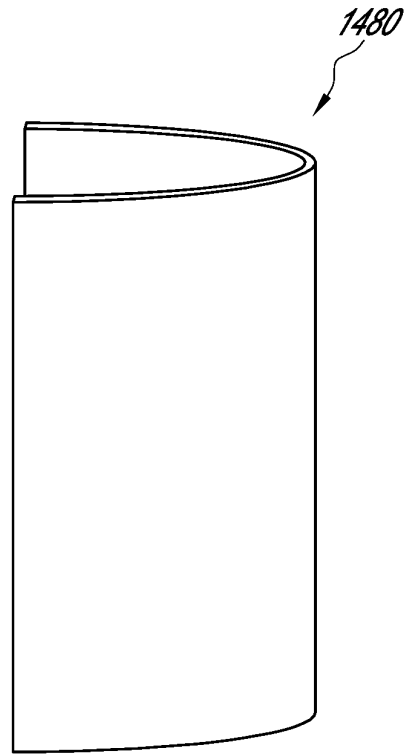

FIG. 14A

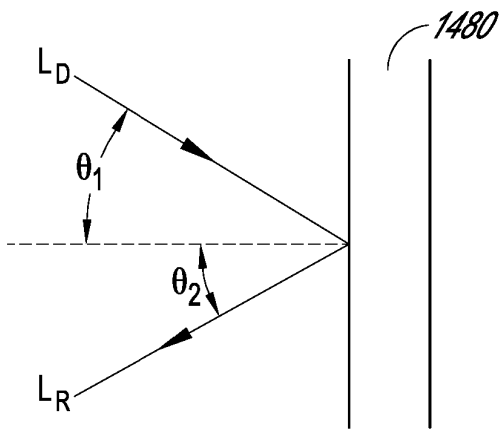

FIG. 14C

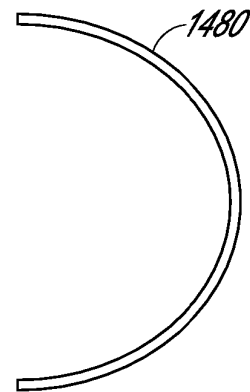

FIG. 14B

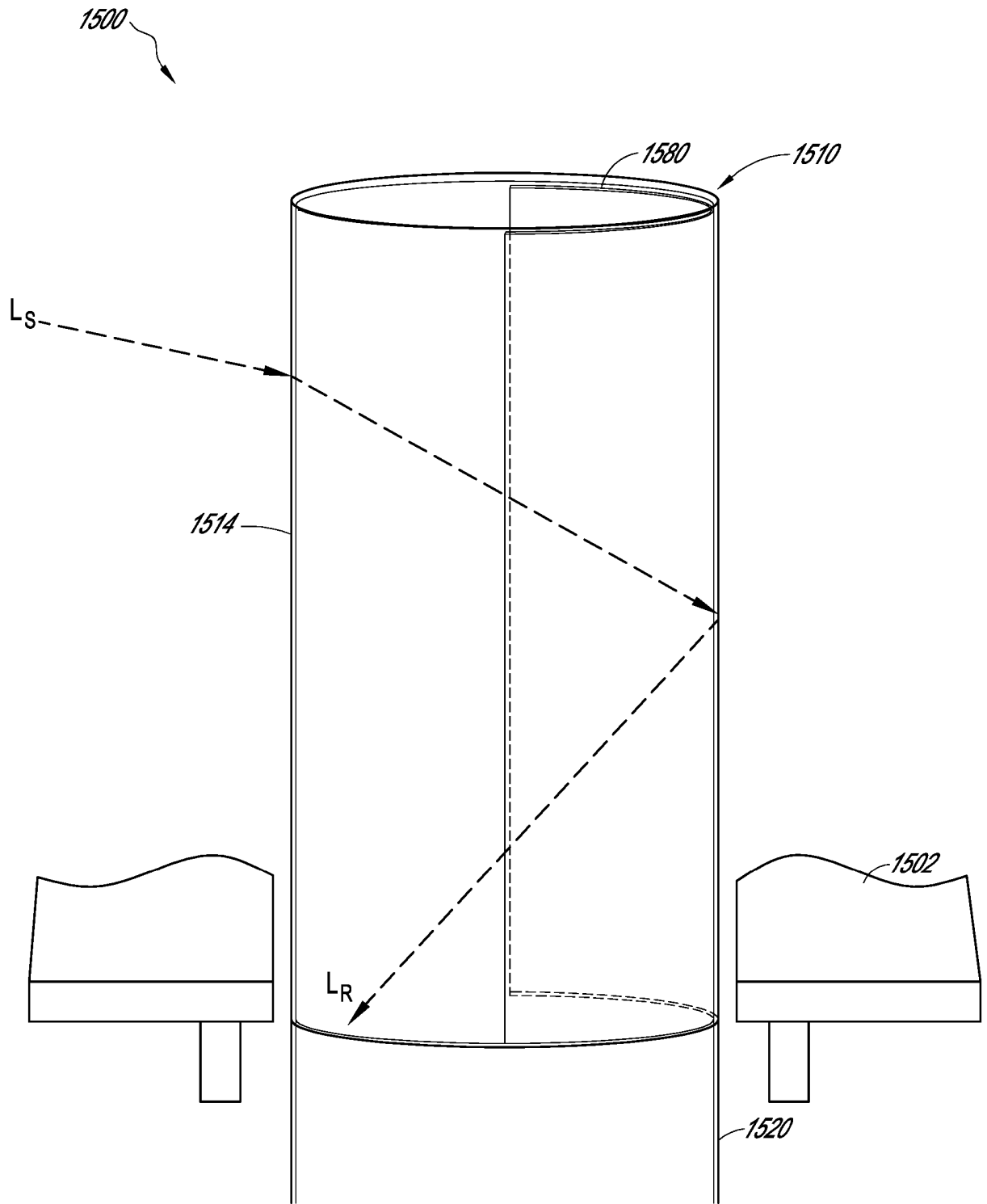

FIG. 15

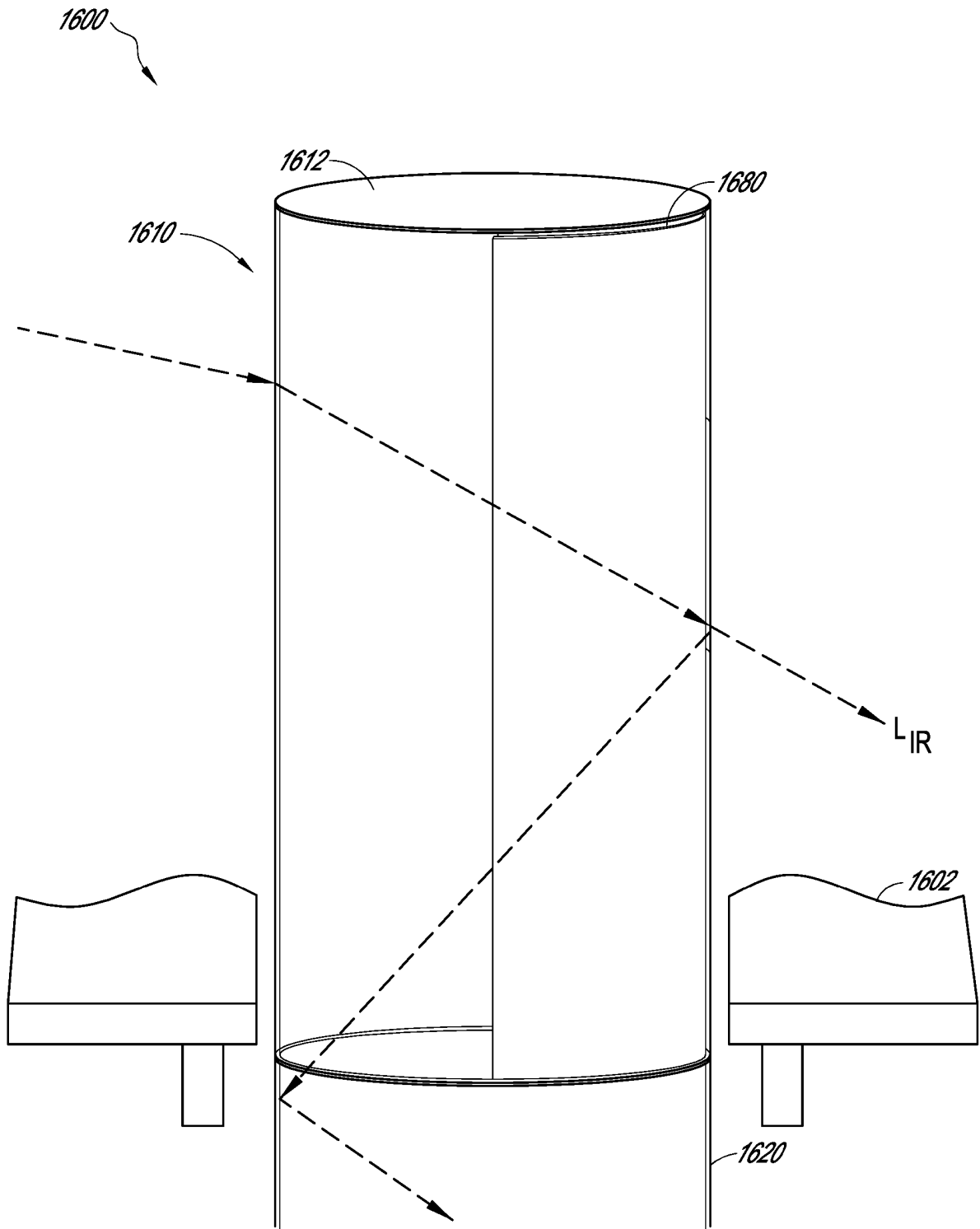

FIG. 16

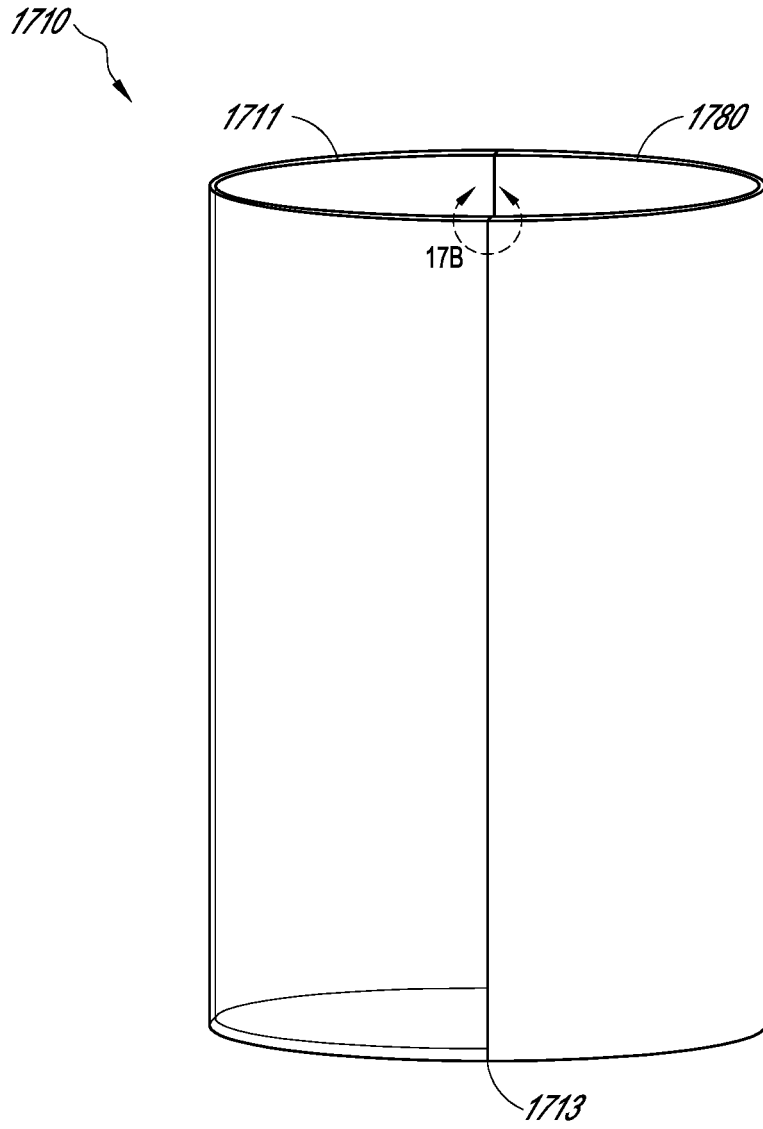

FIG. 17A

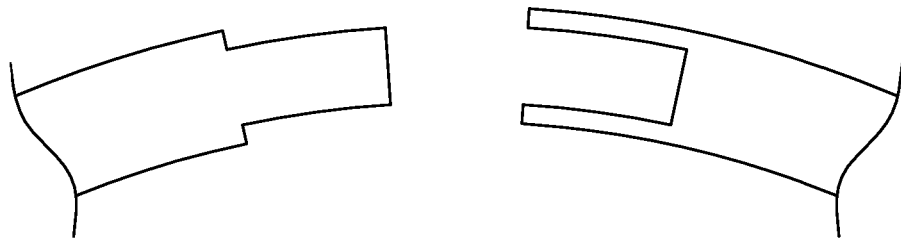

FIG. 17B

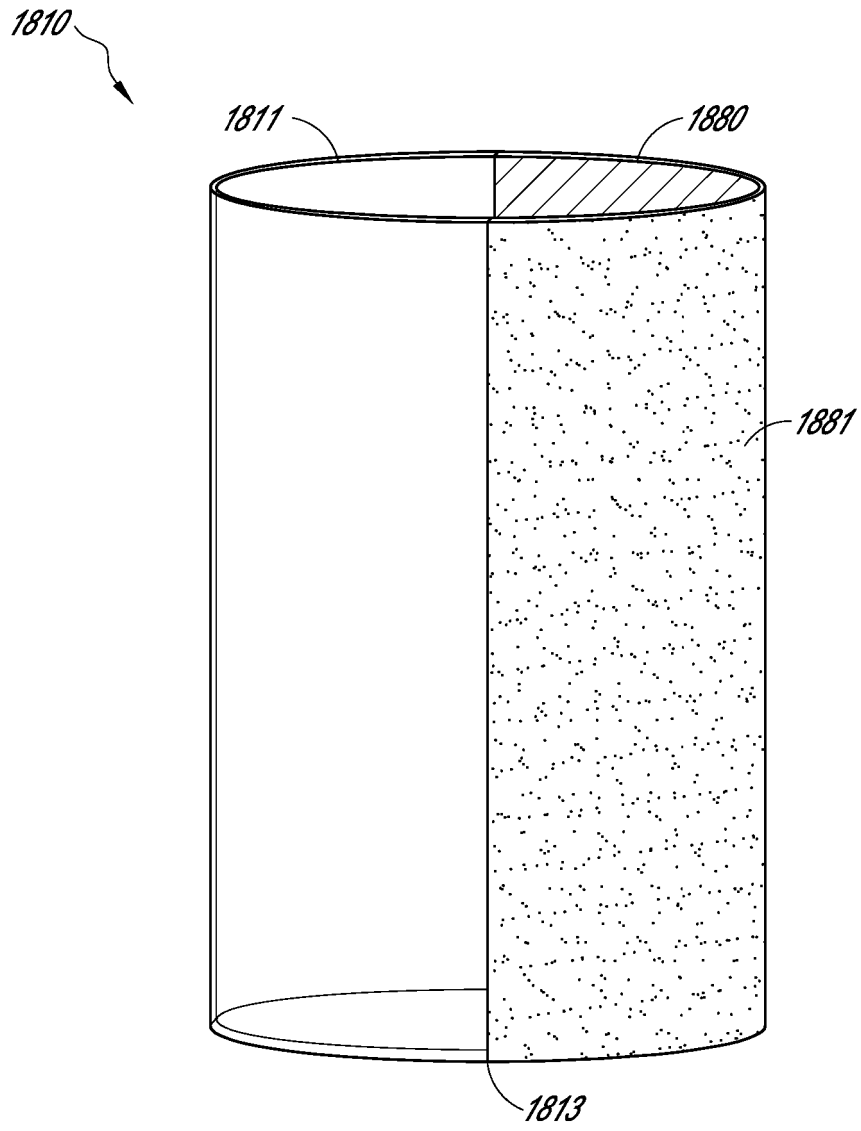

FIG. 18

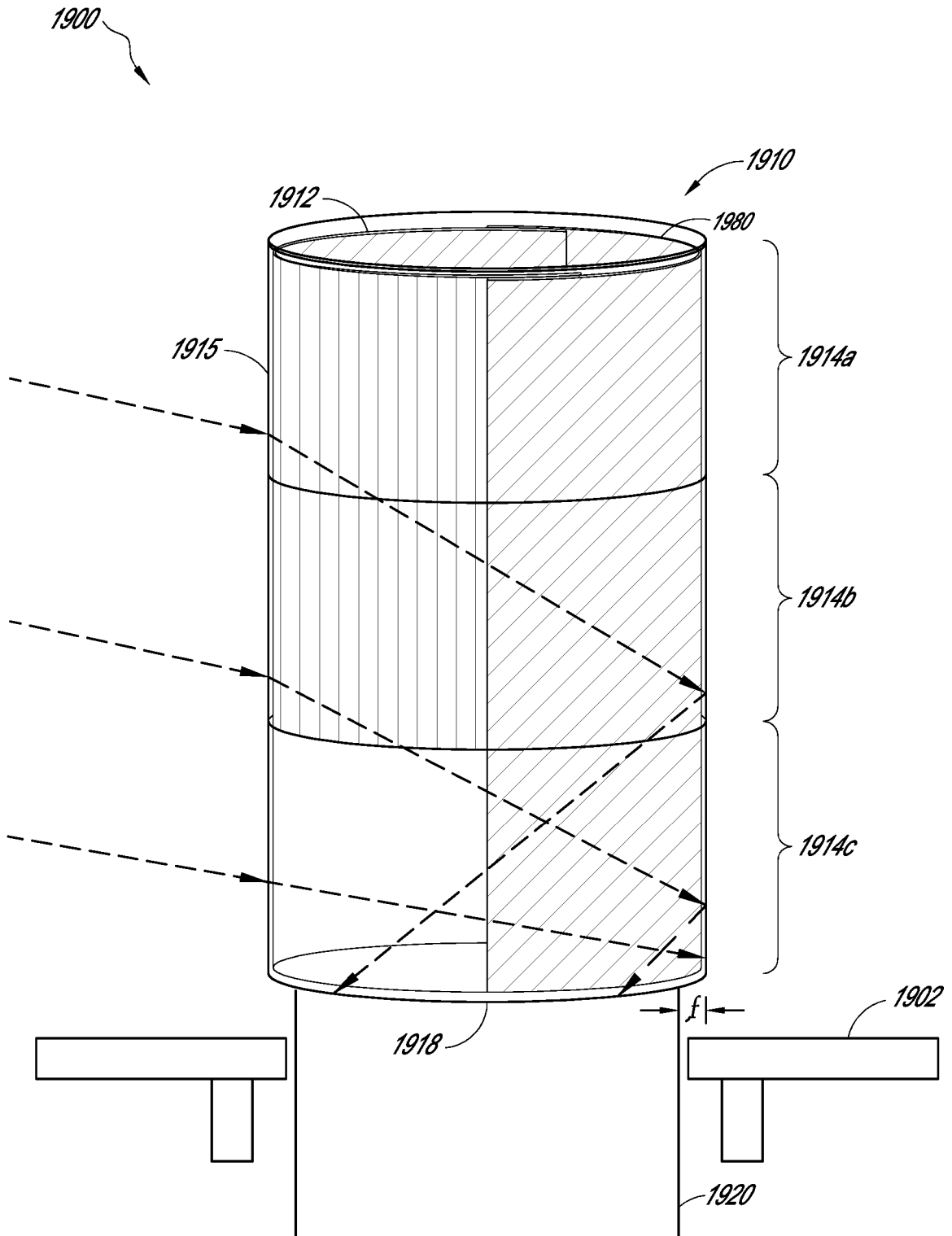

FIG. 19

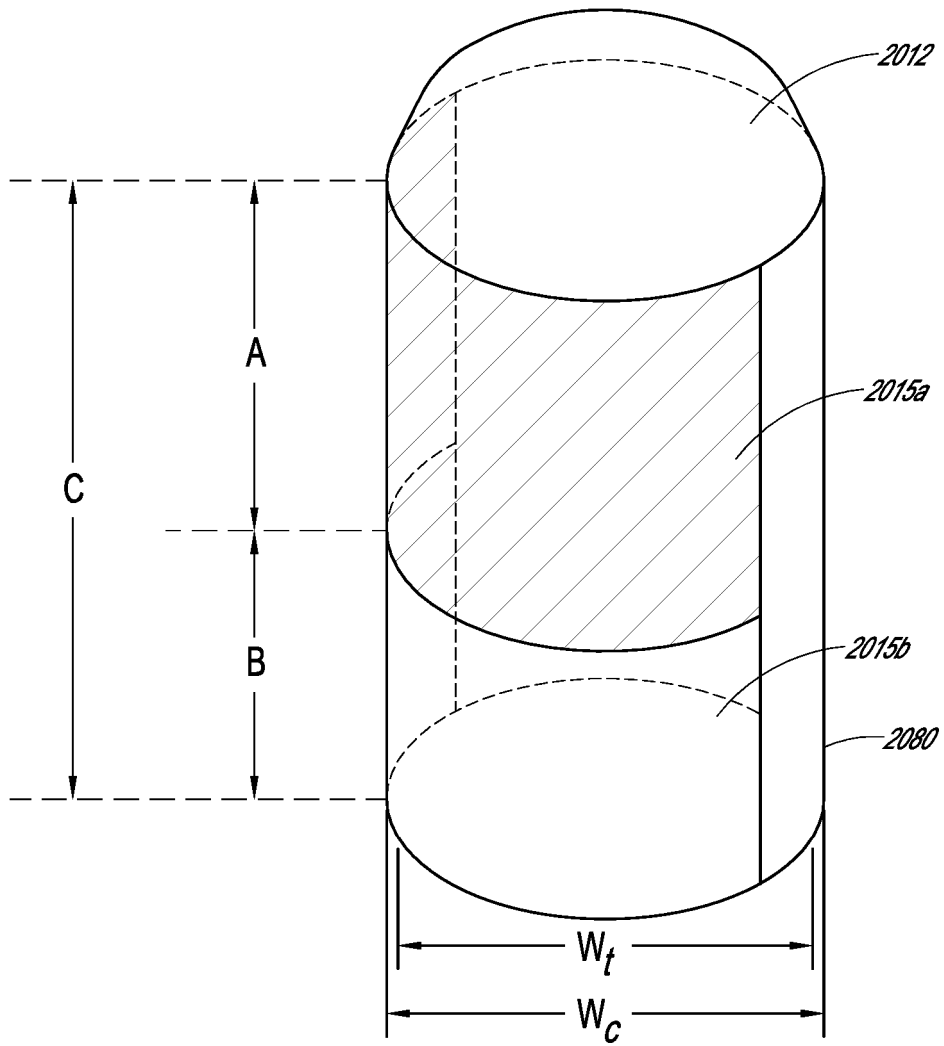

FIG. 20

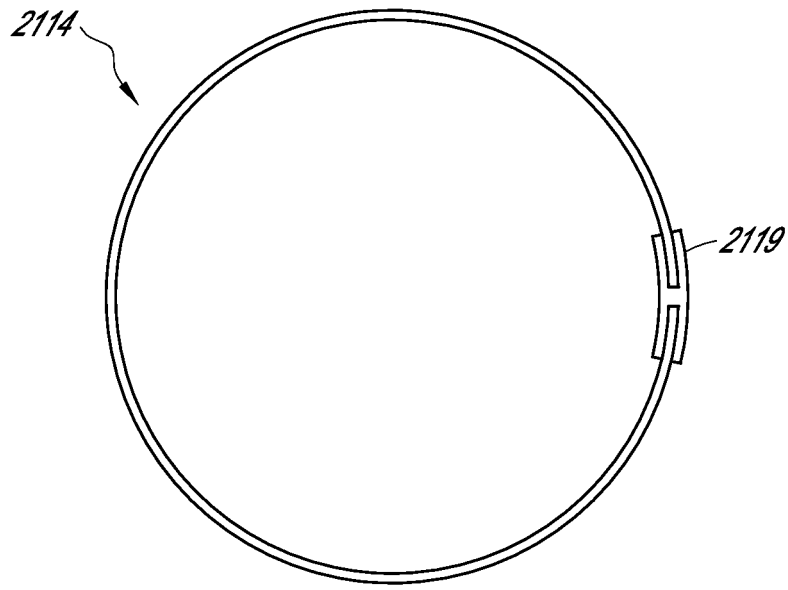

FIG. 21A

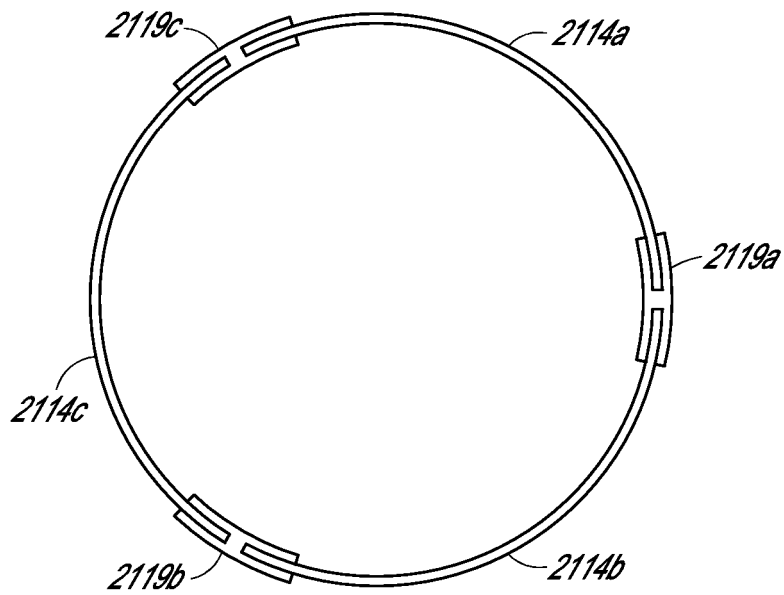
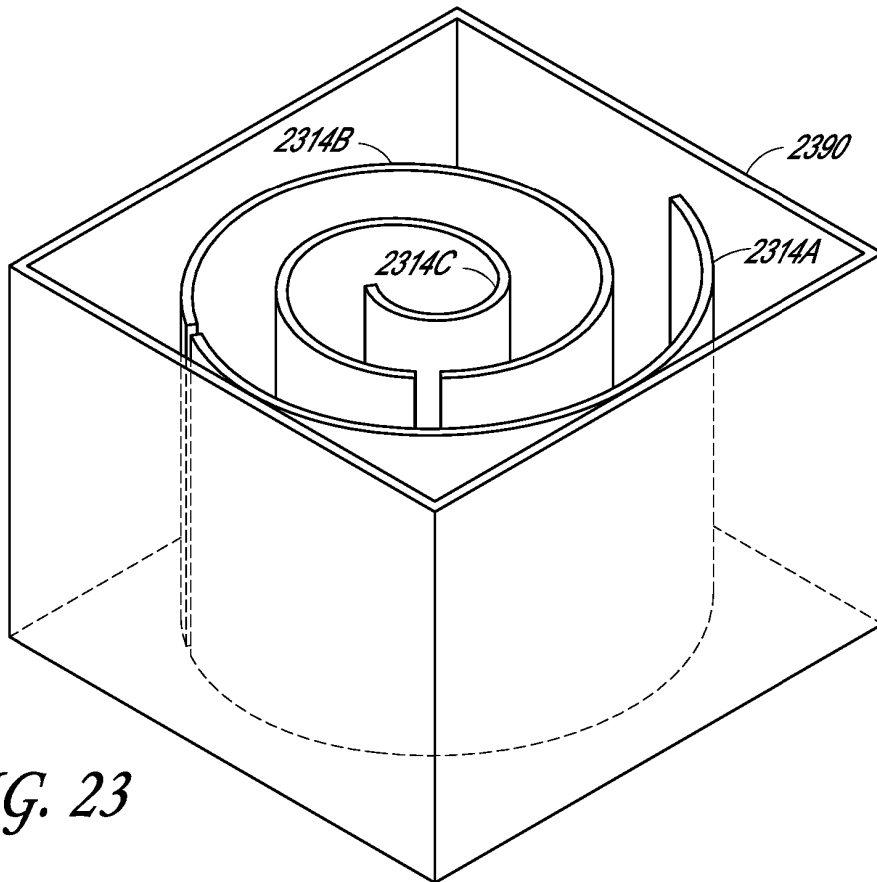
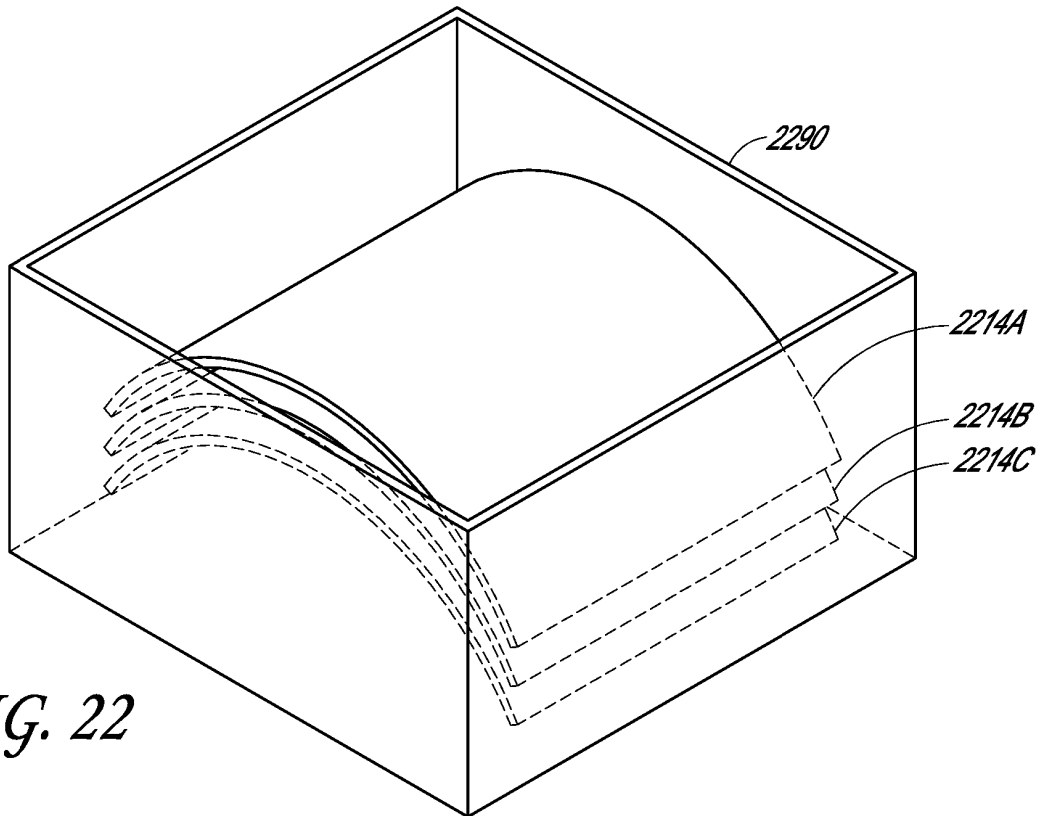

FIG. 21B



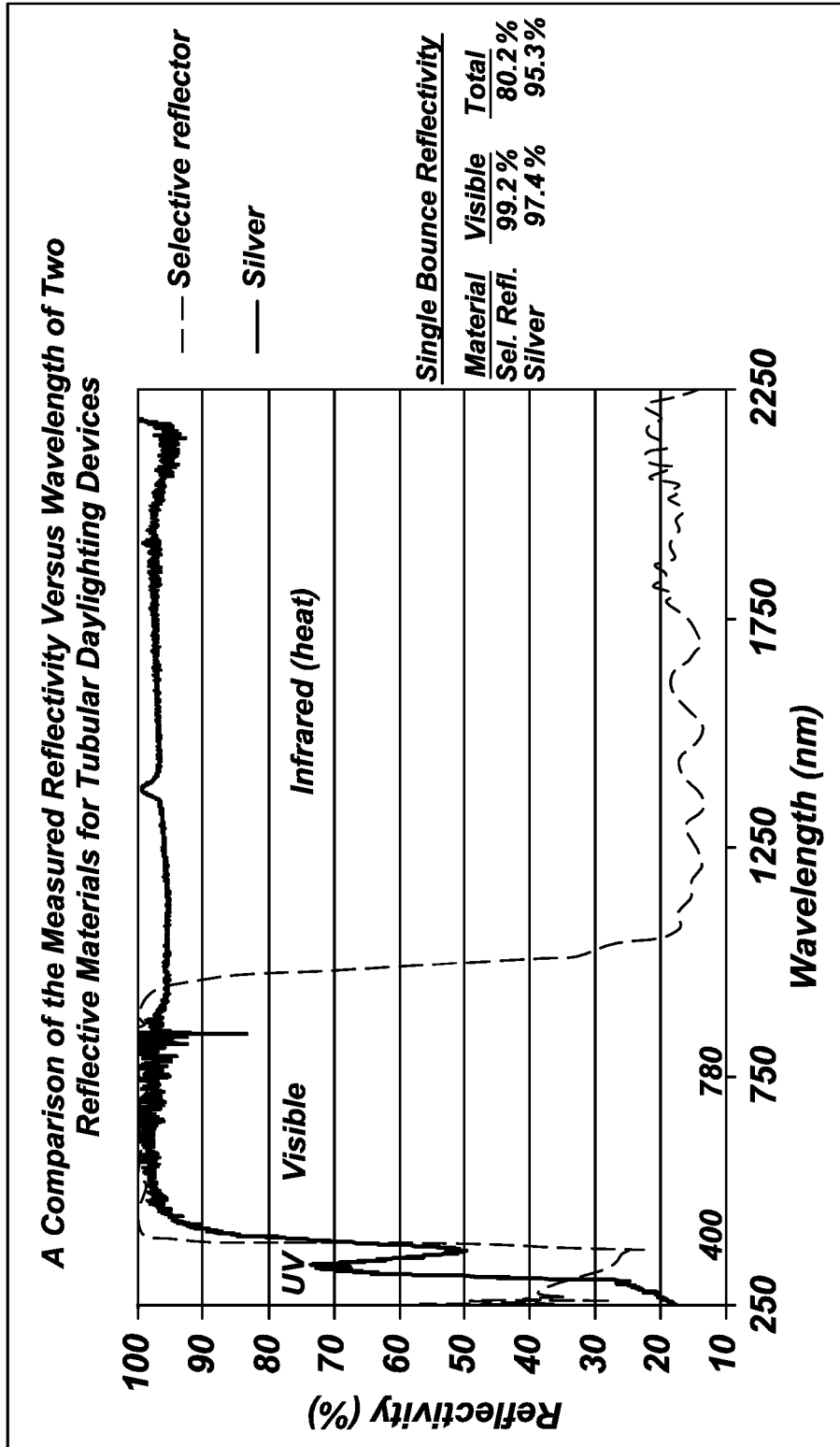

FIG. 24

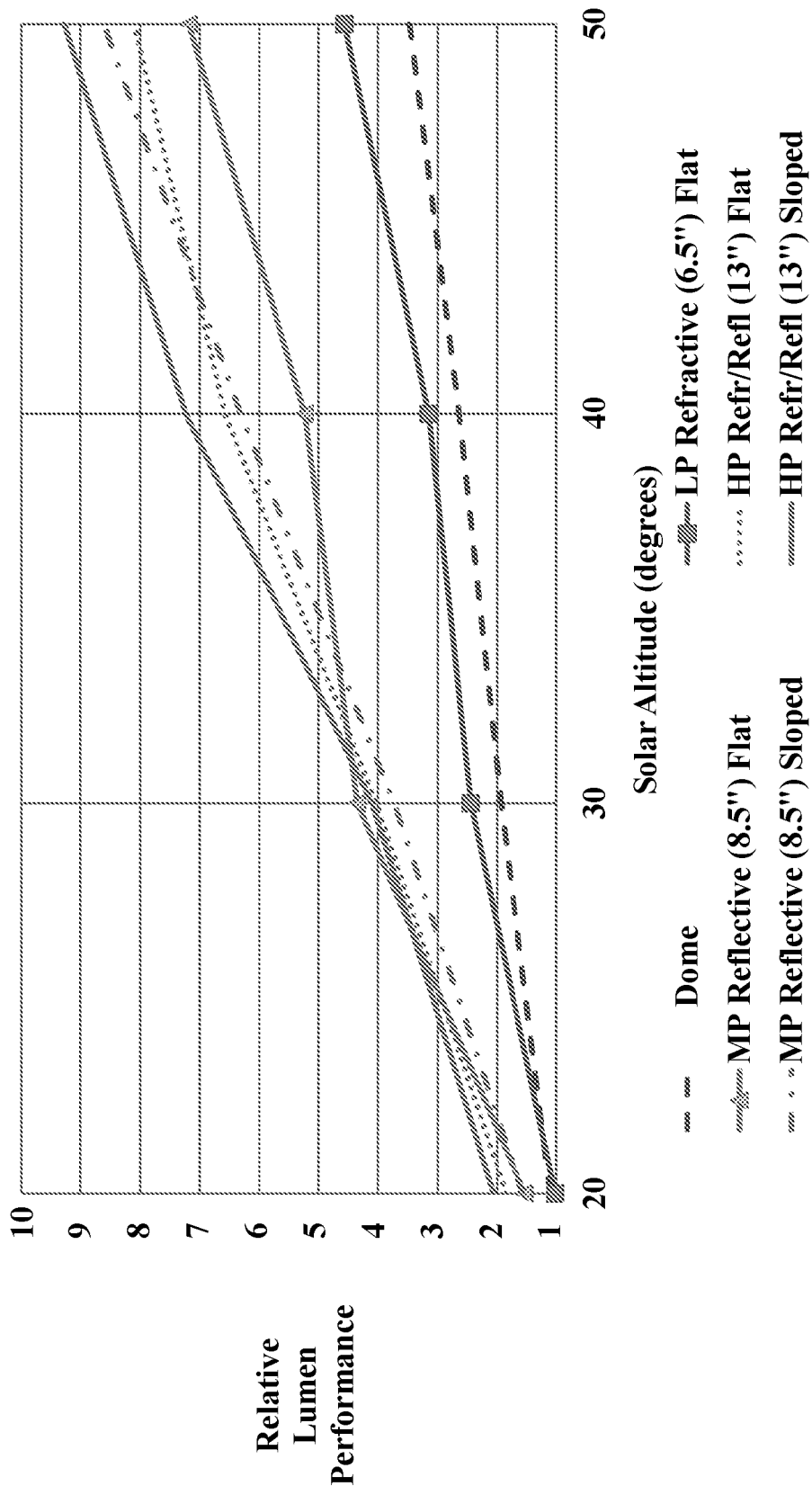

FIG. 25

REFERENCES CITED IN THE DESCRIPTION

This list of references cited by the applicant is for the reader's convenience only. It does not form part of the European patent document. Even though great care has been taken in compiling the references, errors or omissions cannot be excluded and the EPO disclaims all liability in this regard.

Patent documents cited in the description

- US 2993409 A, BOYD ROBERT A [0003]
- JP H11167084 A [0004]
- US 2015167305 A1, KASTNER STEVE ROY [0005]
- US 20110289869 [0076]
- US 7546709 B [0080]
- US 20130083554 A [0105]
- US 8601757 B [0110]