

(19)



(11)

EP 3 546 694 A1

(12)

EUROPEAN PATENT APPLICATION

(43) Date of publication:
02.10.2019 Bulletin 2019/40

(51) Int Cl.:
E21B 27/00 (2006.01) E21B 37/00 (2006.01)

(21) Application number: **18164037.6**

(22) Date of filing: **26.03.2018**

(84) Designated Contracting States:
AL AT BE BG CH CY CZ DE DK EE ES FI FR GB GR HR HU IE IS IT LI LT LU LV MC MK MT NL NO PL PT RO RS SE SI SK SM TR
Designated Extension States:
BA ME
Designated Validation States:
KH MA MD TN

(72) Inventors:
• **PARKER, Todd**
CALGARY, Alberta T2P 0P7 (CA)
• **FENSKY, Charles**
CALGARY, Alberta T2P 0P7 (CA)

(74) Representative: **Argyma**
36, rue d'Alsace Lorraine
31000 Toulouse (FR)

(71) Applicant: **Blue Spark Energy Inc.**
Calgary, AB T2P 0P7 (CA)

(54) **DEVICE AND METHOD FOR COLLECTING DEBRIS OF DEPOSITS IN A WELLBORE**

(57) The invention relates to a collecting device (20) for collecting debris of deposits while said deposits are being removed from a wellbore wall or an equipment arranged in a wellbore of a subterranean formation in order to improve the recovery of formation fluids and/or gases, said collecting device being configured for being attached to a cleaning device, said cleaning device being configured for removing deposits from a wellbore wall or an equipment arranged in a wellbore. The collecting device comprises a deflector (210), configured for deflecting falling debris of deposits while said deposits are being removed from said wellbore wall or said equipment, and a debris storing module (220), connected to said deflector (210) for collecting and storing debris deflected by said deflector (210).

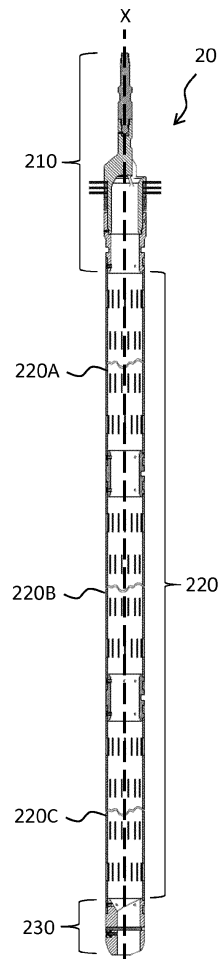

FIGURE 2

EP 3 546 694 A1

Description**FIELD OF THE INVENTION**

[0001] The field of the invention relates to well boring and, more particularly, to a device and a method for removing deposits from a wellbore wall or an equipment arranged in a wellbore of a subterranean formation in order to improve the recovery of formation fluids and/or gases. The device and method according to the invention may advantageously be used to remove deposits from e.g. a wellbore wall, a casing, a tubing or a well completion equipment.

BACKGROUND OF THE INVENTION

[0002] In the art of well boring, a borehole is drilled into the earth through an oil or gas producing subterranean formation or, for some purposes, through a water bearing formation or a formation into which water or gas or other liquids are to be injected.

[0003] Completion of a well may be carried out in a number of ways dependent upon the nature of the formation of interest. In particular, it is known to arrange a casing into the wellbore to control formation elements. Once installed into the wellbore, the casing is then perforated in a plurality of areas for allowing the passage of oil and/or gas from the formation into the casing. In order to produce formation fluids or gases, completion strings are arranged in the borehole. Such a completion string generally comes as a production tubing which comprises a plurality of different equipment such as e.g. safety valves, sliding side doors, side pocket mandrels, etc.

[0004] In any event, after a period of production, injection or transportation of fluids or gases, there is a tendency for the wellbore wall and/or different wellbore equipment to become plugged with various types of deposits like e.g. residues. For example, organic residues like scale, paraffin, asphalts and other gummy residues of petroleum origin often cause plugging problems.

[0005] Usually these deposits can cause significant problems, because of their composition and the fact that they can precipitate under certain conditions (pressure, temperature, composition). These materials of mineral or organic origins either together with chemicals from water, normally produced with the oil, such as calcium carbonate, calcium sulfate, barium sulfate, sulfur and the like, or such chemicals themselves have a tendency to form extremely hard deposits on the wellbore wall and/or different parts of wellbore equipment. Such deposits can thus adhere to the wellbore wall and/or various equipment arranged in a borehole or a pipeline, restricting their use seriously and/or reducing or completely preventing the flow of fluids or gases through the completion string or the pipeline. For example, deposits may prevent opening or closing safety valves or sliding side doors, etc.

[0006] Such deposits are difficult to dissolve by known chemical means or to dislodge by known mechanical

means. For example, chemical treatments, such as, treatments with acids, surface active agents and the like have been utilized in order to clean out scaled wellbore wall or equipment. However, such techniques, while less expensive than a complete workover, are substantially less effective, since they are incapable, in most cases, of dissolving significant amounts of the plugging materials. Another technique, which can be classified as a mechanical technique and has also been suggested for the purpose of cleaning wellbore equipment, includes using brushes, scrapers or pigs. Such technique allows only removing most of the encrusted deposits in areas of the wellbore equipment which are easily accessible. However, brushes, scrapers or pigs are quite inefficient removing encrusted deposits in areas of the wellbore equipment accessible with difficulty or inaccessible. Consequently, it is often necessary to rework the well and replace one or several equipment of the completion string or the pipeline. Such tactics are, of course, both time-consuming and expensive.

[0007] Another method used for removing deposits consists in using an electrical discharge generating device which generates shock waves for creating an electrohydraulic effect. More precisely, in an existing solution, the electrical discharge generating device comprises electrodes in between which a high-voltage current is discharged. The discharge of said high-voltage current generates high-energy shock waves that transmit in the borehole toward a well completion equipment and/or a tubing and/or a casing, the wellbore wall and the subterranean formation.

[0008] When deposits are removed for an equipment or a wellbore wall using these methods, the deposits fall in the wellbore and may block said wellbore or equipment, therefore reducing or preventing the efficiency of oil recovery.

[0009] It is therefore an object of the present invention to provide a device and method for avoiding blocking a wellbore or a wellbore equipment with debris of deposits removed from the wellbore wall and/or a wellbore equipment.

SUMMARY OF THE INVENTION

[0010] To this end, the present invention concerns a collecting device for collecting debris of deposits while said deposits are being removed from a wellbore wall or an equipment arranged in a wellbore of a subterranean formation in order to improve the recovery of formation fluids and/or gases, said collecting device being configured for being attached to a cleaning device, said cleaning device being configured for removing deposits from a wellbore wall or a wellbore equipment arranged in a wellbore, said collecting device comprising:

- a deflector configured for deflecting falling debris of deposits while said deposits are being removed from said wellbore wall or said wellbore equipment, and

- a debris storing module connected to said deflector, said debris storing module being configured for collecting and storing debris deflected by said deflector.

[0011] The collecting device according to the invention allows collecting debris falling by gravity when deposits are removed (i.e. cleaned) from a wellbore wall and/or an equipment arranged in a wellbore. Thus, the collecting device allows thus avoiding debris to fall into the wellbore and block said wellbore and/or some wellbore equipment. The device according to the invention also allows extracting quickly deposits from a wellbore.

[0012] In a preferred embodiment, the deflector comprises a tubular portion comprising a first end connected to the debris storing module and a second end configured for collecting debris, said tubular portion being adapted to convey debris from said second end into the debris storing module through said first end.

[0013] According to an aspect of the invention, the deflector comprises a connecting shaft mounted on the second end of the tubular portion and configured for attaching the collecting device to a cleaning device.

[0014] Preferably, the deflector comprises at least one annular portion extending from the second end of the tubular portion.

[0015] In an embodiment, the at least one annular portion extends radially from the second end of the tubular portion.

[0016] Preferably, the at least one annular portion is flexible or pliable. This allows said at least one annular portion to abut against the surface to be cleaned, for example a casing or the wellbore wall, in order to avoid debris falling between said surface and the deflector into the wellbore.

[0017] In an embodiment, the deflector comprises three annular portions extending from the second end of the tubular portion.

[0018] Advantageously, the debris storing module comprises at least one tubular section configured for storing debris.

[0019] In an embodiment, the debris storing module comprises a plurality of tubular sections connected together along a same longitudinal axis.

[0020] Advantageously, each tubular section comprises a plurality of slots for evacuating liquids and/or gases from the inner part of the debris storing module.

[0021] In an embodiment, the collecting device further comprises an unloading plug connected to the debris storing module and being configured for switching between a first position in which the unloading plug prevents the debris stored in the debris storing module to leave said debris storing module and a second position in which the unloading plug allows the debris stored in the debris storing module to leave said debris storing module.

[0022] According to an aspect of the invention, the unloading plug comprises a trap door allowing the unloading plug to switch (i.e. move) between the first position and the second position (and vice-and-versa).

[0023] Advantageously, the trap door is removable to easily evacuate debris stored in the debris storing module.

[0024] In a preferred embodiment, the unloading plug comprises a tubular portion delimiting an internal opening, the trap door being configured to be moved between a blocking position, in which the trap door obstructs said internal opening, and a free position in which debris stored into the debris storing module may flow through said internal opening to unload the said debris storing module.

[0025] The invention also relates to an assembly for removing deposits from a wellbore wall or an equipment arranged in a wellbore of a subterranean formation and for collecting debris of said deposits, said assembly comprising a cleaning device configured for removing deposits from said wellbore wall or said equipment and a collecting device as previously presented, said collecting device being attached below said cleaning device in order to collect debris from deposits removed by the cleaning device.

[0026] According to an embodiment, the cleaning device and the collecting device extend along a same longitudinal axis in order to ease the use of the assembly in the wellbore, in particular to insert or withdraw the assembly from the wellbore.

[0027] The invention also relates to a method for collecting debris of deposits in a wellbore of a subterranean formation in order to improve the recovery of formation fluids and/or gases, said method comprising the steps of:

- removing deposits from a wellbore wall or an equipment arranged in a wellbore using a cleaning device,
- collecting falling debris of deposits, using a collecting device, as previously presented, attached below said cleaning device, while said deposits are being removed from said wellbore wall or said equipment by the cleaning device.

[0028] Advantageously, the collecting step comprises deflecting the debris so that said debris are received by the second end of the tubular portion of the deflector, conveying the debris from the second end of the deflector to the debris storage module through said tubular portion of the deflector and storing the debris into the debris storage module.

[0029] In an embodiment, the method further comprises a step of unloading the debris stored in the debris storage module.

[0030] In a preferred embodiment, the unloading step comprises opening or removing a trap door to open the unloading plug and unload the collecting device.

BRIEF DESCRIPTION OF THE DRAWINGS

[0031] These and other features, aspects, and advantages of the present invention are better understood with regard to the following Detailed Description of the Pre-

ferred Embodiments, appended Claims, and accompanying Figures, where:

FIGURE 1 schematically illustrates a cross-sectional view of a wellbore comprising a casing in which is arranged an embodiment of an assembly according to the invention;

FIGURE 2 schematically illustrates a side view of an embodiment of a collecting device according to the invention;

FIGURE 3 schematically illustrates a perspective view of the collecting device of FIGURE 2;

FIGURE 4 schematically illustrates another perspective view of the collecting device of FIGURE 2;

FIGURE 5 schematically illustrates a partial exploded view of the collecting device of FIGURE 2;

FIGURE 6 schematically illustrates a perspective view of the deflector of the collecting device of FIGURE 2;

FIGURE 7 schematically illustrates a perspective view of the adapter of the collecting device of FIGURE 2;

FIGURE 8 schematically illustrates a perspective view of a section connector of the collecting device of FIGURE 2;

FIGURE 9 schematically illustrates a perspective view of the unloading plug of the collecting device of FIGURE 2;

FIGURE 10 schematically illustrates a perspective view of the trap door of the unloading plug of the collecting device of FIGURE 2;

FIGURE 11 schematically illustrates a cross-sectional view of the unloading plug of FIGURE 9, the trap door of FIGURE 10 being mounted on said unloading plug;

FIGURE 12 schematically illustrates a collection of debris using the collecting device of FIGURE 2;

FIGURE 13 schematically illustrates an exemplary embodiment of the method according to the invention.

[0032] In the accompanying Figures, similar components or features, or both, may have the same or a similar reference label.

DETAILED DESCRIPTION

[0033] The Specification, which includes the Summary of Invention, Brief Description of the Drawings and the Detailed Description of the Preferred Embodiments, and the appended Claims refer to particular features (including process or method steps) of the invention. Those of skill in the art understand that the invention includes all possible combinations and uses of particular features described in the Specification. Those of skill in the art understand that the invention is not limited to or by the description of embodiments given in the Specification. The inventive subject matter is not restricted except only in

the spirit of the Specification and appended Claims. Those of skill in the art also understand that the terminology used for describing particular embodiments does not limit the scope or breadth of the invention. In interpreting the Specification and appended Claims, all terms should be interpreted in the broadest possible manner consistent with the context of each term. All technical and scientific terms used in the Specification and appended Claims have the same meaning as commonly understood by one of ordinary skill in the art to which this invention belongs unless defined otherwise. As used in the Specification and appended Claims, the singular forms "a", "an", and "the" include plural references unless the context clearly indicates otherwise. The verb "comprises" and its conjugated forms should be interpreted as referring to elements, components or steps in a non-exclusive manner. The referenced elements, components or steps may be present, utilized or combined with other elements, components or steps not expressly referenced. The verb "couple" and its conjugated forms means to complete any type of required junction, including electrical, mechanical or fluid, to form a singular object from two or more previously non-joined objects. If a first device couples to a second device, the connection can occur either directly or through a common connector. "Optionally" and its various forms means that the subsequently described event or circumstance may or may not occur. The description includes instances where the event or circumstance occurs and instances where it does not occur. "Operable" and its various forms means fit for its proper functioning and able to be used for its intended use. Spatial terms describe the relative position of an object or a group of objects relative to another object or group of objects. The spatial relationships apply along vertical and horizontal axes. Orientation and relational words including "uphole" and "downhole"; "above" and "below"; "up" and "down" and other like terms are for descriptive convenience and are not limiting unless otherwise indicated. Where the Specification or the appended Claims provide a range of values, it is understood that the interval encompasses each intervening value between the upper limit and the lower limit as well as the upper limit and the lower limit. The invention encompasses and bounds smaller ranges of the interval subject to any specific exclusion provided. Where the Specification and appended Claims reference a method comprising two or more defined steps, the defined steps can be carried out in any order or simultaneously except where the context excludes that possibility.

[0034] The invention is described hereunder in reference to a well for producing formation fluids or gases such as e.g. oil. This does not limit the scope of the present invention which may be used with any type of formation.

[0035] FIGURE 1 shows a subterranean formation 1 comprising a treatment zone 3. For example, such a treatment zone 3 may be made of rock. The treatment zone 3 may comprise a porous zone that constitutes a reservoir

of hydrocarbons, such as oil or gas. The porous zone is accessible through a wellbore 5 extending from the surface through to the treatment zone 3. The treatment zone 3 interfaces with the wellbore 5 at wellbore wall 5A and extends radially from wellbore 5.

[0036] In the example illustrated on FIGURE 1, a wellbore equipment constituted of a metallic casing 7 is arranged in the wellbore 5. This casing 7 may comprise perforations that allow creating some flow paths within the treatment zone 3 adjacent to the wellbore 5. In another embodiment, the wellbore equipment could be for example a completion string equipment, a production tubing element or any type of equipment arranged in the wellbore 5.

[0037] The wellbore 5 may be partially filled with a liquid, called "wellbore liquid" 6 that reaches a given wellbore liquid 6 level in such a manner that some parts of the casing 7 are arranged above said wellbore liquid level (i.e. in a dry volume of the wellbore 5), whereas some parts of the casing 7 are arranged under the wellbore liquid 6 level. Alternatively, the wellbore 5 could be completely dry (i.e. deprived of liquid).

[0038] As illustrated on FIGURE 1, an electrical discharge generating device 10 is arranged in the wellbore 5. The electrical discharge generating device 10 is configured for generating electrical discharges that propagate shock waves 11 (FIGURE 12), in particular for cleaning the casing 7 in order to improve the recovery of formation fluids and/or gases. In this illustrated example, the electrical discharge generating device 10 constitutes a source of electrohydraulic energy that can be arranged into the wellbore 5 near (i.e. next to) a part of the casing 7 that needs cleaning, in particular to remove deposits 8 stuck on or inside said casing 7 as shown on FIGURE 12.

[0039] The electrical discharge generating device 10 is coupled to a wireline 12 which is operable to raise and lower said electrical discharge generating device 10 and to supply power from the surface to said electrical discharge generating device 10. A voltage source (not shown) located external of the wellbore 5 and an electrical circuit (not shown) mounted within said wireline 12 allow to connect said voltage source to the electrical discharge generating device 10. Electrical power is supplied by the low voltage source at a steady and relatively low power from the surface through the wireline 12 to the downhole electrical discharge generating device 10.

[0040] In this exemplary embodiment, the electrical discharge generating device 10 has a substantially cylindrical shape and may comprises, as already described in US patent 4,345,650 issued to Wesley or US patent 6,227,293 issued to Huffman, incorporated hereby by reference, a power conversion unit, a power storage unit, a control unit and a discharge unit.

[0041] As illustrated on FIGURE 1, an example of collecting device 20 according to the invention is attached to the bottom end 10A of the electrical discharge generating device 10 in order to collect debris 8A of deposits 8 that are removed from the casing 7 by said electrical

discharge generating device 10 as shown on FIGURE 12.

[0042] FIGURES 2 to 5 show an exemplary embodiment of a collecting device 20 according to the invention. The collecting device 20 according to the invention allows collecting debris 8A of deposits 8 while said deposits 8 are being removed from the casing 7 in order to improve the recovery of formation fluids and/or gases.

[0043] In this example, as illustrated on FIGURES 2 to 5, the collecting device 20 is of cylindrical shape having a circular section and comprises a plurality of elements. The collecting device 20 comprises a deflector 210 and a debris storing module 220.

[0044] The deflector 210 is configured for deflecting falling debris 8A of deposits 8 being removed from the casing 7 by the electrical discharge generating device 10.

[0045] In reference to FIGURES 5 and 6, the deflector 210 comprises a tubular portion 212 comprising a first end 212A, adapted to be connected to the debris storing module 220 via an adapter 215, and a second end 212B configured for collecting debris 8A. The tubular portion 212 is adapted to convey debris 8A from said second end 212B through said first end 212A into the debris storing module 220.

[0046] The deflector 210 comprises a connecting shaft 214 extending from the second end 212B of the tubular portion 212 and comprising a free end 214A which is configured for attaching the collecting device 20 to the electrical discharge generating device 10. For example, the free end 214A of the connecting shaft 214 may comprise a hollow central portion which allow inserting a rod (not shown) protruding from the bottom end 10A of the electrical discharge generating device 10.

[0047] As illustrated on FIGURE 6, the second end 212B of the tubular portion 212 comprises an annular flange 212B1 from which extend three wings 213 and in which are formed three openings 213A delimited between said wings 213. The wings 213 allow reinforcing the deflector 210 and guiding debris 8A toward openings 213A into the tubular portion 212.

[0048] In the example illustrated on FIGURE 5, the deflector 210 comprises three annular portion 216 mounted around the annular flange 212B1 and the second end 212B of the tubular portion 212. The annular portion 216 aims the debris 8A removed from the casing 7 into the inner flow path of openings 213A of the deflector 210. The annular portions 216 are made with a pliable or flexible material such that contact is maintained between the deflector 210 and the wellbore wall 5A or casing 7 (or deposits 8 - see figure 12) so that all material is directed into the openings 213A and collected by the collecting device 20.

[0049] As illustrated on FIGURES 2 to 5, the debris storing module 220 comprises three tubular sections, namely a first tubular section 220A, a second tubular section 220B and a third tubular section 220C connected together along a same longitudinal axis X (FIGURES 2 and 5). In another embodiment, the debris storing module 220 could comprise more or less than three tubular sec-

tions. As illustrated on FIGURE 5, each of the first tubular section 220A, the second tubular section 220B and the third tubular section 220C comprises a plurality of slots 2200 which allow liquids that enter into the debris storing module 220 via the deflector 210 to be evacuated. More precisely, the dimensions of the slots 2200 are adapted to allow liquids that enter into the debris storing module 220 via the deflector 210 to be evacuated while debris 8A stored inside the first tubular section 220A, second tubular section 220B and/or third tubular section 220C remain inside the debris storing module 220.

[0050] The debris storing module 220 is configured to be connected to the deflector 210 for storing debris 8A deflected by said deflector 210. To this end, the collecting device 20 comprises an adapter 215, shown on FIGURE 7, which allows connecting the first end 212A of the tubular portion 212 of the deflector 210 to an end 220A1 of the first tubular section 220A as shown on FIGURE 5. In this example, the adapter 215 comprises a first end 215A of tubular shape, adapted to receive the first end 212A of the tubular portion 212 of the deflector 210, for example by clipping or press-fitting, and a second end 215B, also of tubular shape but of a smaller diameter, and which is adapted to be inserted into the corresponding end 220A1 of the first tubular section 220A. In order to fix the end 220A1 of the first tubular section 220A to the second end 215B of the adapter 215, the adapter 215 comprises a plurality of pins 215C (FIGURE 7) which are configured to fit into corresponding plurality of holes (not visible) forms onto the end 220A1 of the first tubular section 220A. The adapter 215 also comprise two grooved portions 215D formed on opposite parts of the side wall of the adapter 215 for carrying the collecting device 20 with a lifting tool such as e.g. a crane or a forklift.

[0051] As shown on FIGURE 5, the collecting device 20 also comprises a first section connector 221-1 and a second section connector 221-2. The first section connector 221-1 allows connecting the first tubular section 220A and the second tubular section 220B. The second section connector 221-2 allows connecting the second tubular section 220B and the third tubular section 220C.

[0052] As illustrated on FIGURE 8, a section connector 221, such as the first section connector 221-1 and the second section connector 221-2, has a tubular shape and comprises two ends 221A, 221B adapted to be inserted into a corresponding end of the first tubular section 220A, the second tubular section 220B and the third tubular section 220C. The section connector 221 is fixed to the first tubular section 220A, second tubular section 220B and third tubular section 220C by clipping using pins 221C protruding from ends 221A, 221B of said section connector 221.

[0053] In this preferred embodiment, the collecting device 20 further comprises an unloading plug 230 that allows evacuating easily the debris 8A stored in the debris storage module 220, in particular when the debris storage module 220 is full and/or when the collecting device 20 is pulled out of the wellbore 5.

[0054] To this end, the unloading plug 230 is connected to the debris storing module 220 and is configured to be placed in a first configuration, in which the unloading plug 230 prevents the debris 8A stored in the debris storing module 220 to leave said debris storing module 220, and a second configuration, in which the unloading plug 230 allows the debris 8A stored in the debris storing module 220 to leave said debris storing module 220.

[0055] In reference to FIGURES 9 to 11, the unloading plug 230 comprises a connecting end 231A, a tubular portion 231 delimiting an internal opening 232, a free end 231B and a trap door 235. In the example illustrated on FIGURE 9, the connecting end 231A comprises pins 233 protruding from said connecting end 231A, which are configured to engage with holes formed in the end 220C1 of the third tubular section 220C in order to fix the unloading plug 230 on the third tubular section 220C by clipping. As shown on FIGURE 11, the tubular portion 231 comprises a slot 234 formed in the side wall of said tubular portion 231, which is configured for receiving the trap door 235.

[0056] The trap door 235, illustrated on FIGURE 10, may be mounted in a removable manner in the slot 234 of the tubular portion 231. In this exemplary embodiment, the trap door 235 is a one-piece element comprising a plate portion 235A and a connection portion 235B extending perpendicularly from said plate portion 235A and which is configured for receiving a screw 236 (FIGURE 11) allowing fixing the trap door 235 on the tubular portion 231.

[0057] Thus, when the trap door 235 is mounted in the slot 234 of the tubular portion 231, in a position called blocking position, the trap door 235 obstruct entirely the internal opening 232 of the tubular portion 231 to prevent the debris 8A from leaving the debris storing module 220 (first configuration of the unloading plug 230).

[0058] When the trap door 235 is removed from the slot 234 of the tubular portion 231 (called free position), the internal opening 232 of the tubular portion 231 allows debris 8A to leave the debris storing module 220 to empty said debris storing module 220 from debris 8A (second configuration of the unloading plug 230).

[0059] An exemplary embodiment of the method according to the invention will now be described in reference to FIGURE 13.

[0060] In a step S1, the connecting shaft 214 of the collecting device 20 is first attached to the bottom end 10A of the electrical discharge generating device 10, extending along the same longitudinal axis X, to form an assembly 300 which is then lowered inside the casing 7 down the wellbore 5 using the wireline 12.

[0061] When the electrical discharge generating device 10 is arranged near a portion of the casing 7 which needs to be cleaned from deposits 8, the electrical discharge generating device 10 is activated to generate electrical discharges that propagate shock waves 11 to remove deposits 8 from the casing 7 internal wall in a step S2.

[0062] When debris 8A of deposits 8 being removed fall under the effect of gravity, the deflector 210, and in particular the annular portions 216, deflect said debris 8A, in a step S3, toward the openings 213A so that said debris 8A go through the tubular portion 212 up to debris storing module 220 where the debris 8A are stored in a step S4.

[0063] The assembly 300 formed of the electrical discharge generating device 10 and the collecting device 20 may then be moved toward another portion of the casing 7 that needs to be cleaned from deposits 8.

[0064] When the debris storing module 220 is full or when the casing 7 is clean from deposits 8 or when the debris storing module 220 is full, the assembly 300 may be pulled out of the wellbore 5 and the trap door 235 may be open, by removing screw 236, to unload debris 8A stored in the debris storing module 220 in a step S5.

[0065] In the exemplary embodiment described here above, the cleaning device is an electrical discharge generating device. However, in another embodiment, the cleaning device could be any type of device adapted to remove the deposits for a wellbore wall 5A or an equipment arranged in a wellbore 5.

[0066] The device and method according to the invention allow therefore efficiently, rapidly and easily collect deposits that are removed from a wellbore wall and/or a wellbore equipment.

Table of references

1	subterranean formation
3	treatment zone
5	wellbore
6	wellbore liquid 6
7	casing
8	deposits
8A	debris
10	electrical discharge generating device
10A	bottom end
11	shock wave
12	wireline
20	collecting device
210	deflector
212	tubular portion
212A	first end
212B	second end
212B1	annular flange
213	wings
213A	openings
214	connecting shaft

(continued)

214A	free end
215	adapter
215A	first end
215B	second end
215C	pin
215D	grooved portion
216	annular portion
220	debris storing module
2200	slot
220A	first tubular section
220A1	end
220B	second tubular section
220C	third tubular section
220C1	end
221	section connector
221A	end
221B	end
221-1	first section connector
221-2	second section connector
221C	pin
230	unloading plug
231	tubular portion
231A	connecting end
231B	free end
232	internal opening
233	pin
234	slot
235	trapdoor
235A	plate portion
235B	connection portion
236	screw
300	assembly

Claims

1. A collecting device (20) for collecting debris (8A) of deposits (8) while said deposits (8) are being removed from a wellbore wall (5A) or an equipment (7) arranged in a wellbore (5) of a subterranean formation (1) in order to improve the recovery of formation fluids and/or gases, said collecting device (20) being

configured for being attached to a cleaning device (10), said cleaning device (10) being configured for removing deposits (8) from a wellbore wall (5A) or a wellbore equipment (7) arranged in a wellbore (5), said collecting device (20) comprising:

- a deflector (210) configured for deflecting falling debris (8A) of deposits (8) while said deposits (8) are being removed from said wellbore wall (5A) or said wellbore equipment (7), and
 - a debris storing module (220) connected to said deflector (210), said debris storing module (220) being configured for collecting and storing debris (8A) deflected by said deflector (210).
2. A collecting device (20) according to claim 1, wherein the deflector (210) comprises a tubular portion (212) comprising a first end (212A) connected to the debris storing module (220) and a second end (212B) configured for collecting debris (8A), said tubular portion (212) being adapted to convey debris (8A) from said second end (212B) into the debris storing module (220) through said first end (212A).
 3. A collecting device (20) according to claim 2, wherein the deflector (210) comprises a connecting shaft (214) mounted on the second end (212B) of the tubular portion (212) and configured for attaching the collecting device (20) to a cleaning device (10).
 4. A collecting device (20) according to any of claims 2 to 3, wherein the deflector (210) comprises at least one annular portion (216) extending from the second end (212B) of the tubular portion (212).
 5. A collecting device (20) according to any of the preceding claims, wherein the debris storing module (220) comprises at least one tubular section (220A, 220B, 220C) configured for storing debris (8A).
 6. A collecting device (20) according to claim 5, wherein the debris storing module (220) comprises a plurality of tubular sections (220A, 220B, 220C) connected together along a same longitudinal axis (X).
 7. A collecting device according to any of claim 5 or 6, wherein each tubular section (220A, 220B, 220C) comprises a plurality of slots (2200).
 8. A collecting device (20) according to any of the preceding claims, said collecting device (20) further comprising an unloading plug (230) connected to the debris storing module (220) and being configured for switching between a first position in which the unloading plug (230) prevents the debris (8A) stored in the debris storing module (220) to leave said debris storing module (220) and a second position in which the unloading plug (230) allows the debris (8A)

stored in the debris storing module (220) to leave said debris storing module (220).

9. A collecting device (20) according to claim 8, wherein the unloading plug (230) comprises a trap door (235) allowing the unloading plug (230) to switch between the first position and the second position.
10. A collecting device (20) according to claim 9, wherein the trap door (235) is removable.
11. A collecting device (20) according to any of claims 8 and 9, wherein the unloading plug (230) comprises a tubular portion (231) delimiting an internal opening (236).
12. A collecting device (20) according to claim 11, wherein the trap door (235) is configured to be moved between a blocking position, in which the trap door (235) obstructs said internal opening (236), and a free position in which debris (8A) stored into the debris storing module (220) may flow through said internal opening (236) to unload the said debris storing module (220).
13. An assembly (300) for removing deposits (8) from a wellbore wall (5A) or an equipment (7) arranged in a wellbore (5) of a subterranean formation (1) and for collecting debris (8A) of said deposits (8), said assembly (300) comprising a cleaning device (10) configured for removing deposits (8) from said wellbore wall (5A) or said equipment (7) and a collecting device (20) according to any of the preceding claims, said collecting device (20) being attached below said cleaning device (10) in order to collect debris (8A) from deposits (8) removed by the cleaning device (10).
14. The assembly (300) according to claim 13, wherein the cleaning device (10) and the collecting device (20) extend along a same longitudinal axis (X).
15. A method for collecting debris (8A) of deposits (8) in a wellbore (5) of a subterranean formation (1) in order to improve the recovery of formation fluids and/or gases, said method comprising the steps of:
 - removing (S2) deposits (8) from a wellbore wall (5A) or an equipment (7) arranged in a wellbore (5) using a cleaning device (10),
 - collecting (S3, S4) falling debris (8A) of deposits (8), using a collecting device (20), according to any of claims 1 to 12, attached below said cleaning device (10), while said deposits (8) are being removed from said wellbore wall (5A) or said equipment (7) by the cleaning device (10).

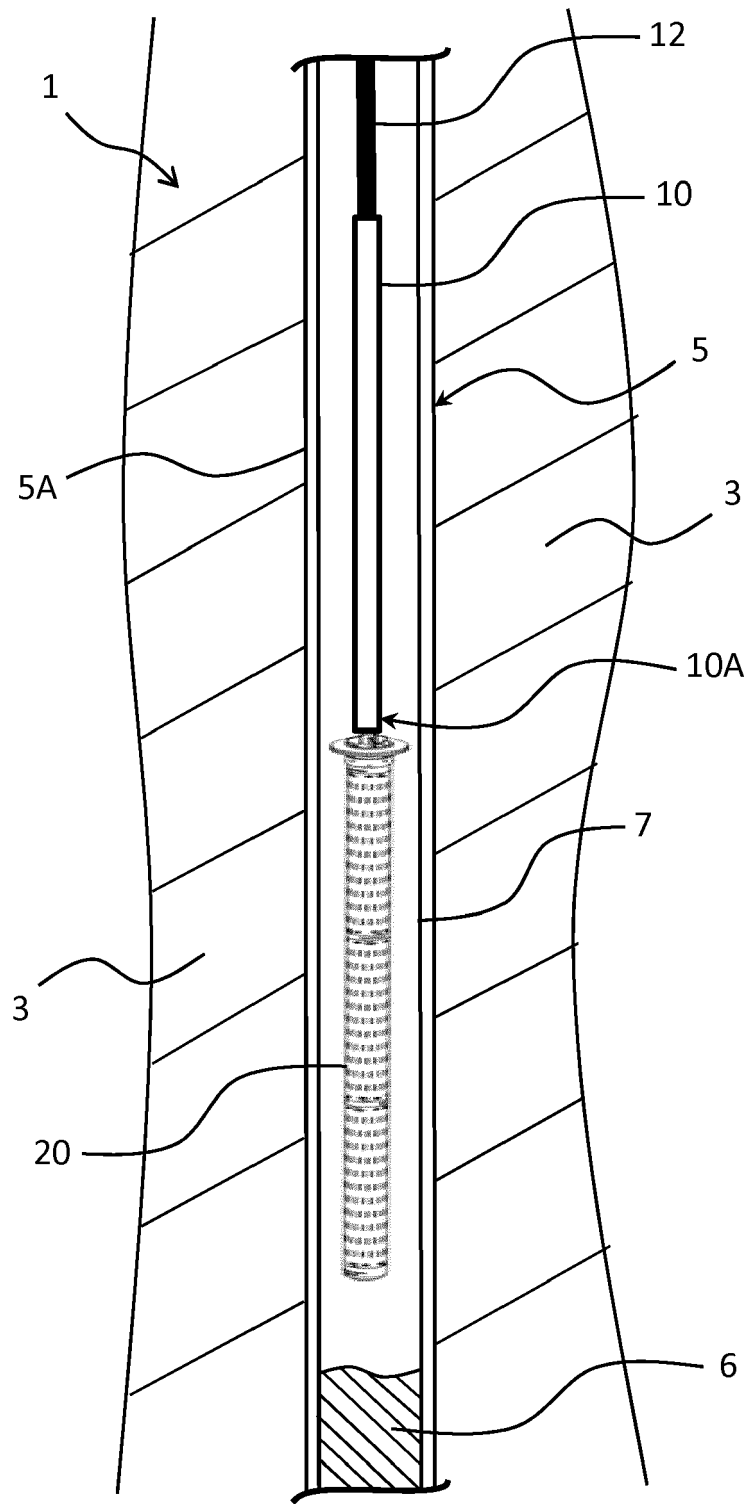

FIGURE 1

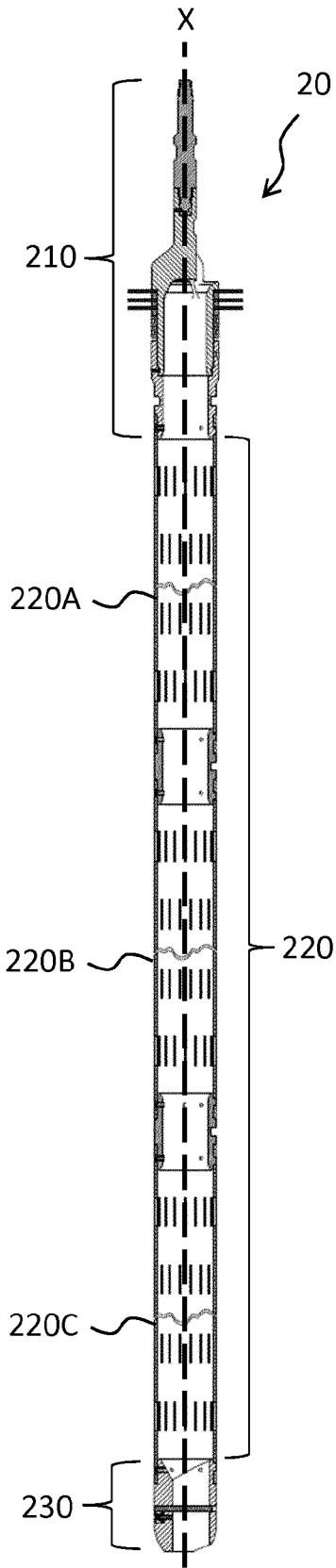

FIGURE 2

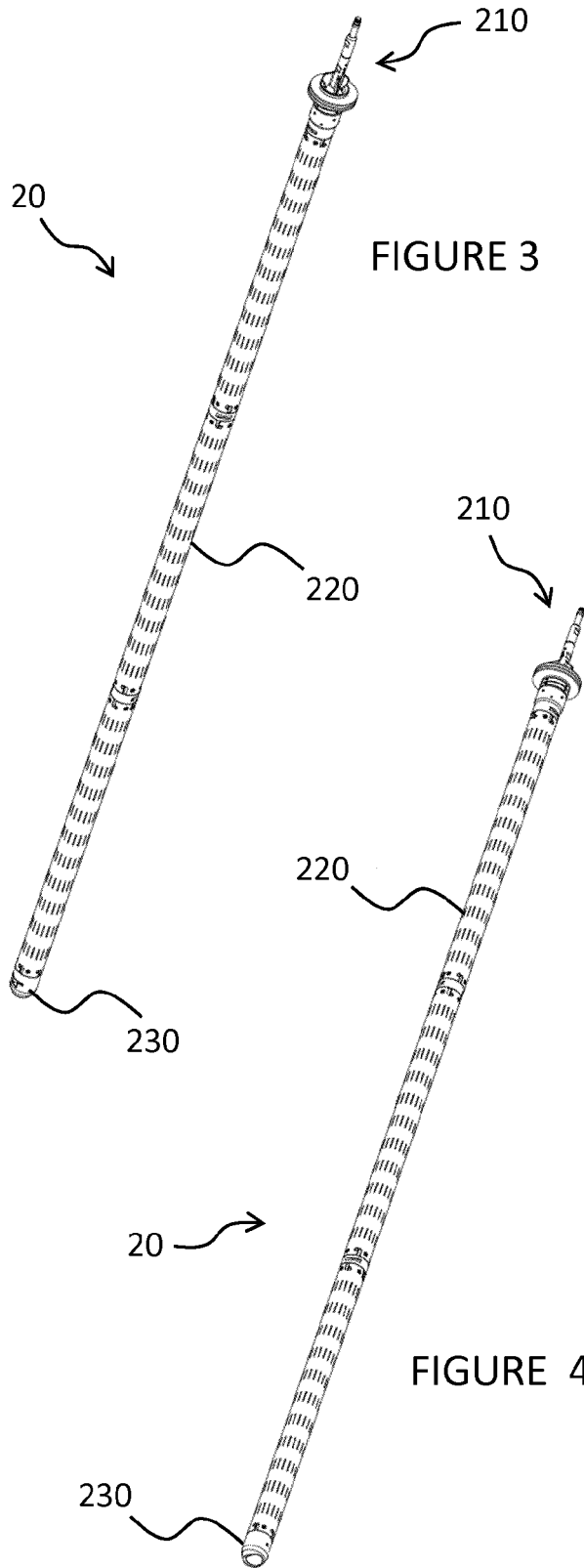

FIGURE 3

FIGURE 4

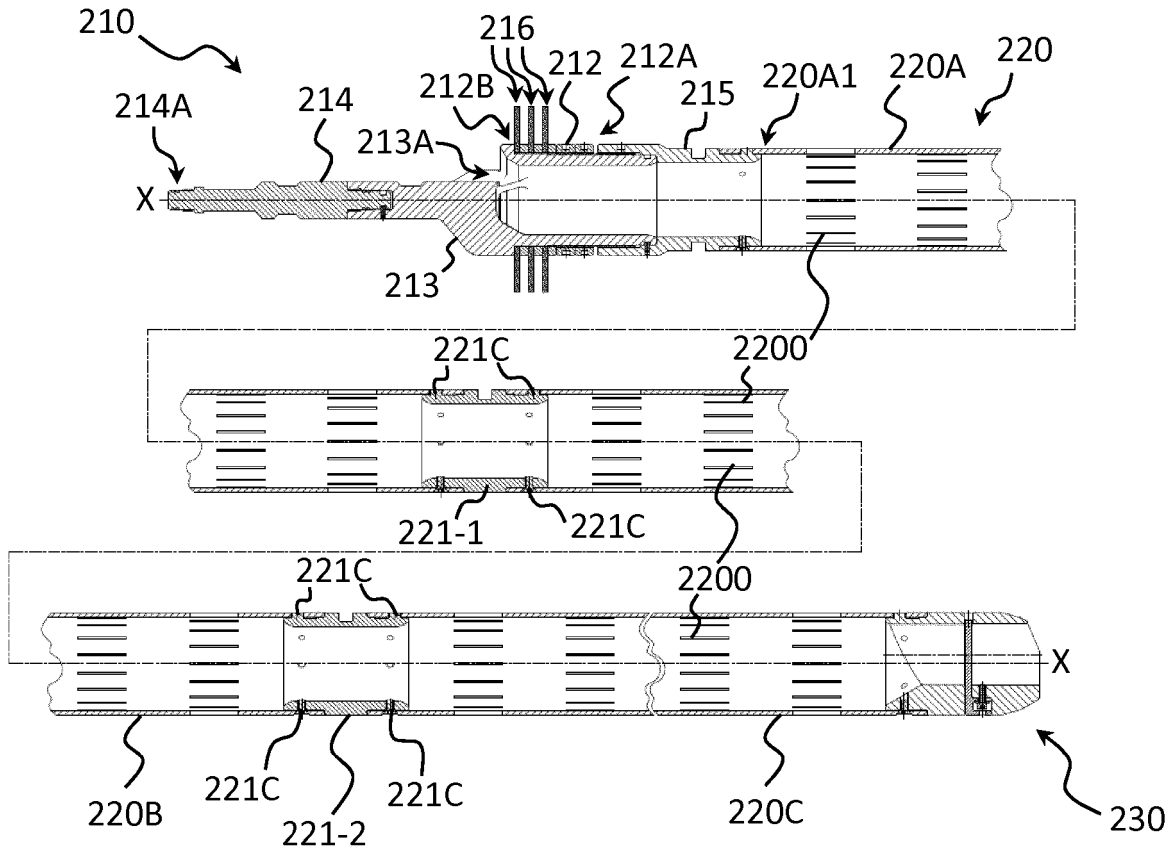

FIGURE 5

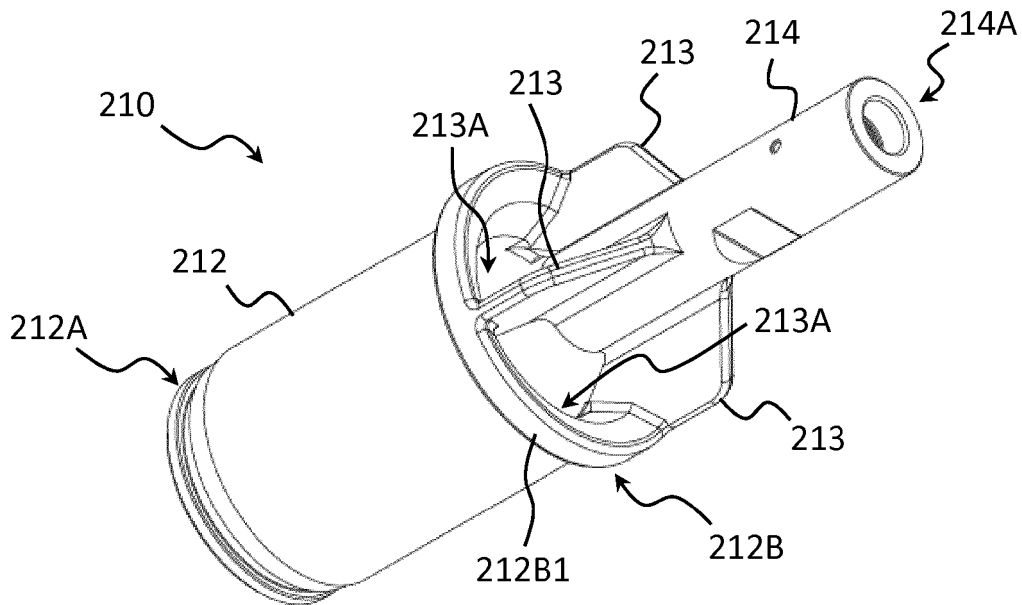

FIGURE 6

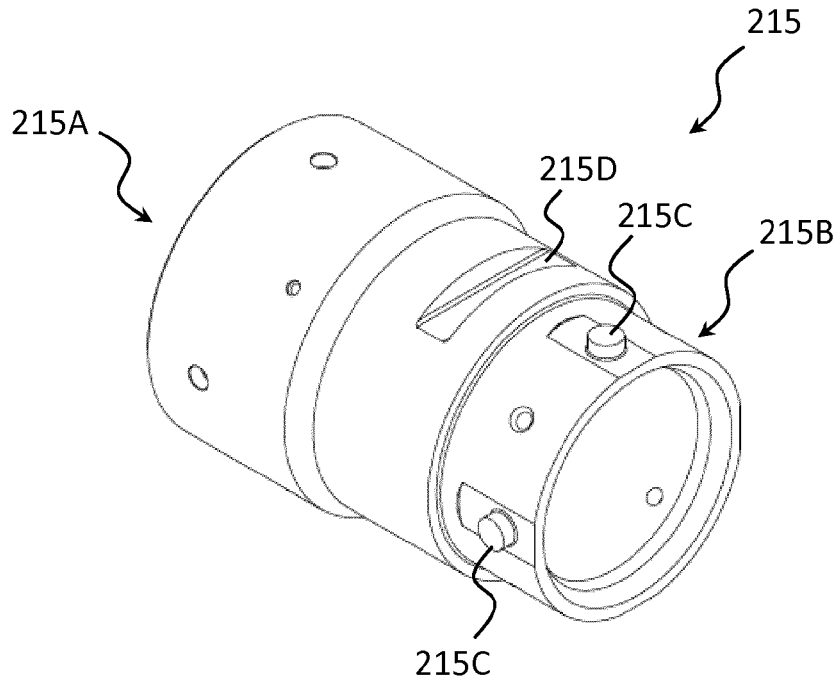

FIGURE 7

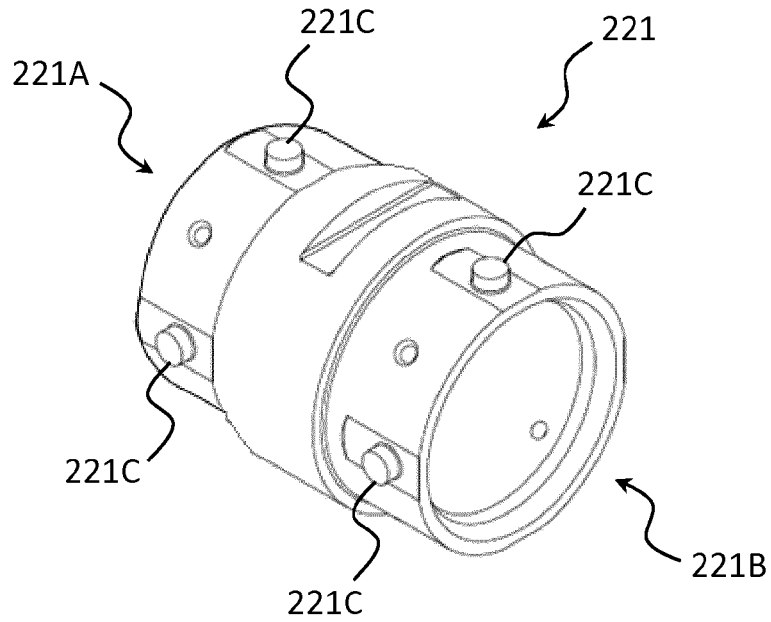
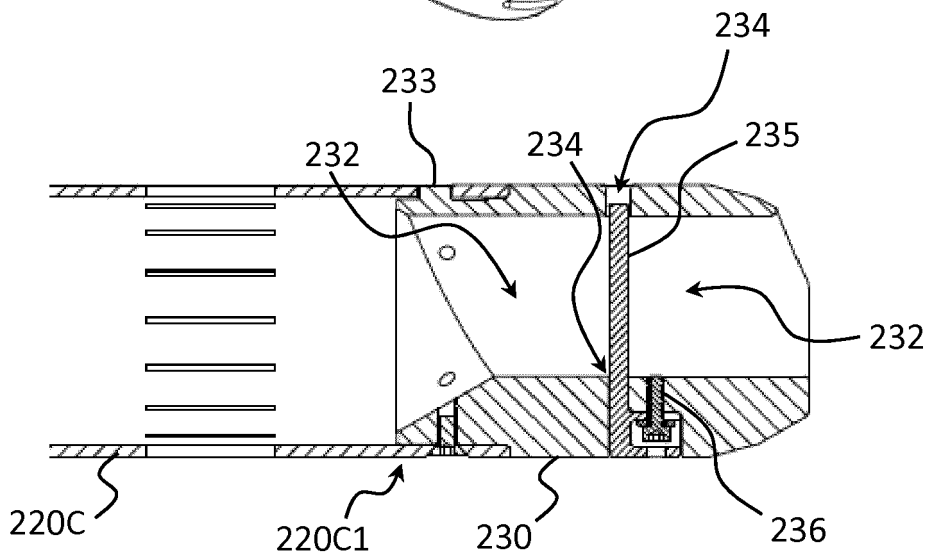
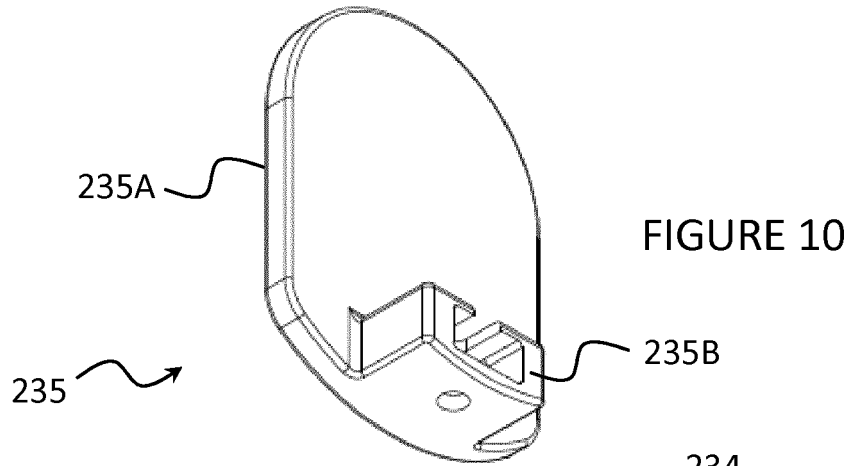
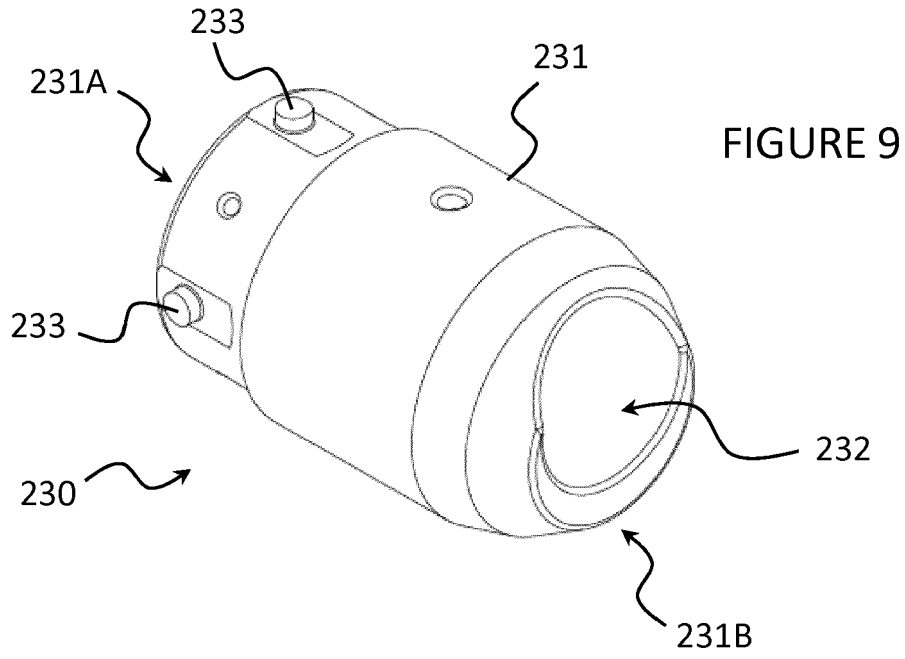

FIGURE 8



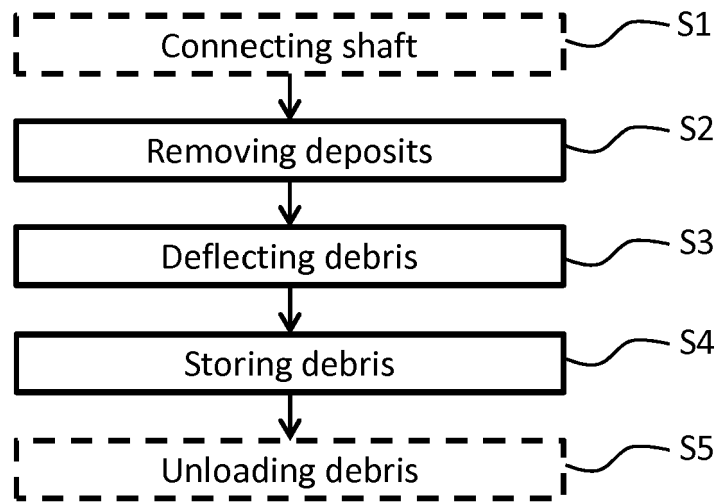

FIGURE 13



EUROPEAN SEARCH REPORT

Application Number
EP 18 16 4037

5

10

15

20

25

30

35

40

45

50

55

DOCUMENTS CONSIDERED TO BE RELEVANT			
Category	Citation of document with indication, where appropriate, of relevant passages	Relevant to claim	CLASSIFICATION OF THE APPLICATION (IPC)
X	WO 2015/023785 A1 (ABRADO INC [US]) 19 February 2015 (2015-02-19) * figures 1-3 * * page 1, lines 10-19 * * page 5, lines 17-24 * * page 6, lines 1-13 * * page 9, lines 11-33 * * page 10, lines 1-26 * * page 11, lines 13-20 * -----	1-15	INV. E21B27/00 E21B37/00
X	US 2018/016860 A1 (STANGELAND JAN [NO]) 18 January 2018 (2018-01-18) * paragraphs [0001] - [0007], [0040] - [0041], [0044], [0048] * * figures 1-2,4,7,8-9 * -----	1-15	
X	US 7 513 303 B2 (BAKER HUGHES INC [US]) 7 April 2009 (2009-04-07) * figures 1-2 * * column 1, lines 1-8 * * column 2, line 30 - column 3, line 15 * -----	1-15	TECHNICAL FIELDS SEARCHED (IPC)
A	EP 2 940 244 A1 (BLUE SPARK ENERGY INC [CA]) 4 November 2015 (2015-11-04) * The whole document and in particular par.1 and 32 and fig.1-6 * -----	1-15	B08B E21B
The present search report has been drawn up for all claims			
Place of search The Hague		Date of completion of the search 14 September 2018	Examiner Pasquini, Matteo
CATEGORY OF CITED DOCUMENTS X : particularly relevant if taken alone Y : particularly relevant if combined with another document of the same category A : technological background O : non-written disclosure P : intermediate document		T : theory or principle underlying the invention E : earlier patent document, but published on, or after the filing date D : document cited in the application L : document cited for other reasons & : member of the same patent family, corresponding document	

3
EPO FORM 1503 03.82 (P04C01)

ANNEX TO THE EUROPEAN SEARCH REPORT
ON EUROPEAN PATENT APPLICATION NO.

EP 18 16 4037

5

This annex lists the patent family members relating to the patent documents cited in the above-mentioned European search report. The members are as contained in the European Patent Office EDP file on
The European Patent Office is in no way liable for these particulars which are merely given for the purpose of information.

14-09-2018

10

Patent document cited in search report	Publication date	Patent family member(s)	Publication date
WO 2015023785 A1	19-02-2015	GB 2534493 A	27-07-2016
		US 2016168939 A1	16-06-2016
		WO 2015023785 A1	19-02-2015

US 2018016860 A1	18-01-2018	BR 112017021082 A2	03-07-2018
		CA 2980242 A1	06-10-2016
		EP 3277917 A1	07-02-2018
		NO 338348 B1	08-08-2016
		US 2018016860 A1	18-01-2018
		WO 2016155852 A1	06-10-2016

US 7513303 B2	07-04-2009	NONE	

EP 2940244 A1	04-11-2015	NONE	

15

20

25

30

35

40

45

50

55

EPO FORM P0459

For more details about this annex : see Official Journal of the European Patent Office, No. 12/82

REFERENCES CITED IN THE DESCRIPTION

This list of references cited by the applicant is for the reader's convenience only. It does not form part of the European patent document. Even though great care has been taken in compiling the references, errors or omissions cannot be excluded and the EPO disclaims all liability in this regard.

Patent documents cited in the description

- US 4345650 A, Wesley [0040]
- US 6227293 B, Huffman [0040]