



(12) **EUROPEAN PATENT APPLICATION**

(43) Date of publication:  
**09.10.2019 Bulletin 2019/41**

(51) Int Cl.:  
**A63H 33/04 (2006.01)** **A63H 33/08 (2006.01)**  
**A63H 33/22 (2006.01)**

(21) Application number: **18165749.5**

(22) Date of filing: **04.04.2018**

(84) Designated Contracting States:  
**AL AT BE BG CH CY CZ DE DK EE ES FI FR GB GR HR HU IE IS IT LI LT LU LV MC MK MT NL NO PL PT RO RS SE SI SK SM TR**  
 Designated Extension States:  
**BA ME**  
 Designated Validation States:  
**KH MA MD TN**

(72) Inventors:  
 • **Lauritsen, Martin Pryds**  
**6000 Kolding (DK)**  
 • **Christiansen, Nick Joen Peter Koberg Højgaard**  
**6621 Gesten (DK)**

(74) Representative: **Rottenberg, Annabell Simone**  
**Tropa ApS**  
**Agade 97, 1st Floor**  
**8370 Hadsten (DK)**

(71) Applicant: **Beady System ApS**  
**6000 Kolding (DK)**

(54) **SYSTEM AND METHOD FOR ASSISTED CONSTRUCTION**

(57) A system (20) and a method for assisting a user to build a construction (e.g. an image) (48) on a bead plate (2) comprising a plurality of pins (6, 6', 6'') protruding from a base portion (8) and being configured to receive a bead (4, 4', 4''). The system comprises an illumination device (10) configured to illuminate the pins (6, 6', 6'')

and hereby provide a number of illumination areas (12, 12''). The illumination device (10) comprises a control unit (64) configured to be applied to select a subset of the pins (6, 6', 6'') to be illuminated by the illumination device (10).

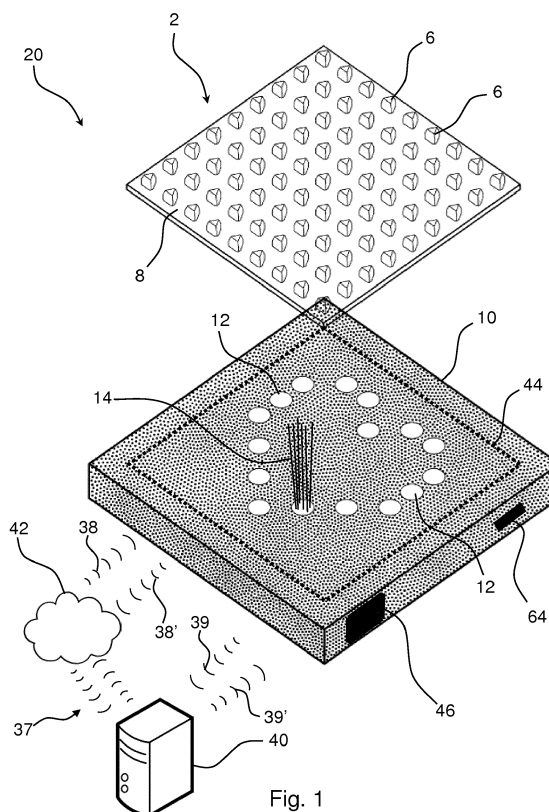

Fig. 1

**Description****Field of invention**

5 **[0001]** The present invention relates to a system and a method for assisted construction by using a body structure such as a bead plate. The present invention also relates to a system comprising an improved body structure (e.g. a bead plate).

**Prior art**

10 **[0002]** Plate constructions is very popular among children. For decades children have been building images (constructions) on body structures such as bead plates (also known as pegboards) comprising a plurality of pins each protruding from a base portion. The pins are configured and arranged to receive a bead, however, positioning of the beads in the correct positions can be challenging for children.

15 **[0003]** Therefore, systems have been developed to assisting uses (typically children) to build an image on a bead plate comprising a plurality of pins each protruding from a base portion. It is, by way of example, known to apply digital systems for the purpose of assisting a user to build an image on a bead plate. This is done by fixing the bead plate to a tablet or another illumination device. When the bead plate has been fixed, the bead plate can be illuminated for the purpose of assisting the user to build an image on a bead plate.

20 **[0004]** It is, however, difficult to distinguish between colours that only differ slightly when using the prior art assisting systems. Therefore, the images typically apply colours that are easy to distinguish from each other.

**[0005]** Thus, there is a need for a system and a method which enables a more user-friendly assistance, and which reduces or even eliminates the above-mentioned disadvantages of the prior art.

25 **[0006]** It is an object to provide a system that makes it possible to ease the construction process and makes it possible to build an image that requires building elements (e.g. beads, building structures or building bricks) of colours that only slightly differs from each.

**Summary of the invention**

30 **[0007]** The object of the present invention can be achieved by a system as defined in claim 1 and by a method as defined in claim 12. Preferred embodiments are defined in the dependent subclaims, explained in the following description and illustrated in the accompanying drawings.

35 **[0008]** The system according to the invention is a system for assisting a user to build a construction on a body structure comprising a plurality of coupling structures arranged on a base portion and being configured to receive a building element, wherein the system comprises:

- an illuminator configured to provide illumination of at least a portion of the body structure and hereby provide a number of illumination areas, wherein the system comprises a control unit configured to be applied to select a subset of the coupling structures and initiate an illumination that enables a unique identification of the selected subset of the coupling structures to be established by means of the illumination. Hereby, it is possible to ease the construction process. Furthermore, it is possible to build an image that requires building elements (e.g. beads or building blocks) of colours and/or geometry and/or size that only slightly differs from each other

45 **[0009]** The system is configured to assist a user during the construction process when an image/construction is made by using a body structure (e.g. a bead plate) comprising a plurality of coupling structures (e.g. pins or grooves) each arranged on a base portion and being configured to receive a building element. In one embodiment, the body structure is a bead plate comprising a plurality of pins protruding from a base portion and being configured to receive a bead. In another embodiment, the body structure is a plate or other body comprising a plurality of pins protruding from a base portion and being configured to receive building blocks.

50 **[0010]** The system comprises:

- an illuminator configured to provide illumination of at least a portion of the body structure and hereby provide a number of illumination areas, wherein the system comprises a control unit configured to be applied to select a subset of the coupling structures and initiate an illumination that enables a unique identification of the selected subset of the coupling structures to be established by means of the illumination. The illuminator may be an illumination device configured to provide illumination of at least a portion of the body structure. Alternatively, the illuminator may be a unit configured to apply externally provided light (e.g. to use a reflective display/screen)

**[0011]** The illuminator may be an illumination device configured to illuminate and/or change the degree of illumination of the coupling structures (e.g. pins or grooves) and hereby provide a number of illumination areas. The illuminator may be an illumination device may be a tablet, a smartphone, a computer or a dedicated electric device comprising a display unit configured to provide activated illumination areas in order to indicate the colour of the bead(s) to be arranged in predefine position(s) indicated on a body structure (e.g. a bead plate).

**[0012]** By the term "illuminate" is meant: illuminate and/or change the degree of illumination.

**[0013]** The body structure may be any structure that comprises a plurality of coupling structures suitable of receiving a building element. The body structure may be a bead plate, a building brick plate or a plate provided with grooves for receiving objects. The coupling structures may be male structures provided as pins or female structure formed as receiving grooves.

**[0014]** It may be an advantage that the illumination device comprises a display unit configured to brought into contact with the backside of a body structure (e.g. a bead plate). The illumination device may comprise fixing structures configured to detachably attach the body structure to the illumination device.

**[0015]** The illumination device comprises a control unit configured to be applied to select a subset of the coupling structures to be illuminated by the illumination device. This may be controlled by using a computer implemented program running on the control unit or a processing unit being controlled by the control unit.

**[0016]** In a preferred embodiment, the system is configured to automatically shift illumination of coupling structure (from one colour or subset of colours) when the process of arranging the building elements on or in the predefined coupling structure is accomplished. The accomplishment may be carried out by the user by using a user interface of the system.

**[0017]** The selection of a subset of the coupling structures to be illuminated by the illumination device may be controlled externally e.g. by using an application running on an external server, wherein the illumination device is connected to the external server.

**[0018]** The base portion may have any suitable shape. In one embodiment, the base portion is rectangular. In one embodiment, the base portion is square. In one embodiment, the base portion is triangular.

**[0019]** In one embodiment, the control unit is integrated in the illumination device.

**[0020]** In a preferred embodiment the system comprises an illumination device configured to illuminate the coupling structures (e.g. pins or grooves) and hereby provide a number of illumination areas, wherein the illumination device comprises a control unit configured to be applied to select a subset of the coupling structures (e.g. pins or grooves) to be illuminated by the illumination device.

**[0021]** It may be an advantage that the illuminator is configured to provide illumination of at least a portion of the body structure from below.

**[0022]** It may be an advantage that the control unit is configured to select the subset of the coupling structures (e.g. pins) to be illuminated by the illumination device in such a manner that the illumination device provides illumination areas of a first selection of colours not constituting all colours of the image.

**[0023]** Hereby, it is possible provide a more user-friendly system that makes it possible to build an image that requires building elements of colours and/or geometry and/or size that only slightly differs from each.

**[0024]** It may be beneficial that the control unit is configured to select the subset of the coupling structures (e.g. pins or grooves) to be illuminated and/or not to be illuminated and/or in which the degree of illumination has to be changed by the illumination device in such a manner that the illumination device provides illumination areas of a single colour. This enables that colours that are nearly identical can be used in an image and that the construction can be made by using the system.

**[0025]** It may be advantageous that the control unit is configured to receive feedback from the user, when the user has finished inserting building elements of a predefined group of colours or a single predefined colour, wherein the control unit is configured to hereafter illuminate and/or change the degree of illumination of the coupling structures that has not been illuminated.

**[0026]** Hereby, it is possible to let the user interact hereby reducing the time between consecutive illumination steps (illumination of consecutive colours or consecutive subgroups of colours).

**[0027]** It may be an advantage that the system comprises a body structure (e.g. a bead plate or a building block plate or a plate having grooves) having a plurality of segments configured to be detachably attached to each other.

**[0028]** It may be an advantage that the body structure is having a plurality of segments configured to be detachably attached to each other.

**[0029]** Hereby, it is possible to join segments to form a larger body structure (e.g. a bead plate).

**[0030]** It may be advantageous that the segments each comprises a plurality of attachment structures extending in extension of the base portion of the segment. Hereby, it is possible to provide a reliable attachment of adjacent segments in an easy manner.

**[0031]** It may be beneficial that the attachment structures of the segments are positioned in side by side manner, in which a space is provided between adjacent attachment structures. Such construction may ease the joining process.

**[0032]** It may be an advantage that each attachment structure comprises a side structure and that an angled portion is provided at each side structure of each of the attachment structures. Hereby, the joining process (attaching adjacent segments to each other) is eased.

**[0033]** It may be beneficial that every second attachment structure is arranged in a higher level than the remaining attachment structures of a segment. Hereby, the attachment structure positioned in a high level of a segment is configured to be engagingly attached to the corresponding attachment structure positioned in a low level of the adjacent segment.

**[0034]** It may be advantageous that each of the attachment structures comprise an engagement portion configured to engage with a corresponding engagement portion of an attachment structure of an adjacent being attached by means of the attachment structures. Hereby, the engagement portion of the attachment structure of a segment will engage with the engagement portion of the attachment structure of an adjacent segment.

**[0035]** It may be an advantage that each of the attachment structures comprise a flat portion provided next to the engagement portion. It may be preferred that the engagement portion protrudes from the bead plate (along the normal axis of the bead plate). Hereby, a better grip can be provided between engaging engagement portions.

**[0036]** It may be beneficial that each segment is quadrangular, preferably rectangular (e.g. square) and that four attachment structures are provided on each side of each segment.

**[0037]** It may be an advantage that the length of adjacent attachment structures differs.

**[0038]** It may be advantageous that the attachment structures are grouped into two groups of equal length, wherein the length of the shortest attachment structures is smaller than the length of the long attachment structures.

**[0039]** Hereby, it is, as shown in Fig. 6A and Fig. 6B as well as Fig. 7A and Fig. 7B, possible to slide a segment into engagement with segments already being attached to each other.

**[0040]** It may be an advantage that the body structure is a bead plate that comprises pins provided with edge portions configured to provide a radially directed force towards (the inside portion of) a bead when the bead is being attached to the pin. This can be done whenever the diameter of the pin is larger than the diameter of the hole in the bead.

**[0041]** It may be advantageous that the pins comprise a base portion, wherein the edge portions extend in extension of the base portion.

**[0042]** The base portion may have a basically triangular cross section, a basically rectangular cross section.

**[0043]** It may be an advantage that the body structure (e.g. a bead plate) is provided with a positioning unit configured to keep the body structure in a fixed position and orientation relative to the illumination device.

**[0044]** It may be advantageous that the positioning unit is provided as an anti-slip structure provided at the bottom end of the body structure (e.g. a bead plate or a building brick plate).

**[0045]** It may be beneficial that the positioning unit is a mat being attached to the body structure (e.g. a bead plate) or being configured to be attached to the body structure, wherein the mat is configured to provide a friction large enough to maintain the mat and thus the body structure in a fixed position and orientation relative to the illumination device.

**[0046]** It may be advantageous that the positioning unit is a coating being attached to the body structure (e.g. a bead plate or a building brick plate) and being configured to provide a friction large enough to maintain the coating and thus the body structure in a fixed position and orientation relative to the illumination device.

**[0047]** It may be beneficial that a plurality of holes is provided in the positioning unit, wherein the holes are arranged in such a manner that light from the illumination device can illuminate the coupling structures (e.g. pins or grooves) through the holes.

**[0048]** The method according to the invention is a method for assisting a user to build a construction on a body structure comprising a plurality of coupling structures arranged on a base portion (8) and being configured to receive a building element, wherein the method comprises the step of applying an illuminator to illuminate at least a portion of the body structure and/or change the degree of illumination of at least a portion of the body structure and hereby provide a number of illumination areas, wherein the method comprises the following step:

- selecting a subset of the coupling structures;
- illuminating at least a portion of the body structure and hereby enabling a unique identification of the selected subset of the coupling structures.

Hereby, it is possible to ease the construction process. Furthermore, it is possible to build an image that requires building elements of colours and/or size and/or geometry that only slightly differs from each other.

**[0049]** It may be advantageous that the method comprises the step of selecting the at least one portion of the body structure to be illuminated by the illuminator in such a manner that the illuminator provides illumination areas of a first selection of colours not constituting all colours and/or size and/or geometry of the image. Hereby, it is possible provide a more user-friendly system that makes it possible to build an image that requires building elements of colours and/or size and/or geometry that only slightly differs from each.

**[0050]** It may be beneficial that the method comprises the step of selecting the subset of the coupling structures to be illuminated by the illuminator in such a manner that the illuminator provides illumination areas of a single colour. This

enables that colours that are nearly identical can be used in an image and that the construction can be made by using the system.

[0051] The method may comprise the step of applying an illumination device to illuminate the coupling structures and/or change the degree of illumination of the coupling structures and hereby provide a number of illumination areas, wherein the method comprises the following step of selecting a subset of the coupling structures to be illuminated by the illumination device.

[0052] It may be an advantage that the method comprises the step of selecting the subset of the coupling structures to be illuminated by the illumination device in such a manner that the illumination device provides illumination areas of a first selection of colours not constituting all colours of the image.

[0053] It may be advantageous that the method comprises the step of selecting the subset of the coupling structures to be illuminated by the illumination device in such a manner that the illumination device provides illumination areas of a single colour.

### Description of the Drawings

[0054] The invention will become more fully understood from the detailed description given herein below. The accompanying drawings are given by way of illustration only, and thus, they are not limitative of the present invention. In the accompanying drawings:

- Fig. 1 shows a perspective top view of a system according to the invention;
- Fig. 2A shows a system according to the invention in a configuration, in which the position of a first predefined colour is indicated on a plurality of pins of a bead plate by illuminating the bead plate by means of an illumination device arranged below the bead plate;
- Fig. 2B shows the system shown in Fig. 2A, in a configuration, in which beads of a first predefined colour have been attached to the pins of the bead plate, while the bead plate is being illuminated by means of the illumination device;
- Fig. 2C shows the system shown in Fig. 2B, in a configuration, in which the position of a second predefined colour is indicated on a plurality of pins of the bead plate by illuminating the bead plate by means of the illumination device arranged below the bead plate;
- Fig. 2D shows the system shown in Fig. 2C, in a configuration, in which beads of a second predefined colour have been attached to the pins of the bead plate, while the bead plate is being illuminated by means of the illumination device;
- Fig. 3A shows the system shown in Fig. 2D, in a configuration, in which the position of a third predefined colour is indicated on a plurality of pins of the bead plate by illuminating the bead plate by means of the illumination device arranged below the bead plate;
- Fig. 3B shows the system shown in Fig. 3A, in a configuration, in which beads of a third predefined colour have been attached to the pins of the bead plate, while the bead plate is being illuminated by means of the illumination device;
- Fig. 3C shows the system shown in Fig. 3B, in a configuration, in which the bead plate has been removed from the illumination device;
- Fig. 4A shows a first segment of bead plate according to the invention;
- Fig. 4B shows a second segment the bead plate shown in Fig. 4A;
- Fig. 4C shows a cross-sectional view of the segment shown in Fig. 4A;
- Fig. 4D shows a cross-sectional view of the segment shown in Fig. 4B;
- Fig. 5A shows a top view of the segments shown in Fig. 4A;
- Fig. 5B shows a cross-section of the segments shown in Fig. 5A;
- Fig. 6A shows a view of a segmented bead plate according to the invention;
- Fig. 6B shows the segmented bead plate shown in Fig. 6A in a configuration in which the remaining segment has been detachably attached to the joined segments;
- Fig. 7A shows a view of a segmented bead plate according to the invention;
- Fig. 7B shows the segmented bead plate shown in Fig. 7A in a configuration in which the remaining segment has been detachably attached to the joined segments;
- Fig. 8A shows a perspective top view of a section of a bead plate of the invention provided with a pin protruding from the flat structure of the bead plate;
- Fig. 8B shows a perspective view of the section of the bead plate shown in Fig. 8A in a configuration, in which the bead has been attached to the pin;
- Fig. 8C shows a cross-sectional view of the section of the bead plate shown in Fig. 8B;
- Fig. 8D shows a side view of the section of the bead plate shown in Fig. 8A;

- Fig. 8E shows a side view of the section of the bead plate shown in Fig. 8B;  
 Fig. 8F shows a side view of the section of the bead plate shown in Fig. 8C;  
 Fig. 8F shows a top view of the section of the bead plate shown in Fig. 8F;  
 Fig. 9B shows a perspective bottom view of the bead plate shown in Fig. 9A;  
 5 Fig. 9C shows a perspective top view of a bead plate according to the invention;  
 Fig. 9D shows a perspective bottom view of the bead plate shown in Fig. 9C;  
 Fig. 10A shows a top view of a section of a bead plate according to the invention;  
 Fig. 10B shows a perspective view of the section shown in Fig. 10A;  
 Fig. 11A shows a perspective view of a section of a bead plate according to the invention;  
 10 Fig. 11B shows a perspective view of a section of another bead plate according to the invention;  
 Fig. 11C shows a perspective view of a section of another bead plate according to the invention;  
 Fig. 11D shows a perspective view of a section of a bead plate according to the invention;  
 Fig. 11E shows a top view of the section of the bead plate shown in Fig. 11A;  
 Fig. 11F shows a top view of the section of the bead plate shown in Fig. 11B;  
 15 Fig. 11G shows a top view of the section of the bead plate shown in Fig. 11C;  
 Fig. 11H shows a top view of the section of the bead plate shown in Fig. 11D;  
 Fig. 12A shows a perspective view of a section of a body structure (formed as a bead plate) according to the invention;  
 Fig. 12B shows a perspective view of a section of a body structure (formed as a bead plate) according to the invention  
 having conical pins;  
 20 Fig. 12C shows a perspective view of a section of a body structure according to the invention provided with a plurality  
 of grooves;  
 Fig. 12D shows a perspective view of a section of a body structure (formed as a plate having receiving pins adapted  
 to receive a building block having corresponding receiving structures) according to the invention;  
 Fig. 13A shows a perspective top view of a system according to the invention;  
 25 Fig. 13B shows a perspective top view of another system according to the invention;  
 Fig. 14A shows a perspective top view of a two-piece system according to the invention in a disassembled configu-  
 ration;  
 Fig. 14B shows a perspective top view of the system shown in Fig. 14A in an assembled configuration;  
 Fig. 15A shows a top view of a section of a body structure (formed as a plate having receiving pins adapted to receive  
 30 a building block having corresponding receiving structures) according to the invention, in a configuration in  
 which two pins are illuminated from below;  
 Fig. 15B shows the section of a body structure shown in Fig. 15A, in a configuration in which three other pins are  
 illuminated from below;  
 Fig. 15C shows the section of a body structure shown in Fig. 15B, in a configuration in which two pins are illuminated  
 35 from below, wherein the illumination passes through a building brick attached to the body structure;  
 Fig. 15D shows the section of a body structure shown in Fig. 15C, in a configuration in which a single pin is illuminated  
 from below, wherein the illumination passes through two building bricks layers attached the to the body  
 structure;  
 Fig. 16A shows a section of a body structure provided with an illuminated pin;  
 40 Fig. 16B shows a section of a body structure provided with a pin, in which the central portion of the pin is illuminated;  
 Fig. 16C shows a section of a body structure provided with a pin, in which the area surrounding the pin is illuminated;  
 Fig. 16D shows a section of a body structure provided with a pin, in which a ring enclosing the pin is illuminated and  
 Fig. 16E shows a section of a body structure provided with indicators adapted to indicate the position of a pin to  
 receive a bead.

45

### Detailed description of the invention

[0055] Referring now in detail to the drawings for the purpose of illustrating preferred embodiments of the present  
 invention, a system 20 of the present invention is illustrated in Fig. 1. The system 20 is a system configured to indicating  
 50 the positions of building elements formed as beads 4 on a body structure formed as a bead plate 2 in order to build a  
 predefined image like the heart shown in Fig. 3A, Fig. 3B and Fig. 3C.

The system 20 comprises an illumination device 10 having a display portion provided with (or configured to be brought  
 into a configuration, in which the display portion is provided with) a number of activated illumination areas 12, 12",  
 wherein each activated illumination area 12, 12' emits light and thus provides an illumination 14. For simplicity, only one  
 55 illumination 14 is shown, however, in practice, all activated illumination areas 12, 12" will emit light and thus provide  
 illumination 14. The illumination areas 12, 12" can be activated by using the illumination device 10. In a preferred  
 embodiment, the illumination device 10 comprises a control unit 64 configured to select where to provide illumination  
 areas 12, 12" of a first colour (e.g. red) or a first selection of colours (e.g. yellow and blue). In a preferred embodiment,

the illumination device 10 comprises an interface by which it is possible to read instructions and/or to select among options provided in a menu or to enter values, instructions or text.

**[0056]** In one embodiment, the illumination device 10 is configured to provide illumination 14 of a predefined colour, preferably corresponding to the colour of the bead(s) to be arranged in the position(s) indicated on a bead plate 2 arranged above illumination device 10.

**[0057]** In another embodiment, the illumination device 10 is configured to provide illumination 14 of white light (a combination of lights of different wavelengths in the electromagnetic spectrum). In this embodiment the illumination device 10 is configured to indicate the colour of bead(s) to be arranged in the position(s) indicated on a bead plate 2 arranged above illumination device 10 by other means (e.g. text or sound such as "Please, place blue beads into the illuminated pins").

**[0058]** The user may download an image from an internal source such a local storage 46 of the illumination device 10, from an external source such as a server 40 in a manner that includes communication 39, 39' between the illumination device 10 and the server 40 or from the Internet 42 in a manner that includes communication 38, 38' between the illumination device 10 and the Internet 42. Besides, communication 38 may be carried out between the server 40 and the Internet 42.

The illumination device 10 may be a tablet, a smartphone a computer or a dedicated electric device comprising a display unit configured to provide activated illumination areas 12, 12" in order to indicate the colour of the bead(s) to be arranged in predefine position(s) indicated on a bead plate 2 arranged above illumination device 10.

**[0059]** In Fig. 1 a transparent bead plate 2 is arranged above the illumination device 10. The bead plate 2 is intended to be arranged on the display unit (top portion) of the illumination device 10 in a fixed and predefined manner, so that the position of the activated illumination areas 12, 12" can be used to indicate the colour of the bead(s) to be arranged in predefine position(s) indicated on a bead plate 2 arranged above illumination device 10. Accordingly, it is required to know the position of the pins 6 of the bead plate 2 and the position at which the bead plate 2 is attached to/arranged on the illumination device 10. In a preferred embodiment, the illumination device 10 comprises an indication structure 44 indicating the position, at which the bead plate 2 is required to be attached to/arranged on the illumination device 10.

**[0060]** The bead plate 2 comprises a flat structure 8, from which a plurality of pins 6 protrude. The pins 6 are configured to receive beads (see Fig. 2B).

**[0061]** Fig. 2A illustrates a system 20 according to the invention in a configuration, in which the positions of a first predefined colour (the pins 6 at which red beads have to be attached on the body structure formed as a bead plate 2 arranged on the illumination device 10) is indicated on a plurality of coupling elements formed as pins 6 of the bead plate 2 by illumination of the bead 2 plate by means of an illumination device 10 arranged below the bead plate 2.

**[0062]** The bead plate 2 comprises a flat structure 8 formed as a transparent planar plate. A plurality of pins 6 protrudes from the flat structure 8. The longitudinal axes of the pins 6 extend perpendicular to the plane along which the flat structure 8 extends.

Since the system 20 enables that a single colour is indicated by means of the illumination device 10, the system enables that colours that only slightly differs can be used when constructing an image. This approach is not possible if all colours are indicated at one time. Accordingly, it is a major advantage that the system 20 and the method according to the invention enables selection of a subset of colours to be indicated by means of the illumination device 10. This subset of colours may be a single colour (e.g. a blue colour, a read colour, a green colour or another predefined colour). The subset of colours may include several colours (e.g. read and blue, green and purple or orange, pink and green).

**[0063]** Fig. 2B illustrates the system 20 shown in Fig. 2A, in a configuration, in which building elements formed as beads 4 of a first predefined colour have been attached to the pins of the bead plate 2, while the bead plate 2 is being illuminated by means of the illumination device 10.

**[0064]** Fig. 2C illustrates the system 20 shown in Fig. 2B, in a configuration, in which the position of a second predefined colour is indicated on a plurality of the coupling elements formed as pins 6', 6" (not being illuminated in Fig. 2A) of the bead plate 2. This indication is made by illuminating the bead plate 2 by means of the illumination device 10 arranged below the bead plate 2. In a preferred embodiment, the bead plate 2 is provided with a positioning unit (not shown) configured to keep the bead plate 2 in a fixed position and orientation relative to the illumination device 10. The positioning unit may be provided as an anti-slip structure provided at the bottom end of the bead plate 2. The anti-slip structure may be provided as a mat providing a friction large enough to maintain the mat and thus the bead plate 2 in a fixed position and orientation relative to the illumination device 10.

**[0065]** Instead of indicating only a single colour by means of the illumination device 10, it is possible to indicate a group of colours defining a subset of the colours of the image to be constructed by using the bead plate 2. This may be done, e.g. by illuminating a plurality of pins 6' of the bead plate 2 by means of the illumination device 10.

Fig. 2D illustrates the system 20 shown in Fig. 2C, in a configuration, in which building elements formed as beads 4' of a second predefined colour have been attached to the pins of the bead plate 2, while the bead plate 2 is being illuminated by means of the illumination device 10.

**[0066]** Fig. 3A illustrates the system 20 shown in Fig. 2D, in a configuration, in which the position of a third predefined

colour is indicated on a plurality of coupling structures formed as pins 6" of the body structure formed as a bead plate 2 by illuminating these pins 6" by means of the illumination device 10, onto which the bead plate 2 is arranged. It can be seen that the beads 4 of the first colour and the beads 4' of the second colour are maintained in their position, onto which they were arranged as explained with reference to Fig. 2D.

5 **[0067]** Fig. 3B illustrates the system 20 shown in Fig. 3A, in a configuration, in which beads 4" of a third predefined colour have been attached to the remaining pins (indicated with reference number 6" in Fig. 3A) of the bead plate 2, while the bead plate 2 is being illuminated by means of the illumination device 10.

10 **[0068]** Fig. 3C illustrates the system 20 shown in Fig. 3B, in a configuration, in which the bead plate 2 has been removed from the illumination device 10. The beads 4, 4', 4" arranged on the bead plate 2 constitute a construction (e.g. an image) 48 of a heart. The beads 4, 4', 4" may now be heated e.g. by means of a flat iron in order to join the beads 4, 4', 4". It may be an advantage to use flat bottom iron.

**[0069]** It can be seen that the illumination device 10 has a plurality of activated illumination areas 12" each emitting light and thus provides an illumination that assisted the user to position the beads 4" in the pins (6" shown in Fig. 3A).

15 **[0070]** Fig. 4A illustrates a first segment 22 of bead plate 2 according to the invention, whereas Fig. 4B illustrates a second segment 22' of the bead plate 2 shown in Fig. 4A. The first segment 22 is configured to be attached to the second segment 22'. Fig. 4C illustrates a cross-sectional view of the segment 22 shown in Fig. 4A, whereas Fig. 4D illustrates a cross-sectional view of the segment 22' shown in Fig. 4B.

20 **[0071]** The first segment 22 and the second segment 22' each comprises a flat structure provided with pins (not shown for reasons of simplicity). The segments 22, 22' have rectangular body portion having a first side length  $L_3$  in and a second side length  $L_4$ . In one embodiment, the first side length  $L_3$  corresponds to the second side length  $L_4$ .

**[0072]** In another embodiment, the first side length  $L_3$  differs from the second side length  $L_4$ .

25 **[0073]** The first segment 22 is provided with attachment structures 16, 16' extending in extension of the rectangular body portion of the first segment 22. The attachment structures 16, 16' are positioned in side by side manner, in which a space is provided between adjacent attachment structures 16, 16'. An angled portion 28, 28' is provided at each side structure of each of the attachment structures 16, 16'.

30 **[0074]** In Fig. 4C it can be seen that every second attachment structure 16 is arranged in a higher level than the remaining attachment structures 16'. Likewise, in Fig. 4D it can be seen that every second attachment structure 18 is arranged in a higher level than the remaining attachment structures 18'. Each of the attachment structures 16, 16', 18, 18' comprise an engagement portion 32, 32' configured to engage with a corresponding engagement portion 32, 32' of an attachment structure 16, 16', 18, 18' of the adjacent segment 22, 22' that is attached by means of the attachment structures 16, 16', 18, 18'.

35 **[0075]** Each of the attachment structures 16, 16', 18, 18' comprise a flat portion 34, 34' provided next to the engagement portion 32, 32'. The attachment structure 16 (positioned in a high level) of the segment 22 shown in Fig. 4C is configured to be engagingly attached to the corresponding attachment structure 18' (positioned in a low level) of the segment 22'. Accordingly, the engagement portion 32 of the attachment structure 16 of the segment 22 will engage with the engagement portion 32' of the attachment structure 18' of the segment 22'.

40 **[0076]** The length  $L_1$  of the short attachment structures 16', 18' is smaller than the length  $L_2$  of the long attachment structures 16, 18. Hereby, it is, as shown in Fig. 6A and Fig. 6B as well as Fig. 7A and Fig. 7B, possible to slide a segment 22'" into engagement with segments 22, 22', 22" already being attached to each other.

**[0077]** Fig. 5A illustrates a top view of the segments 22, 22' shown in Fig. 4A and Fig. 4B, in a configuration, in which the segments 22, 22' of a bead plate 2 are joint (detachably attached to each other). Fig. 5B illustrates a cross-section of the segments 22, 22' shown in Fig. 5A. The longitudinal axis X, the lateral axis Y as well as the normal axis Z of the second segment 22' are indicated in Fig. 5A.

45 **[0078]** The engagement portion 32 of the attachment structure 16 of the first segment 22 is brought into lockingly engagement with the corresponding engagement portion 32' of the attachment structure 18' of the second segment 22'. The longitudinal axis and the normal axis Z of the second segment 22' are indicated in Fig. 5B. It can be seen that the attachment structure 16 of the first segment 22 of the bead plate 2 can be brought out of engagement with the attachment structure 18' of the second segment 22' of the bead plate 2 by moving the attachment structure 16 along the normal axis Z of the second segment 22'.

50 **[0079]** Fig. 6A illustrates a view of a segmented bead plate 2 according to the invention. The bead plate 2 comprises four segments 22, 22', 22", 22'" shaped as the segments shown in Fig. 4A, Fig. 4B, Fig. 4C, Fig. 4D, Fig. 5A and Fig. 5B. In a preferred embodiment, the segments 22, 22', 22", 22'" are equally shaped in order to reduce the number of tools for manufacturing the segments 22, 22', 22", 22'" . The segments 22, 22', 22" are already joint (detachably attached to each other), whereas the remaining segment 22'" is ready to be attached to the segments 22, 22" .

55 **[0080]** In Fig. 6B, the segment 22'" has been detachably attached to the segments 22, 22" . Accordingly, the bead plate 2 is assembled and comprises four segments 22, 22', 22", 22'" being attached to each other. It can be seen that an aperture 36 is provided at the central portion of the bead plate 2 at the position, at which all four segments 22, 22', 22", 22'" are attached to each other.

**[0081]** Fig. 7A illustrates a view of a segmented bead plate 2 according to the invention. The bead plate 2 comprises four segments 22, 22', 22'', 22''' shaped as the segments corresponding to the ones shown in Fig. 6A. The segments 22, 22', 22'' are already joint (detachably attached to each other), whereas the remaining segment 22''' is ready to be attached to the segments 22, 22'. The segment 22'' comprises attachment structures 16, 16', wherein the segment 22''' comprises corresponding attachment structures 18, 18' configured to be detachably attached to the attachment structures 16, 16' of the segment 22'' in a manner as explained with reference to Fig. 5A and Fig. 5B.

**[0082]** In Fig. 7B, the segment 22''' has been detachably attached to the segments 22, 22''. Therefore, the bead plate 2 is in an assembled configuration, in which the four segments 22, 22', 22'', 22''' being attached to each other. Fig. 8A illustrates a perspective top view of a section of a bead plate of the invention provided with a pin 6 protruding from the flat structure 8 of the bead plate. A bead 4 provided with a centrally arranged hole 24 is arranged above the pin 6. The diameter  $D_1$  of the hole 24 is smaller than the diameter  $D_2$  of the pin 6. The pin 6 comprises a base portion 50 having a basically triangular cross section and three edge portions 52 extending in extension of the base portion 50. The edge portions 52 are configured to provide a radially directed force (F see Fig. 8C) towards the bead 4 when being attached to the bead 4 because the diameter  $D_2$  of the pin 6 is larger than the diameter  $D_1$  of the hole 24. The pin 6 comprises a top portion 54.

**[0083]** Fig. 8B illustrates a perspective view of the section of the bead plate 2 shown in Fig. 8A in a configuration, in which the bead 4 has been attached to the pin 6.

**[0084]** Fig. 8C illustrates a cross-sectional view of the section of the bead plate shown in Fig. 8B. It can be seen that the edge portions of the pin 6 provides a radially directed force F to the inside structure of the bead 4. Accordingly, the bead 4 is radially deformed to form broadened portions 56.

**[0085]** Fig. 8D illustrates a side view of the section of the bead plate shown in Fig. 8A. Fig. 8E illustrates a side view of the section of the bead plate shown in Fig. 8B and Fig. 8F illustrates a side view of the section of the bead plate shown in Fig. 8C. Fig. 8F illustrates a top view of the section of the bead plate shown in Fig. 8F. In a preferred embodiment, the beads 4 are selected in such a manner that the inside diameter  $D_1$  of the hole 24 is smaller than the diameter  $D_2$  of the pin 6. Hereby, it is possible to

**[0086]** Fig. 9A illustrates a perspective top view of a bead plate 2 according to the invention. The bead plate 2 comprises a flat structure 8 provided with a plurality of pins 6 protruding therefrom. The pins 6 are shaped as the pin illustrated in Fig. 8A.

**[0087]** Fig. 9B illustrates a perspective bottom view of the bead plate 2 shown in Fig. 9A. It can be seen that the backside of the flat structure is provided with coating 58. This coating 58 is preferably made in any suitable high friction coating material, e.g. a rubber material. The coating 58 may e.g. be a silicone rubber or a synthetic rubber such as polychloroprene (neoprene) or acrylonitrile butadiene rubber. A plurality of holes 62 are provided in the coating 58. These holes 62 are arranged so that light from an illumination device (see Fig. 1) can illuminate the pins 6 (shown in Fig. 9A) through the holes 62.

**[0088]** Fig. 9C illustrates a perspective top view of a bead plate 2 according to the invention. The bead plate 2 comprises a flat structure 8 and a plurality of pins 6 protruding therefrom. The pins 6 are shaped as the pin illustrated in Fig. 8A.

**[0089]** Fig. 9D illustrates a perspective bottom view of the bead plate 2 shown in Fig. 9C. It can be seen that the backside of the flat structure is provided with a mat 60. The mat 60 is preferably made in any suitable high friction material, e.g. a rubber material. The mat 60 may be made from silicone rubber or a synthetic rubber such as polychloroprene (neoprene) or acrylonitrile butadiene rubber. A plurality of holes 62' are provided in the mat 60. These holes 62' are positioned in a manner, in which light from an illumination device (see Fig. 1) is capable of illuminating the pins 6 (shown in Fig. 9C) through the holes 62'.

**[0090]** Fig. 10A illustrates a top view of a section of a bead plate 2 according to the invention. Fig. 10B illustrates a perspective view of the section shown in Fig. 10A. The bead plate 2 comprises a flat structure 8 provided with a plurality of pins 6. Beads 4 are attached to a selection of the pins. The pins 6 are shaped as the one shown in Fig. 8A.

**[0091]** Fig. 11A illustrates a perspective view of a section of a bead plate 2 according to the invention. Fig. 11E illustrates a top view of the section of the bead plate 2 shown in Fig. 11A. The bead plate 2 comprises a flat structure 8 provided with a pin 6 having a basically rectangular base portion 50 and edge portions 52 extending in extension of the base portion 50. The pin 6 comprises a rectangular top portion 54.

Fig. 11B illustrates a perspective view of a section of another bead plate 2 according to the invention. Fig. 11F illustrates a top view of the section of the bead plate 2 shown in Fig. 11B. The bead plate 2 comprises a flat structure 8 provided with a pin 6 having a basically triangular base portion 50 and edge portions 52 extending in extension of the base portion 50. The pin 6 comprises a triangular top portion 54.

**[0092]** Fig. 11C illustrates a perspective view of a section of another bead plate 2 according to the invention. Fig. 11G illustrates a top view of the section of the bead plate 2 shown in Fig. 11C. The bead plate 2 comprises a flat structure 8 provided with a pin 6 having a basically square base portion 50 and edge portions 52 extending in extension of the base portion 50. The pin 6 comprises a square top portion 54.

**[0093]** Fig. 11D illustrates a perspective view of a section of another bead plate 2 according to the invention. Fig. 11H

illustrates a top view of the section of the bead plate 2 shown in Fig. 11D. The bead plate 2 comprises a flat structure 8 provided with a pin 6 having a base portion 50 having a cross section that basically corresponds to a square provided with a circle in each corner and edge portions 52 extending in extension of the base portion 50. The pin 6 comprises a square top portion 54.

5 [0094] Fig. 12A illustrates a perspective view of a section of a body structure 2 according to the invention. The body structure 2 is formed as a bead plate 2 comprising a planar plate member having an upper flat structure 8. The body structure 2 comprises a plurality of pins 6 protruding from the flat structure 8. The pins 6 are evenly distributed on the flat structure 8. The pins 6 have a geometry corresponding to the pin shown in Fig. 11B. It is, however, possibly to use pins of a different geometry. Two beads 4' have already been attached to pins 6 of the bead plate 2. One additional bead 4 is arranged above the bead plate 2 and can be attached to one of the remaining pins 6 when a light-based signal indicates to which pin 6, the bead 4 is intended to be attached.

10 [0095] Fig. 12B illustrates a perspective view of a section of a body structure 2 according to the invention that is provided with conical pins 6 protruding from a flat structure 8 of the body structure 2. The pins 6 are evenly distributed on the flat structure 8. Two cylindrical objects formed as beads 4' provided with a through-going bore have already been attached to pins 6 of the body structure 2. One additional bead 4 having a through-going bore is arranged above the body structure 2 and can be attached to one of the remaining pins 6 when a light-based signal indicates to which pin 6, the bead 4 is intended to be attached.

15 [0096] Fig. 12C illustrates a perspective view of a section of a basically plate-shaped body structure 2 according to the invention provided with a plurality of grooves 5, 5'. The grooves 5, 5' have a semi-spherical shape and being evenly distributed on a flat structure 8 of the body structure 2. The grooves 5, 5' are configured to receive building structures 7, 7' having a substantially spherical geometry. Two ball-shaped building structures 7' are already positioned in and hereby received by grooves 5, 5' of the body structure 2. One additional ball-shaped building structure 7 is arranged above the body structure 2 and can be put into one of the remaining grooves 5, 5' when a light-based signal indicates into which groove 5, 5' the ball-shaped building structure 7 is intended to be arranged.

20 [0097] Fig. 12D illustrates a perspective view of a section of a body structure 2 according to the invention. The body structure 2 is formed as a plate having receiving pins 6 adapted to receive building blocks 9, 9' having corresponding receiving structures (not shown). The pins 6 protrude from a flat structure 8 of the body structure 2. Two building blocks 9' have been attached to the receiving pins 6 of the body structure 2. One additional building block 9 is arranged above the body structure 2 and is ready to be attached to the body structure 2. The invention makes it possible to use a light-based signal to indicate where to attach the building block 9. Hereby, the user can be assisted to build complex structures. The building blocks 9, 9' may be transparent and thus it is possible construct several layers (more building blocks 9' put on the top of each other) by using the invention.

25 [0098] Fig. 13A illustrates a perspective top view of a system 20 according to the invention. The system 20 comprises a body structure 2 having a flat structure 8 and a plurality of pins 6 protruding therefrom. The system 20 comprises a build-in (integrated) illumination device having a display portion provided with (or configured to be brought into a configuration, in which the display portion is provided with) a number of activated illumination areas (that may be arranged below the pins 6) that are configured to be activated and inactivates hereby either increasing or decreasing the amount of light 14 emitted by the illumination areas. Thus, the system 20 can change the degree of illumination 14. For simplicity, only one illumination 14 is shown, however, in practice, all activated illumination areas are configured to emit light and thus provide illumination 14.

30 [0099] Indication of the pins 6 to which a bead or another building structure is intended to be attached can be indicated by providing an illumination 14, increasing the illumination 14, decreasing the illumination 14 or removing the illumination 14 (e.g. if the remaining pins are still illuminated).

35 [0100] It is possible to have an illumination device (not shown) that is configured to provide illumination 14 of a predefined colour, preferably corresponding to the colour of the bead(s) or other building structures to be arranged in the position(s) indicated on the body structure 2. The illumination device may be configured to provide illumination 14 of white light (a combination of lights of different wavelengths in the electromagnetic spectrum). In this embodiment the illumination device may be configured to indicate the colour of bead(s) or other building structures to be arranged in the position(s) indicated on the body structure 2 by other means (e.g. text or sound such as "Please, place blue beads into the illuminated pins". The body structure 2 is provided with a storage 46 and a control unit 64 that may be used in the same manner as explained with reference to Fig. 1.

40 [0101] Fig. 13B illustrates a perspective top view of another system 20 according to the invention. The system 20 basically corresponds to the system 20 shown in Fig. 13A. The system 20 in Fig. 13A, however, comprises two separate components:

- 45
- 50
- 55
- 1) a body structure 2 having a flat structure 8 and a plurality of pins 6 protruding therefrom and a build-in illumination device having a display portion provided with a number of activated illumination areas (that may be arranged below the pins 6) that are configured to be activated and inactivates hereby either increasing or decreasing the amount of

light 14 emitted by the illumination areas and

2) a control structure 66 comprising a storage 46 and a control unit 64. The control structure 66 is configured to communicate wirelessly with a communication module (not shown) of the body structure 2. Accordingly, wireless signals 38 can be sent to the body structure 2 by the control structure 66 and the control structure 66 can receive wireless signals 38 sent by the communication module of the body structure 2.

**[0102]** Fig. 14A illustrates a perspective top view of a two-piece system 20 according to the invention in a disassembled configuration. Fig. 14B illustrates a perspective top view of the system 20 shown in Fig. 14A in an assembled configuration.

**[0103]** The system 20 basically corresponds to the system shown in Fig. 13B. The system 20 in Fig. 14A, however, comprises a body structure 2 provided with a socket structure 68, whereas the control structure 66 comprises a plug 70 configured to electrically connect the control structure 66 to the body structure 2 by inserting the plug 70 into the socket structure 66. Accordingly, communication between the body structure 2 and the control structure 66 is conducted by using a wired connection by means of the plug 70.

**[0104]** Fig. 15A illustrates a top view of a section of a body structure 2 (formed as a plate having receiving pins 6, 6' adapted to receive a building block having corresponding receiving structures) according to the invention, in a configuration in which two pins 6, 6' are illuminated from below. Accordingly, illumination 14 is visible through the pins 6, 6' and the user knows that a building brick has to be attached to the illuminated pins 6, 6'.

**[0105]** Fig. 15B illustrates the section of a body structure 2 shown in Fig. 15A, in a configuration in which three other pins 6, 6' are illuminated from below. A first building brick 9' has been attached to the pins illuminated in Fig. 15A. Another building brick 9 is arranged above the body structure 2. This other is to be attached to three illuminated pins 6, 6'.

**[0106]** Fig. 15C illustrates the section of a body structure 2 shown in Fig. 15B, in a configuration in which two pins are illuminated from below, wherein the illumination passes through a building brick 9 attached to the body structure 2. The building brick 9 has been attached to the pins illuminated in Fig. 15B. An additional building brick 9'' is arranged above the body structure 2 and is ready to be attached to two illuminated pins of the building brick 9. This can be accomplished by using transparent or semi-transparent building blocks 9.

**[0107]** Fig. 15D illustrates the section of a body structure 2 shown in Fig. 15C, in a configuration in which a single pin is illuminated from below, wherein the illumination passes through two building bricks 9, 9''. An additional building brick 9''' is arranged above the body structure 2 and is ready to be attached to an illuminated pin of the uppermost building brick 9'''.

**[0108]** Fig. 16A illustrates a section of a body structure 2 provided with an illuminated pin 6. The body structure 2 is a bead plate 2 provided with pins 6 protruding from a flat structure of the bead plate 2. A bead 4 is arranged above the illumination 14 of the bead plate 2. The entire pin 6 is illuminated.

**[0109]** Fig. 16B illustrates a section of a body structure 2 provided with a pin 6, in which the central portion of the pin 6 is illuminated. The illumination 14 is enough to enable a unique identification of the selected subset of the pin 6.

**[0110]** Fig. 16C illustrates a section of a body structure 2 provided with a pin 6, in which the area surrounding the pin 6 is illuminated. Accordingly, a large and clear illumination 14 is provided. Thus, it is possible to identify the pin 6 that has to receive a bead 4 arranged above the bead plate 2.

**[0111]** Fig. 16D illustrates a section of a body structure 2 provided with a pin 6, in which a ring enclosing the pin 6 is illuminated. The illumination 14 is enough to enable a unique identification of the selected subset of the pin 6 and thus identify the pin 6 that has to receive a bead 4 arranged above the bead plate 2.

**[0112]** Fig. 16E illustrates a section of a body structure 2 provided with indicators 15, 15' adapted to indicate the position of a pin 6 to receive a bead 4 arranged above the bead plate 2.

**List of reference numerals**

**[0113]**

2	Bead plate
4, 4', 4''	Bead
5, 5'	Groove
6, 6', 6''	Pin
7, 7'	Building structure
8	Flat structure
9, 9', 9'', 9'''	Building brick
10	Illumination device
12, 12''	Illumination area
14	Illumination
15, 15'	Indicator

	16, 16'	Attachment structure
	18, 18'	Attachment structure
	20	System
	22, 22', 22", 22'''	Segment
5	24	Hole
	25	Notch
	26, 26'	Angled portion
	28, 28'	Angled portion
	32, 32'	Engagement portion
10	34, 34'	Flat portion
	36	Aperture
	37, 38, 38', 39, 39'	Communication
	40	External server
	42	Internet
15	44	Indication structure
	46	Storage
	48	Construction
	50	Base portion
	52	Edge portion
20	54	Top portion
	56, 56'	Broadened portion
	58	Coating
	60	Mat
	62, 62'	Hole
25	64	Control unit
	66	Control structure
	68	Socket structure
	70	Plug
	L <sub>1</sub> , L <sub>2</sub> , L <sub>3</sub> , L <sub>4</sub>	Length
30	X, Y, Z	Axis
	F	Force
	D <sub>1</sub> , D <sub>2</sub>	Diameter

35 **Claims**

1. A system (20) for assisting a user to build a construction (48) on a body structure (2) comprising a plurality of coupling structures (5, 5', 5", 6, 6', 6") arranged on a base portion (8) and being configured to receive a building element (4, 4', 4", 7, 7', 9, 9'), wherein the system (20) comprises:
  - 40 - an illuminator (10) configured to provide illumination of at least a portion of the body structure (2) and hereby provide a number of illumination areas (12, 12"), **characterised in that** the system (20) comprises a control unit (64) configured to be applied to select a subset of the coupling structures (5, 5', 5", 6, 6', 6") and initiate an illumination (14) that enables a unique identification of the selected subset of the coupling structures (5, 5', 5", 6, 6', 6") to be established by means of the illumination (14).
2. A system (20) according to claim 1, **characterised in that** the illuminator (10) is configured to provide illumination of at least a portion of the body structure (2) from below.
- 50 3. A system (20) according to claim 1 or 2, **characterised in that** the body structure (2) is a bead plate (2) comprising a plurality of pins (6, 6', 6") protruding from a base portion (8) and being configured to receive a bead (4, 4', 4"), wherein the system comprises an illumination device (10) configured to illuminate the pins (6, 6', 6") or one or more areas that enables an unique identification of a selected subset of the pins (6, 6', 6").
- 55 4. A system (20) according to one of the preceding claims 1-3, **characterised in that** the illumination device (10) comprises a control unit (64) configured to be applied to select a subset of the coupling structures (5, 5', 5", 6, 6', 6") to be illuminated by the illumination device (10).

- 5
5. A system (20) according to one of the preceding claims, **characterised in that** the control unit (64) is configured to select the subset of the coupling structures (5, 5', 5", 6, 6', 6") to be illuminated by the illumination device (10) in such a manner that the illumination device (10) provides illumination areas (12, 12") of a first selection of colours not constituting all colours of the image (46).
- 10
6. A system (20) according to claim 5, **characterised in that** the control unit (64) is configured to select the subset of the coupling structures (5, 5', 5", 6, 6', 6") to be illuminated by the illumination device (10) in such a manner that the illumination device (10) provides illumination areas (12, 12") of a single colour.
- 15
7. A system (20) according to one of the preceding claims, **characterised in that** the control unit (64) is configured to receive feedback from the user, when the user has finished inserting beads (4, 4', 4") of a predefined group of colours or a single predefined colour, wherein the control unit (64) is configured to hereafter illuminate coupling structures (5, 5', 5", 6, 6', 6") that has not been illuminated.
- 20
8. A system (20) according to one of the preceding claims, **characterised in that** the system (20) comprises a body structure (2) having a plurality of segments (22, 22', 22", 22'") configured to be detachably attached to each other.
- 25
9. A system (20) according to claim 8, **characterised in that** the segments (22, 22', 22", 22'") each comprises a plurality of attachment structures (16, 16', 18, 18') extending in extension of the base portion (8) of the segment (22, 22', 22", 22'") 18')
- 30
10. A system (20) according to one of the preceding claims, **characterised in that** the body structure comprises pins (6, 6', 6") provided with edge portions (52) configured to provide a radially directed force (F) towards a building element (4, 4', 4", 7, 7', 9, 9') when the building element (4, 4', 4", 7, 7', 9, 9') is being attached to a pin (6, 6', 6").
- 35
11. A system (20) according to one of the preceding claims, **characterised in that** the body structure (2) is provided with a positioning unit (58, 60) configured to keep the body structure (2) in a fixed position and orientation relative to the illumination device (10).
- 40
12. A method for assisting a user to build a construction (48) on a body structure (2) comprising a plurality of coupling structures (5, 5', 6, 6', 6") arranged on a base portion (8) and being configured to receive a building element (4, 4', 4", 7, 7', 9, 9'), wherein the method comprises the step of applying an illuminator (10) to illuminate at least a portion of the body structure (2) and/or change the degree of illumination of at least a portion of the body structure (2) and hereby provide a number of illumination areas (12, 12"), **characterised in that** the method comprises the following step:
- selecting a subset of the coupling structures (5, 5', 5", 6, 6', 6");
  - illuminating at least a portion of the body structure (2) and hereby enabling a unique identification of the selected subset of the coupling structures (5, 5', 5", 6, 6', 6").
- 45
13. A method according to claim 12, **characterised in that** the method comprises the step of selecting the at least one portion of the body structure (2) to be illuminated by the illuminator (10) in such a manner that the illuminator (10) provides illumination areas (12, 12") of a first selection of colours not constituting all colours and/or size and/or geometry of the image (46).
- 50
14. A method according to claim 13, **characterised in that** the method comprises the step of selecting the subset of the coupling structures (5, 5', 6, 6', 6") to be illuminated by the illuminator (10) in such a manner that the illuminator (10) provides illumination areas (12, 12") of a single colour.
- 55

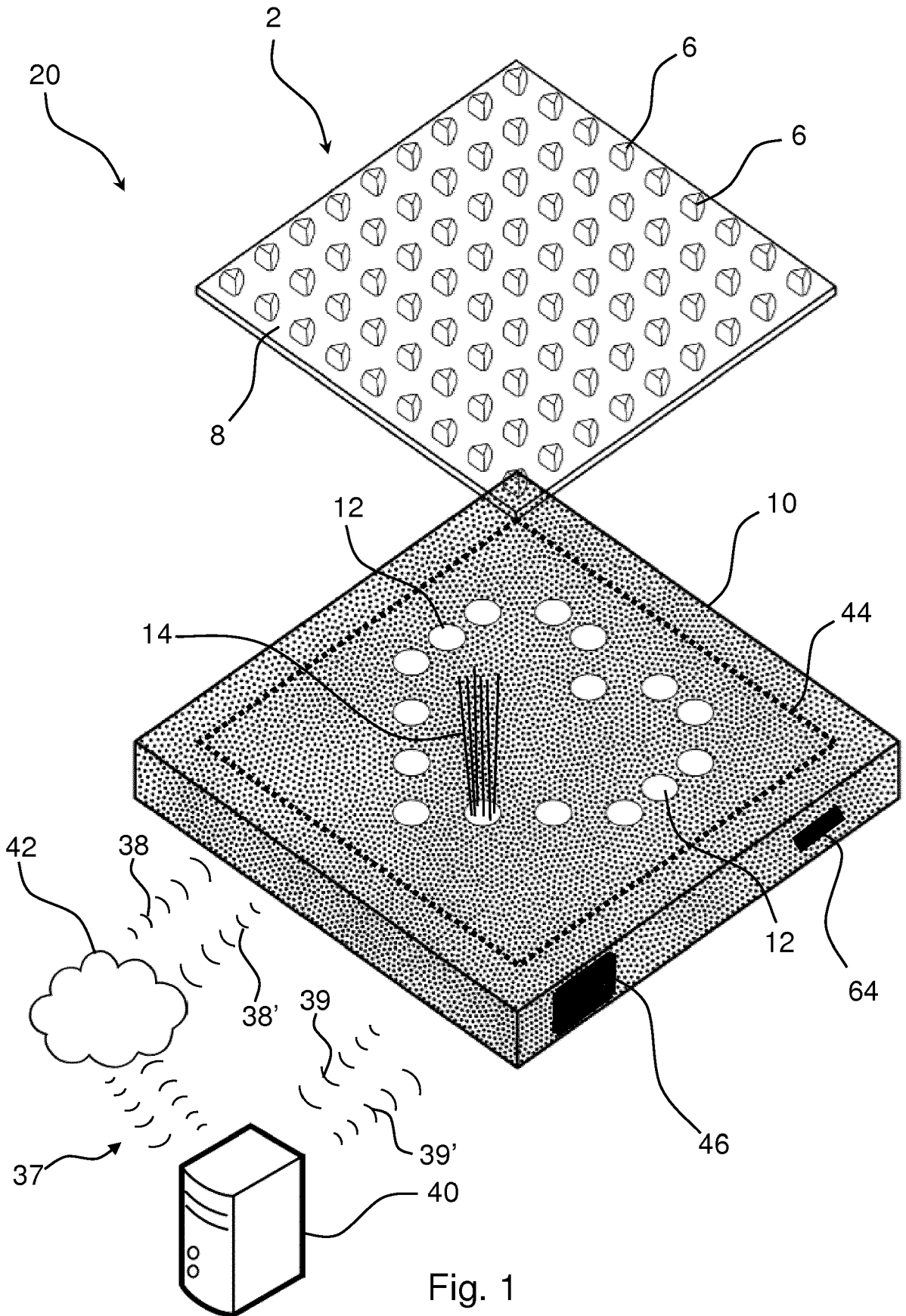

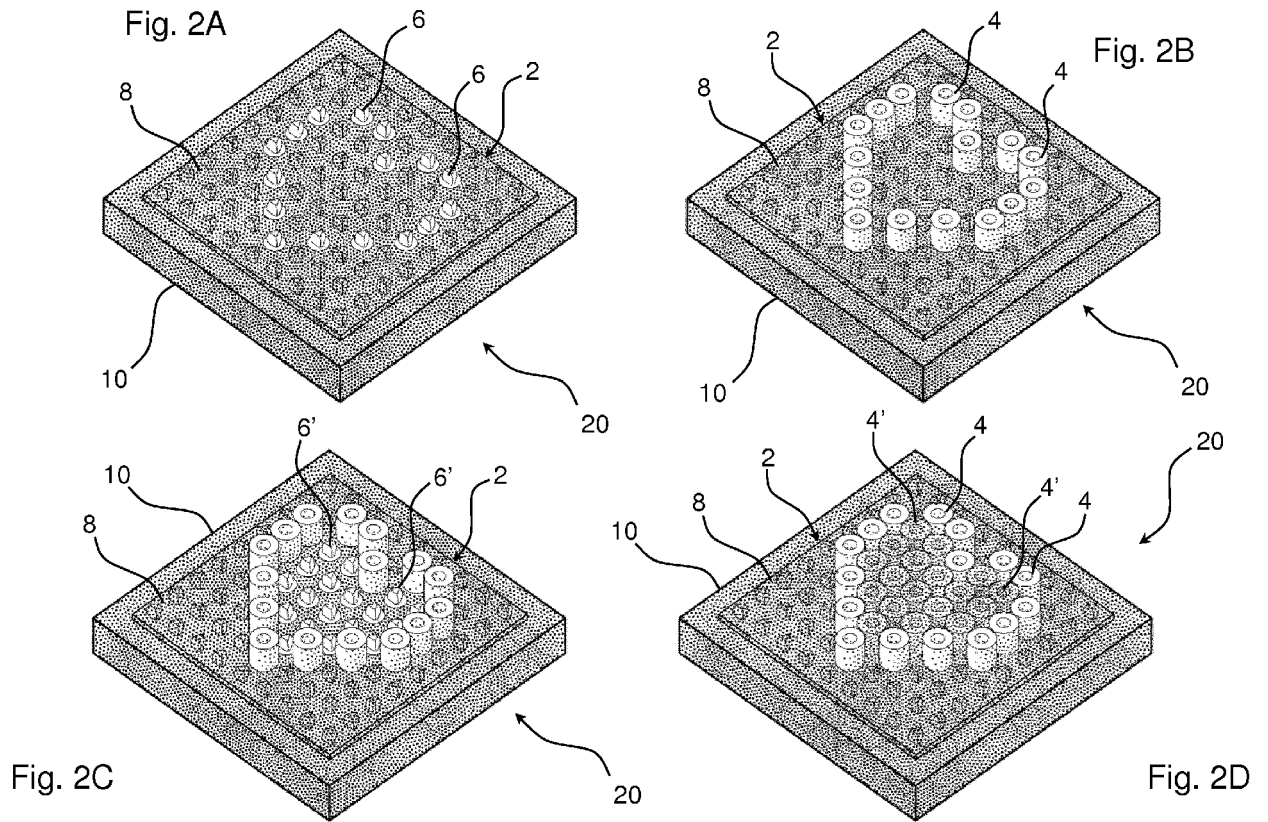

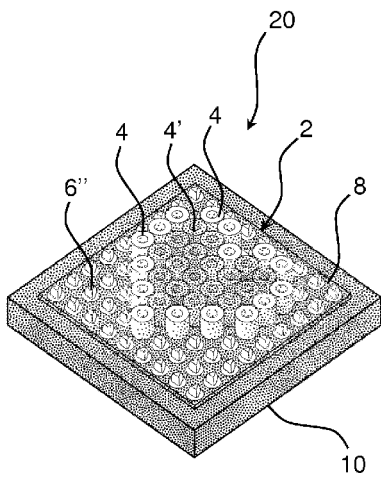

Fig. 3A

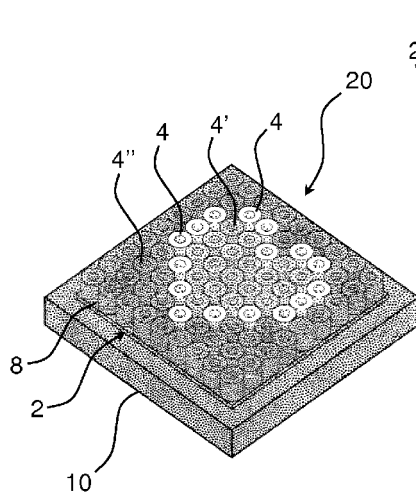

Fig. 3B

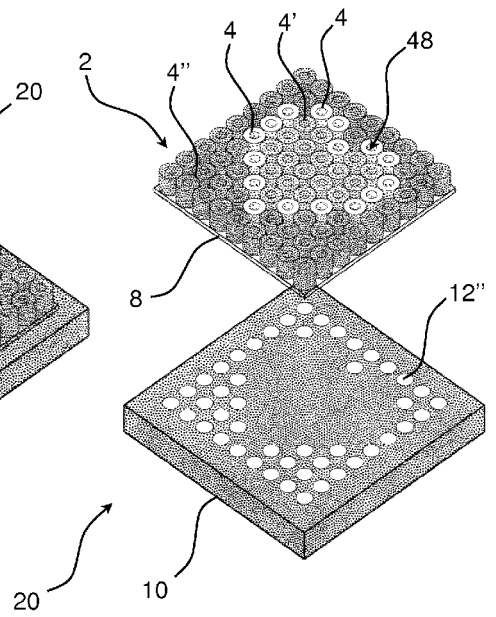

Fig. 3C

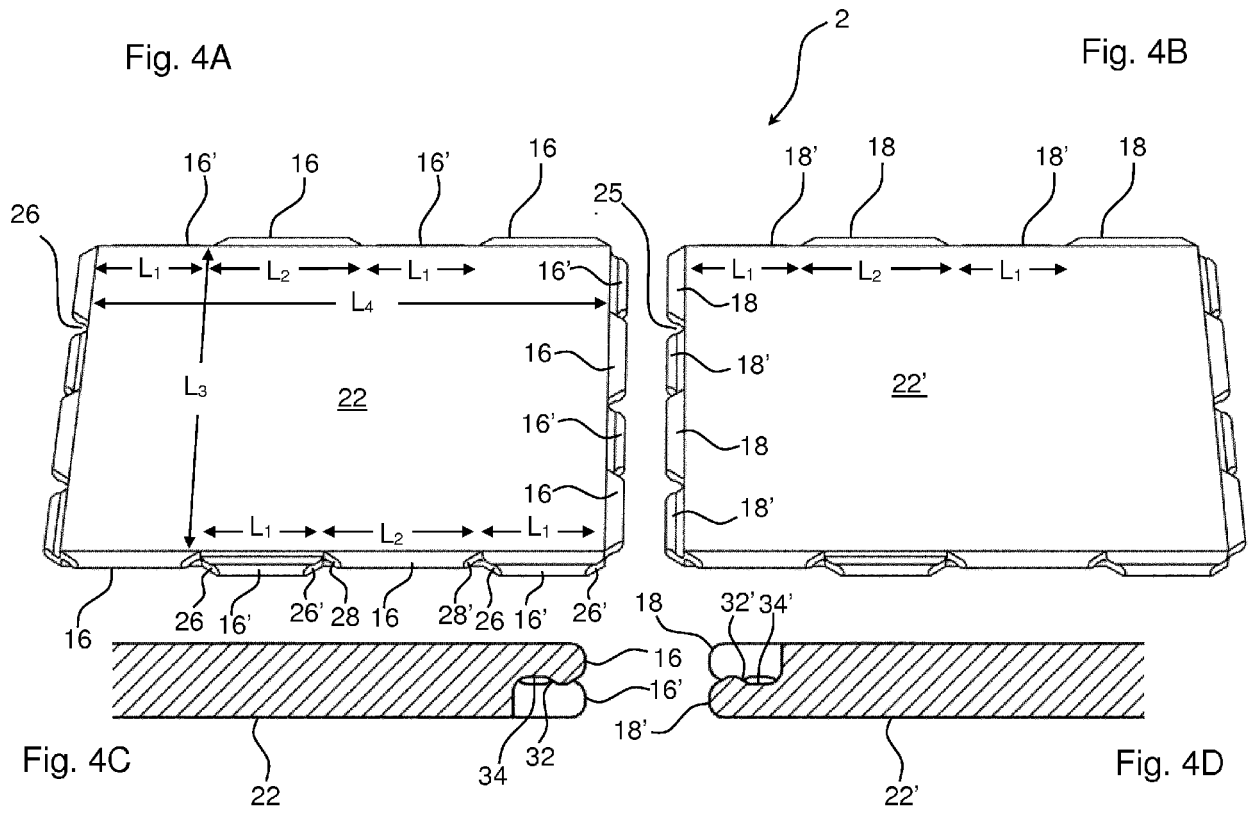

Fig. 5A

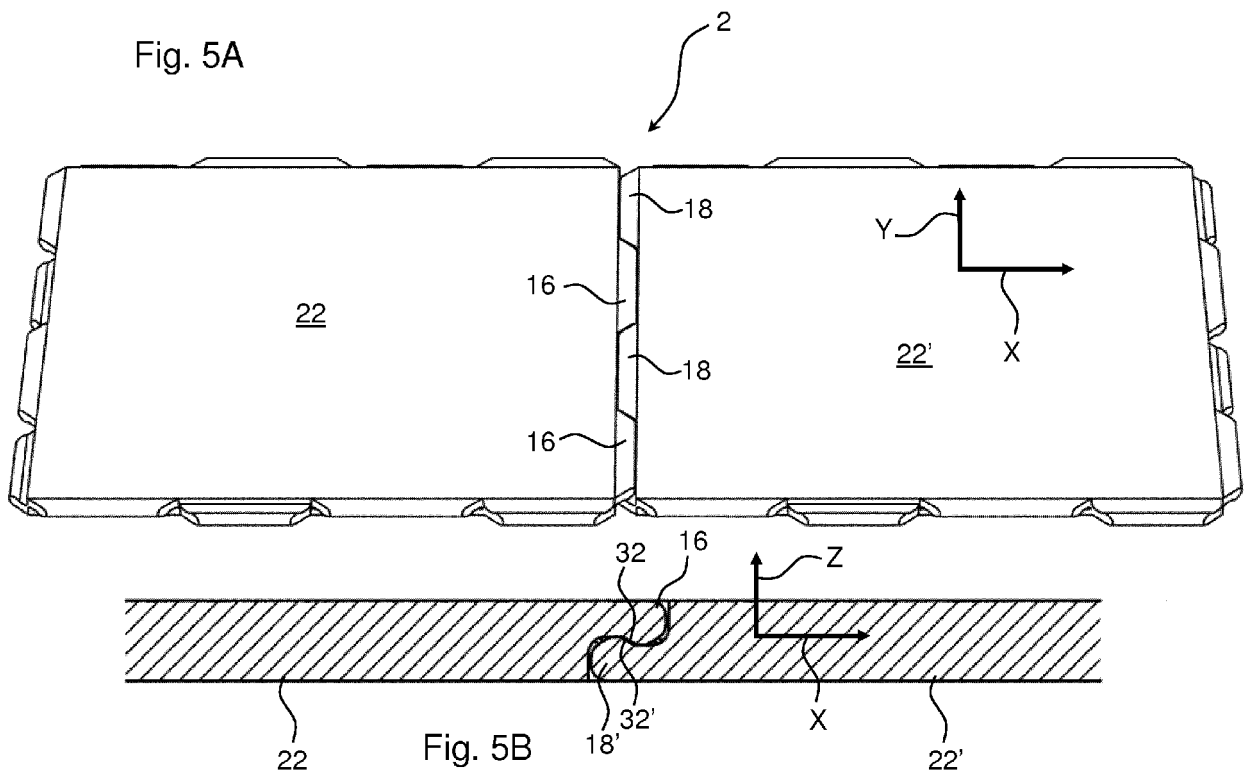

Fig. 6A

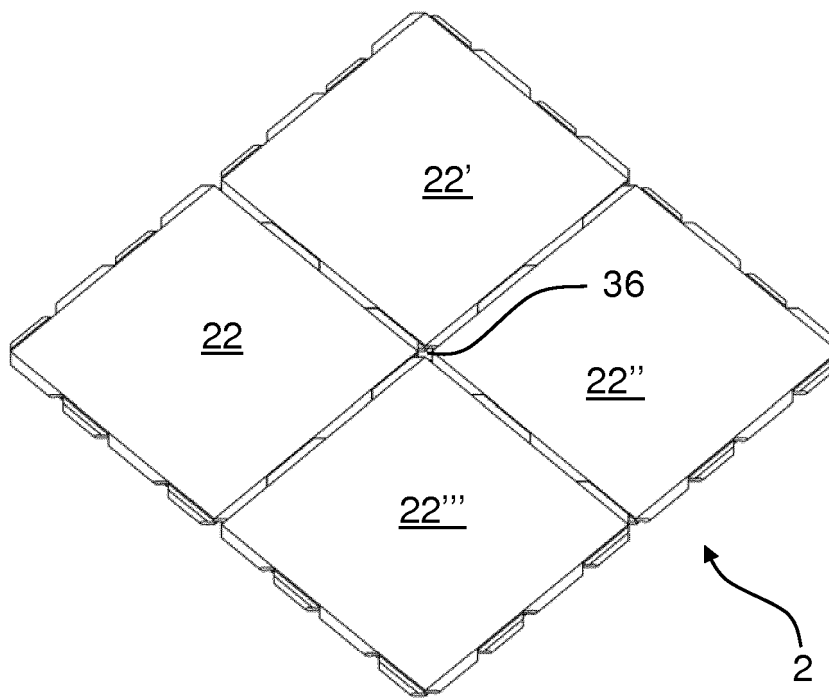
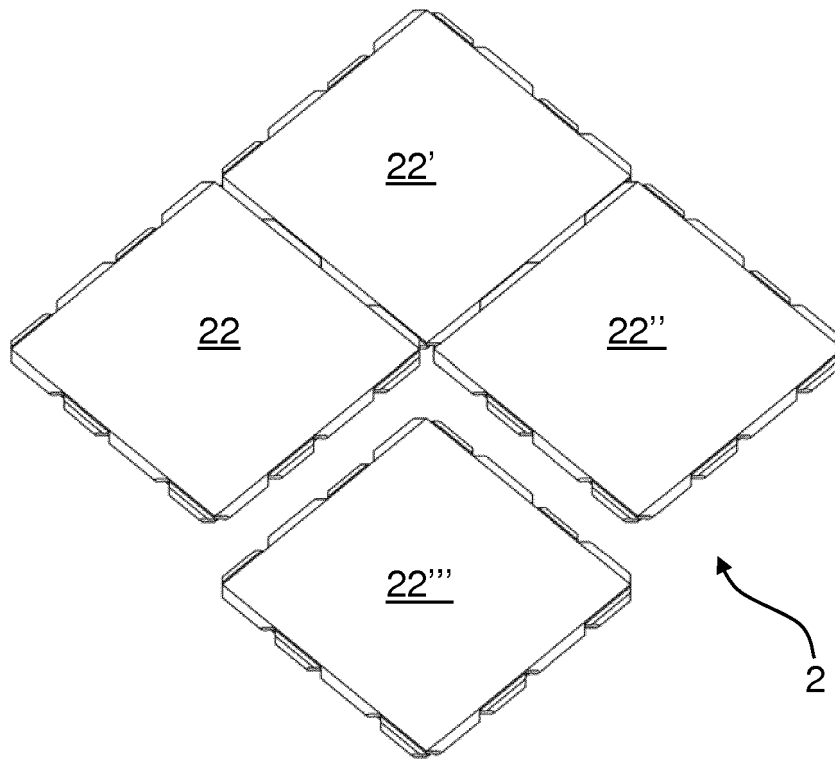

Fig. 6B

Fig. 7A

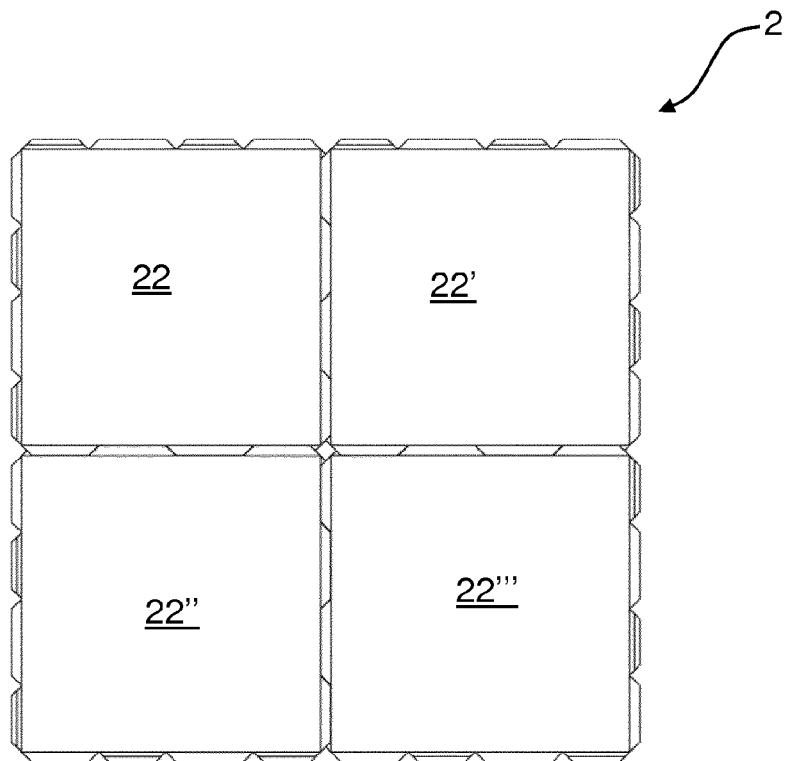
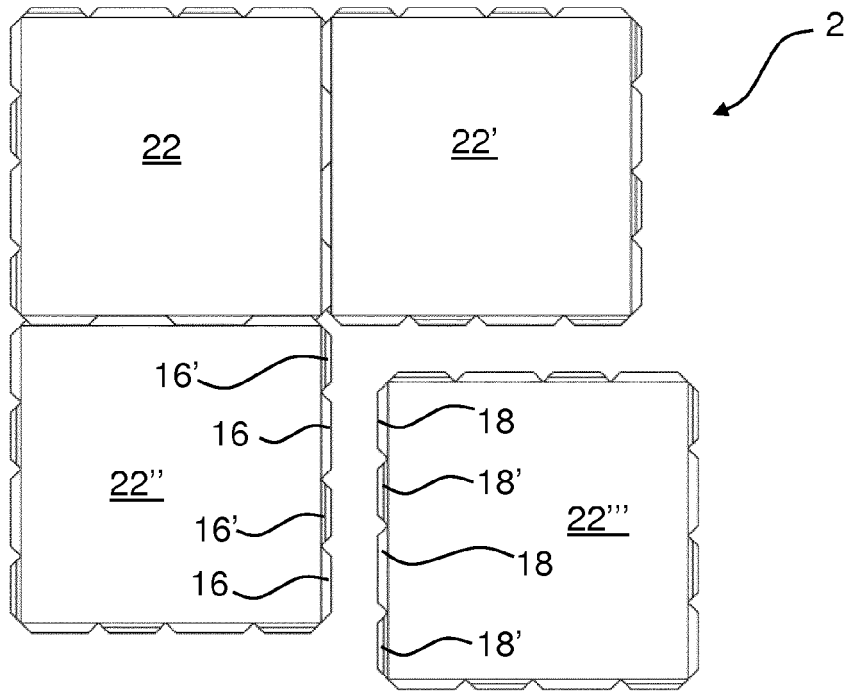
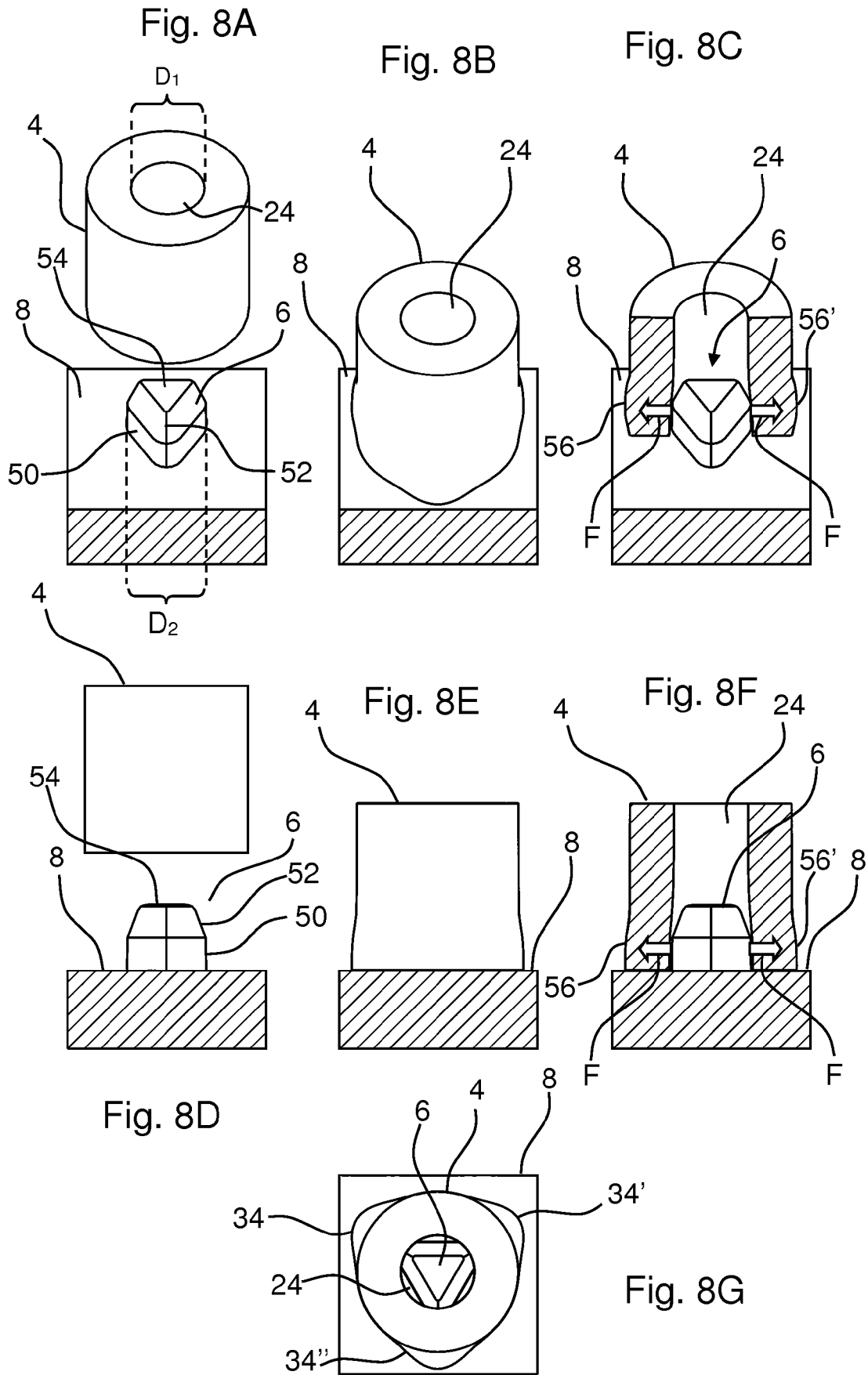

Fig. 7B



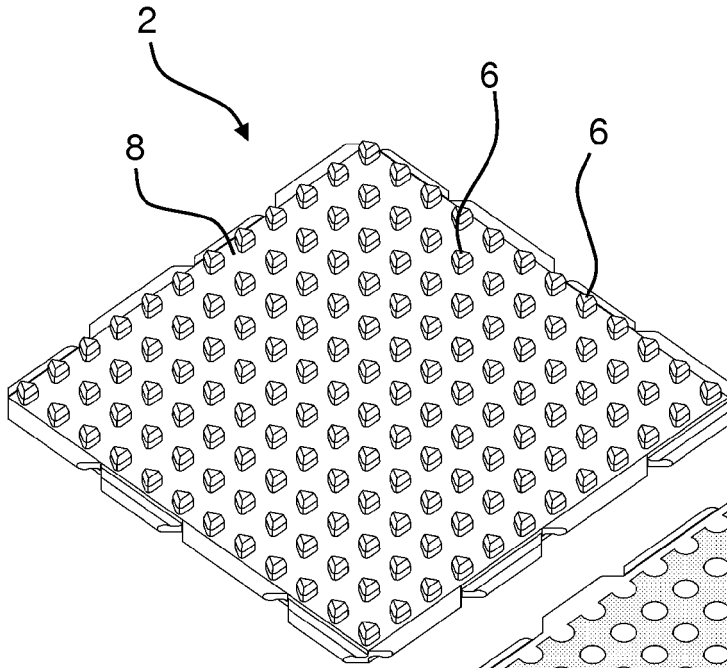

Fig. 9A

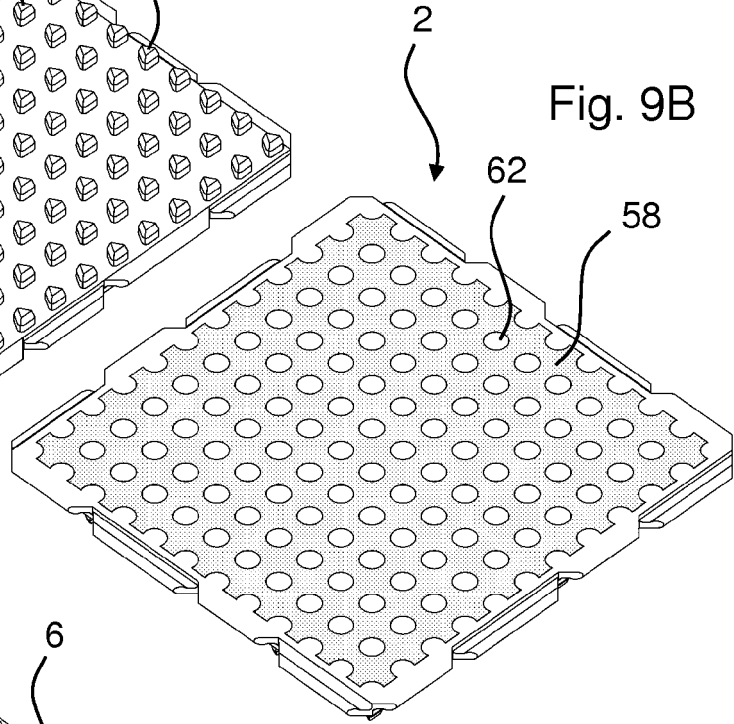

Fig. 9B

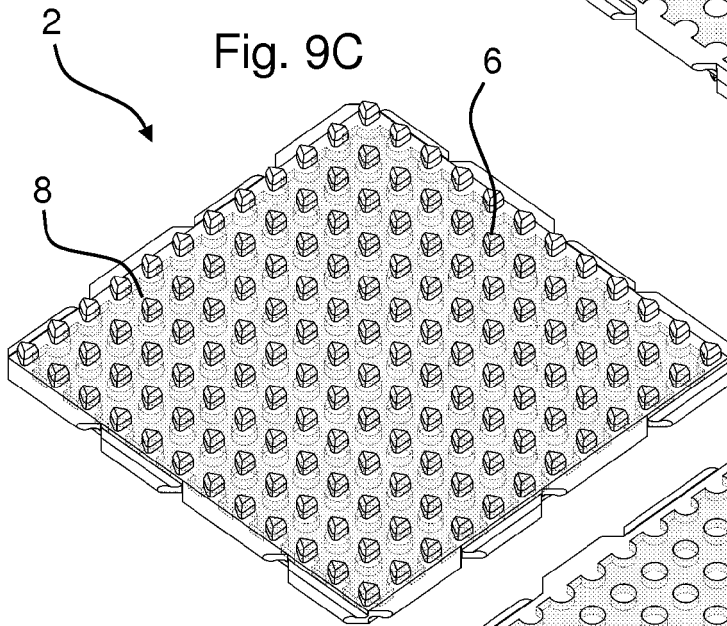

Fig. 9C

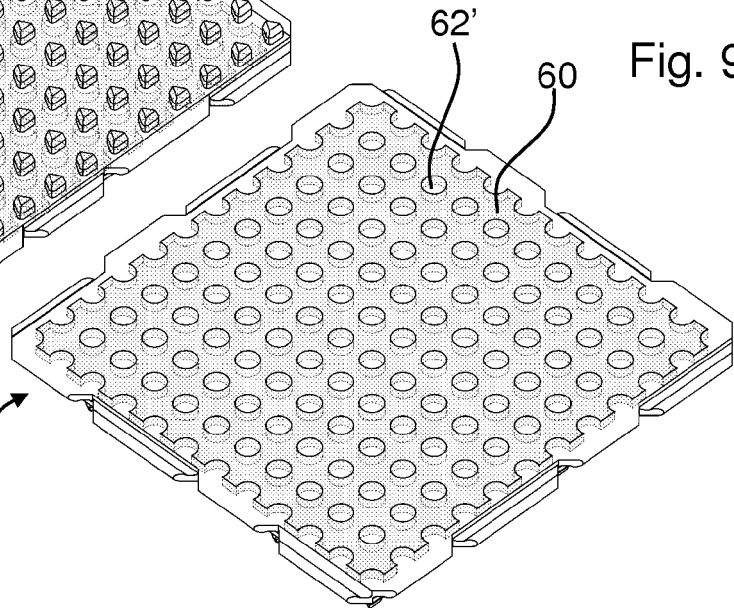
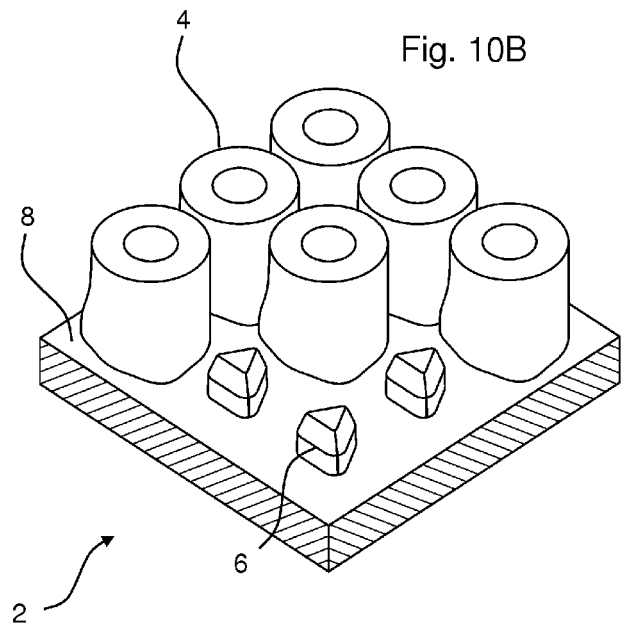
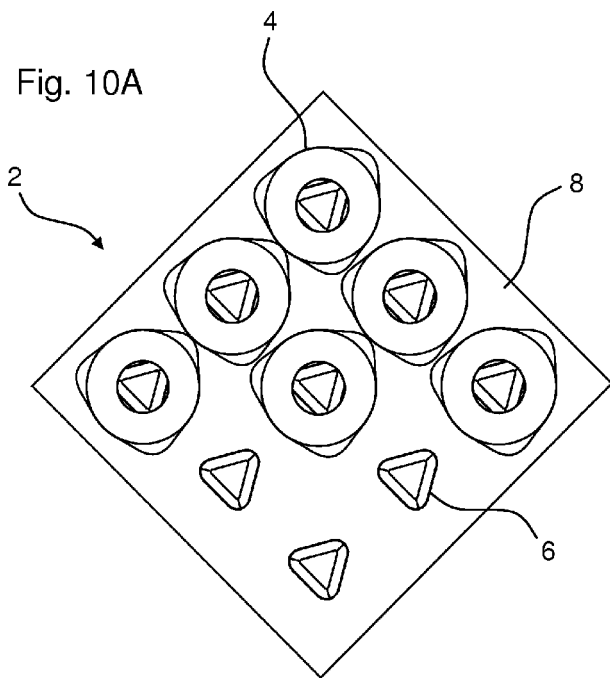

Fig. 9D



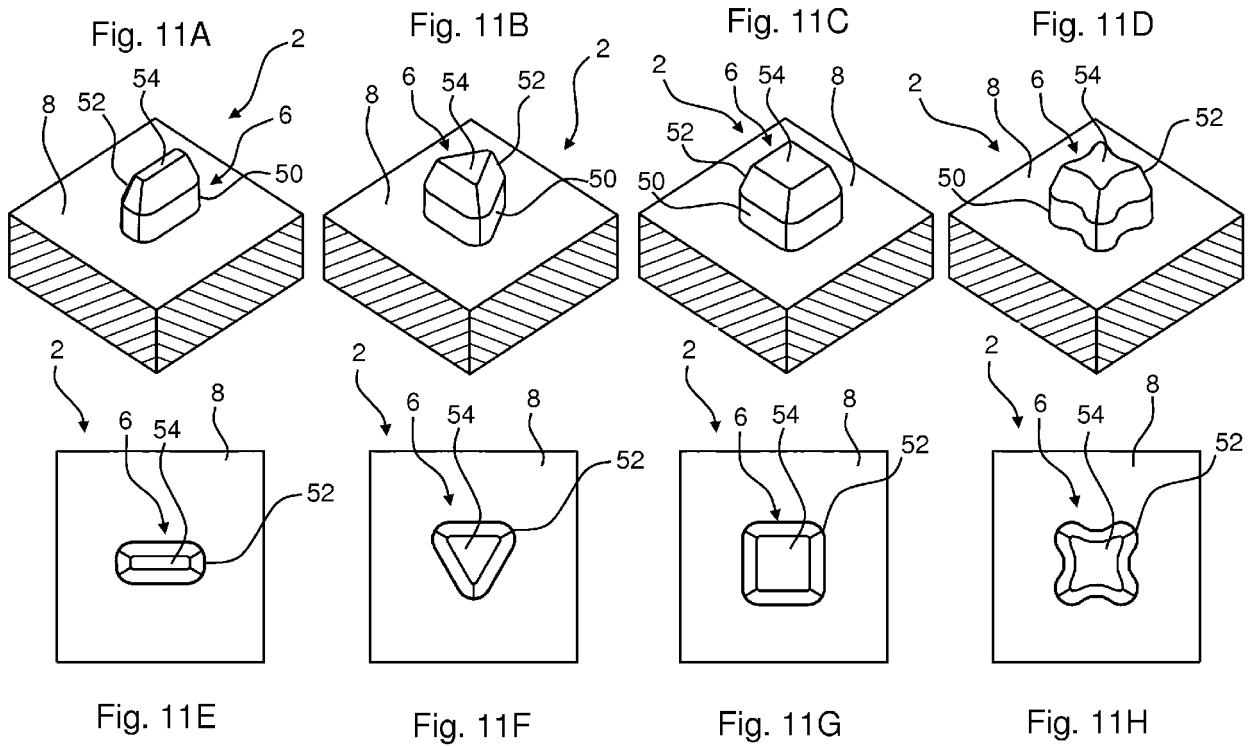

Fig. 12A

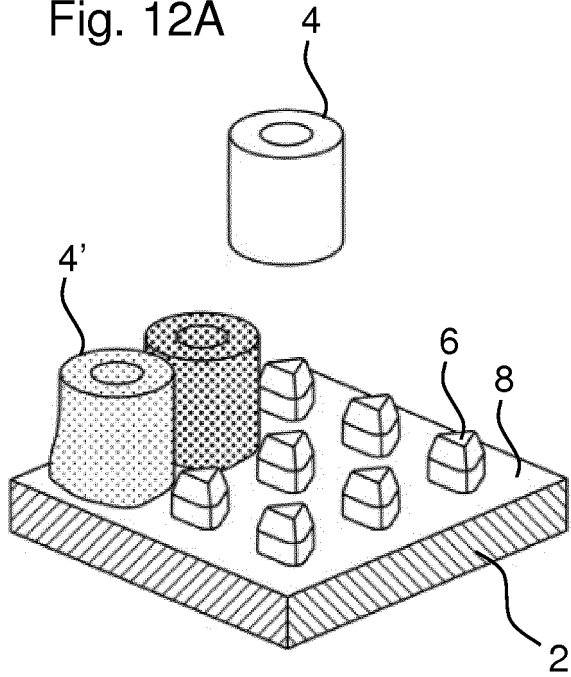

Fig. 12B

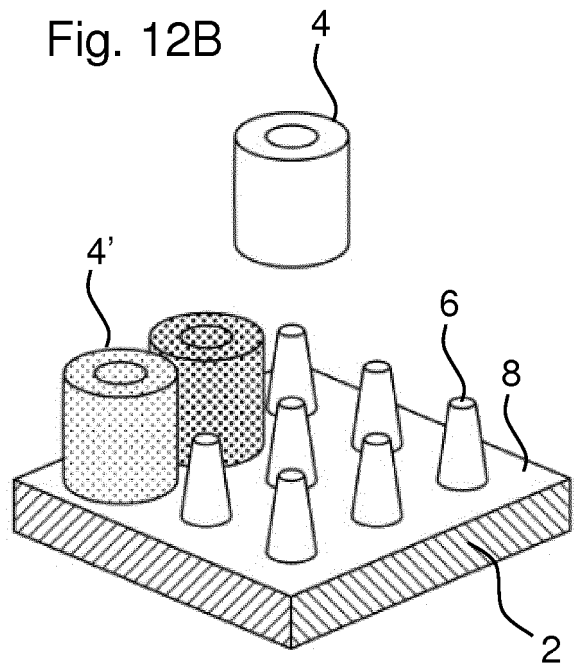

Fig. 12C

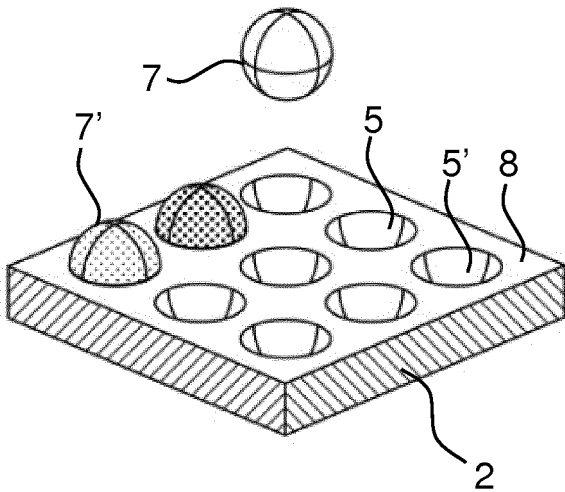

Fig. 12D

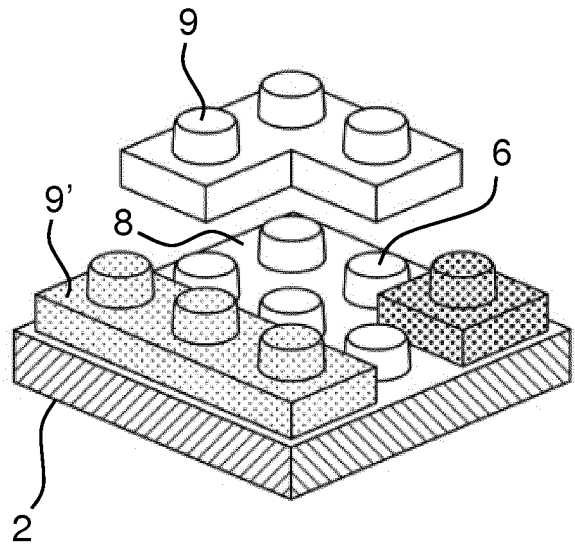

Fig. 13A

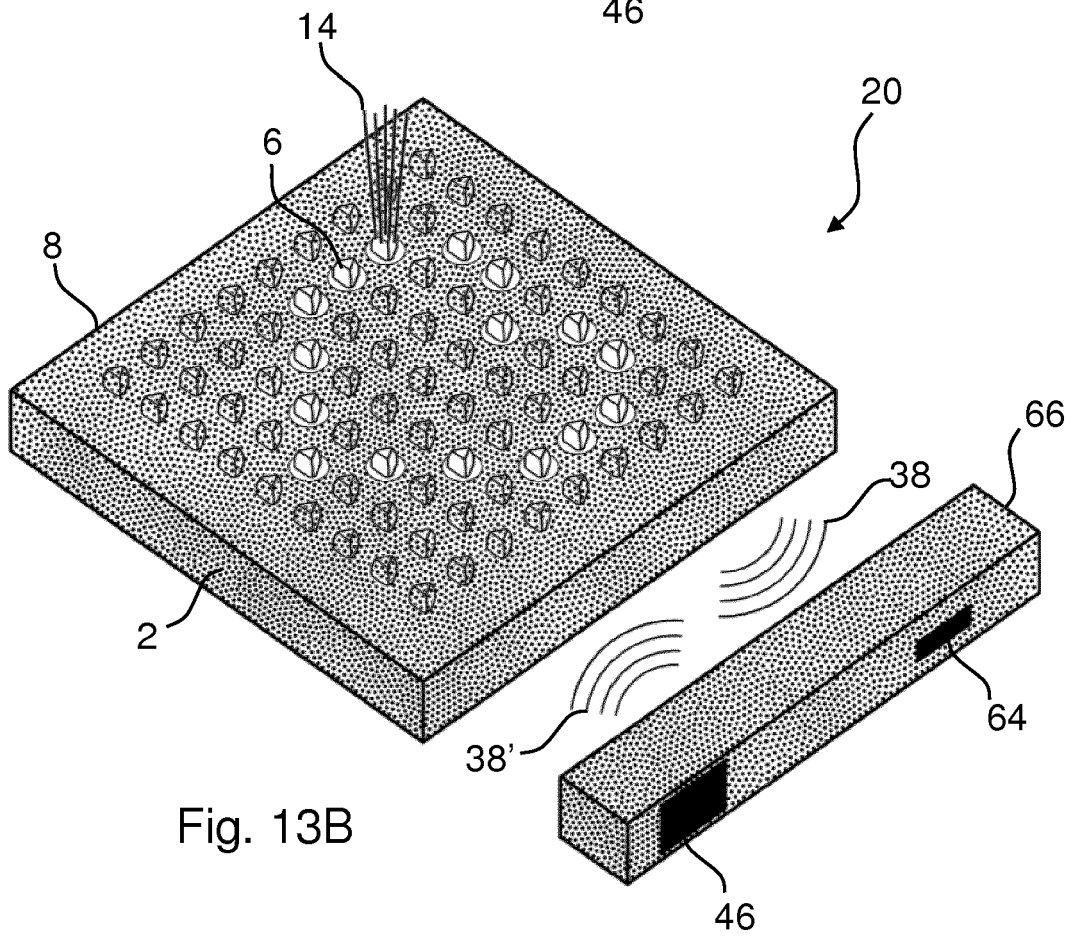
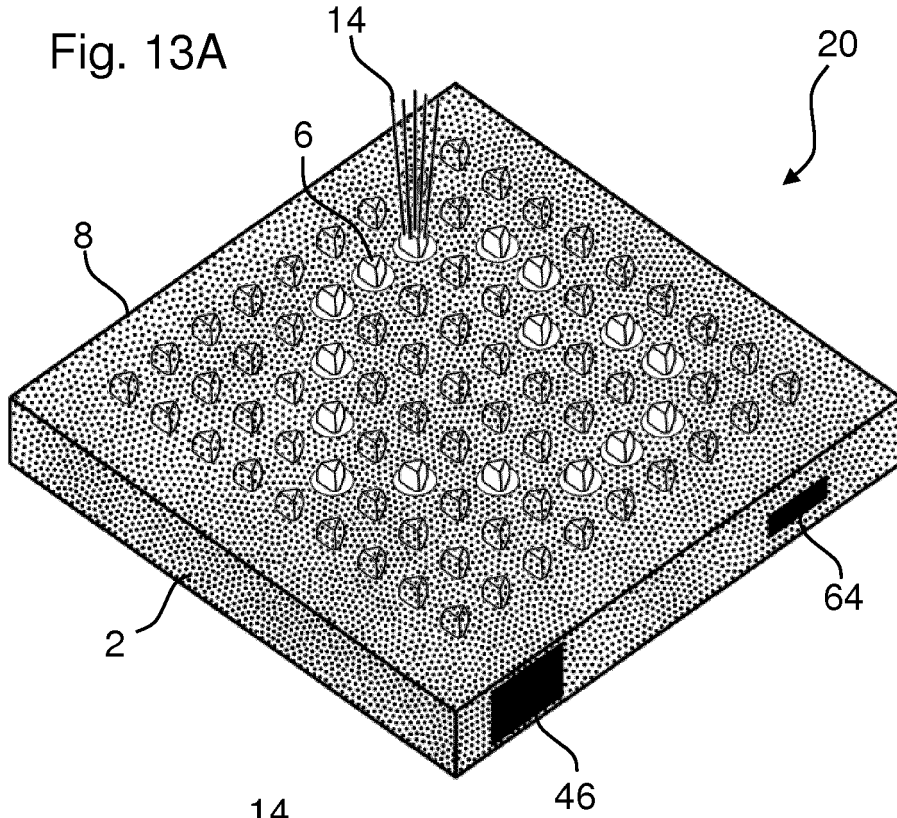

Fig. 13B

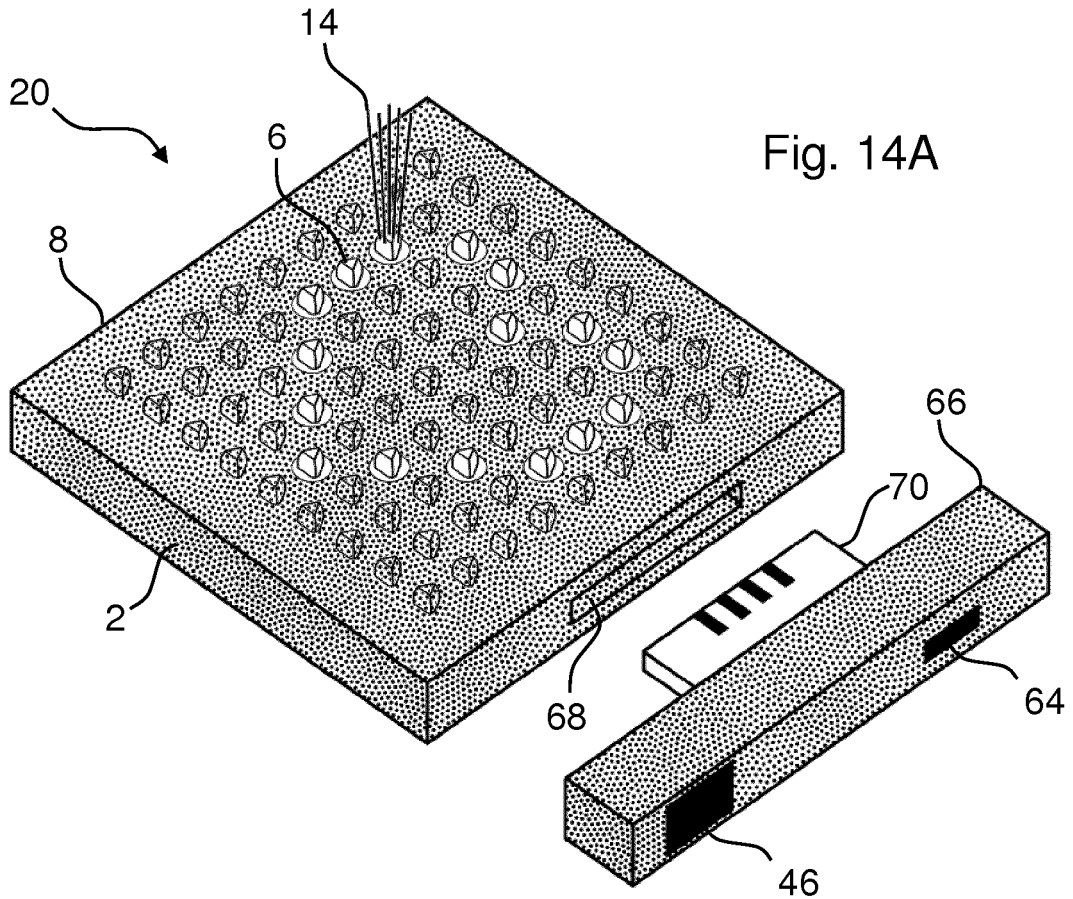

Fig. 14A

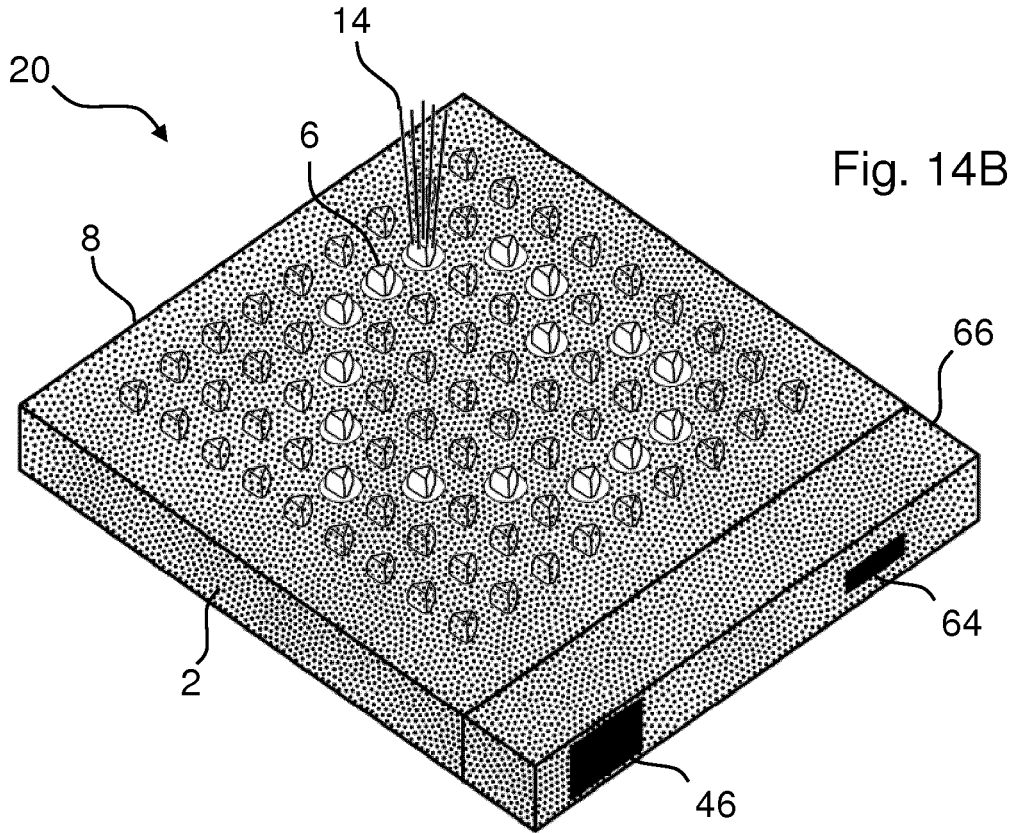

Fig. 14B

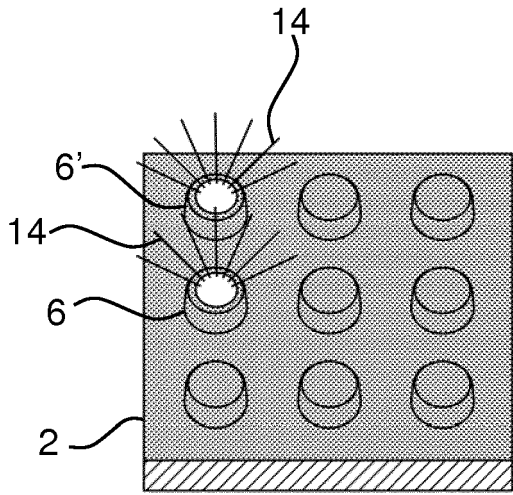

Fig. 15A

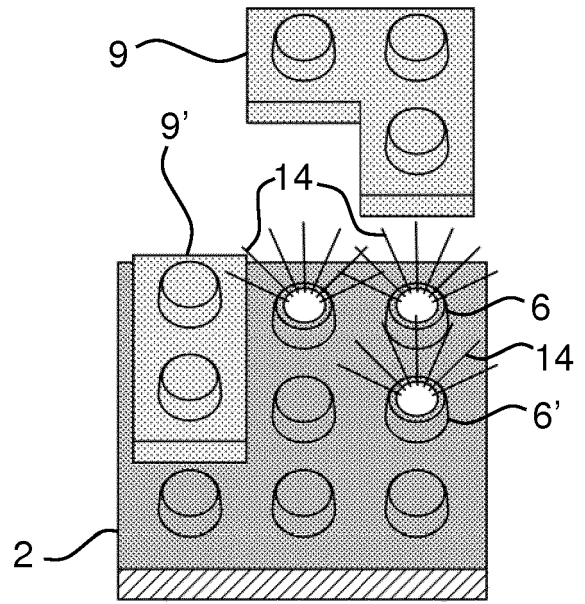

Fig. 15B

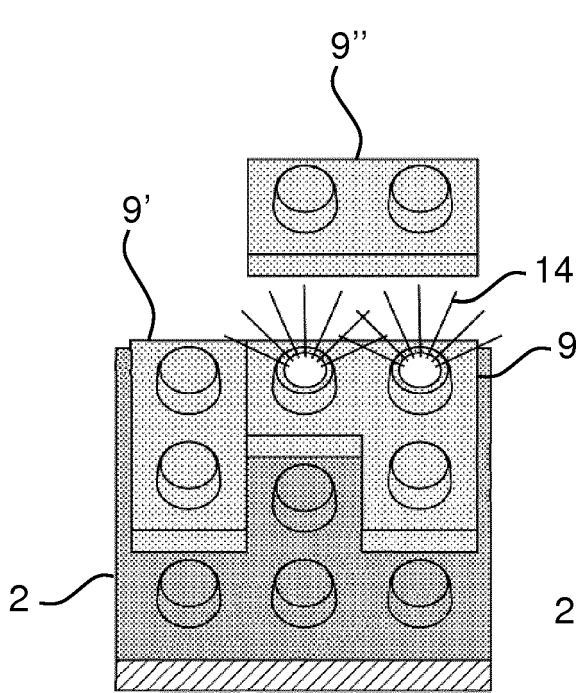

Fig. 15C

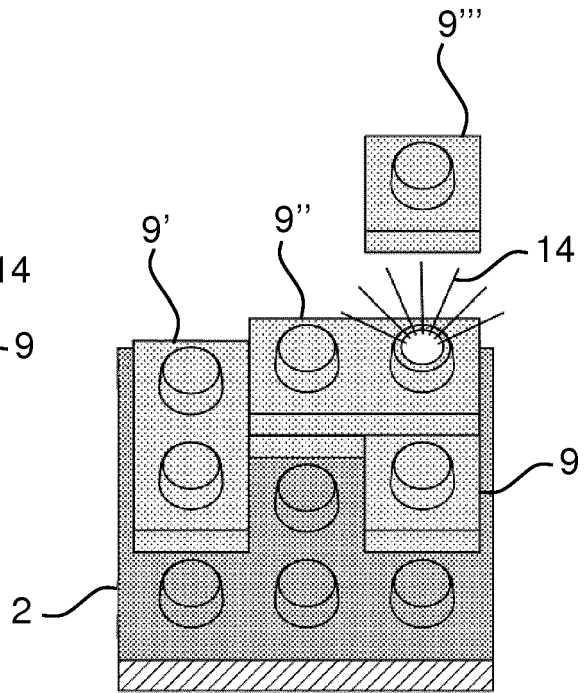

Fig. 15D

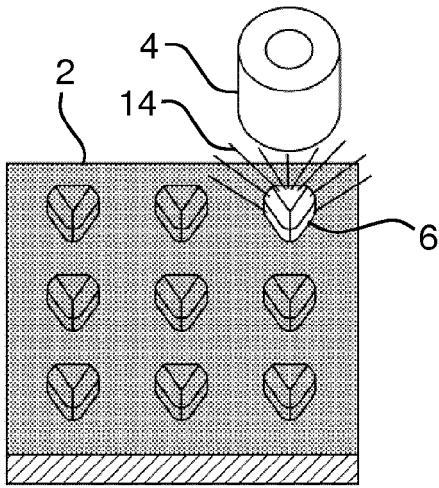

Fig. 16A

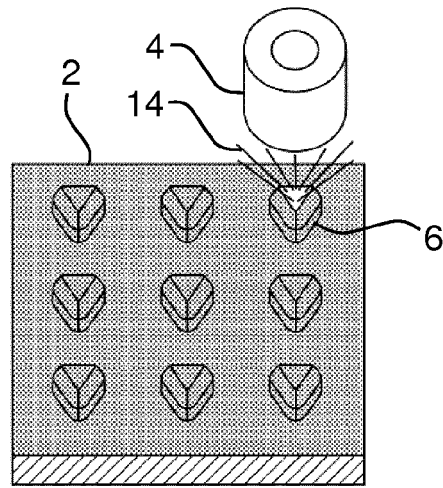

Fig. 16B

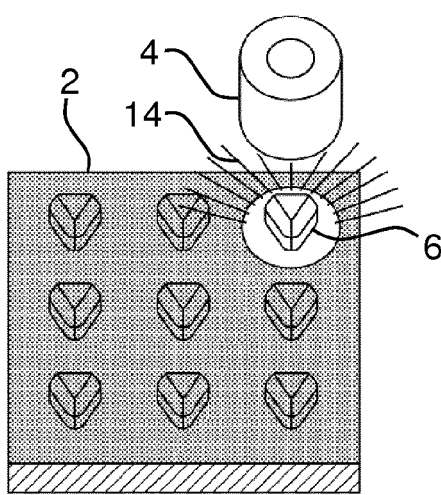

Fig. 16C

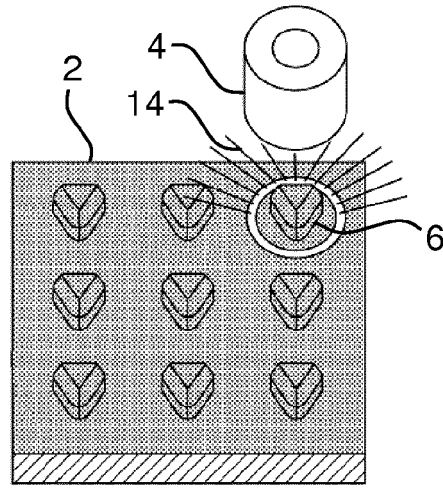

Fig. 16D

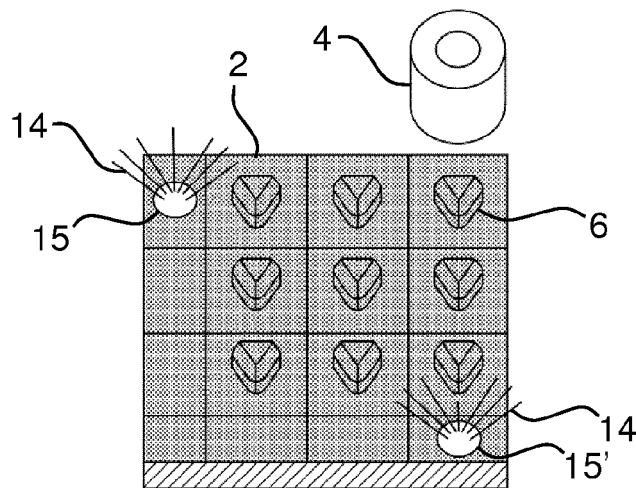

Fig. 16E



EUROPEAN SEARCH REPORT

Application Number  
EP 18 16 5749

5

10

15

20

25

30

35

40

45

50

55

DOCUMENTS CONSIDERED TO BE RELEVANT			
Category	Citation of document with indication, where appropriate, of relevant passages	Relevant to claim	CLASSIFICATION OF THE APPLICATION (IPC)
X	US 2014/120501 A1 (COOKE CORY [US] ET AL) 1 May 2014 (2014-05-01) * paragraph [0006] - paragraph [0013] * * paragraph [0055] - paragraph [0068]; figures 1-3,8-10,12 *	1-14	INV. A63H33/04 A63H33/08 A63H33/22
X	US 2016/271509 A1 (ARBOLEDA EDWIN N [US]) 22 September 2016 (2016-09-22) * paragraph [0028] - paragraph [0052]; figures 1-16 *	1-14	
			TECHNICAL FIELDS SEARCHED (IPC)
			A63H
The present search report has been drawn up for all claims			
Place of search The Hague		Date of completion of the search 3 October 2018	Examiner Melhem, Charbel
CATEGORY OF CITED DOCUMENTS X : particularly relevant if taken alone Y : particularly relevant if combined with another document of the same category A : technological background O : non-written disclosure P : intermediate document		T : theory or principle underlying the invention E : earlier patent document, but published on, or after the filing date D : document cited in the application L : document cited for other reasons ..... & : member of the same patent family, corresponding document	

EPO FORM 1503 03/02 (P04/C01)

**ANNEX TO THE EUROPEAN SEARCH REPORT  
ON EUROPEAN PATENT APPLICATION NO.**

EP 18 16 5749

5 This annex lists the patent family members relating to the patent documents cited in the above-mentioned European search report.  
The members are as contained in the European Patent Office EDP file on  
The European Patent Office is in no way liable for these particulars which are merely given for the purpose of information.

03-10-2018

10	Patent document cited in search report	Publication date	Patent family member(s)	Publication date
15	US 2014120501 A1	01-05-2014	EP 2914353 A1	09-09-2015
			JP 2016506250 A	03-03-2016
			KR 20150079663 A	08-07-2015
			US 2014120501 A1	01-05-2014
			WO 2014070743 A1	08-05-2014
20	----- US 2016271509 A1	22-09-2016	NONE	-----
25				
30				
35				
40				
45				
50				
55				

EPO FORM P0459

For more details about this annex : see Official Journal of the European Patent Office, No. 12/82