

(19)



(11)

EP 3 566 971 B1

(12)

EUROPEAN PATENT SPECIFICATION

(45) Date of publication and mention of the grant of the patent:
18.08.2021 Bulletin 2021/33

(51) Int Cl.:
B65D 43/02 (2006.01) B65D 51/22 (2006.01)

(21) Application number: **18380003.6**

(22) Date of filing: **08.05.2018**

(54) A CAP FOR A CONTAINER FOR LIQUIDS

DECKEL FÜR EINEN BEHÄLTER FÜR FLÜSSIGKEITEN

COUVERCLE D'UN RÉCIPIENT POUR LIQUIDES

(84) Designated Contracting States:
AL AT BE BG CH CY CZ DE DK EE ES FI FR GB GR HR HU IE IS IT LI LT LU LV MC MK MT NL NO PL PT RO RS SE SI SK SM TR

(43) Date of publication of application:
13.11.2019 Bulletin 2019/46

(73) Proprietor: **ITC Packaging, S.L.U.**
03440 Ibi (Alicante) (ES)

(72) Inventor: **Sánchez, Pedro Galera**
03440 Ibi Alicante (ES)

(74) Representative: **Ballester Cañizares, Rosalia**
Ballester Intellectual Property SLP
Avda. de la Constitución 16, 1^o D
03002 Alicante (ES)

(56) References cited:
US-A- 4 795 043 US-A1- 2009 301 988
US-A1- 2016 325 893

EP 3 566 971 B1

Note: Within nine months of the publication of the mention of the grant of the European patent in the European Patent Bulletin, any person may give notice to the European Patent Office of opposition to that patent, in accordance with the Implementing Regulations. Notice of opposition shall not be deemed to have been filed until the opposition fee has been paid. (Art. 99(1) European Patent Convention).

Description

Technical field

[0001] The invention relates to a cap for a sealed packaging container, in particular, a container for liquids, preferably beverages.

Prior art

[0002] Yoghurt is a milk-based product which is eaten by using a spoon, or is drunk. Drinkable yoghurts, as well as various beverages, are generally sold in containers such as small plastic bottles comprising a neck, sealed with a threaded cap. The seal or cap shall be removed by a user to drink the contents of the bottle.

[0003] However, in general, the act of removing the cap is not very practical since the cap is attached to a rim of the container, and the liquid inside might get spilt when the cap is removed. This operation may be even more critical if a container has a larger opening, if the container is a cup, for example.

[0004] Instead of removing the cap or lid, in the prior art it proposes perforating it to drink through the perforation created. Thus, the beverage may be easily transported, at the same time facilitating its consumption anywhere and in any circumstance, including while walking or when only one hand is free.

[0005] In the prior art is found document ES 1079052, which describes a flat accessory with a perforation funnel which may be applied to a container to perforate it. An orifice in the accessory enables the liquid to be drunk through the perforation created as a consequence in the cap. The accessory thus described is efficient, but presents some problems: firstly, it must be manually placed on the cap and secondly, it must be carefully handled by the user, which is detrimental to the handling of the product.

[0006] Documents JP2004123155 and JP2003327266 describe two accessories for containers, wherein each one presents a moving part with a cutting edge. These accessories must be safely coupled to the container before using the cutting edge, which improves its reliability. However, these accessories still require manual handling, which is impractical, these accessories being complex, bulky and expensive to manufacture.

[0007] One of the defects displayed by the known accessories is that they may create excessively large openings in the container which may lead to the beverage being spilt if not handled with the required precaution.

[0008] Document WO2015/101655 describes a cap for a container which has a larger surface area and which includes a body adapted to be attached to an upper surface of the container and a moving perforation platform which has at least one protruding perforator, the perforation platform is pushed with respect to the body from a resting position to a working position, wherein the perforating element perforates the upper surface of the con-

tainer. The particularity of this document is that the aforementioned perforation platform presents a first orientation in the resting position and a second orientation in the working position, wherein the first and second orientations differ by an angle of less than 30°.

[0009] On the other hand, document EP2675719 describes a container which has a lower part and a cap which covers the lower part, wherein the cap has a closure which can be moved from a first position to, at least, one additional position and which is characterised in that the lower part is completely enclosed by a cover and the closure is designed so that at least one opening is made in the cover when the closure is moved from a first position to a second position.

[0010] The two documents (WO'655 and EP'719) comprise an axis upon which the cap pivots at the same time as piercing the internal cover of the container protecting the liquid. Notwithstanding, this solution has two problems: (a) the cap must be perfectly centred on the container and no gaps should exist for the pivoting action to be effective; and (b) wherein the flange of the cap rotates on an angle from 30° to -2° -approximately- in some cases the user's finger ends up inside.

[0011] The document US2009301988A1 discloses a vessel cap according to the preamble of claim 1, that comprises a body mounted at a vessel inlet through which a liquid material stored in a vessel is discharged outwardly and having a certain space therein, a pressing plate disposed in the body to be movable in upper and lower directions, a cutter formed at an edge of a lower surface of the pressing plate in a circumferential direction for penetrating a sealing member when the pressing plate is pressed and cutting the sealing member when the body is rotated, a hooking member downwardly protruding at the lower surface of the pressing plate for storing the sealing member cut by the cutter in the body, and a connection portion formed between an outer circumferential surface of the pressing plate and an inner circumferential surface of the body for guiding the pressing plate to be moved in upper and lower directions. When the vessel cap is opened, the sealing member is automatically removed by a sealing member removing unit integrally formed at the vessel cap. Accordingly, a user's convenience is enhanced without additionally removing the sealing member. Furthermore, the vessel cap is manufactured by a single molding thereby to reduce a production cost.

[0012] The document US2016325893A1 a topper for a container having an upper surface, the topper including: a body adapted to engage an upper surface of the container, and a movable perforation platform having at least one protruding perforating element, the perforation platform being movable with respect to the body between: a resting position, and a working position wherein the perforating element perforates the upper surface of the container, wherein the perforation platform is held in the resting position by at least one breakable portion connecting the perforation platform to the body.

Explanation of the invention

[0013] An object of the invention is a cap for a container for liquids that is simpler, cheaper and more manageable while enabling good control of the perforation; all of which in order to solve the technical problems indicated in the prior art. This object is achieved with the cap of claim 1. Particular or preferred embodiments of the cap are described in dependent claims.

[0014] More specifically, the cap of the invention is subject to being incorporated in a container for liquids with an open upper surface and includes: (a) a body configured to be attached to the upper surface of the container, and (b) a perforation platform comprising a protruding perforating element, so that the perforation platform is pushed with respect to the body from a resting position to a working position, wherein the perforating element perforates the upper surface of the container.

[0015] The perforation platform has the particularity that, in the resting position, the platform is horizontally aligned with the upper surface of the body of the cap, while in the working position, the perforation platform moves vertically and, in its entirety, a distance so that the protruding perforating elements penetrate the upper surface of the container while they are in the working position and the perforation platform remaining in a parallel position to the upper surface of the cap.

[0016] The preferred non-limiting characteristics of the invention are: The body includes an upper part and an apron, wherein the apron is adapted to be attached to the upper surface of the container and the perforation platform forms part of the upper part of the body of the cap.

[0017] The perforation platform connects to the upper part by means of two articulated arms facing each other; and wherein said arms form part of the upper part of the cap.

[0018] The perforation platform, furthermore, comprises at least one orifice which cooperates with the perforating element when the perforating element perforates the upper surface of the container. Preferably, the perforation platform comprises two perforating elements and two corresponding orifices.

[0019] Throughout the description and the claims, use of the word «comprise» and its variants is not intended to exclude other technical characteristics, additives, components or steps. For those skilled in the art, other objects, benefits and characteristics of the invention shall emanate partly from the invention and partly from using the invention. The following examples and drawings are provided by means of illustration and are not intended to restrict this invention.

Brief description of the drawings

[0020] Below, a series of drawings which help to understand the invention better, which relate expressly to one embodiment of said invention and which illustrate a

non-limiting example of it, are very briefly described.

FIG.1 shows a schematic view of a transverse section of an assembly of a container and a cap according to this invention.

FIG.2 shows a view of the cap in the resting position. FIG.3 shows a view of a cross-section of the cap of FIG.2 .

FIG.4 shows a view of the cap in the working position.

FIG.5 shows a view of a cross-section of the cap of FIG.4

Detailed explanation of one embodiment of the invention and examples

[0021] With reference to the enclosed figures, this invention proposes a cap 2 for a container 1 which has an upper surface 10.

[0022] The container 1 is, for example, a substantially cylindrical (and/or conical) hollow part made from glass, cardboard or plastic, in particular, polystyrene (PS), polypropylene (PP), polyethylene (PE), polylactic acid (PLA). As shall be described throughout this description, the upper surface 10 preferably includes a lid which seals the container 1, wherein the lid is manufactured of, by way of non-limiting examples, aluminium, paper, plastic or a combination of these.

[0023] The container 1 may have the form of a cup for drinking from or the form of a pot for yoghurt. The container 1 may thus comprise an opening, which must be covered by means of the upper surface 10, a base and lateral walls. The opening and/or lateral walls may have, horizontally, a squared transverse section or a square with a transverse section with rounded corners, or a rounded transverse section or an oval transverse section. The walls may be cylindrical or conical in shape. The walls (perpendicular to the transverse section) may be provided with elements such as adhesive labels or banners. The banners may help to reinforce the mechanical resistance of the container 1.

[0024] The container 1 may be filled with a liquid, preferably a milk-based formula. The liquid in container 1 may be any liquid, for example an edible or drinkable liquid, often referred to as liquid foods. It may be, for example, a sauce, a soup or a beverage: here, beverages include water, juices, fizzy drinks, milk-based formulae such as milk, which may be flavoured, and fermented lactic products, for example, yoghurt or kefir.

[0025] The container 1 may be of any size, volume or capacity, for example, a container from 50 ml (or 50 g), to 1L (or 1 kg) in any possible combination. It should be understood that someone skilled in the art will know how to adapt the cap according to the invention to any container 1 which has an upper surface 10.

[0026] The cap 2 is, for example, a part which sits on top of the container 1. It may be made of a similar or a different material than the container 1, for example, polystyrene (PS), polypropylene (PP), polyethylene (PE),

polylactic acid (PLA). In a particular, non-limiting embodiment, PP is the preferred manufacturing material, since it presents good flexibility and resistance to breakages. In other words, the cap 2 includes a body adapted to be attached firmly and securely to the upper surface 10 of the container 1.

[0027] As can be seen in the enclosed figures, the body of the cap 2 includes a cap 2a and an apron 2b, wherein the apron 2b is applied to the upper surface 10 of the container 1. The cap 2a may be a flat part, and the apron 2b may have a cylindrical shape. Thus, an inverse transverse section of the cap 2 is «U»-shaped.

[0028] The upper surface 10 is attached to the container 1 perimetrically. In other words, it is understood that it cooperates with the perimeter edge of the upper surface 10 to assemble the container 1 and the cap 2.

[0029] Thus, as can best be seen in figure 1, the apron 2b includes at least one flap 21 which protrudes from the inner surface of the apron 2b and extends radially to the centre of the cap 2. This flap 21 cooperates with at least one flange 11 which protrudes from the edge of the container 1 (in other words, in the periphery of the upper surface 10), said flange 11 extends radially to the outside of the container 1. When the upper surface 10 of the container 1 is attached to the cap 2 due to a translatory movement of the container 1, the apron 2b is deformed (specifically, by means of an elastic deformation) until the flanges 11 of the container 1 straddle the flanges of the apron 2b, in order to attach the cap 2 to the container 1. When the apron is applied to the upper surface 10, the apron 2b defines an internal recess between the cap 2a and the container 1.

[0030] The cap 2 is fitted with a moving perforation platform 3 which has at least one protruding perforating element 4a, 4b. This perforation platform 3 is connected to the cap 2a.

[0031] The perforation platform includes at least one orifice 5a, 5b, preferably a main orifice 5a and an ancillary orifice 5b. The main orifice 5a is a drinking orifice, and the ancillary orifice 5b is a respiration orifice (which enables air to enter the container 1 to replace the liquid drunk).

[0032] The perforation platform 3 is mobile with respect to the upper part of the cap 2a between a resting position and a working position in which the perforation element 4a, 4b perforates the upper surface 10 of the container 1.

[0033] When the perforation platform 3 has two orifices 5a, 5b, the perforation platforms 3 have two corresponding perforating elements 4a, 4b. Each perforating element 4a, 4b cooperates with an orifice 5a, 5b to create an opening aligned with the orifice 5a, 5b in the upper surface 10 when it is perforated. In other words, when the perforation platform 3 is in the working position, it enables the connection of the fluid between the inside and the outside of the container 1 through the perforated upper surface 10 and the perforation platform 3 (through the orifices 5a, 5b). In particular, the perforating elements 4a and 4b may be sharpened parts of diverse shapes.

[0034] The perforation platform 3 is pushed, in other words, is displaced vertically and in parallel with respect to the upper part 2a of the cap 2 when pushed -with a finger, for example-from the resting position to the working position. «Push» is understood as to apply a force of pressure in the same direction of movement, in other words, from up to down, in vertical motion.

[0035] The perforation platform 3 is configured so that, in the resting position (figures 2 and 3) it presents a position horizontally aligned with the upper part 2a of the cap 2. In the working position (figures 4 and 5), however, it presents a second position, wherein the perforation platform 3 is displaced vertically and, in its entirety, a distance so that the protruding perforating elements 4a and 4b penetrate the upper surface 10 of the container 1, and the perforation platform 3 remaining in a substantially parallel position to the upper surface 2a of the cap.

[0036] In other words, the perforation platform 3 is configured so that the resting position and the working position are aligned or parallel to the upper surface 2a of the cap 2. Thus, the movement when changing from the resting position to the working position is purely translatory, and is not due to any rotation, as opposed to the documents quoted in the prior art which present rotations of between 30° and 90°, possibly leading to leakages or even problems with the introduction of the finger or the rotation axis of these perforating platforms breaking - particularly, in document WO2015/101655.

[0037] The perforation platform 3 does not penetrate the upper surface 10 of the container 1 when it is in the working position and, advantageously, only the protruding perforating elements 4a and 4b are enabled to penetrate the upper surface 10 of the container 1, so that the perforation platform 3 prevents leakages from the same.

[0038] The movement to change the position of the perforation platform 3 from the resting position to the working position is a vertical translation of the platform 3 while remaining in parallel with the upper part 2a of the cap 2 during said translatory movement. To this effect, two arms 7a and 7b, positioned facing each other, connect the perforation platform 3 with the upper part 2a of the cap 2 by means of, respectively, two joints 6a and 6a' for a first arm 7a and another two joints 6b and 6b' for a second arm 7b.

[0039] Thus, when a user exerts a vertical force on the platform 3, breakable portions 8 disposed in the perimeter of the platform 3 break and it moves downwards, at the same time as the facing arms 7a and 7b articulate from the resting position to the working position. To be precise, the joints of the arms 7a and 7b, which face each other, enable the platform 3 to remain in parallel with the upper part 2a of the cap 2, thus guaranteeing that leakages of the liquid contained in the container 1 cannot occur, delivering safer use and easier operation and manufacture.

Claims

1. A container (1) for liquids comprising a cap (2), wherein the cap (2) includes:

a body configured to be attached to an upper surface (10) of the container (1), and a perforation platform (3) comprising a plurality of protruding perforating elements (4a,4b), so that the perforation platform (3) is displaced vertically with respect to the cap body from a resting position to a working position, wherein the perforating elements (3) perforate the upper surface (10) of the container (1);

in the resting position, the perforation platform (3) is horizontally aligned with the upper surface (2a) of the cap body, while, in the working position, the perforation platform (3) is displaced vertically, and in its entirety, a distance so that the protruding perforating elements (4a,4b) exclusively penetrate the upper surface (10) of the container (1) and with the perforation platform (3) remaining in a parallel position to the upper surface (2a) of the cap (2);

and which is **characterised in that** the perforation platform (3) also comprises a drinking orifice (5a) which cooperates with one of the protruding perforating elements when the protruding perforating element (4a) perforates the upper surface (10) of the container (1).

2. The container (1) of claim 1 wherein the cap body includes an upper part (2a) and an apron (2b), wherein the apron (2b) is adapted to attach to the upper surface (10) of the container (1) and the perforation platform (3) is part of the upper part of the cap body.
3. The container (1) according to claim 1 wherein the perforation platform (3) is connected to the upper part (2a) of the cap (2) by means of two articulated arms (7a,7b) which face each other; and wherein said arms are part of the upper part (2a) of the cap (2).
4. The container (1) according to claim 1 wherein the perforation platform (3) comprises two perforating elements (4a, 4b), and two corresponding orifices (5a, 5b), wherein the first orifice is the drinking orifice (5a), and the other perforating element (4b) corresponds with the second orifice (5b).

Patentansprüche

1. Ein Behälter (1) für Flüssigkeiten mit einer Kappe (2), worin die Kappe (2) umfasst:

einen Körper, der so konfiguriert ist, dass er an einer oberen Fläche (10) des Behälters (1) an-

gebracht werden kann, und

eine Perforationsplattform (3), die eine Vielzahl von vorstehenden Perforationselementen (4a, 4b) aufweist, sodass die Perforationsplattform (3) vertikal in Bezug auf den Kappenkörper von einer Ruheposition in eine Arbeitsposition verschoben wird, wobei die Perforationselemente (3) die obere Oberfläche des Behälters (1) perforieren;

in der Ruheposition die Perforationsplattform (3) horizontal mit der oberen Fläche (2a) des Kappenkörpers ausgerichtet ist, während in der Arbeitsposition die Perforationsplattform (3) vertikal und in ihrer Gesamtheit um eine Strecke verschoben ist, sodass die vorstehenden Perforationselemente (4a, 4b) ausschließlich die obere Fläche (10) des Behälters (1) durchdringen, und wobei die Perforationsplattform (3) in einer parallelen Position zur oberen Fläche (2a) der Kappe (2) verbleibt;

und die **dadurch gekennzeichnet ist, dass** die Perforationsplattform (3) auch eine Trinköffnung (5a) aufweist, die mit einem der vorstehenden Perforationselemente zusammenwirkt, wenn das vorstehende Perforationselement (4a) die obere Fläche (10) des Behälters (1) perforiert.

2. Behälter (1) nach Anspruch 1, wobei der Kappenkörper einen oberen Teil (2a) und eine Schürze (2b) umfasst, wobei die Schürze (2b) so angepasst ist, dass sie an der oberen Fläche (10) des Behälters (1) befestigt werden kann, und die Perforationsplattform (3) Teil des oberen Teils des Kappenkörpers ist.
3. Behälter (1) nach Anspruch 1, wobei die Perforationsplattform (3) mit dem oberen Teil (2a) der Kappe (2) mittels zweier gelenkiger Arme (7a, 7b) verbunden ist, die einander gegenüberliegen; und wobei die Arme Teil des oberen Teils (2a) der Kappe (2) sind.
4. Behälter (1) nach Anspruch 1, wobei die Perforationsplattform (3) zwei Perforationselemente (4a, 4b) und zwei entsprechende Öffnungen (5a, 5b) aufweist, wobei die erste Öffnung die Trinköffnung (5a) ist und das andere Perforationselement (4b) mit der zweiten Öffnung (5b) korrespondiert.

Revendications

1. Un récipient (1) pour liquides comprenant un couvercle (2), dans lequel le couvercle (2) comprend un corps configuré pour être fixé à une surface supérieure (10) du récipient (1), et une zone de perforation (3) comprenant une pluralité

d'éléments de perforation saillants (4a, 4b), de sorte que la zone de perforation (3) est déplacée verticalement par rapport au corps du couvercle d'une position de repos à une position de travail, dans laquelle les éléments de perforation (3) perforent la surface supérieure du récipient (1);

dans la position de repos, la zone de perforation (3) est alignée horizontalement avec la surface supérieure (2a) du corps du couvercle, tandis que, dans la position de travail, la zone de perforation (3) est déplacée verticalement, et dans sa totalité, d'une distance telle que les éléments de perforation saillants (4a, 4b) pénètrent exclusivement dans la surface supérieure (10) du récipient (1) et avec la zone de perforation (3) restant dans une position parallèle à la surface supérieure (2a) du couvercle (2); et qui est **caractérisée en raison du fait que** la zone de perforation (3) comprend également un orifice pour boire (5a) qui coopère avec l'un des éléments de perforation saillants lorsque l'élément de perforation saillant (4a) perce la surface supérieure (10) du récipient (1).

2. Le récipient (1) de la revendication 1, dans lequel le corps du bouchon comprend une partie supérieure (2a) et un rebord (2b), dans lequel le rebord (2b) est adapté pour être fixé à la surface supérieure (10) du récipient (1) et la zone de perforation (3) fait partie de la partie supérieure du corps du couvercle.
3. Le récipient (1) selon la revendication 1, dans lequel la zone de perforation (3) est reliée à la partie supérieure (2a) du couvercle (2) au moyen de deux bras articulés (7a, 7b) qui se font face ; et dans lequel lesdits bras font partie de la partie supérieure (2a) du couvercle (2).
4. Le récipient (1) selon la revendication 1, dans lequel la zone de perforation (3) comprend deux éléments de perforation (4a, 4b) et deux orifices correspondants (5a, 5b), dans lequel le premier orifice est l'orifice de boisson (5a), et l'autre élément de perforation (4b) correspond au second orifice (5b).

45

50

55

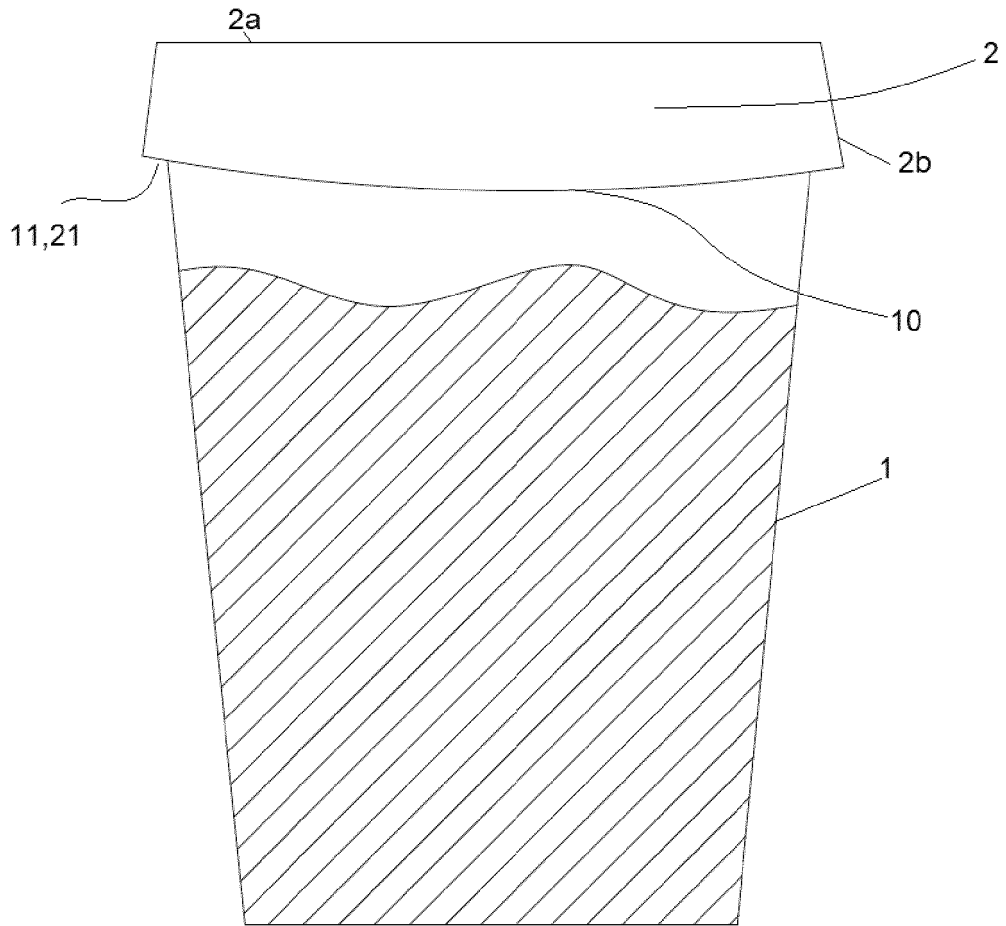
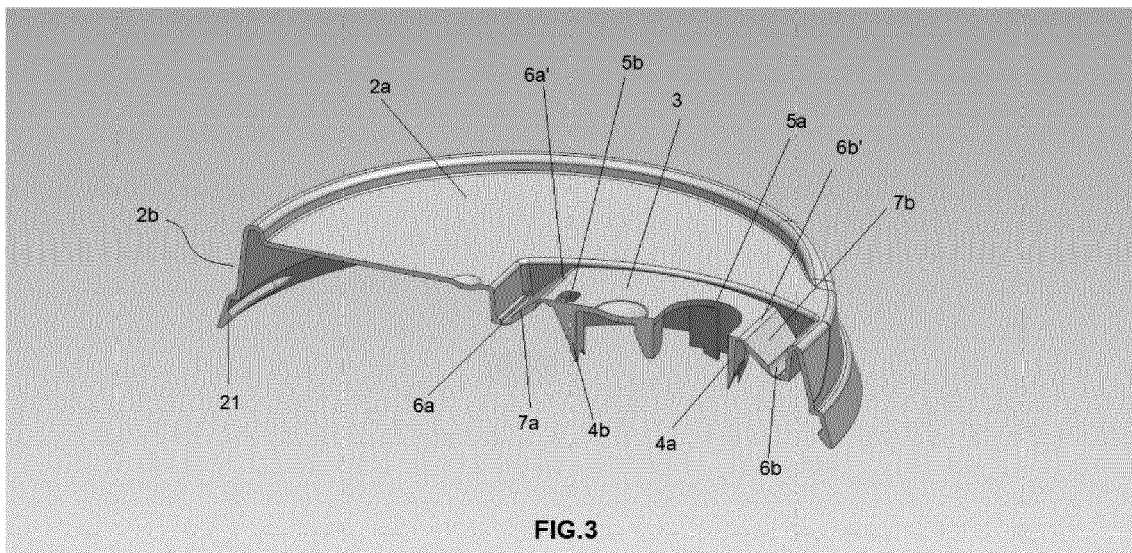
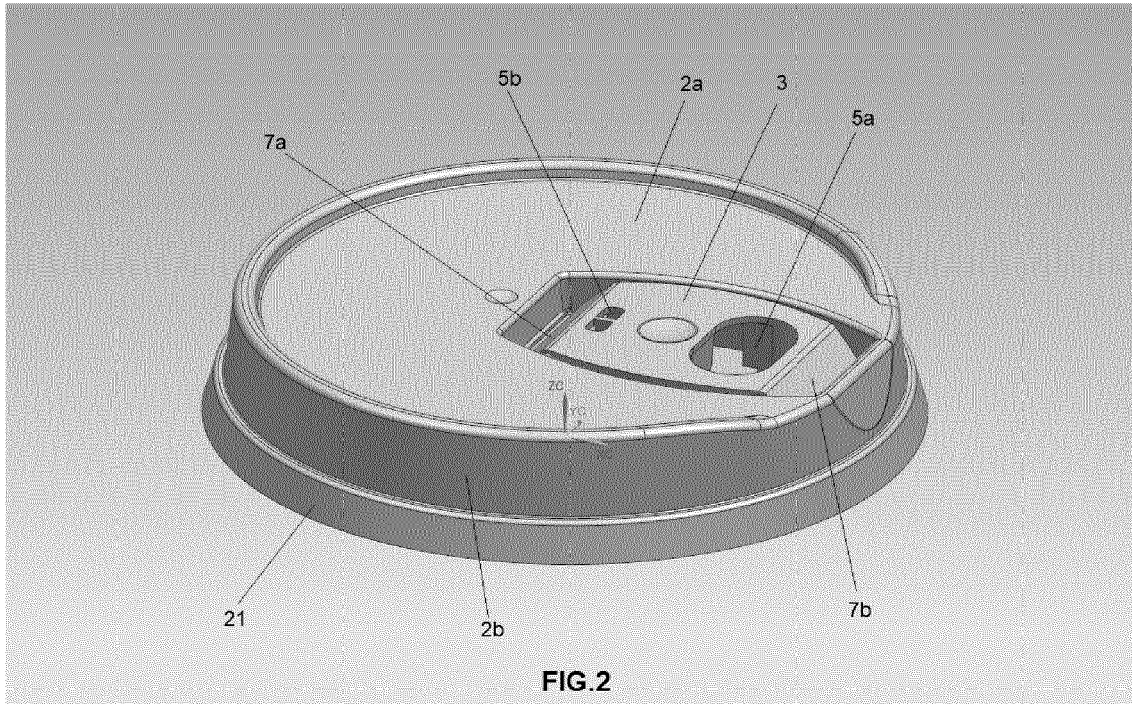
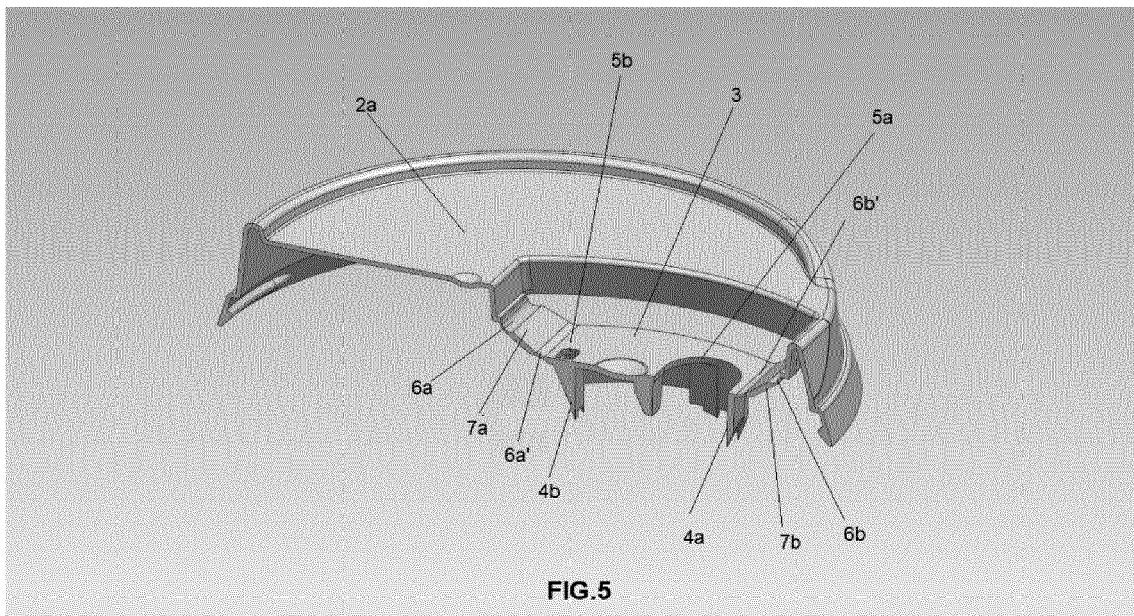
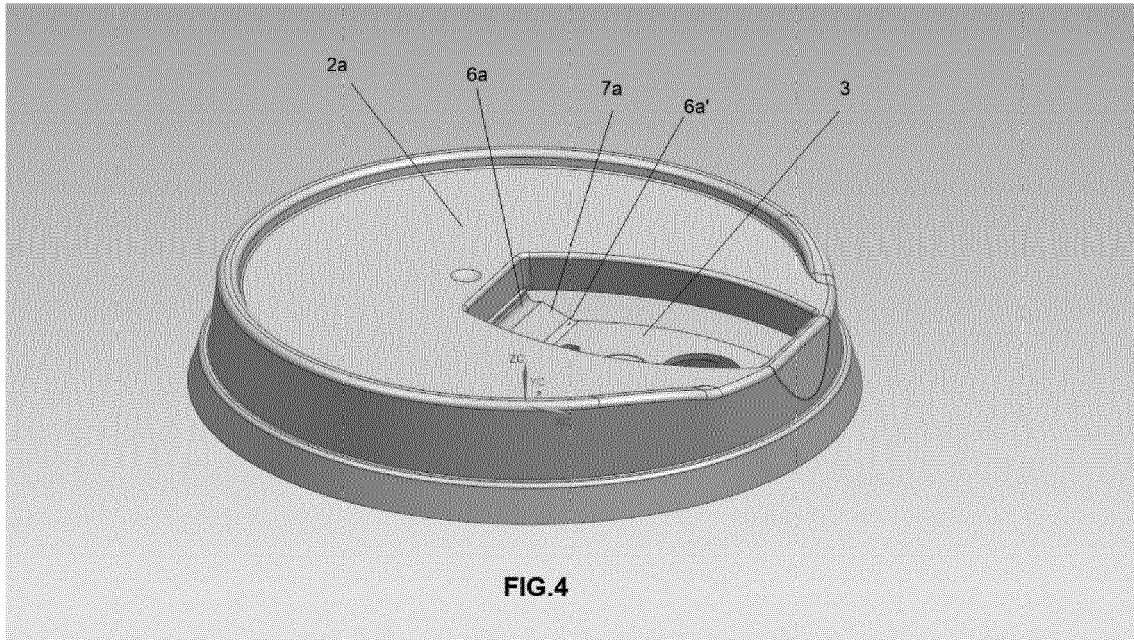

FIG.1





REFERENCES CITED IN THE DESCRIPTION

This list of references cited by the applicant is for the reader's convenience only. It does not form part of the European patent document. Even though great care has been taken in compiling the references, errors or omissions cannot be excluded and the EPO disclaims all liability in this regard.

Patent documents cited in the description

- ES 1079052 [0005]
- JP 2004123155 B [0006]
- JP 2003327266 B [0006]
- WO 2015101655 A [0008] [0036]
- EP 2675719 A [0009]
- US 2009301988 A1 [0011]
- US 2016325893 A1 [0012]