

(19)



(11)

**EP 3 572 134 A1**

(12)

**EUROPEAN PATENT APPLICATION**

(43) Date of publication:  
**27.11.2019 Bulletin 2019/48**

(51) Int Cl.:  
**A63H 1/00 (2019.01) A63F 5/00 (2006.01)**  
**A63F 9/16 (2006.01)**

(21) Application number: **19000249.3**

(22) Date of filing: **21.05.2019**

(84) Designated Contracting States:  
**AL AT BE BG CH CY CZ DE DK EE ES FI FR GB GR HR HU IE IS IT LI LT LU LV MC MK MT NL NO PL PT RO RS SE SI SK SM TR**  
Designated Extension States:  
**BA ME**  
Designated Validation States:  
**KH MA MD TN**

(71) Applicant: **Hercog, Ivan**  
**8250 Brezice (SI)**

(72) Inventor: **Hercog, Ivan**  
**8250 Brezice (SI)**

(74) Representative: **Golmajer Zima, Marjanca**  
**Patentna pisarna d.o.o.**  
**Copova 14**  
**1000 Ljubljana (SI)**

(30) Priority: **22.05.2018 SI 201800120**

(54) **ROULETTE WHEEL DEVICE**

(57) The invention relates to a roulette game device (1) comprising a spinning top (2) further comprising a stem (3), a gripping portion (4) connected to the stem at one end, wherein the stem and the gripping portion are formed of a non-magnetic material, and a magnetic tip (5) connected to the stem at the other end, and a disk-shaped flywheel (6) arranged between the magnetic tip (5) and the stem (3) coaxially with the stem axis, and a metallic ring (7) made from a magnetic material, the upper side of said ring having peripherally marked and

numbered pockets (8). During use, the user arranges the metallic ring (7) on a flat smooth surface, places the magnetic tip of the spinning top (2) on the inner edge of the metallic ring and twirls the top with his fingers around its axis. The rotation of the spinning top (2) causes the metallic ring (7) to spin around its own axis and to rotate around the axis of the spinning top. When the spinning top stops, it falls to the base and its magnetic tip (5) points at the winning number.

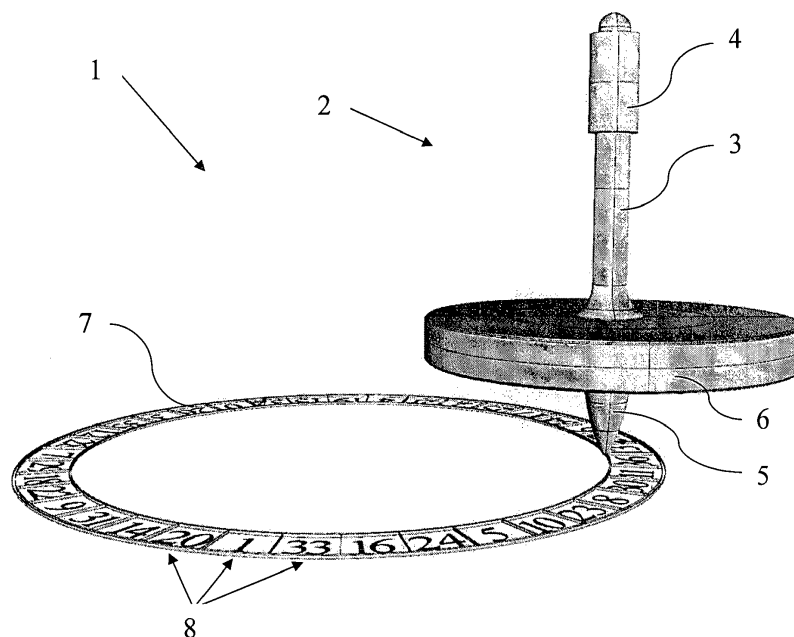

Figure 1

**EP 3 572 134 A1**

## Description

### Field of Invention

[0001] The invention refers to a roulette game device and to a kit of parts for a roulette game.

### Prior Art

[0002] From the prior art, roulette wheel devices are known which comprise a fixed bowl-shaped housing and a disc with numbered pockets for receiving a ball, said disk being rotatably mounted in said housing. The player spins the rotary disc in one direction and then spins a ball in the opposite direction around the periphery of the bowl-shaped housing. After a certain time, the speed of the ball is reduced so much that the force of gravity is greater than the centrifugal force of the ball, and the ball falls onto the rotary disc and stops in one of the numbered pockets.

[0003] Professional roulette wheel devices used in casinos are known. They are made of high quality materials, with high precision of manufacture. On the other hand, there are roulette game devices that are intended for home use. In their basic structure, they are the same as professional roulette wheel devices only that they are made of cheaper materials (usually made of plastic) and with less precision of manufacture due to commercial reasons.

### Technical Problem

[0004] The technical problem is how to provide a roulette game device that is suitable for home use and at the same time suitable as a business gift. The aforementioned requirements mean that the roulette game device must have a simple construction that will allow a low market price on one hand and that will not give an impression of being tasteless on the other.

### Solution to the Technical Problem

[0005] The technical problem is solved by a roulette game device comprising:

a spinning top further comprising a stem, a gripping portion connected to the stem at one end, wherein the stem and the gripping portion are formed of a non-magnetic material, and a magnetic tip connected to the stem at the other end, and a disk-shaped flywheel arranged between the magnetic tip and the stem coaxially with the stem axis, and

a metallic ring made from a magnetic material, the upper side of said ring having peripherally marked and numbered pockets.

[0006] The magnetic tip can be connected to the stem

by a detachable connection, such as a screw connection, or by a non-detachable connection, such as glue.

[0007] The magnetic tip can be formed of a magnetized solid magnetic material.

[0008] Alternatively, the magnetic tip can be formed of a magnetic material having a cylindrical receiving space in axial direction and a permanent magnet received in the cylindrical receiving space.

[0009] Preferably, the lower side of the metallic ring is coated with a material having a low friction coefficient, e. g. with polytetrafluoroethylene (PTFE), thereby achieving better sliding of the metallic ring on the base.

[0010] During use, the user arranges the metallic ring on a flat smooth surface (for example on the surface of a table), places the magnetic tip of the spinning top on the inner edge of the metallic ring and twirls the top with his fingers around its axis. The magnetic tip with its magnetically attractive force acts on the metallic ring. The rotation of the spinning top causes the metallic ring to spin around its own axis and to rotate around the axis of the spinning top. When the spinning top stops, the metallic ring stops, too. The spinning top falls to the base and its tip points at the winning number on the metallic ring.

[0011] The construction of the roulette game device of the invention represents an alternative to known roulette game devices used in a home environment.

[0012] A simple construction and a small number of components allow for a low production cost, while the appearance of the roulette game device is attractive and is therefore also suitable for business gifts.

Figure 1: Roulette game device

Figure 2: Cross-section of a spinning top with a permanent magnet (flywheel not shown)

Figure 3: Disk-shaped base

[0013] The invention is described in more detail hereinbelow.

[0014] The technical problem is solved by a roulette game device 1 comprising:

a spinning top 2 further comprising a stem 3, a gripping portion 4 connected to the stem at one end, wherein the stem and the gripping portion are formed of a non-magnetic material, and a magnetic tip 5 connected to the stem at the other end, and a disk-shaped flywheel 6 arranged between the magnetic tip 5 and the stem 3 coaxially with the stem axis, and a metallic ring 7 made from a magnetic material, the upper side of said ring having peripherally marked and numbered pockets 8.

[0015] The stem 3 and the gripping portion 4 are preferably integrally formed.

[0016] The magnetic tip 5 can be connected to the stem 3 by a detachable connection, such as a screw connection, or by a non-detachable connection, such as glue.

**[0017]** The magnetic tip 5 can be formed of a magnetized solid magnetic material.

**[0018]** Alternatively, the magnetic tip 5 can be formed of a magnetic material having a cylindrical receiving space 9 in axial direction and a permanent magnet 10 received in the cylindrical receiving space 9.

**[0019]** Preferably, the lower side of the metallic ring 7 is coated with a material having a low friction coefficient, e.g. with polytetrafluoroethylene (PTFE), thereby achieving better sliding of the metallic ring on the base.

**[0020]** During use, the user arranges the metallic ring 7 on a flat smooth surface (for example on the surface of a table), places the magnetic tip of the spinning top 2 on the inner edge of the metallic ring and twirls the top with his fingers around its axis. The magnetic tip 5 with its magnetically attractive force acts on the metallic ring. The rotation of the spinning top 2 causes the metallic ring 7 to spin around its own axis and to rotate around the axis of the spinning top. When the spinning top stops, the metallic ring stops, too. The spinning top falls to the base and its magnetic tip 5 points at the winning number on the metallic ring.

**[0021]** The disk-shaped flywheel 6 is preferably made of a transparent material, such as glass or plastics. This provides for a better visibility of the number disk from all sides.

**[0022]** The roulette game device 1 can further comprise a disk-shaped base 11 of a non-magnetic material having a diameter corresponding to about twice the diameter of the metallic ring 7. The upper face of the disk-shaped base 11 is preferably coated with a material 12 having a low friction coefficient. Examples of suitable materials are polytetrafluoroethylene (PTFE), velvet and felt.

**[0023]** The disk-shaped base 11 can further comprise a centrally arranged seat 13 for the magnetic tip of the spinning top, which is formed in the shape of a cavity.

**[0024]** The kit of parts for the roulette game comprises the roulette game device 1, a table layout for placing bets, and chips.

## Claims

1. A roulette game device (1) comprising:

- a spinning top (2) further comprising

- a stem (3),
- a gripping portion (4) connected to the stem at one end, wherein the stem and the gripping portion are formed of a non-magnetic material, and
- a magnetic tip (5) connected to the stem at the other end, and
- a disk-shaped flywheel (6) arranged above the magnetic tip (5) and around the stem (3) coaxially with the stem axis, and

- a metallic ring (7) made from a magnetic material, the upper side of said ring having peripherally marked and numbered pockets (8).

5 2. Device according to Claim 1, **characterized in that** the magnetic tip (5) is connected to the stem (3) by a detachable connection, such as a screw connection.

10 3. Device according to Claim 1, **characterized in that** the magnetic tip (5) is connected to the stem (3) by a non-detachable connection, such as glue.

15 4. Device according to any of Claims 1 to 3, **characterized in that** the magnetic tip (5) is formed of a magnetized solid magnetic material.

20 5. Device according to any of Claims 1 to 3, **characterized in that** the magnetic tip (5) is formed of a magnetic material having a cylindrical receiving space (9) in axial direction and a permanent magnet (10) received in the cylindrical receiving space (9).

25 6. Device according to any of Claims 1 to 5, **characterized in that** the lower side of the metallic ring (7) is coated with a material having a low friction coefficient, e.g. with polytetrafluoroethylene (PTFE), velvet or felt.

30 7. Device according to any of Claims 1 to 6, **characterized in that** the stem (3) and the gripping portion (4) are integrally formed.

35 8. Device according to any of Claims 1 to 7, **characterized in that** a disk-shaped flywheel (6) is formed of a transparent material, such as glass or plastics.

40 9. Device according to any of claims 1 to 8, **characterized by** further comprising a disk-shaped base (11) of a non-magnetic material having a diameter corresponding to about twice the diameter of the metallic ring (7).

45 10. Device according to Claim 9, **characterized in that** the upper face of the disk-shaped base (11) is coated with a material (12) having a low friction coefficient, e.g. with polytetrafluoroethylene (PTFE).

50 11. Device according to Claims 9 or 10, **characterized in that** the disk-shaped base (11) further comprises a centrally arranged seat (13) for the magnetic tip of the spinning top, which is formed in the shape of a cavity.

55 12. A kit of parts for the roulette game comprising the device according to any of claims 1 to 11, a table layout for placing bets, and chips.

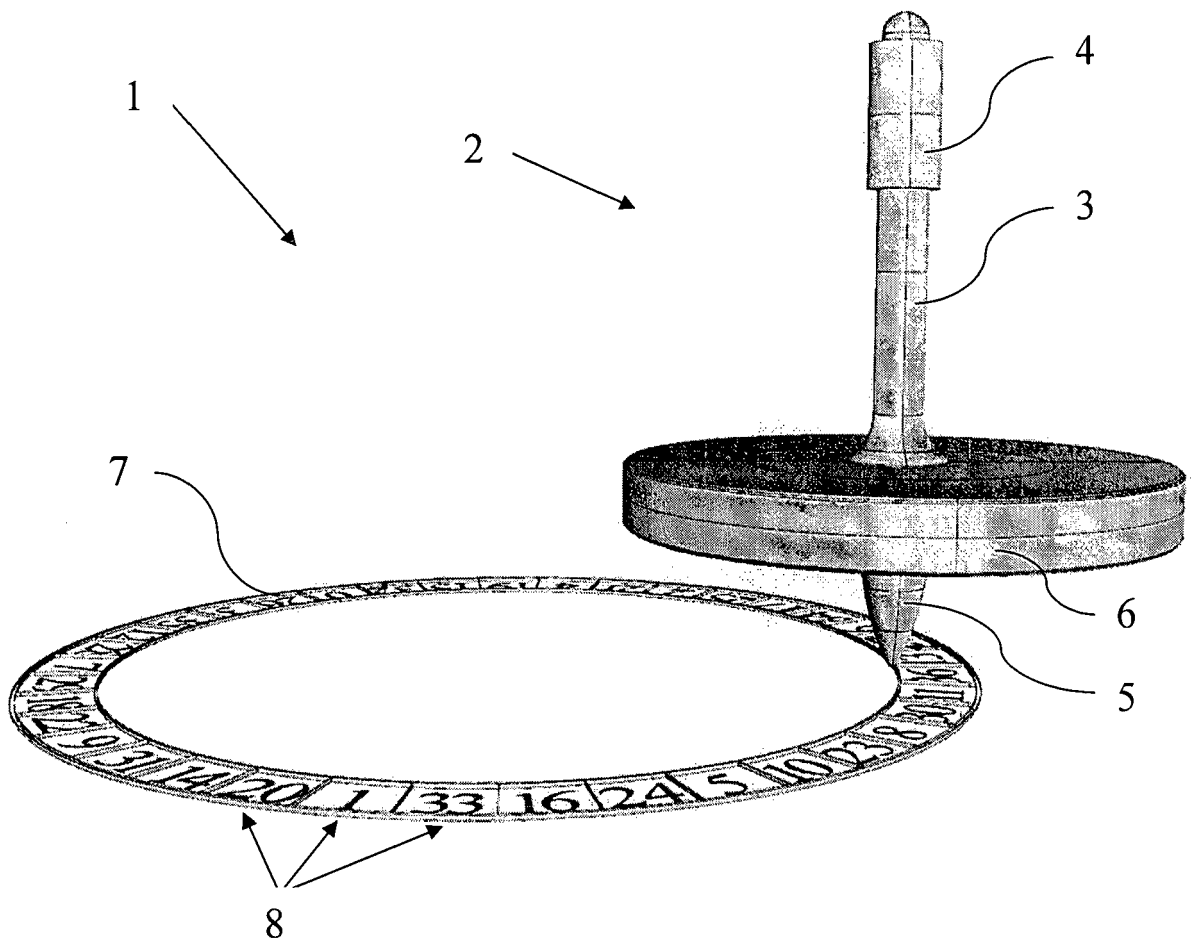

Figure 1

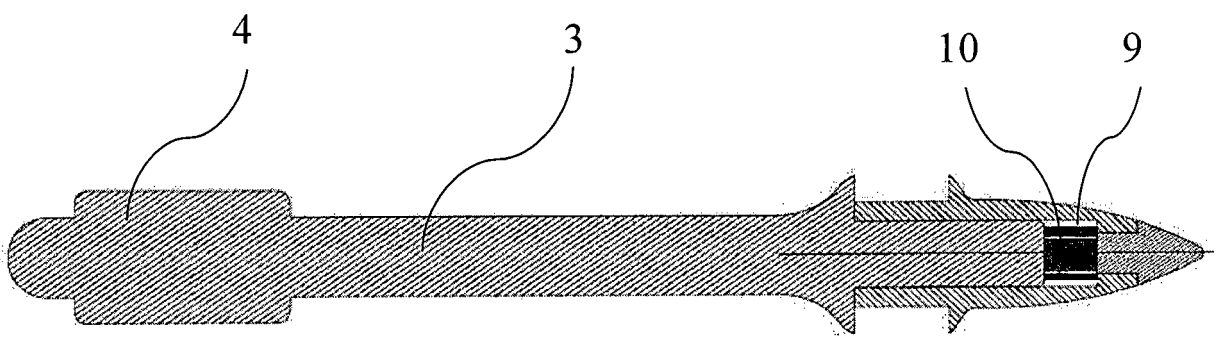

Figure 2

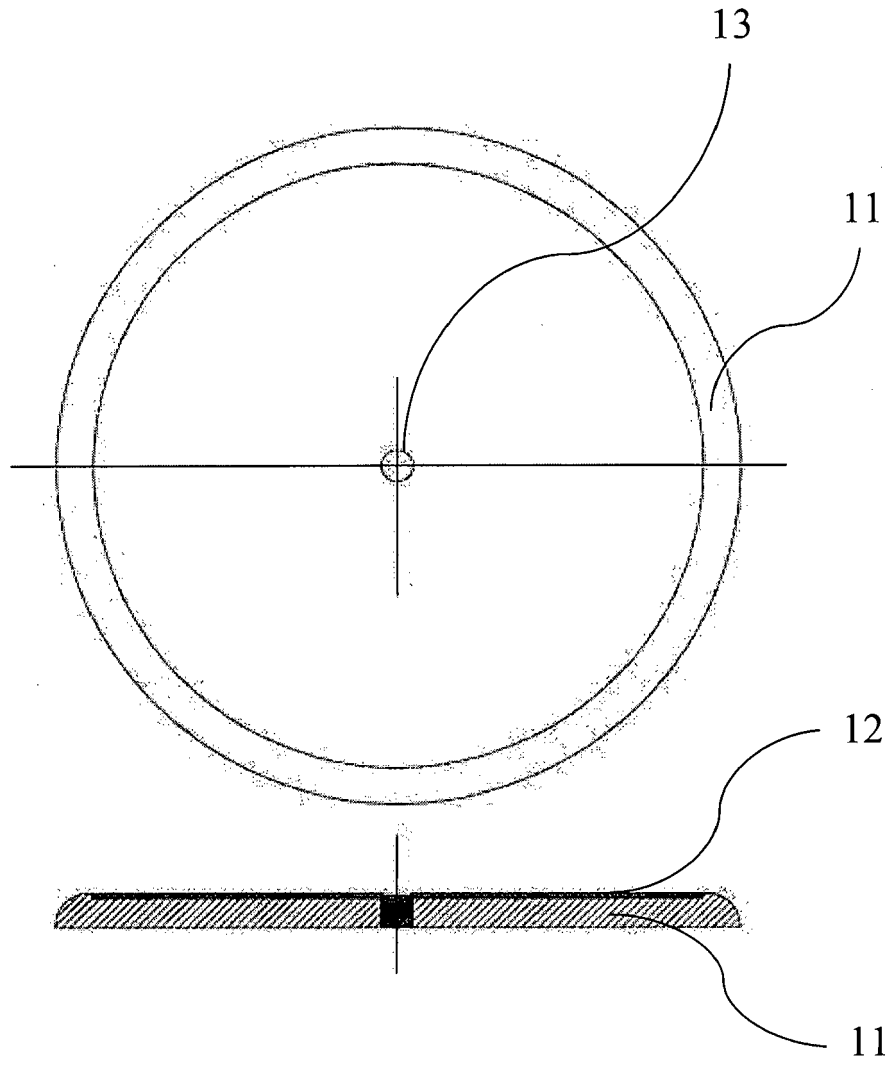

Figure 3



EUROPEAN SEARCH REPORT

Application Number  
EP 19 00 0249

5

DOCUMENTS CONSIDERED TO BE RELEVANT			
Category	Citation of document with indication, where appropriate, of relevant passages	Relevant to claim	CLASSIFICATION OF THE APPLICATION (IPC)
A	GB 611 947 A (HAROLD ASKEW SMITH) 5 November 1948 (1948-11-05) * page 1, line 74 - page 4, line 16; figures *	1-12	INV. A63H1/00 A63F5/00 A63F9/16
A	FR 2 862 233 A1 (PARMENTIER CLAUDE [FR]) 20 May 2005 (2005-05-20) * page 2, line 30 - page 6, line 4; figures *	1-12	
A	US 2011/009028 A1 (GURDIN JONATHAN M [US] ET AL) 13 January 2011 (2011-01-13) * paragraph [0062] - paragraph [0083]; figures *	1-12	
A	GB 2 238 000 A (REYNOLDS DAVID CHARLES; STEYNOR VICTOR PENN) 22 May 1991 (1991-05-22) * page 5, line 16 - page 10, line 20; figures *	1-12	
A	DE 200 04 407 U1 (KUSCHEW CORNELIA [DE]) 13 July 2000 (2000-07-13) * the whole document *	1-12	TECHNICAL FIELDS SEARCHED (IPC) A63H A63F
The present search report has been drawn up for all claims			
Place of search Munich		Date of completion of the search 20 September 2019	Examiner Lucas, Peter
CATEGORY OF CITED DOCUMENTS X : particularly relevant if taken alone Y : particularly relevant if combined with another document of the same category A : technological background O : non-written disclosure P : intermediate document		T : theory or principle underlying the invention E : earlier patent document, but published on, or after the filing date D : document cited in the application L : document cited for other reasons & : member of the same patent family, corresponding document	

EPO FORM 1503 03/02 (P04C01)

10

15

20

25

30

35

40

45

50

55

ANNEX TO THE EUROPEAN SEARCH REPORT  
ON EUROPEAN PATENT APPLICATION NO.

EP 19 00 0249

5

This annex lists the patent family members relating to the patent documents cited in the above-mentioned European search report. The members are as contained in the European Patent Office EDP file on  
The European Patent Office is in no way liable for these particulars which are merely given for the purpose of information.

20-09-2019

10

Patent document cited in search report		Publication date	Patent family member(s)	Publication date
GB 611947	A	05-11-1948	NONE	
FR 2862233	A1	20-05-2005	FR 2862233 A1 WO 2005049161 A1	20-05-2005 02-06-2005
US 2011009028	A1	13-01-2011	US 2011009028 A1 WO 2009145951 A1	13-01-2011 03-12-2009
GB 2238000	A	22-05-1991	NONE	
DE 20004407	U1	13-07-2000	NONE	

15

20

25

30

35

40

45

50

55

EPO FORM P0459

For more details about this annex : see Official Journal of the European Patent Office, No. 12/82