



(12) **EUROPEAN PATENT APPLICATION**

(43) Date of publication:
26.02.2020 Bulletin 2020/09

(51) Int Cl.:
E04F 13/08 (2006.01)

(21) Application number: **18020396.0**

(22) Date of filing: **21.08.2018**

(84) Designated Contracting States:
AL AT BE BG CH CY CZ DE DK EE ES FI FR GB GR HR HU IE IS IT LI LT LU LV MC MK MT NL NO PL PT RO RS SE SI SK SM TR
 Designated Extension States:
BA ME
 Designated Validation States:
KH MA MD TN

(71) Applicant: **Hernampérez Cuesta, Juan Ramón**
08915 Badalona (Barcelona) (ES)

(72) Inventor: **Hernampérez Cuesta, Juan Ramón**
08915 Badalona (Barcelona) (ES)

(74) Representative: **Díaz Nunez, Joaquín**
J.D. Núñez Patentes y Marcas, S.L.
Rambla Catalunya 120
08008 Barcelona (ES)

(54) **SUPPORT CLAMP FOR FAÇADE CLADDING STRUCTURES**

(57) SUPPORT CLAMP FOR FAÇADE CLADDING STRUCTURES, consisting of an extruded profile segment with: flat base(10), fixing screw (3) to the upright (2); support arm (11) and plate support, with one or two channels (12) to receive the lower or upper edge of the plate; and pressure wing (13), formed by a partition that emerges obliquely from the base (10) oriented towards the interior of said channel (12), limiting its width to the thickness of the plate, which is held in place by the pressure it exerts on the rear surface of the same. The clamp (1) slides along longitudinal guides (21) ribbed in C, provided in the uprights (2) of the structure. And the fixing screw (3) is self-piercing whose penetration pivot does not protrude from the base (10) until completely threaded.

FIG. 1

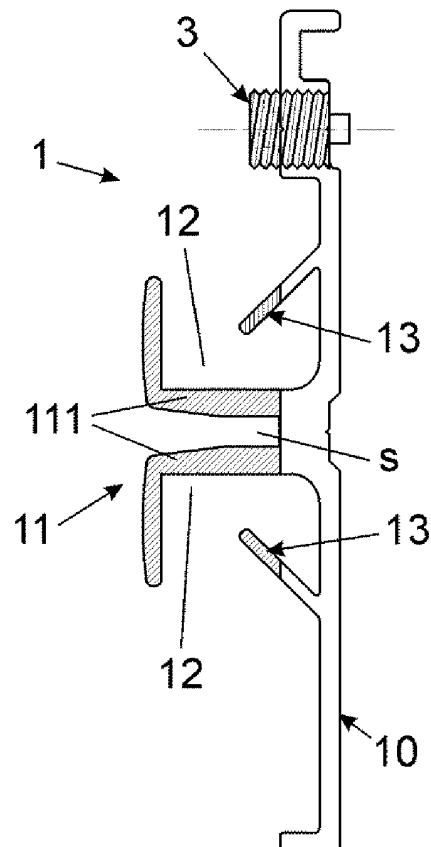

Description**OBJECT OF THE INVENTION**

[0001] The invention, as expressed in the present description, refers to a support clamp for façade cladding structures, which contributes structural and constitutive characteristics, described in detail below, that imply remarkable novelty for the current state of the art within its field of application.

[0002] More particularly, the object of the invention focusses on a fixing piece, constituted as a clamp, whose purpose is to act as a support to provide a practical and safe means for securing plates or panels (hereinafter 'plates' when referring to both) intended for the surface cladding of facades, whether ventilated or not, as part of the sustaining structure with which they are installed, which is preferably designed for its use in structures of guided profiling, that is, structures that comprise uprights formed by profiles that include, at least, a guide on its frontal face for the inclusion of the clamp as a sliding support element, allowing the regulation of the position thereof before fixing the plates, whose clamp, in any case, differs in that it consists of an extruded profile segment with a studied structural configuration that, among other characteristics, comprises a wing that exerts pressure on the plate inserted in the housing that defines said wing, which advantageously optimizes its function and improves on that currently known.

FIELD OF APPLICATION OF THE INVENTION

[0003] The field of application of the present invention is framed in the construction sector, focussing particularly on the scope of the manufacturing and installation of support structures for façade cladding.

BACKGROUND OF THE INVENTION

[0004] Facades that are covered with overlapping plates on their surface, for the correct sustainment and alignment of the same, usually incorporate a metallic support structure, which in the case of ventilated facades contemplates the existence of an intermediate space for the laying of insulating materials and an air chamber, whose structure usually comprises a plurality of vertical uprights that, by means of screwed anchoring, are fixed on the wall or surface to be covered of the building structure, which, in turn, have support elements incorporated for fixing each of the plates that constitute the cladding, support elements that can be of a different nature, with the clamp of the present invention being designed as an improved alternative to the different existing solutions in the market to date of the aforementioned support elements, with the improvements that it provides focussed, particularly, on the clamping means to the plate incorporated and on clamping facility, effectiveness and efficacy, in addition to the saving of material and installation time.

[0005] More specifically, the main problem that the clamp of the present invention aims to overcome is that of the movement of plates fixed with known support elements, particularly when it comes to those that support the plates at the bottom and top through the insertion of an angle provided therein, embedded in a groove made for this purpose on the top and bottom edge of the plate.

[0006] The problem of this type of securing, on the one hand, is the limitation of the thickness of the plates, since said thickness cannot be below a certain limit in order to accommodate the existence of said grooves without compromising the integrity of the piece. And on the other hand, no matter how much tolerance is adjusted between the dimensions of the groove and angle, the aforementioned minimum tolerance must always exist, meaning that movement of the plate on the supports always exists which, often provoked by the wind, vibrations of nearby roads, the impact of foreign objects, birds or other causes, can become an inconvenience and/or cause deterioration in the material or structure.

[0007] On the other hand, it should be noted that conventional clamps are usually fixed by screwing them into vertical uprights, for which the aforementioned fixing must be carried out previously and after making the corresponding measurements for placing it in the specific point intended, which, in addition to being laborious, can lead to errors and a need for posterior rectifications of the position in which the clamps are fixed, for which reason, another target of the present invention is the development of a sliding clamp, that is, designed for incorporation in uprights provided with guides that allow placement of the clamps therein prior to them being fixed and allow varying their position before the placement of the plate, with another of the objectives of the invention being the development of a clamp variant that allows the placement and removal of said clamp after fixing of the upright by the front of the guides, so as to provide a practical and convenient way of replacing any of the plates of a finished façade without the need to dismantle any other adjacent plates and without the need to manufacture a special piece, on being obtained from the same structural design of extruded profile.

[0008] At all events, and as a reference to the current state of the art, it should be pointed out that, at least on the part of the applicant, the existence of any other support clamp for façade cladding structures, or any other invention with a similar application, that presents any technical, structural and constitutive characteristics equal or similar to those claimed herein, is unknown.

DESCRIPTION OF THE INVENTION

[0009] The support clamp for façade cladding structures that the invention proposes is configured, therefore, as a novelty within its field of application, since in accordance with its implementation and in a limiting manner, the aforementioned objectives are reached satisfactorily, with the characterizing details that make it possible and

that distinguish it being suitably collected in the final claims that accompany the present description.

[0010] In particular, the clamp that the invention proposes, as previously stated, is a fixing part, which acts as a support for the securing of façade cladding plates, said façades being ventilated or not, to the vertical uprights of the sustaining structure with which they are installed, being particularly designed for use in a structure of guided profiling, that is, a structure whose vertical uprights are profiles provided with one or more longitudinal guides that allow sliding of the clamp, which, in any case, differs, essentially, in that the said piece that constitutes it is an extruded profile segment whose structural configuration, among other characteristics, comprises a wing that exerts pressure on the plate inserted in the housing it defines.

[0011] For said purpose, and more specially, the aforementioned configuration of the extruded profile segment that forms the constitutive part of the clamp of the invention comprises, essentially, a substantially flat base, where a screw is incorporated for its fixation to the upright, a support and sustaining arm, which emerges perpendicularly from the base, defining, at least, a suitable channel to receive, at least, a portion of the bottom or top edge of the plate, and a pressure wing that, formed by a thin partition that emerges obliquely from the base orienting its end towards the inside of said channel, limits the width thereof defining a housing fitted without tolerance to the dimensions of the portion of the plate edge that is inserted in the channel, in such a way that the wing determines a weak point, capable of minimally flexing to allow the adjusted passage of the plate edge and, once inserted, on occupying its natural position, exerts pressure on the surface of the plate, securing it and preventing it from moving as there is no tolerance.

[0012] Additionally, depending on the intended position of the clamp, that is, the initial position, to support the bottom edge of the plates of the bottom row or to support the top edge of the plates of the top row, or the intermediate positions, to support at the same time the top and bottom edges of overlapping adjacent plates in column, the support and sustaining arm defines either a single channel, with an L section configuration, or two symmetrical channels, with a T section configuration, while contemplating the existence of one or two wings, one in each of the said channels.

[0013] Likewise, according to another characteristic of the invention, the aforementioned support and sustaining arm can have a horizontal section of greater or lesser thickness, depending on whether the plates are mounted with greater or lesser width in the joint provided between them, being as narrow as 2 mm. For its part, the vertical section or sections of this support and sustaining arm are visible, when the plate edge is fully incorporated into the channel it defines, or remain concealed when inserted in a longitudinal groove provided along the plate edge with the aim of inserting it inside, so that only a portion of the edge is lodged in the clamp channel, the posterior and previous

one covers it frontally.

[0014] Furthermore, as mentioned previously, in the preferred embodiment of the clamp, the latter is a sliding clamp and is designed for its incorporation in a structure of guided profiling, that is, with vertical uprights provided with one or more longitudinal guides where the clamp is inserted and can slide along said guide or guides to place it in a suitable position before fixing it, preferably having, for said fixation, a self-drilling set screw with an oppressive pivot at its penetration end and Allen type housing \odot for screwing, which minimizes the need for space at the back of the upright, allowing the assembling of non-ventilated structures with minimal space and, additionally, placement of the clamp is much faster and more practical, since said clamp may already be inserted in the upright before fixing said upright to the wall and can already have the screws incorporated, given that said screw has a very short point of penetration that does not interfere with the sliding of the clamp through the guide of the upright until it is fully threaded, all of which implies a significant saving of time when assembling.

[0015] Thus, in the aforementioned preferred embodiment for uprights with guides, the base of the part that defines the clamp is formed by a substantially flat body of a rectangular configuration, and a width according to the width of the back wall of the upright guides, which, preferably, are guides that have a ribbed shape of C section, with frontal ribs that close the respective flanks of the frontal opening of the guides, thus preventing the entry or exit of said base since said opening has a lesser width, whilst the support and sustaining arm and the wing provided in the channel, have a lesser width than the base and a width according to that of the mouth of the guides. For this, the extruded profile forming the part that defines said clamp, after being cut in the width segment of the base, undergoes machining to reduce the width of the arm and the wings.

[0016] And, in an alternative embodiment for said upright structures with the aforementioned ribbed guides, the base is formed by a body of an equally flat configuration, parallelepiped but rhomboid in shape, instead of rectangular, where the width between its greater sides as well as the width of the support arm and that of the wings is according to the width of the mouth of said ribbed guides of the uprights, whereby the clamp can be inserted and removed from the guide through its mouth or opening, that is, frontally, by simply turning it slightly to place its long sides in parallel with the sides of the mouth and, once inserted, turning it again slightly so that its diametrically opposed ends are lodged behind the ribs of the opening which will prevent its exit from the guide, thus allowing the individual replacement of any of the façade plates, regardless of the place they occupy.

[0017] Moreover, in this case, the manufacturing of the piece is more economical because, apart from not constituting a piece with a different design since its extruded profile is identical, its obtaining only implies the execution of the cut that defines the profile segments with a certain

slant.

[0018] Finally, it should be mentioned that the clamp, in particular its base, can have a greater or lesser height, according to the needs of each case, with a short base option being preferable to reduce the quantity of material needed for its manufacturing and, thereby, reducing its economic cost and, consequently, that of the entire structure.

[0019] The described support clamp for façade cladding structures represents an innovative structure of structural and constitutive characteristics unknown until now for the purpose for which it is intended, reasons that when taken together with its practical use, provide it with sufficient base to obtain the privilege of exclusivity requested.

DESCRIPTION OF THE DRAWINGS

[0020] To complement the description and in order to offer a better understanding of the characteristics of the invention, a set of drawings accompany the present description, as an integral part of the latter, in which, with illustrative and not limitative character, the following has been represented:

Figures 1, 2 and 3 each show different views, a top lateral view, top frontal view and top plan view respectively, of the first embodiment example of the support clamp for façade cladding structures, object of the invention, showing the parts and main elements that it comprises, as well as the configuration and disposition thereof.

Figures 4, 5 and 6 each show different views, a top lateral view, top frontal view and top plan view respectively, of the second embodiment example of the support clamp, according to the invention, in particular an example for the installation of plates with limited joint, where a different configuration can be seen of some of its parts in particular that of the central arm it comprises.

Figures number 7, 8 to 9 each show different views, a top lateral view, top frontal view and top plan view respectively, of a third example of embodiment of the support clamp, according to the invention, in particular an example for the individual replacement of plates, where a different configuration can be seen of some of its parts, in particular that of the base it comprises.

Figure 10 shows a top lateral view of another embodiment example of the clamp, object of the invention, in particular an example of the initial clamp, to be placed at the beginning and end of the column of overlapping plates.

Figures 11A and 11B each show different top plan

views of two vertical upright examples, with a rib and without a central rear rib respectively, to which two clamps have been incorporated in the guides of their front side, where the way in which these are incorporated in the sustaining structure of the façade can be seen.

Figure 12 shows a top lateral view of an additional embodiment example of the clamp of the invention, in particular an example of an intermediate clamp of a more reduced height to save material.

[0021] And figure 13 shows an enlarged view of the detail A indicated in figure 12, where the flexion of the wing can be seen to facilitate the insertion of the plate edge.

PREFERRED EMBODIMENT OF THE INVENTION

[0022] In view of the aforementioned figures, and in accordance with the adopted numeration, one can see in them several but not limitative embodiment examples of the recommended support clamp for façade cladding structures, which comprises the parts and elements that are indicated and described in detail below.

[0023] Thus, as can be observed in the aforementioned figures, the clamp (1) in question, applicable for the securing of façade cladding plates to vertical uprights (2) of a sustaining structure, consists of a piece formed from a segment of extruded profile whose structural configuration comprises, essentially: a flat base (10), where it incorporates a screw (3) for its fixing to the upright (2); a support and sustaining arm (11) of the plate, which emerges perpendicularly from the base (10), defining, at least, a channel (12) capable of receiving the entire thickness, or a portion when the plate is provided with a longitudinal groove, of the bottom or top edge of the plate; and a pressure wing (13), formed by a thin partition that emerges obliquely from the base (10), preferably at 45°, oriented towards the inside of said channel (12) so as to limit the width of the channel (12) to a housing of a width adjusted, without tolerance, to the dimensions of the said thickness or said portion of the thickness of the plate, and exerts pressure on the rear surface thereof, securing it and preventing it from moving, once placed. In figure 13 one can see the flexibility that said wing (13) has at its end, thanks to which it causes pressure on the rear surface of the plate.

[0024] In reference now to figure 10, it can be observed how, when the clamp (1) is initial, that is, intended to be placed in the initial position, to secure the bottom edge of the plates of the bottom row or to secure the top edge of the plates of the top row, the support and sustaining arm (11) has an L-section configuration that defines a single channel (12) with a pressure wing (13). And, as can be observed in figures 1 to 9, when the clamp (1) is intermediate, that is, intended to be incorporated in intermediate positions, to secure at the same time the top

edge and the bottom edge of adjacent overlapping plates in column, the arm (11) has a T-section configuration that defines two symmetrical channels (12), a bottom one to secure the top edge of a lower plate, and a top one to secure the bottom edge of an upper plate, with each of the aforementioned channels (12) in turn having the corresponding pressure wings (13) which, logically, are also arranged symmetrically.

[0025] Optionally, when the clamp (1) is intermediate and the support and sustaining arm (11) has a T-configuration that defines two channels (12) with respective pressure wings (13), said arm (11) has either a double horizontal section (111) that determines an ample gap (s) between said channels (12) and, consequently, a joint of notable width between the plates, as can be observed in the examples of figures 1 to 3, even being able to incorporate the fixing screw (3) in the aforementioned space, as in the examples of figures 7 to 9, although it can also be placed in other base points (10), or said arm (11) has a unitary horizontal section (111) of minimal thickness, preferably of between 2 to 10 mm, which in such case determines a limited gap between the aforementioned channels (12) and, consequently, a joint of reduced width between the plates.

[0026] In any case, preferably, the clamp (1) slides along longitudinal guides (21) provided for that purpose in uprights (2) of the structure, so as to be placed where appropriate during assembling, and the fixing screw (3), preferably, is a self-drilling set screw with an oppressive pivot at its penetration end that does not protrude from the base (10) until completely threaded, allowing the sliding of the clamp (1) in the guides (21) with the screw incorporated prior to its fixation.

[0027] As can be observed in figures 11A and 11B, the guides (21) of the uprights (2) are in the frontal face (22) thereof, while at the back said uprights may have a central rib (23) for the incorporation of anchors leaving an air chamber and for insulating material in the case of ventilated facades, as is shown in the example of figure 11A, but they can also do without said central rib (23), as is shown in figure 11B, in which case, thanks to the fact that the oppressive pivot of the self-drilling set screw (3) does not protrude from the back of the upright (2), it is possible to assemble the front cladding with a minimal space between the plate and the structure of the building in which said uprights (2) are anchored.

[0028] In the example of figure 1 one can observe how the screw (3) placed in the clamp (1) prior to its complete threading, does not extend beyond the rear face of the base (10), while in figure 4 one can see how, once said threading of the screw has been completed (3) it extends beyond said rear face of the base (10), thereby piercing the guide (21) of the upright (2) and remaining fixed to it.

[0029] Moreover, in the preferred embodiment of the clamp (1) for uprights (2) with guides (21), like that of the examples shown in figures 1 to 6 and 10 to 2, the flat base (10) of the clamp (1) has a rectangular configuration, with a width (a) according to the width of the back

wall of the aforementioned guides (21) of the upright (2) to fit lodged within, the guides (21) of the upright (2) which, preferably, have a ribbed shape of C section, with frontal ribs that close the respective flanks of their frontal opening, preventing the entry or exit of said base (10) of the clamp due to said opening having a lesser width, while the support and sustaining arm (11) and the wing (13) have lesser widths than that of the base (10) and according to the width of the mouth of the guides (21).

[0030] And, in another embodiment option, equally applicable for uprights (2) with said guides (21) in C, the flat base (10) of the clamp (1) has a rhomboid configuration, as that of the example of figures 7 to 9, mainly seen in figure 8, with a width (a) according to the width of the mouth of the aforementioned guides (21) of the uprights (2) that allows its insertion and frontal removal through said mouth in oblique position, remaining locked in the guide (21) on turning it and placing the arm (11) and wings (13) horizontally, since the lateral sides determine an angle (n) different from 90° with the axis (e) perpendicular to the horizontal section (111) of the arm (11) that defines the support surface of the channel (12) on which the edge of the plate is incorporated. As can be observed in said figures 7 and 8, in this option the screw (3) is incorporated in the horizontal double section (11) of the arm (11) coinciding with the center of the base (10) to facilitate the aforementioned turning.

[0031] Having sufficiently described the nature of the present invention, as well as the way of implementing it, it is not considered necessary to give a more extensive explanation for any expert in the field to understand its scope and the advantages stemming from it, pointing out that, within its essentiality, it may be implemented in other embodiments that differ in detail from that indicated by way of example, and to which the protection sought shall be equally given, provided that its fundamental principle is not altered, changed or modified.

40 Claims

1. SUPPORT CLAMP FOR FAÇADE CLADDING STRUCTURES that, applicable for the fixing of façade cladding plates to vertical uprights (2) of a sustaining structure, is **characterized in that** it consists of a piece formed from an extruded profile segment whose structural configuration comprises: a flat base (10), where it incorporates a screw (3) for its fixing to the upright (2); a support and sustaining arm (11) of the plate, which emerges perpendicularly from the base (10), defining, at least, a suitable channel (12) to receive the entire thickness, or a portion when the plate is provided with a longitudinal groove, of the bottom or top edge of the plate; and a pressure wing (13), formed by a thin partition that emerges obliquely from the base (10) oriented towards the inside of said channel (12), limiting the width of said channel (12) to a housing whose width is adjusted,

- without tolerance, to the dimensions of said thickness or portion of the plate edge, which is secured by means of the pressure exerted by the end of said partition of said wing (13) on the rear surface thereof, preventing it from moving, once placed.
2. SUPPORT CLAMP FOR FAÇADE CLADDING STRUCTURES, according to claim 1, **characterized in that** the partition that forms the pressure wing (13) emerges from the base (10) at 45°.
 3. SUPPORT CLAMP FOR FAÇADE CLADDING STRUCTURES, according to claim 1 or 2, **characterized in that**, when the clamp (1) is initial, that is, intended to be placed in the initial position, to secure the bottom edge of the plates of the bottom row or to secure the top edge of the plates of the top row, the support and sustaining arm (11) has an L-section configuration that defines a single channel (12) with a pressure wing (13).
 4. SUPPORT CLAMP FOR FAÇADE CLADDING STRUCTURES, according to claim 1 ó 2, **characterized in that**, when the clamp (1) is intermediate, that is, intended to be incorporated in intermediate positions, to secure at the same time the top and bottom edges of overlapping adjacent plates in column, the arm (11) has a T-section configuration that defines two symmetrical channels (12), a bottom one to secure the top edge of a lower plate, and a top one to secure the bottom edge of an upper plate, each of the aforementioned channels (12) having in turn a pressure wing (13) that are also symmetrically arranged.
 5. SUPPORT CLAMP FOR FAÇADE CLADDING STRUCTURES, according to claim 4, **characterized in that** the support and sustaining arm (11) has a T configuration with a horizontal double section (111) that determines a wide gap (s) between the two channels (12) that it defines.
 6. SUPPORT CLAMP FOR FAÇADE CLADDING STRUCTURES, according to claim 5, **characterized in that** the fixing screw (3) is incorporated in the existing gap in the horizontal double section (111) of the support and sustaining arm (11).
 7. SUPPORT CLAMP FOR FAÇADE CLADDING STRUCTURES, according to claim 4, **characterized in that** the support and sustaining arm (11) has a T configuration that is provided with a unitary horizontal section (111) of minimal thickness, between 2 to 10 mm.
 8. SUPPORT CLAMP FOR FAÇADE CLADDING STRUCTURES, according to any of the claims 1 to 7, **characterized in that** it is a clamp (1) that slides along longitudinal guides (21) provided for this purpose in the uprights (2) of the structure.
 9. SUPPORT CLAMP FOR FAÇADE CLADDING STRUCTURES, according to claim 8, **characterized in that** the guides (21) of the upright (2) have a ribbed shape of C-section, with frontal ribs that close the respective flanks of their frontal opening.
 10. SUPPORT CLAMP FOR FAÇADE CLADDING STRUCTURES, according to claim 9, **characterized in that** the flat base (10) of the clamp (1) has a rectangular configuration, with a width (a) according to that of the back wall of said guides (21) of the upright (2) to fit lodged therein, while the support and sustaining arm (11) and the wing (13) are of a lesser width than the base (10) and according to the width of the mouth of the guides (21).
 11. SUPPORT CLAMP FOR FAÇADE CLADDING STRUCTURES, according to claim 9, **characterized in that** the flat base (10) of the clamp (1) has a rhomboid configuration, with a width (a) according to that of the mouth of the guides (21) of the uprights (2) for its insertion and frontal removal through the same in oblique position, and whose lateral sides determine an angle (n) different from 90° with the axis (e) lying perpendicular to the horizontal section (111) of the arm (11) of the clamp (1).
 12. SUPPORT CLAMP FOR FAÇADE CLADDING STRUCTURES, according to any of the claims 8 to 11, **characterized in that** the fixing screw (3) is a self-drilling set screw with an oppressive pivot at its penetration end, which does not protrude from the base (10) until completely threaded, allowing sliding of the clamp (1) in the guides (21) with the screw (3) incorporated prior to its fixation.

FIG. 1

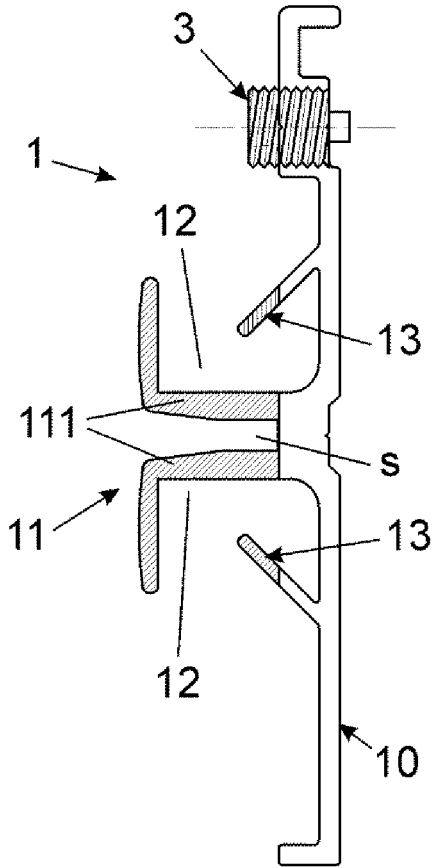

FIG. 2

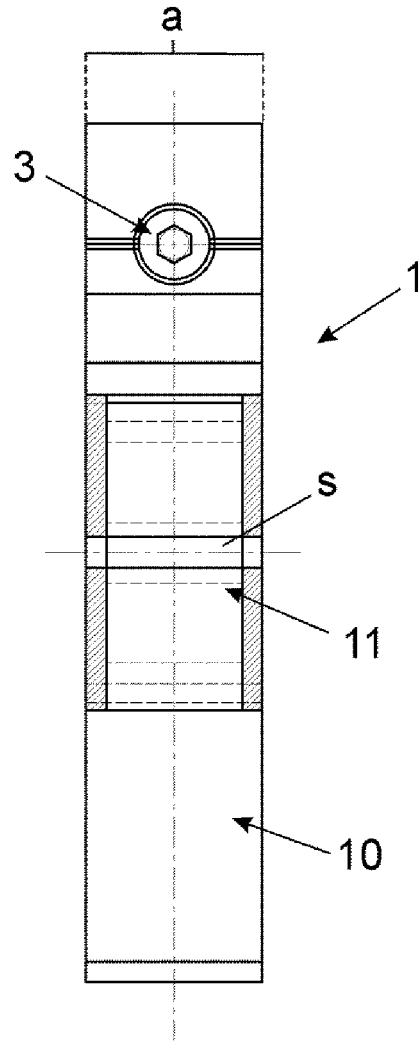

FIG. 3

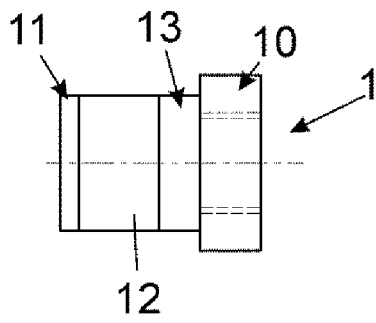

FIG. 4

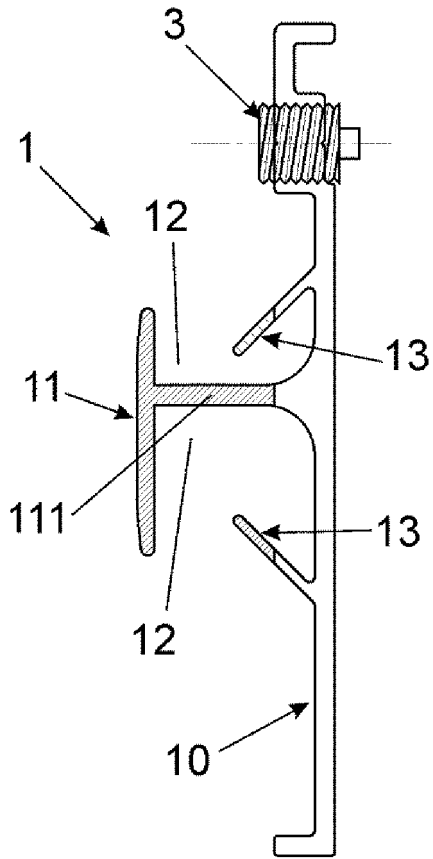

FIG. 5

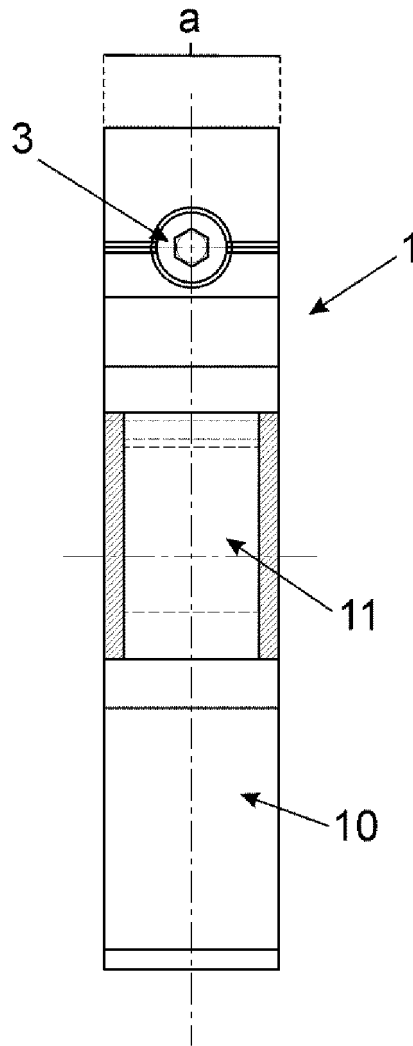

FIG. 6

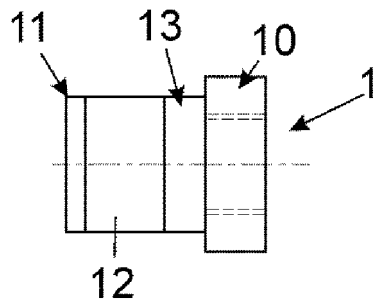

FIG. 7

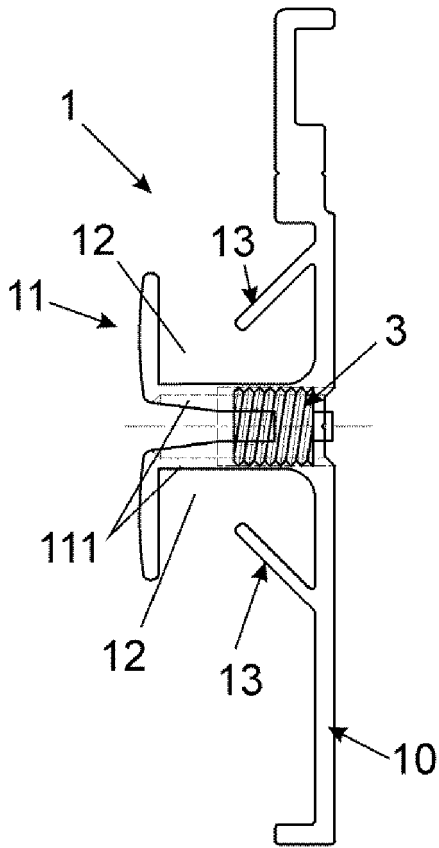

FIG. 8

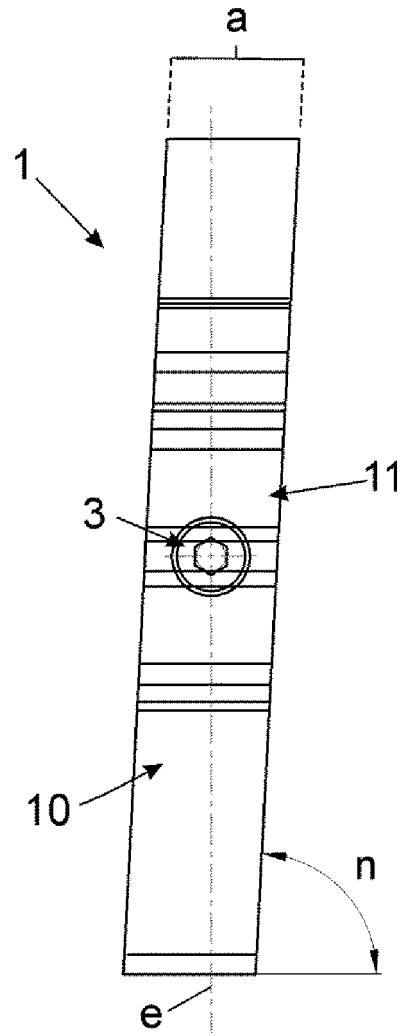

FIG. 9

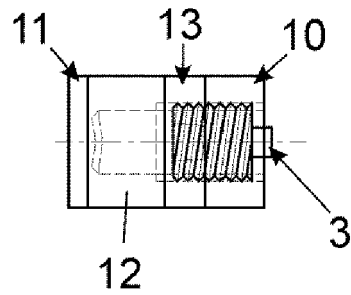

FIG. 10

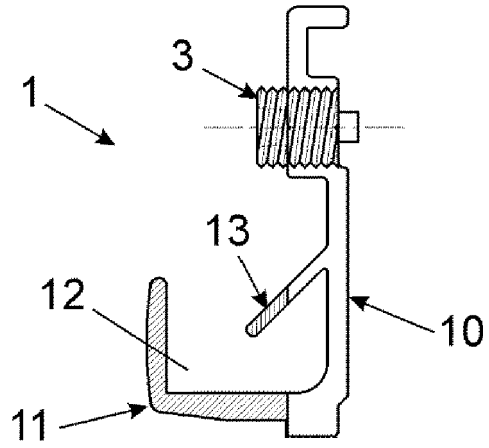

FIG. 11-A

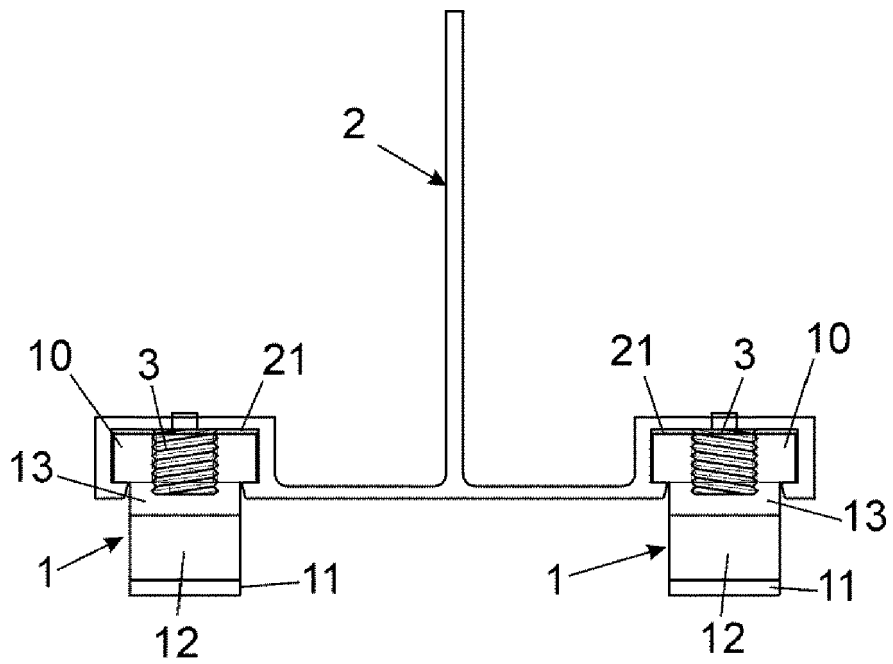

FIG. 11-B

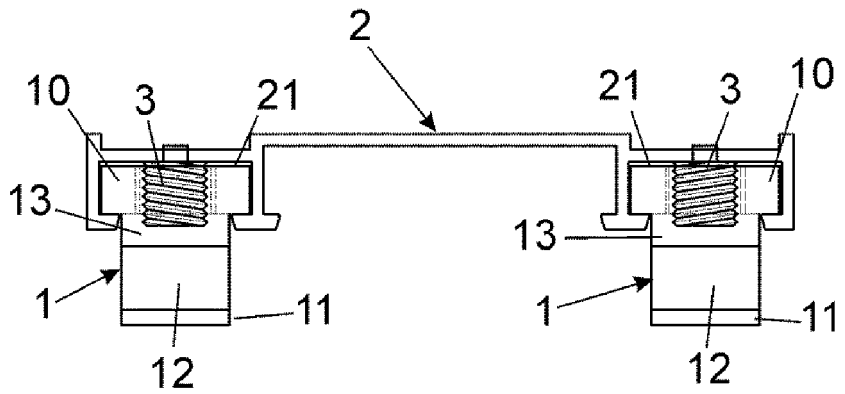

FIG. 12

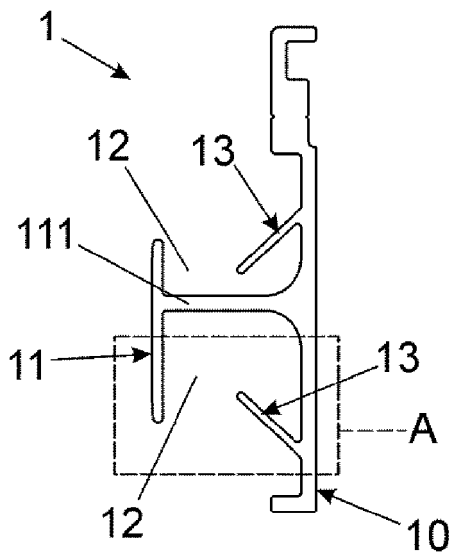
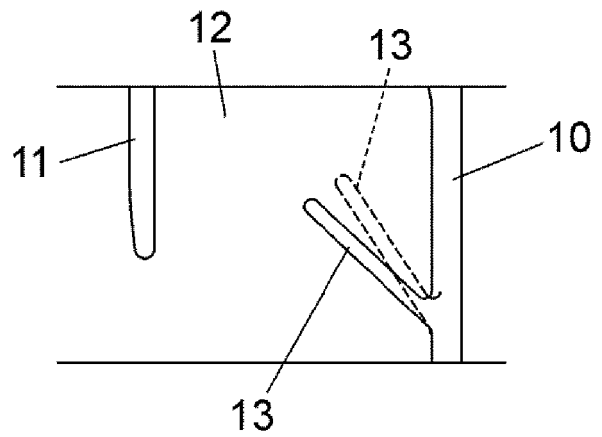

FIG. 13





EUROPEAN SEARCH REPORT

Application Number
EP 18 02 0396

5

10

15

20

25

30

35

40

45

50

55

DOCUMENTS CONSIDERED TO BE RELEVANT			
Category	Citation of document with indication, where appropriate, of relevant passages	Relevant to claim	CLASSIFICATION OF THE APPLICATION (IPC)
X	DE 90 00 858 U1 (WAGNER, PETER) 5 April 1990 (1990-04-05)	1	INV. E04F13/08
A	* page 4, line 15 - page 6, line 27; claim 1; figures 1,2 *	2-12	
A	----- DE 33 29 812 A1 (PROFIL VERTRIEB GMBH [DE]) 28 February 1985 (1985-02-28) * abstract; figures 1-5 *	1-12	
A	----- EP 2 050 897 A2 (BOU & GALI [ES]) 22 April 2009 (2009-04-22) * the whole document *	1	
The present search report has been drawn up for all claims			
Place of search Munich		Date of completion of the search 17 June 2019	Examiner Friedrich, Albert
CATEGORY OF CITED DOCUMENTS X : particularly relevant if taken alone Y : particularly relevant if combined with another document of the same category A : technological background O : non-written disclosure P : intermediate document T : theory or principle underlying the invention E : earlier patent document, but published on, or after the filing date D : document cited in the application L : document cited for other reasons & : member of the same patent family, corresponding document			

EPO FORM 1503 03.02 (P04C01)

**ANNEX TO THE EUROPEAN SEARCH REPORT
ON EUROPEAN PATENT APPLICATION NO.**

EP 18 02 0396

5 This annex lists the patent family members relating to the patent documents cited in the above-mentioned European search report.
The members are as contained in the European Patent Office EDP file on
The European Patent Office is in no way liable for these particulars which are merely given for the purpose of information.

17-06-2019

Patent document cited in search report	Publication date	Patent family member(s)	Publication date
DE 9000858	U1	05-04-1990	NONE

DE 3329812	A1	28-02-1985	NONE

EP 2050897	A2	22-04-2009	EP 2050897 A2 22-04-2009
			ES 1066338 U 01-01-2008

EPO FORM P0459

For more details about this annex : see Official Journal of the European Patent Office, No. 12/82