

(19)



(11)

EP 3 624 154 B1

(12)

EUROPEAN PATENT SPECIFICATION

(45) Date of publication and mention of the grant of the patent:
31.07.2024 Bulletin 2024/31

(51) International Patent Classification (IPC):
H01H 3/26^(2006.01) H01H 71/70^(2006.01)

(21) Application number: **17909561.7**

(52) Cooperative Patent Classification (CPC):
H01H 71/70; H01H 3/26

(22) Date of filing: **08.05.2017**

(86) International application number:
PCT/CN2017/083483

(87) International publication number:
WO 2018/205101 (15.11.2018 Gazette 2018/46)

(54) **MOTOR APPARATUS FOR HIGH VOLTAGE SWITCH DEVICE**

MOTORVORRICHTUNG FÜR HOCHSPANNUNGSSCHALTVORRICHTUNG

APPAREIL DE MOTEUR POUR DISPOSITIF DE COMMUTATION HAUTE TENSION

(84) Designated Contracting States:
AL AT BE BG CH CY CZ DE DK EE ES FI FR GB GR HR HU IE IS IT LI LT LU LV MC MK MT NL NO PL PT RO RS SE SI SK SM TR

• **ZHANG, Xin**
Xiamen, Fujian 361006 (CN)

(43) Date of publication of application:
18.03.2020 Bulletin 2020/12

(74) Representative: **Zimmermann & Partner**
Patentanwälte mbB
Postfach 330 920
80069 München (DE)

(73) Proprietor: **ABB Schweiz AG**
5400 Baden (CH)

(56) References cited:
CN-A- 101 145 454 CN-A- 101 534 020
CN-A- 102 543 500 CN-U- 201 498 912
CN-U- 204 906 000 CN-U- 205 385 429
JP-A- 2011 010 475 US-A- 6 107 702

(72) Inventors:
• **ZHUANG, Zhijian**
Xiamen, Fujian 361021 (CN)
• **LU, Congwen**
Xiamen, Fujian 361009 (CN)

EP 3 624 154 B1

Note: Within nine months of the publication of the mention of the grant of the European patent in the European Patent Bulletin, any person may give notice to the European Patent Office of opposition to that patent, in accordance with the Implementing Regulations. Notice of opposition shall not be deemed to have been filed until the opposition fee has been paid. (Art. 99(1) European Patent Convention).

Description**FIELD**

5 **[0001]** The present disclosure relates to the technical field of mechanical and electrical products, specifically to the technical field of high-voltage switchgear. The present disclosure particularly relates to the technical field of motor equipment acting with a circuit breaker, which is used for operating the circuit breaker and a chassis cart thereof, and storing energy of a spring operating mechanism before operation and so on.

BACKGROUND

10 **[0002]** The current field of power switches, which involves motor operations, usually uses conventional brush motors, such as DC permanent magnet motors or series-excited motors. Based on the technical characteristics of traditional motors, if it is necessary to control the motor, i.e., start, stop or forwardly or reversely rotate the motor, it is usually necessary to use auxiliary electronic and electrical devices, such as relays, rectifier bridges, position switches, and the like. With developing trend of intelligent power grid equipment, it is often necessary to add sensors and communication devices.

15 **[0003]** Based on the important application of motors in the current power switches, there are electric energy storage operation of the spring operating mechanism, electric chassis cart of the removable circuit breaker, turn-on and turn-off operation of the electric ground knife switch, and electric operation of the three-position switch. The present invention will be illustrated by describing the applications of an energy storage motor of the spring operating mechanism and the electric chassis cart of the removable circuit breaker.

20 **[0004]** In the application of the motor in respect of energy storage in the spring mechanism, a typical intelligent circuit breaker structurally includes: a serially-excited motor, a decelerator and a clutch, an electrical limit switch, a Hall current sensor, a Hall voltage sensor and a communication device.

25 **[0005]** In the application of the motor in the electric chassis cart of the removable circuit breaker, a typical intelligent remotely-operable circuit breaker structurally includes: a permanent magnet DC motor, a decelerator, a clutch, an electrical limit switch, a Hall current sensor, a Hall voltage sensor and a motor control and communication device.

30 **[0006]** The above-mentioned existing motor-equipped decelerators and clutches have disadvantages such as complicated structures and unsound functions.

[0007] No matter whether the motor is a traditional permanent magnet DC or serially-excited motor, since it has a mechanical commutation carbon brush, it might have problems such as the Service life of the carbon brush, electrical sparks and inflammability.

35 **[0008]** Furthermore, the motor has problems such as excessive noise and low motor efficiency. If the forward and reverse rotation of the motor, such as in a permanent magnet DC motor, needs to be controlled, the control is achieved with a complex relay control loop to switch the positive and negative polarity of the input of the motor. The control device is complicated structurally and costly.

[0009] US 6 107 702 A discloses a breaker assembly with a control module. A cam operated limit switch operates an electric motor.

40 **[0010]** CN 204 906 000 U discloses an electric chassis truck electric grounding knife-switch control device including a DC brushless motor that is controlled by means of pulse duration modulation.

[0011] JP 2011 010475 A discloses a drive device for a high-load and high-speed drive of a brushless DC motor.

[0012] CN 101 145 454 A discloses a dual power switch transmission apparatus, comprising a motor, a controller, and a reducing mechanism.

45 **[0013]** CN 102 543 500 A discloses a knife switch control apparatus based on a brushless direct current motor, comprising a brushless DC motor, a control unit and an integrated drive unit.

SUMMARY

50 **[0014]** In view of the drawbacks of the motor device for the high-voltage switchgear in the prior art, in accordance with the invention, a motor device for a high-voltage switchgear as set forth in claim 1 is provided. Further embodiments are inter alia disclosed in the dependent claims. In particular the motor device comprises a DC brushless motor, a drive and control device and a decelerator device; the DC brushless motor includes a rotor and a Stator; the rotor is sleeved in the Stator and mounted in a motor housing; both ends of the rotor are respectively sleeved with a rolling bearing, and the bearing is sleeved on a motor drive shaft; the drive and control device comprises a microprocessor, a semiconductor switch and a power supply module for supplying power to the microprocessor; the microprocessor Controls the start, stop, and forward rotation and reverse rotation of the DC brushless motor via the semiconductor switch; the decelerator comprises a gear transmission System composed of a plurality of mutually meshing gears as well as an Output shaft,

and the gear transmission System transmits motion of the motor drive shaft to the Output shaft.

[0015] According to a preferred embodiment of the present disclosure, the motor device further includes a clutch for Controlling coupling and decoupling of the DC brushless motor to and from a motor load.

5 **[0016]** According to a preferred embodiment of the present disclosure, the clutch includes a pin shaft; when the motor device for the high-voltage switchgear is fully stored with energy, the pin shaft disengages from a snap-fitting position with the gear transmission System of the decelerator, thereby causing the Output shaft of the decelerator to disengage from transmission engagement with the clutch transmission System.

[0017] According to a preferred embodiment of the present disclosure, the motor device further includes a power supply cutoff device for cutting off the power supply to the DC brushless motor when the motor device for the high-
10 voltage switchgear is fully stored with energy.

[0018] According to a preferred embodiment of the present disclosure, the clutch further includes an output cam sleeved on the output shaft and being rotatable along with the output shaft; the output cam is provided with an open notch; when the motor device for the high-voltage switchgear is fully stored with energy, and when the cam rotates to the open notch and aligns with a contact wheel of a microswitch, the contact wheel of the microswitch disengages from
15 the output cam at the position of the open notch, thereby cutting off the power supply to the DC brushless motor.

[0019] According to a preferred embodiment of the present disclosure, the motor device further includes a motor input signal controller for inputting a start signal, a stop signal, a forward rotation signal and a reverse rotation signal to the DC brushless motor.

[0020] According to a preferred embodiment of the present disclosure, the motor input signal controller is connected to an external power supply to supply power to the drive and control device; the drive and control device generates a motor control signal of the DC brushless motor based on an external command signal input by the motor input signal controller, and based on a position signal for the circuit breaker, the opened/closed state information for the circuit breaker and an opening/closing signal for a ground knife switch.

[0021] According to a preferred embodiment of the present disclosure, the drive and control device further includes a communication module for transmitting parameters of the DC brushless motor to an upper-layer receiving unit.

[0022] According to a preferred embodiment of the present disclosure, the communication module transmits the parameters of the DC brushless motor by serial communication or controller LAN bus communication.

[0023] According to a preferred embodiment of the present disclosure, the drive and control device includes a power supply module adapted to transform a 24V-250V AC and provide a low voltage DC power supply

30 **[0024]** According to a preferred embodiment of the present disclosure, the drive and control device includes a control module for controlling the semiconductor switch to cut off the power supply to the DC brushless motor when the DC brushless motor is overloaded.

[0025] According to the present invention, the drive and control device includes a monitoring module configured to detect an external command signal input by the motor input signal controller and a position signal for the circuit breaker, the opened/closed state signal for the circuit breaker and a opening/closing signal for the ground knife switch.

[0026] According to the invention, the monitoring module constantly scans the opening/closing signal for the knife switch and the opening/closing signal for the circuit breaker during the operation of the motor device of the high-voltage switchgear. When any of the knife switch and the circuit breaker is not in the open state, the control module immediately stops the motor and locks the signal, thereby locking the system.

40 **[0027]** According to a preferred embodiment of the present disclosure, when the monitoring module detects the external command signal input by the motor input signal controller, the microprocessor judges whether conditions for executing the external command signal action are satisfied; if the conditions are satisfied, the motor executes the corresponding external command signal; if any condition is not satisfied, the motor does not execute the external command signal.

[0028] According to a preferred embodiment of the present disclosure, during the operation of the motor, if the current of the DC brushless motor exceeds a specified threshold, the drive and control device stops the DC brushless motor and the system is locked; if a rotation angle of the DC brushless motor is not varied within a specified period of time, the drive and control device stops the DC brushless motor and the system is blocked; after the signal is locked, the system is in the locked state, and the motor device cannot continue to run and start before being manually unlocked or before being powered on again.

50 **[0029]** The motor device for the high-voltage switchgear according to the present disclosure not only can integrate the drive control and communication module with the body of the motor, but also employs electronic commutation without open flames. The DC brushless motor has a long lifetime and can usually run continuously for more than 5,000 hours. At the same time, the efficiency of the DC brushless motor is very high, usually up to 70%, whereas the traditional motor can only reach 30%-50%. The DC brushless motor has very low vibration and noise and can achieve smooth operation.
55 In terms of speed regulation, the DC brushless motor has natural advantages: the speed may be regulated via voltage as well as frequency.

BRIEF DESCRIPTION OF THE DRAWINGS

[0030]

- 5 FIG. 1 is a structural exploded view showing a motor device for a high-voltage switchgear being applied to an electric chassis cart according to a preferred embodiment of the present disclosure;
- FIG. 2 is a structural schematic diagram of a DC brushless motor of a motor device of a high-voltage switchgear according to a preferred embodiment of the present disclosure.
- 10 FIG. 3 is a structure block diagram showing a drive and control device of a motor device of a high-voltage switchgear for use in an electric chassis cart according to a preferred embodiment of the present disclosure;
- FIG. 4 is a schematic view of a decelerator device of a motor device of a high-voltage switchgear for use in an electric chassis cart according to a preferred embodiment of the present disclosure;
- 15 FIG. 5 is a schematic diagram of input ports of a motor input signal controller of a motor device of a high-voltage switchgear for use in an electric chassis cart according to a preferred embodiment of the present disclosure;
- 20 FIG. 6 is a schematic diagram of a circuit of a drive and control device of a motor device of a high-voltage switchgear for use in an electric chassis cart according to a preferred embodiment of the present disclosure;
- FIG. 7 is a logical block diagram in which a motor device of a high-voltage switchgear for use in an electric chassis cart judges how the motor operates according to an input external command signal, a collected position signal for the circuit breaker, a opened/closed state signal for the circuit breaker and an opening/closing signal for the ground knife switch according to a preferred embodiment of the present disclosure;
- 25 FIG. 8 is a schematic structural view of a motor device of a high-voltage switchgear serving as an energy storage motor of a spring operating mechanism according to a further preferred embodiment of the present disclosure;
- 30 FIG. 9 is a schematic diagram of overall transmission of a decelerator device of a motor device of a high-voltage switchgear serving as an energy storage motor of a spring operating mechanism according to a further preferred embodiment of the present disclosure;
- 35 FIGS. 10A-10B are schematic diagrams of a decelerator device of a motor device of a high-voltage switchgear serving as an energy storage motor according to another preferred embodiment of the present disclosure, wherein FIG. 10A is a perspective view, and FIG. 10B is a cross-sectional view;
- FIG. 11 is a schematic diagram showing structures and state switching of a clutch device of a motor device of a high-voltage switchgear serving as an energy storage motor according to another preferred embodiment of the present disclosure;
- 40 FIGS. 12A-12B are comparative schematic diagrams of a clutch device of a motor device of a high-voltage switchgear serving as an energy storage motor before and after the motor is fully stored with energy according to another preferred embodiment of the present disclosure, wherein FIG. 12A is a schematic diagram of normal operation of the motor before the motor is fully stored with energy, and FIG. 12B is a schematic diagram showing the power supply to the motor being cut off after the motor is fully stored with energy.
- 45

DETAILED DESCRIPTION OF EMBODIMENTS

- 50 [0031] Optional embodiments of the present disclosure will be described in detail below with reference to figures.
- [0032] FIG. 1 is a structural exploded view showing a motor device of a high-voltage switchgear being applied to an electric chassis cart according to a preferred embodiment of the present disclosure. In accordance with this preferred embodiment of the present disclosure, the motor device of the high-voltage switchgear includes a DC brushless motor 20, a drive and control unit 30 and a decelerator device 40.
- 55 [0033] FIG. 2 is a structural schematic diagram of a DC brushless motor of a motor device for a high-voltage switchgear. The DC brushless motor 20 includes a rotor 202 and a stator 203. The rotor 202 is sleeved in the stator 203 and mounted in a motor housing 201. Both ends of the rotor 202 are respectively sleeved with a rolling bearing 204, and the bearing

204 is sleeved on a motor drive shaft 208. An end cover 206 is used to secure the drive and control device 30.

[0034] FIG. 3 is a structural block diagram showing a drive and control device of a motor device for a high-voltage switchgear for use in an electric chassis cart. The drive and control device 30 includes a microprocessor 301, a semiconductor switch 302, and a power supply module 303 for supplying power to the microprocessor 301. The microprocessor 301 controls the start, stop, forward rotation and reverse rotation of the DC brushless motor 20 through the semiconductor switch 302. It should be noted that the semiconductor switch here is a series of semiconductor switches, and one semiconductor switch is illustrated in the figure as an example only. Power supply is the basis for the reliable operation of intelligent modules. Power supply must meet the EMC requirements such as surge, fast transient, radiated electromagnetic field, etc. At the same time, power supply should fully consider different voltage levels, AC and DC conditions, to meet the use under different operating conditions.

[0035] FIG. 4 is a schematic view of a decelerator device of a motor device of a high-voltage switchgear for use in an electric chassis cart. The decelerator 40 includes a gear transmission system 401 comprised of a plurality of intermeshing gears, and an output shaft 402. The gear transmission system 401 transmits motion of the motor drive shaft 208 to the output shaft 402.

[0036] The decelerator end cover 407 has an internal gear and a fixed frame; the gear transmission system 401 is a differential planetary gear train with a three-stage planetary gear transmission stroke, and finally transmits a rotation speed and torque required to the output shaft 402. A cam 403 is mated to the output shaft 402 and is rotatable with the rotation of the output shaft 402. The output shaft 402 has a key groove and a flat key 408 as a mechanical interface for the next stage of transmission.

[0037] FIG. 5 is a schematic diagram of input ports of a motor input signal controller of a motor device of a high-voltage switchgear for use in an electric chassis cart according to a preferred embodiment of the present disclosure, wherein ports 3-5 are for transmitting command signals, ports 6-10 are for transmitting position signals. FIG. 6 is a circuit diagram of any path of ports 3-10.

[0038] FIG. 6 is a schematic diagram of a circuit of a drive and control device of a motor device of a high-voltage switchgear for use in an electric chassis cart. In the figure, SK is a passive mechanical contact for a position signal and an operation command. When the position signal changes or the operation command is applied, SK is closed or opened. U1 is an optocoupler, and functions to isolate strong electricity from weak electricity, and at the same time, converts a voltage signal of the strong electricity into a weak electricity level signal recognizable by the microcontroller; R1 is a current limiting resistor, and provides a turn-on current of about 1mA to the optocoupler when the SK is closed, so a value of R1 should be determined according to a rated voltage of the DC; C1 and R1 form an RC filter circuit, which can filter out an SK jitter or a differential mode interference signal received on an input conductor wire; D1 functions to protect a diode inside the optocoupler. When the DC power supply is connected reversely or the DC negative terminal is subjected to a differential module interference higher than a positive terminal, D1 is turned on and forms a loop, and the diode in the optocoupler has a reverse voltage differential of 0.7V and therefore is protected; R3 and C2 form an RC filter circuit at the output end of the optocoupler to improve the stability of the BI level on the weak electricity side. It should be noted that C1 and C2 cause signal delay, and thus a period of time from input of the position signal and command to recognition of the microcontroller will be increased. The values of C1 and C2 should be adjusted appropriately in practical application.

[0039] The circuit logic table is shown in the following table: wherein 1 indicates that the position or command signal is valid, 0 indicates that the position or command signal is invalid, and X indicates no requirement.

Operation state \ State		Service position	Test position	Knife switch closing	Knife switch opening	Circuit breaker opening
Start pushing in the handcart		0	×	0	1	1
Stop pushing in the handcart	To “service position”	1	×	×	×	×
	“Knife switch opening” fails	×	×	×	0	X
The handcart stops, and C.B opening fails		×	×	×	X	0
Start pulling out the handcart		×	0	0	1	1
Stop pulling out the handcart	To “test position”	×	1	×	×	X
	“Knife switch opening” fails	×	×	×	0	X

[0040] FIG. 7 is a logical block diagram in which a motor device of a high-voltage switchgear for use in an electric chassis cart judges how the motor operates according to an input external command signal and a collected position signal for the circuit breaker, a opened/closed state signal for the circuit breaker and an opening/closing signal for the ground knife according to a preferred embodiment of the present disclosure.

[0041] After the motor is powered on, the system initialization and overvoltage detection are first performed. If the overvoltage is detected and exceeds a certain threshold, the system is in a locked state. Before the unlocking, the motor cannot start normally whatever conditions are satisfied; if the system overvoltage detection passes, the motor is in a standby state, and it is detected in real time whether there is an external command signal input.

[0042] When an external signal is detected (handcart is pushed in or pushed out), it is detected according to the corresponding external signal whether conditions for performing its action are satisfied, and if the conditions are satisfied, the motor executes a corresponding command signal; if any of the conditions is not satisfied, the motor does not act.

[0043] After the motor is started, during the movement (before reaching a corresponding stop position), the motor still constantly scans its condition signal (the ground knife switch opening signal and the circuit breaker opening signal). So long as one of the conditions is not satisfied, the motor will stop immediately and the signal is locked; when the signal is locked, the system is in a locked state, and no matter what conditions are met before manual unlocking, the motor cannot continue to operate and start normally;

[0044] A reset signal is an unlocking signal; after the motor starts, when the motor reaches a corresponding position, namely, the signal conditions satisfy the normal in-position stop, the motor stops and continues to wait for the next command.

[0045] Specific operating principles of the motor device of the high-voltage switchgear of the present disclosure used for the electric chassis cart will be introduced in detail after the detailed description of specific structures of the motor device of the high-voltage switchgear of the present disclosure is completed.

[0046] A further preferred embodiment of the present disclosure will be described below with reference to the figures, wherein the motor device of the high-voltage switchgear is used as an energy storage motor. FIG. 8 is a schematic structural view of a motor device of a high-voltage switchgear serving as an energy storage motor of a spring operating mechanism according to a further preferred embodiment of the present disclosure. The motor device for the high-voltage switchgear includes a DC brushless motor 20, a drive and control device 30, and a decelerator gear 40. The DC brushless motor 20 and the drive and control device 30 are not shown in the figure, and their specific structures may be found from the aforesaid preferred embodiment of the motor device for the high-voltage switchgear for use in an electric chassis cart.

[0047] FIG. 9 is a schematic diagram of overall transmission of a decelerator device of a motor device of a high-voltage switchgear serving as an energy storage motor of a spring operating mechanism according to this embodiment of the present disclosure. As shown in the figure, the energy storage motor employs four-stage transmission, wherein the first stage is through engagement of a worm gear and a worm, and the rotation of the output shaft 208 of the motor is transmitted to a gear transmission system 402; according to an embodiment of the present disclosure, for example, the transmission ratio R1 of the worm gear to the worm in the first stage is 40; at the second stage, the transmission ratio R2 of deceleration transmission is 3.3; at the third stage, the transmission ratio R3 of deceleration transmission is 4; at the fourth stage, the transmission ratio R4 of deceleration transmission is 4.23. The deceleration at the second to fourth

stages is standard spur gear engagement. Finally, the desired rotation speed and torque are transmitted via the output shaft to a corresponding load, namely, a spring operating mechanism.

[0048] FIGS. 10A-10B are structural schematic diagrams of a decelerator device of a motor device of a high-voltage switchgear serving as an energy storage motor according to this preferred embodiment of the present disclosure, wherein FIG. 10A is a perspective view, and FIG. 10B is a cross-sectional view;

[0049] The motor device for the high-voltage switchgear further includes a clutch 50 for controlling the coupling and decoupling of the DC brushless motor 20 and the motor load. The motor load may vary depending on different application situations. For example, in the above two embodiments of the present disclosure, the motor load is a circuit breaker chassis cart in the first preferred embodiment. In the preferred embodiment illustrated in FIGS. 8-12B, the motor load is a spring operating mechanism.

[0050] FIG. 10A further shows a position where the motor device for the high-voltage switchgear is not fully stored with energy. The motor drive shaft 208 of the DC brushless motor transmits via the gear drive system 401, and the final output is the output shaft 402. Wherein, the output shaft 402 rotates less than 360° every time the energy storage device performs an operation. Before the output shaft 402 does not reach a position where the energy is fully stored, the force and torque are transmitted to the output shaft 402 by the cooperation of a pin shaft 502 with an output wheel 406 and then through the output wheel.

[0051] FIG. 11 is a schematic diagram showing structures and state switching of a clutch device of a motor device of a high-voltage switchgear serving as an energy storage motor according to this preferred embodiment of the present disclosure. As shown, the clutch 50 includes a pin shaft 502 and a compression spring 5023. When the load of the motor device for the high-voltage switchgear is fully stored with energy, as shown, the output shaft 402 cannot continue to rotate because the load of the motor device is fully stored with energy; if the motor 20 drives the output wheel 406 to rotate due to inertia or since it is powered off simultaneously, the pin shaft 502 slides along an inner arcuate slot 409. As the pin shaft 502 slides along the inner arcuate slot 409, the arcuate slot 409 snap-fits the pin shaft 502 into a pin shaft catching slot 4061 on the output wheel 406 and compresses the spring 5023. Thus, the pin shaft 502 breaks away from the position where the pin shaft 502 snap-fits with the gear transmission system 401 of the decelerator 40, so that the output shaft 402 of the decelerator 40 breaks away from the transmission engagement with the clutch transmission system 401. The transmission of the DC brushless motor is no longer transmitted to the output shaft 402. When the motor 20 is started again to perform the next energy storage operation, the pin shaft 502 will gradually reset along the inner arc groove 409 under the action of the spring 5023 as the output wheel 406 rotates, until the pin shaft 502 re-snap-fits into the arcuate slot 409, and further drives the output shaft 402 to transmit the corresponding force and torque.

[0052] Furthermore, the motor device of the circuit breaker further includes a power cutoff device for cutting off the power supply to the DC brushless motor 20 when the motor device for the high-voltage switchgear is fully stored with energy. FIGS. 12A-12B are comparative schematic diagrams of a clutch device of a motor device of a high-voltage switchgear serving as an energy storage motor before and after the motor is fully stored with energy according to a preferred embodiment of the present disclosure, wherein FIG. 12A is a schematic diagram of normal operation of the motor before the motor is fully stored with energy.

[0053] FIG. 12B is a schematic diagram showing the power supply to the motor being cut off after the motor is fully stored with energy. The clutch 50 includes an output cam 503 that fits over the output shaft 402 and rotates with the output shaft 402. The output cam 503 is provided with an open notch 5031. When the motor device for the high-voltage switchgear is fully stored with energy, and when the cam 503 rotates to the open notch 5031 and aligns with a contact wheel 9031 of a microswitch 903, the contact wheel 9031 of the microswitch 903 disengages from the cam 503 at the position of the open notch 5031, thereby cutting off the power supply to the DC brushless motor 20.

[0054] Returning to an embodiment in which the motor device for the high-voltage switchgear of the present disclosure is used for an electric chassis cart, specific operating principles will be described below.

[0055] The motor device for the high-voltage switchgear further includes a motor input signal controller 60 for inputting a start signal, a stop signal, a forward rotation signal and a reverse rotation signal to the DC brushless motor 20. The motor input signal controller 60 is connected to an external power supply to supply power to the drive and control device 30; the drive and control device 30 generates the motor control signal of the DC brushless motor 20 based on an external command signal input by the motor input signal controller 60, and based on the position signal for the circuit breaker, the opened/closed state information for the circuit breaker and the opening/closing signal for the ground knife switch.

[0056] Referring to the structure block diagram of the drive and control device of the motor device for the high-voltage switchgear for use in an electric chassis cart, as shown in FIG. 3, the drive and control device 30 further includes a communication module 305 for transmitting parameters of the DC brushless motor 20 to an upper-layer receiving unit. The communication module 305 transmits the parameters of the DC brushless motor 20 by serial communication or controller LAN bus communication. The communication module 305 adopts a galvanic isolated RS485 mode or CAN field bus mode at the physical layer, and the communication protocol supports Modbus to transmit motor operation data and curves.

[0057] The drive and control device 30 further includes a power supply module 303 adapted to transform a 24V-250V

AC and provide a low voltage DC power supply. The drive and control device 30 further includes a control module 307 for controlling the semiconductor switch 302 to cut off the power supply to the DC brushless motor 20 when the DC brushless motor 20 is overloaded. A monitoring module 308 is configured to detect the external command signal input by the motor input signal controller 60 and the position signal for the circuit breaker, the opened/closed state signal for the circuit breaker and the opening/closing signal for the ground knife switch. The monitoring module 308 constantly scans the opening/closing signal for the ground knife switch and the opening/closing signal for the circuit breaker during the operation of the motor device for the high-voltage switchgear. When either of the knife switch and the circuit breaker is not in the open state, the control module 307 immediately stops the motor and locks the signal, thereby locking the system. When the monitoring module 308 detects the external command signal input by the motor input signal controller 60, the handcart is pushed in or pushed out, and the microprocessor 301 judges whether conditions for executing the external command signal action are satisfied. If the conditions are satisfied, the motor executes the corresponding external command signal; if any of the conditions is not satisfied, the motor does not execute the external command signal. The control module 307 employs an MCU with strong anti-interference performance and a control current to perform closed-loop motor control.

[0058] For example, in a specific operation example, the command given by the user is that the handcart is pushed in, at this time it is detected whether the circuit breaker is opened, whether the knife switch is opened and whether the circuit breaker is at a service position. If the three conditions are satisfied at the same time, the motor performs the operation of pushing in the handcart. Otherwise, if any of the conditions is not satisfied, the motor will not perform the operation. For example, the command given by the user is that the handcart is pulled out, at this time it is detected whether the circuit breaker is opened, whether the knife switch is opened and whether the circuit breaker is at a test position. If the three conditions are satisfied at the same time, the motor performs the operation of pulling out the handcart. Otherwise, if any of the conditions is not satisfied, the motor will not perform the operation

[0059] The monitoring module 308 also constantly monitors the operating state of the DC brushless motor during operation of the motor. If the current of the DC brushless motor exceeds a specified threshold, e.g., the motor operates at a 24V DC and the current exceeds 2.5A, the drive and control device 30 stops the motor and the system is locked. Again for example, in a DC brushless motor, there is a Hall position sensor for detecting the rotational position of the motor; if a rotation angle of the motor is not varied within a specified period of time, for example, if the sensor does not detect the motor angle being varied within 2 seconds, a fault might occur or the motor is blocked, and the drive and control device 30 stops the motor and the system is blocked.

[0060] After the signal is locked, the system is in the locked state, and it cannot continue to run and start before being manually unlocked or before being powered on again. At this time, the motor cannot operate regardless of pressing operation buttons such as a push-in button and a push-out button.

[0061] The motor device of the present disclosure is free from the complexity of the traditional motor intelligent system. By virtue of natural advantages of the DC brushless motors, the motor device not only can integrate the drive control and communication module with the body of the motor, but also employs electronic commutation without open flames. The DC brushless motor has a long lifetime and can usually run continuously for more than 5,000 hours. At the same time, the efficiency of the DC brushless motor is very high, usually up to 70%, whereas the traditional motor can only reach 30%-50%. The DC brushless motor has very low Vibration and noise and can achieve smooth Operation. In terms of speed regulation, the DC brushless motor has natural advantages: the speed may be regulated via voltage as well as frequency.

[0062] Certainly, the motor for the intelligent circuit breaker based on the DC brushless motor not only naturally inherits various advantages of the brushless motor, but also has a simple and compact structure, is easy to maintain, and greatly reduces the costs of the whole System while improving the reliability of the Overall System, as compared with the motor intelligent System used in the conventional breaker.

[0063] The motor device for the high-voltage switchgear provided by the present disclosure first introduces a DC brushless motor, and secondly, employs an integrated drive and control device, and integrates various functions such as driving, protection, communication, power supply control and power supply. Furthermore, the motor device for the high-voltage switchgear provided by the present disclosure has a decelerator device which is novel and reasonable in design and simple in structure. The design of the clutch is also different from a conventional one, it may not only control engagement and disengagement of the drive of the DC brushless motor, but also have a load. When the motor device is fully stored with energy, it may automatically disengage from the transmission System. The further optimized design of the clutch may also enable automatic cutoff of the power supply of the DC brushless motor as needed.

Claims

1. A motor device of a high-voltage switchgear,

comprising a DC brushless motor (20), wherein the motor device further comprises a drive and control device (30) and a decelerator device (40);

the DC brushless motor (20) includes a rotor (202) and a stator (203); the rotor (202) is sleeved in the stator (203) and mounted in a motor housing (201); both ends of the rotor (202) are respectively sleeved with a rolling bearing (204), and the bearing (204) is sleeved on a motor drive shaft (208);

the drive and control device (30) comprises a microprocessor (301), a semiconductor switch (302) and a power supply module (303) for supplying power to the microprocessor (301); the microprocessor (301) is adapted to control the start, stop, and forward rotation and reverse rotation of the DC brushless motor (20) via the semiconductor switch (302);

the decelerator (40) comprises a gear transmission system (401) composed of a plurality of mutually meshing gears as well as an output shaft (402), and the gear transmission system (401) is adapted to transmit motion of the motor drive shaft (208) to the output shaft (402),

wherein the drive and control device (30) includes a monitoring module (309) configured to detect an external command signal input by the motor input signal controller (60), and a position signal for the circuit breaker, an opened/closed state signal for the circuit breaker and an opening/closing signal for a ground knife switch, wherein the monitoring module (309) is adapted to constantly scan the opening/closing signal for the knife switch and the opening/closing signal for the circuit breaker during the operation of the motor device for the high-voltage switchgear.

2. The motor device of a high-voltage switchgear according to claim 1, wherein the motor device further includes a clutch (50) for controlling coupling and decoupling of the DC brushless motor (20) to and from a motor load.

3. The motor device of a high-voltage switchgear according to claim 2, wherein

the clutch (50) includes a pin shaft (502);

when the motor device of the high-voltage switchgear is fully stored with energy, the pin shaft (502) disengages from a snap-fitting position with the gear transmission system (401) of the decelerator (40), thereby causing the output shaft (402) of the decelerator (40) to disengage from transmission engagement with the clutch transmission system (401).

4. The motor device of a high-voltage switchgear according to claim 1, wherein the motor device further includes a power supply cutoff device for cutting off the power supply to the DC brushless motor (20) when the motor device of the high-voltage switchgear is fully stored with energy.

5. The motor device of a high-voltage switchgear according to claim 2, wherein

the clutch (50) further includes an output cam (503) sleeved on the output shaft (402) and being rotatable along with the output shaft (402);

the output cam (503) is provided with an open notch (5031), so that when the motor device of the high-voltage switchgear is fully stored with energy, and

when the cam (503) rotates to the open notch (5031) and aligns with a contact wheel (9031) of a microswitch (903), the contact wheel (9031) of the microswitch (903) disengages from the output cam (503) at the position of the open notch (5031), thereby cutting off the power supply to the DC brushless motor (20).

6. The motor device of a high-voltage switchgear according to claim 1, wherein the motor device further includes a motor input signal controller (60) for inputting a start signal, a stop signal, a forward rotation signal and a reverse rotation signal to the DC brushless motor (20).

7. The motor device of a high-voltage switchgear according to claim 6, wherein

the motor input signal controller (60) is connected to an external power supply to supply power to the drive and control device (30);

the drive and control device (30) generates a motor control signal of the DC brushless motor (20) based on an external command signal input by the motor input signal controller (60), and based on a position signal for a circuit breaker, the opened/closed state information for the circuit breaker and an opening/closing signal of a ground knife switch.

8. The motor device of a high-voltage switchgear according to any of claims 1-5, wherein the drive and control device (30) further includes a communication module (305) for transmitting parameters of the DC brushless motor (20) to an upper-layer receiving unit.
- 5 9. The motor device of a high-voltage switchgear according to claim 8, wherein the communication module (305) transmits the parameters of the DC brushless motor (20) by serial communication or controller LAN bus communication.
- 10 10. The motor device of a high-voltage switchgear according to claim 8, wherein the drive and control device (30) includes a power supply module adapted to transform a 24V-250V AC and provide a low voltage DC power supply.
- 15 11. The motor device of a high-voltage switchgear according to claim 8, wherein the drive and control device (30) includes a control module (307) for controlling the semiconductor switch (308) to cut off the power supply to the DC brushless motor (20) when the DC brushless motor (20) is overloaded.
- 20 12. The motor device of a high-voltage switchgear according to claim 1, wherein when either of the knife switch and the circuit breaker is not in the open state, the control module (307) is adapted to immediately stop the motor and locks the signal, thereby locking the system.
- 25 13. The motor device of a high-voltage switchgear according to claim 1, wherein when the monitoring module (309) detects the external command signal input by the motor input signal controller (60), the microprocessor (301) is adapted to judge whether conditions for executing the external command signal action are satisfied; if the conditions are satisfied, the motor is adapted to execute the corresponding external command signal; if any of the conditions is not satisfied, the motor is adapted to not execute the external command signal.
- 30 14. The motor device of a high-voltage switchgear according to claim 1, wherein during the operation of the motor: if the current of the DC brushless motor exceeds a specified threshold, the drive and control device (30) is adapted to stop the DC brushless motor (20) and the system is locked; if a rotation angle of the DC brushless motor is not varied within a specified period of time, the drive and control device (30) is adapted to stop the DC brushless motor (20) and the system is locked; 35 after the signal is locked, the system is in the locked state, and the motor device is adapted to not continue to run and start before being manually unlocked or before being powered on again.

Patentansprüche

- 40 1. Motorvorrichtung eines Hochspannungsschaltgeräts, mit einem bürstenlosen Gleichstrommotor (20), wobei die Motorvorrichtung ferner eine Antriebs- und Steuervorrichtung (30) und eine Abbremsvorrichtung (40) umfasst; 45 der bürstenlose Gleichstrommotor (20) einen Rotor (202) und einen Stator (203) aufweist; der Rotor (202) im Stator (203) gelagert und in einem Motorgehäuse (201) montiert ist; beide Enden des Rotors (202) jeweils mit einem Wälzlager (204) gelagert sind und das Lager (204) auf einer Motorantriebswelle (208) gelagert ist; die Antriebs- und Steuervorrichtung (30) einen Mikroprozessor (301), einen Halbleiterschalter (302) und ein Stromversorgungsmodul (303) zur Versorgung des Mikroprozessors (301) mit Strom umfasst; der Mikroprozessor (301) so beschaffen ist, dass er den Start, den Stopp sowie die Vorwärts- und Rückwärtsdrehung des bürstenlosen Gleichstrommotors (20) über den Halbleiterschalter (302) steuert; 50 die Abbremsvorrichtung (40) ein Getriebeübertragungssystem (401) umfasst, das aus einer Vielzahl von ineinandergreifenden Zahnrädern sowie einer Ausgangswelle (402) besteht, und das Getriebeübertragungssystem (401) dazu ausgelegt ist, die Bewegung der Motorantriebswelle (208) auf die Ausgangswelle (402) zu übertragen, wobei die Antriebs- und Steuervorrichtung (30) ein Überwachungsmodul (309) aufweist, das so konfiguriert ist, dass es ein externes Befehlssignal, das von der Motoreingangssignalsteuerung (60) eingegeben wird, und ein Positionssignal für den Leistungsschalter, ein Signal für den geöffneten/geschlossenen Zustand des Leistungsschalters und ein Öffnungs-/Schließsignal für einen Erdungsmesserschalter erfasst; 55

EP 3 624 154 B1

wobei das Überwachungsmodul (309) dazu ausgelegt ist, das Öffnungs-/Schließsignal für den Messerschalter und das Öffnungs-/Schließsignal für den Leistungsschalter während des Betriebs der Motorvorrichtung für die Hochspannungsschaltanlage ständig abzufragen.

- 5 **2.** Motorvorrichtung eines Hochspannungsschaltgeräts nach Anspruch 1, wobei
die Motorvorrichtung ferner eine Kupplung (50) zur Steuerung der Ankopplung und Abkopplung des bürstenlosen
Gleichstrommotors (20) an und von einer Motorlast umfasst.
- 10 **3.** Motorvorrichtung eines Hochspannungsschaltgeräts nach Anspruch 2, wobei
die Kupplung (50) eine Bolzenwelle (502) umfasst;
wenn die Motorvorrichtung des Hochspannungsschaltgeräts vollständig mit Energie gespeichert ist, löst sich
die Stiftwelle (502) aus einer Einrastposition mit dem Getriebeübertragungssystem (401) des Bremsers (40),
wodurch die Ausgangswelle (402) des Bremsers (40) aus dem Getriebeeingriff mit dem Getriebeübertragungs-
system (401) gelöst wird.
- 15 **4.** Motorvorrichtung eines Hochspannungsschaltgeräts nach Anspruch 1, wobei
die Motorvorrichtung ferner eine Stromversorgungsunterbrechungsvorrichtung zum Unterbrechen der Stromversor-
gung des bürstenlosen Gleichstrommotors (20) umfasst, wenn die Motorvorrichtung der Hochspannungsschaltan-
lage vollständig mit Energie versorgt ist.
- 20 **5.** Motorvorrichtung einer Hochspannungsschaltanlage nach Anspruch 2, wobei
die Kupplung (50) ferner einen Ausgangsnocken (503) aufweist, der auf der Ausgangswelle (402) gelagert und
zusammen mit der Ausgangswelle (402) drehbar ist;
der Ausgangsnocken (503) mit einer offenen Kerbe (5031) versehen ist, so dass, wenn die Motorvorrichtung
des Hochspannungsschaltgeräts vollständig mit Energie versorgt wird und
wenn sich die Nocke (503) zu der offenen Kerbe (5031) dreht und mit einem Kontaktrad (9031) eines Mikro-
schalters (903) fluchtet, das Kontaktrad (9031) des Mikroschalters (903) an der Position der offenen Kerbe
(5031) von der Ausgangsnocke (503) ausrastet und dadurch die Stromversorgung des bürstenlosen Gleich-
strommotors (20) unterbricht.
- 25 **6.** Motorvorrichtung einer Hochspannungsschaltanlage nach Anspruch 1, wobei
die Motorvorrichtung ferner eine Motoreingangssignalsteuerung (60) zum Eingeben eines Startsignals, eines Stopp-
signals, eines Vorwärtsdrehungssignals und eines Rückwärtsdrehungssignals in den bürstenlosen Gleichstrommo-
tor (20) umfasst.
- 30 **7.** Motorvorrichtung einer Hochspannungsschaltanlage nach Anspruch 6, wobei
die Motoreingangssignalsteuerung (60) mit einer externen Stromversorgung verbunden ist, um die Antriebs-
und Steuervorrichtung (30) mit Strom zu versorgen;
die Antriebs- und Steuervorrichtung (30) ein Motorsteuersignal des bürstenlosen Gleichstrommotors (20) auf
der Grundlage eines externen Befehlssignals erzeugt, das von der Motoreingangssignalsteuerung (60) einge-
geben wird, und
basierend auf einem Positionssignal für einen Leistungsschalter, auf Information über den geöffneten/geschlos-
senen Zustand des Leistungsschalters und auf einem Öffnungs-/Schließsignal eines Erdungsmessers.
- 35 **8.** Motorvorrichtung einer Hochspannungsschaltanlage nach einem der Ansprüche 1-5, wobei
die Antriebs- und Steuervorrichtung (30) ferner ein Kommunikationsmodul (305) zum Übertragen von Parametern
des bürstenlosen Gleichstrommotors (20) an eine übergeordnete Empfangseinheit aufweist.
- 40 **9.** Motorvorrichtung einer Hochspannungsschaltanlage nach Anspruch 8, wobei
das Kommunikationsmodul (305) die Parameter des bürstenlosen Gleichstrommotors (20) durch serielle Kommu-
nikation oder Controller-LAN-Bus-Kommunikation überträgt.
- 45 **10.** Motorvorrichtung einer Hochspannungsschaltanlage nach Anspruch 8, wobei
die Antriebs- und Steuervorrichtung (30) ein Stromversorgungsmodul aufweist, das ausgelegt ist, einen 24V-250V
Wechselstrom umzuwandeln und eine Niederspannungs-Gleichstromversorgung bereitzustellen.
- 50
- 55

11. Motorvorrichtung einer Hochspannungsschaltanlage nach Anspruch 8, wobei die Antriebs- und Steuervorrichtung (30) ein Steuermodul (307) zur Steuerung des Halbleiterschalters (308) aufweist, um die Stromversorgung des bürstenlosen Gleichstrommotors (20) zu unterbrechen, wenn der bürstenlose Gleichstrommotor (20) überlastet ist.

5

12. Motorvorrichtung einer Hochspannungsschaltanlage nach Anspruch 1, wobei das Steuermodul (307) so ausgelegt ist, dass es den Motor sofort stoppt und das Signal sperrt, wenn sich der Messerschalter oder der Leistungsschalter nicht im offenen Zustand befindet, wodurch das System gesperrt wird.

10 13. Motorvorrichtung einer Hochspannungsschaltanlage nach Anspruch 1, wobei
wenn das Überwachungsmodul (309) das von der Motoreingangssignalsteuerung (60) eingegebene externe Befehlssignal detektiert, der Mikroprozessor (301) ausgelegt ist, zu beurteilen, ob die Bedingungen für die Ausführung der externen Befehlssignalaktion erfüllt sind;
15 wenn die Bedingungen erfüllt sind, der Motor ausgelegt ist, das entsprechende externe Befehlssignal ausführen;
wenn eine der Bedingungen nicht erfüllt ist, der Motor ausgelegt ist, dass er das externe Befehlssignal nicht ausführt.

20 14. Motorvorrichtung einer Hochspannungsschaltanlage nach Anspruch 1, wobei während des Betriebs des Motors:
wenn der Strom des bürstenlosen Gleichstrommotors einen spezifizierten Schwellenwert übersteigt, die Antriebs- und Steuervorrichtung (30) so ausgelegt ist, dass sie den bürstenlosen Gleichstrommotor (20) anhält und das System gesperrt wird;
wenn ein Drehwinkel des bürstenlosen Gleichstrommotors nicht innerhalb einer spezifizierten Zeitspanne verändert wird, ist die Antriebs- und Steuervorrichtung (30) so ausgelegt, dass sie den bürstenlosen Gleichstrommotor (20) anhält und das System gesperrt wird;
25 nachdem das Signal verriegelt wurde, befindet sich das System im verriegelten Zustand, und die Motorvorrichtung ist so ausgelegt, dass sie nicht weiterläuft und startet, bevor sie manuell entriegelt oder wieder eingeschaltet wird.

30

Revendications

1. Dispositif moteur d'un appareillage de commutation haute tension,

35

comprenant un moteur à CC sans balai (20), dans lequel le dispositif moteur comprend en outre un dispositif d'entraînement et de commande (30) et un dispositif ralentisseur (40) ;

40

le moteur à CC sans balai (20) inclut un rotor (202) et un stator (203) ; le rotor (202) est emmanché dans le stator (203) et monté dans un carter de moteur (201) ; les deux extrémités du rotor (202) sont respectivement emmanchées avec un palier de roulement (204), et le palier (204) est emmanché sur un arbre d'entraînement de moteur (208) ;

45

le dispositif d'entraînement et de commande (30) comprend un microprocesseur (301), un commutateur à semi-conducteur (302) et un module d'alimentation en électricité (303) pour effectuer l'alimentation en électricité au microprocesseur (301) ; le microprocesseur (301) est adapté pour commander le démarrage, l'arrêt, et la rotation en sens avant et la rotation en sens arrière du moteur à CC sans balai (20) par l'intermédiaire du commutateur à semi-conducteur (302) ;

50

le ralentisseur (40) comprend un système de transmission à engrenages (401) composé d'un pluralité d'engrenages à engrènement mutuel ainsi qu'un arbre de sortie (402), et le système de transmission à engrenages (401) est adapté pour transmettre un mouvement de l'arbre d'entraînement de moteur (208) à l'arbre de sortie (402),

55

dans lequel le dispositif d'entraînement et de commande (30) inclut un module de surveillance (309) configuré pour détecter un signal d'instruction externe entré par l'unité de commande de signal d'entrée de moteur (60), et un signal de position pour le disjoncteur, un signal d'état ouvert/fermé pour le disjoncteur et un signal d'ouverture/de fermeture pour un commutateur à lame de terre,

dans lequel le module de surveillance (309) est adapté pour balayer de façon constante le signal d'ouverture/de fermeture pour le commutateur à lame et le signal d'ouverture/de fermeture pour le disjoncteur durant le fonctionnement du dispositif moteur pour l'appareillage de commutation haute tension.

EP 3 624 154 B1

2. Dispositif moteur d'un appareillage de commutation haute tension selon la revendication 1, dans lequel le dispositif moteur inclut en outre un embrayage (50) pour commander le couplage et le découplage du moteur à CC sans balai (20) à une charge de moteur et à partir de cette dernière.
- 5 3. Dispositif moteur d'un appareillage de commutation haute tension selon la revendication 2, dans lequel
- l'embrayage (50) inclut un arbre à broche (502) ;
lorsque le stockage en énergie du dispositif moteur de l'appareillage de commutation haute tension est plein,
10 l'arbre à broche (502) se sépare d'une position d'ajustement par encliquetage avec le système de transmission à engrenages (401) du ralentisseur (40), ainsi faisant en sorte que l'arbre de sortie (402) du ralentisseur (40) quitte l'enclenchement de transmission avec le système de transmission à embrayage (401).
4. Dispositif moteur d'un appareillage de commutation haute tension selon la revendication 1, dans lequel le dispositif moteur inclut en outre un dispositif de coupure d'alimentation en électricité pour couper l'alimentation en électricité au moteur à CC sans balai (20) lorsque le stockage en énergie du dispositif moteur de l'appareillage de commutation haute tension est plein.
- 15 5. Dispositif moteur d'un appareillage de commutation haute tension selon la revendication 2, dans lequel
- 20 l'embrayage (50) inclut en outre une came de sortie (503) emmanchée sur l'arbre de sortie (402) et rotative conjointement avec l'arbre de sortie (402) ;
la came de sortie (503) est pourvue d'une entaille ouverte (5031), pour que, lorsque le stockage en énergie du dispositif moteur de l'appareillage de commutation haute tension est plein, et
25 lorsque la came (503) entre en rotation jusqu'à l'entaille ouverte (5031) et s'aligne avec une roue de contact (9031) d'un microrupteur (903), la roue de contact (9031) du microrupteur (903) se sépare de la came de sortie (503) à la position de l'entaille ouverte (5031), ainsi coupant l'alimentation en électricité au moteur à CC sans balai (20).
6. Dispositif moteur d'un appareillage de commutation haute tension selon la revendication 1, dans lequel le dispositif moteur inclut en outre une unité de commande de signal d'entrée de moteur (60) pour entrer un signal de démarrage, un signal d'arrêt, un signal de rotation en sens avant et un signal de rotation en sens arrière dans le moteur à CC sans balai (20).
- 30 7. Dispositif moteur d'un appareillage de commutation haute tension selon la revendication 6, dans lequel
- 35 l'unité de commande de signal d'entrée de moteur (60) est connectée à une alimentation en électricité externe pour effectuer l'alimentation en électricité au dispositif d'entraînement et de commande (30) ;
le dispositif d'entraînement et de commande (30) génère un signal de commande de moteur du moteur à CC sans balai (20) sur la base d'un signal d'instruction externe entré par l'unité de commande de signal d'entrée de moteur (60), et
40 sur la base d'un signal de position pour un disjoncteur, des informations d'état ouvert/fermé pour le disjoncteur et d'un signal d'ouverture/de fermeture d'un commutateur à lame de terre.
8. Dispositif moteur d'un appareillage de commutation haute tension selon l'une quelconque des revendications 1 à 5, dans lequel le dispositif d'entraînement et de commande (30) inclut en outre un module de communication (305) pour transmettre des paramètres du moteur à CC sans balai (20) à une unité de réception de couche supérieure.
- 45 9. Dispositif moteur d'un appareillage de commutation haute tension selon la revendication 8, dans lequel le module de communication (305) transmet les paramètres du moteur à CC sans balai (20) par communication série ou communication bus LAN d'unité de commande.
- 50 10. Dispositif moteur d'un appareillage de commutation haute tension selon la revendication 8, dans lequel le dispositif d'entraînement et de commande (30) inclut un module d'alimentation en électricité adapté pour transformer un CA de 24 V à 250 V et fournir une alimentation en électricité CC basse tension.
- 55 11. Dispositif moteur d'un appareillage de commutation haute tension selon la revendication 8, dans lequel le dispositif d'entraînement et de commande (30) inclut un module de commande (307) pour commander le com-

EP 3 624 154 B1

mutateur à semi-conducteur (308) pour couper l'alimentation en électricité au moteur à CC sans balai (20) lorsque le moteur à CC sans balai (20) est surchargé.

5 12. Dispositif moteur d'un appareillage de commutation haute tension selon la revendication 1, dans lequel lorsque l'un ou l'autre du commutateur à lame et du disjoncteur n'est pas dans l'état ouvert, le module de commande (307) est adapté pour immédiatement arrêter le moteur et bloquer le signal, ainsi bloquant le système.

10 13. Dispositif moteur d'un appareillage de commutation haute tension selon la revendication 1, dans lequel lorsque le module de surveillance (309) détecte le signal d'instruction externe entré par l'unité de commande de signal d'entrée de moteur (60), le microprocesseur (301) est adapté pour déterminer si des conditions pour exécuter l'action de signal d'instruction externe sont respectées ;
si les conditions sont respectées, le moteur est adapté pour exécuter le signal d'instruction externe correspondant ;
15 si l'une quelconque des conditions n'est pas respectée, le moteur est adapté pour ne pas exécuter le signal d'instruction externe.

20 14. Dispositif moteur d'un appareillage de commutation haute tension selon la revendication 1, dans lequel, durant le fonctionnement du moteur :

si le courant du moteur à CC sans balai dépasse un seuil spécifié, le dispositif d'entraînement et de commande (30) est adapté pour arrêter le moteur à CC sans balai (20) et le système est bloqué ;
si un angle de rotation du moteur à CC sans balai n'est pas varié au sein d'une période spécifiée, le dispositif d'entraînement et de commande (30) est adapté pour arrêter le moteur à CC sans balai (20) et le système est
25 bloqué ;
après que le signal est bloqué, le système est dans l'état bloqué, et le dispositif moteur est adapté pour ne pas continuer de marcher et démarrer avant d'être manuellement débloqué ou avant d'être allumé à nouveau.

30

35

40

45

50

55

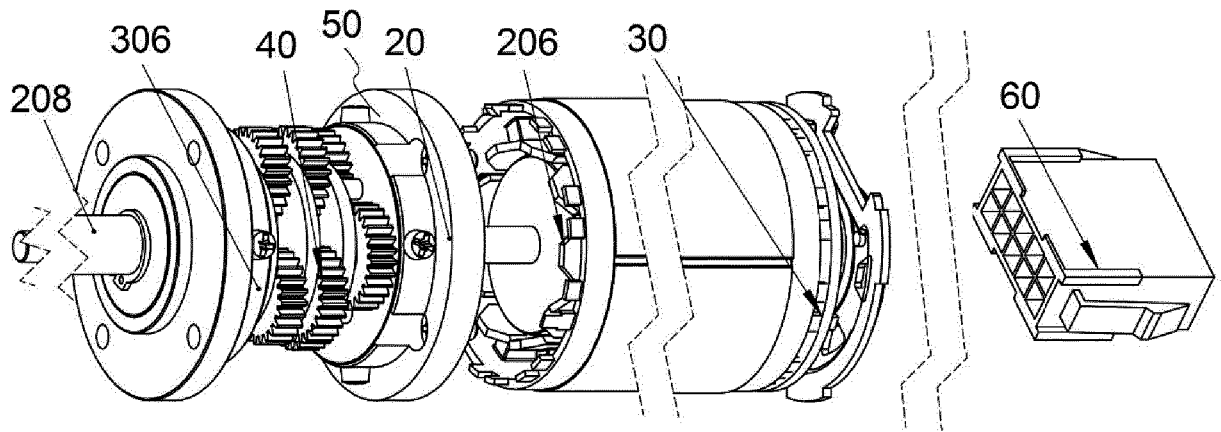

FIG.1

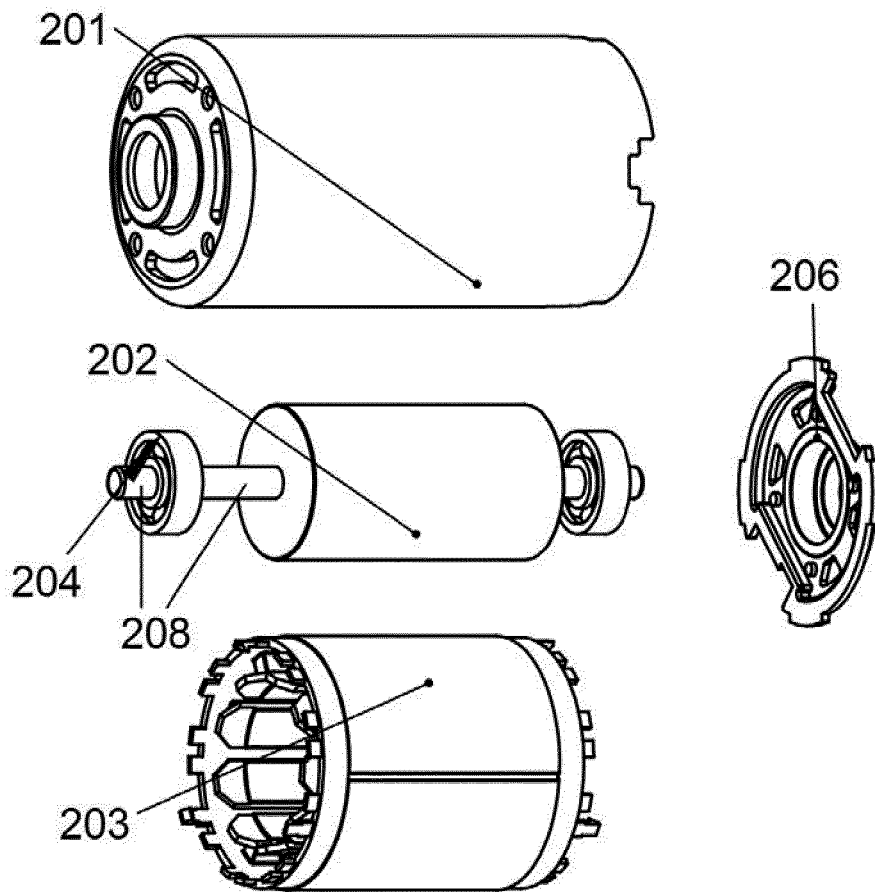

FIG.2

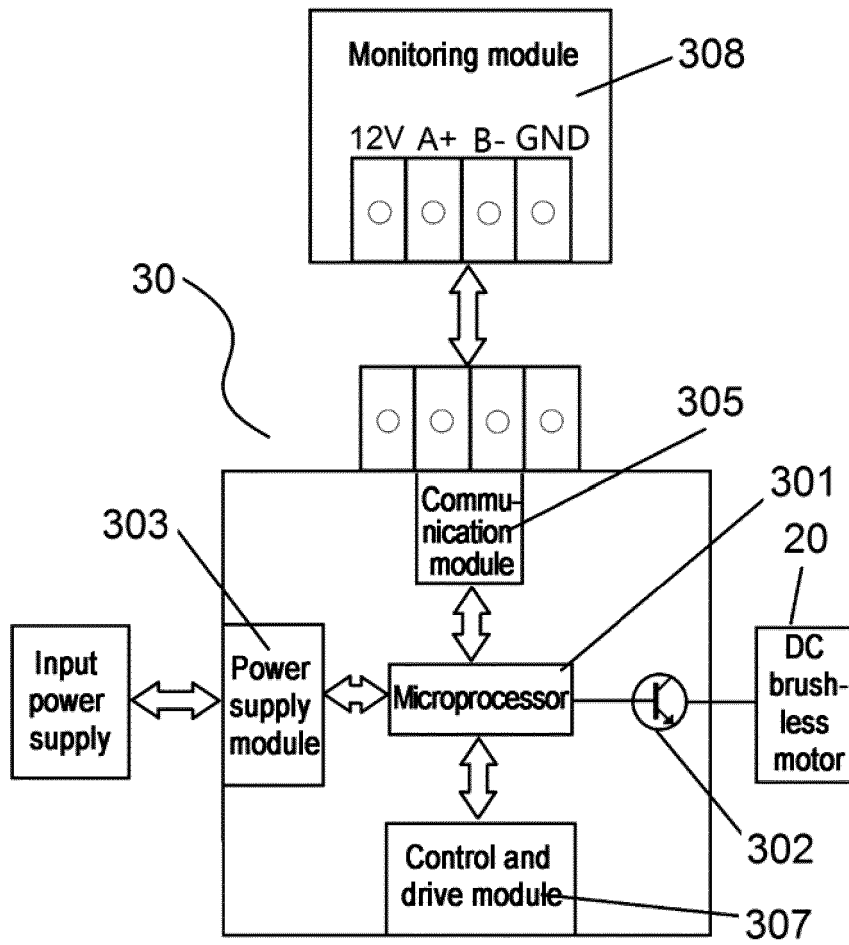

FIG.3

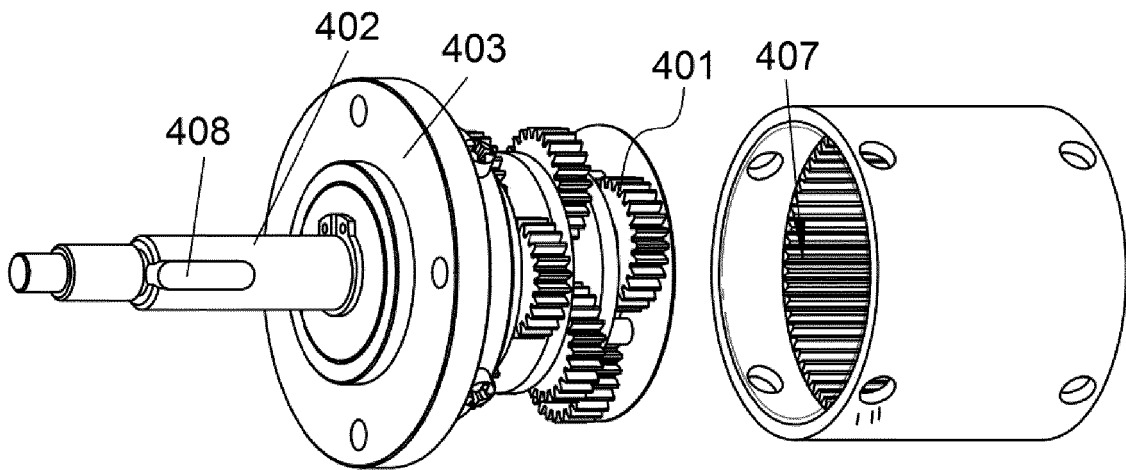

FIG.4

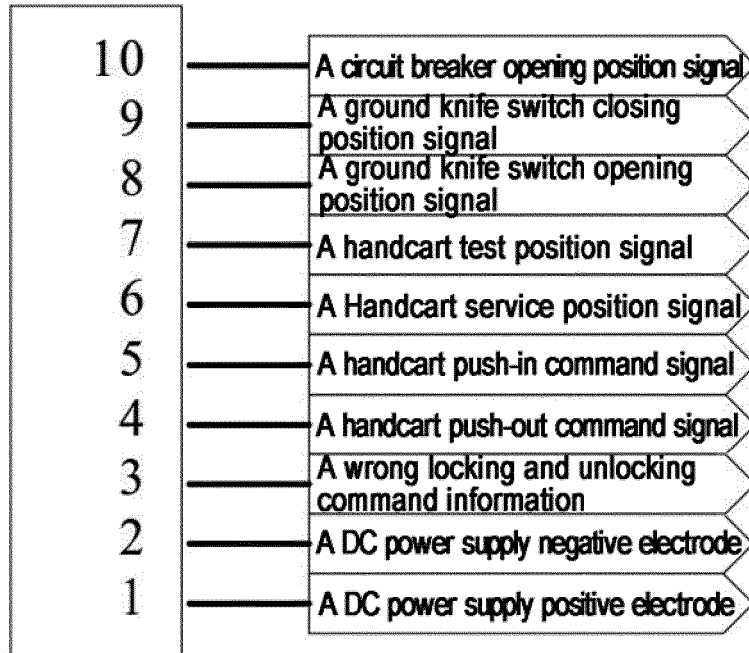

FIG.5

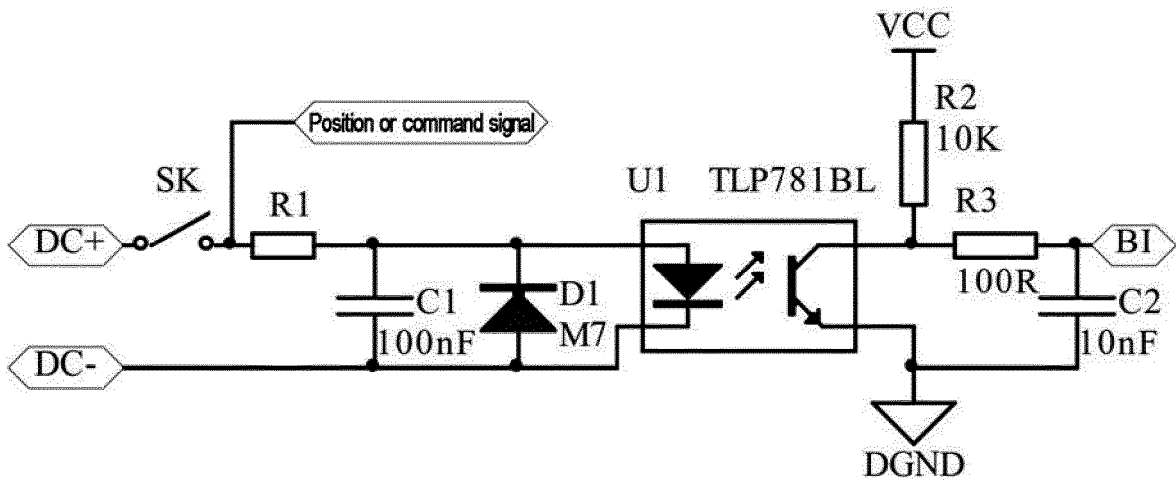

FIG.6

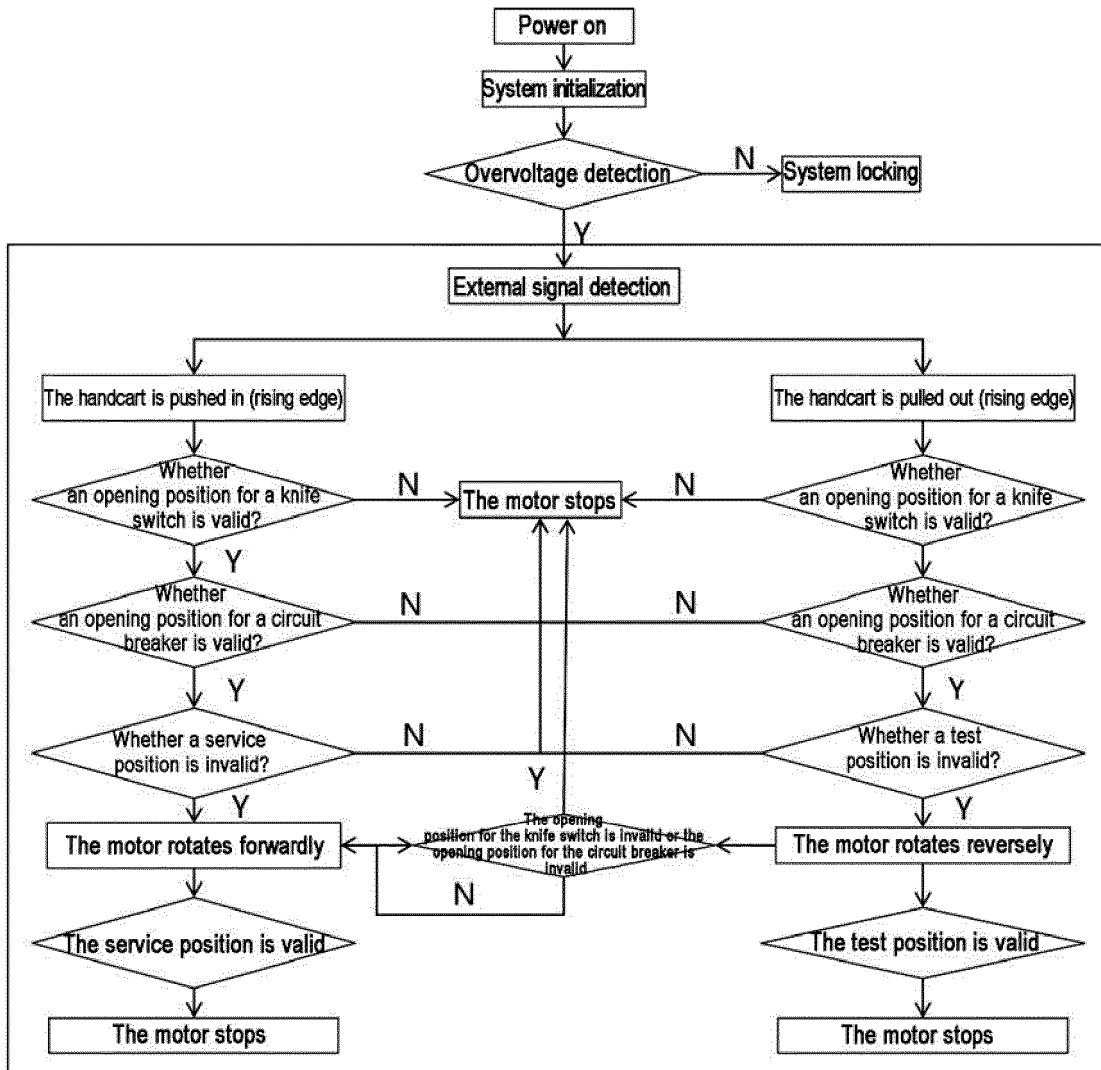

FIG. 7

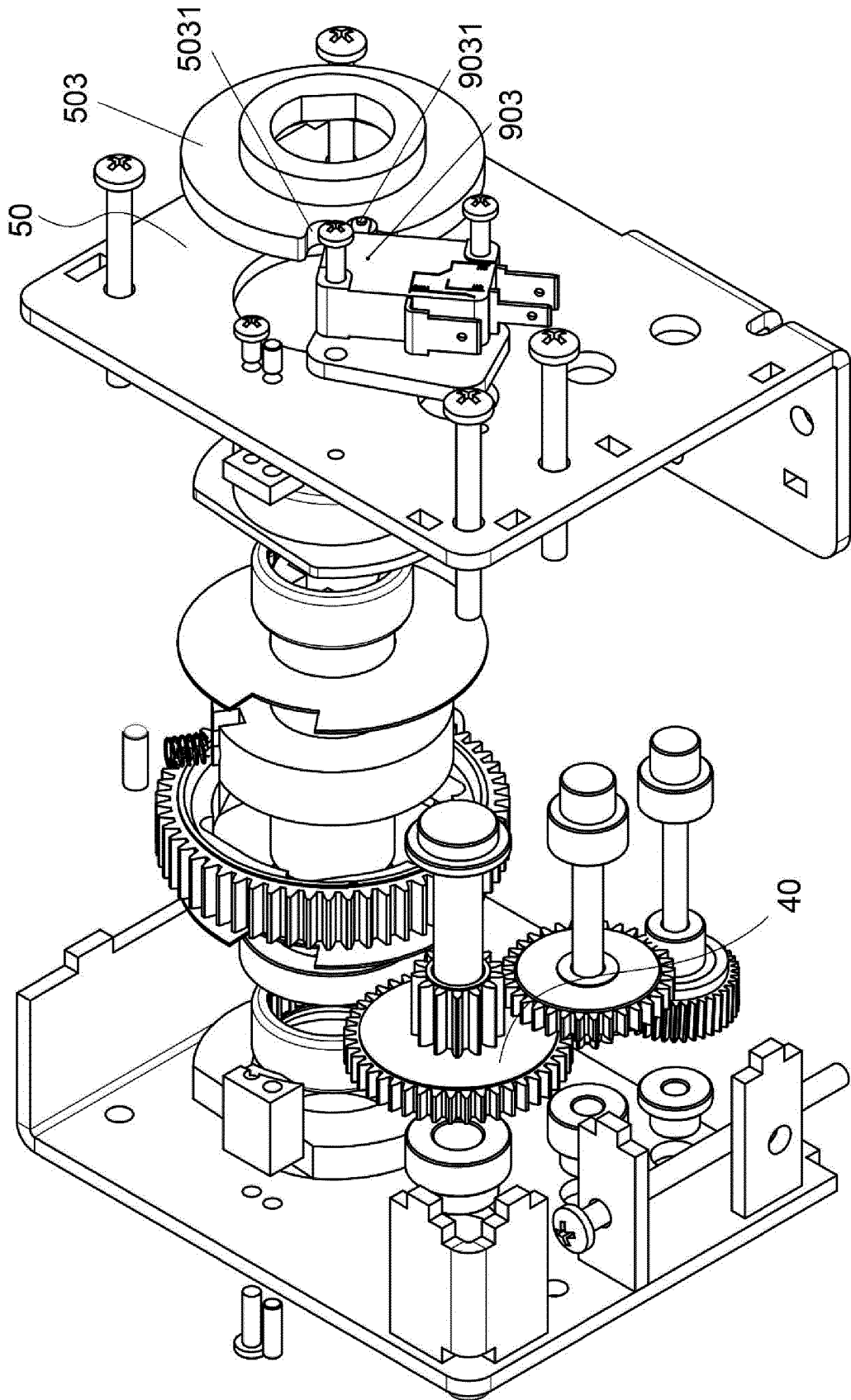

FIG.8

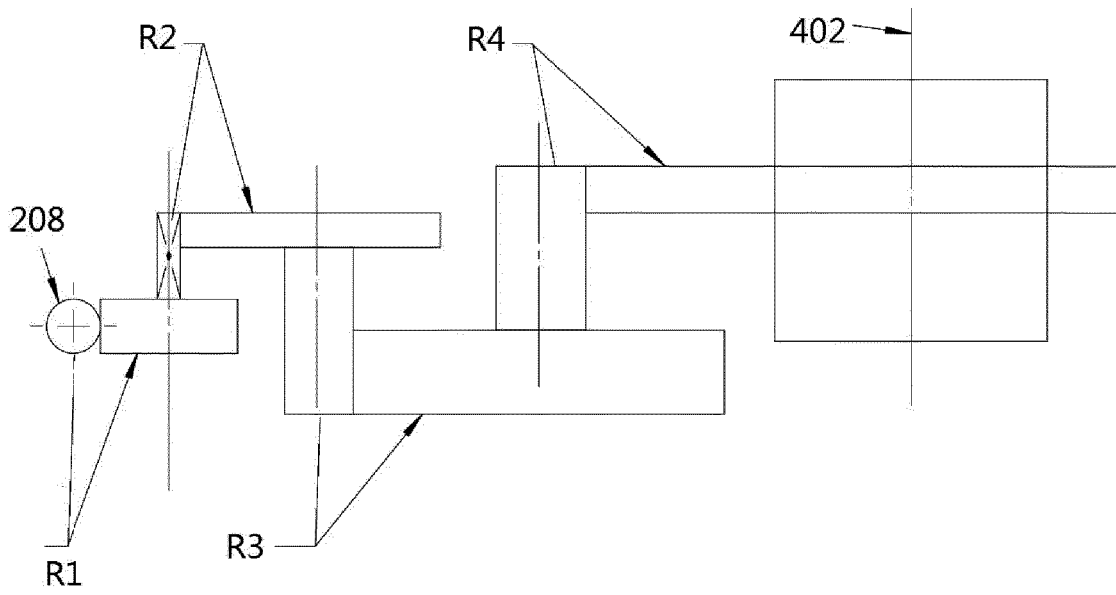

FIG. 9

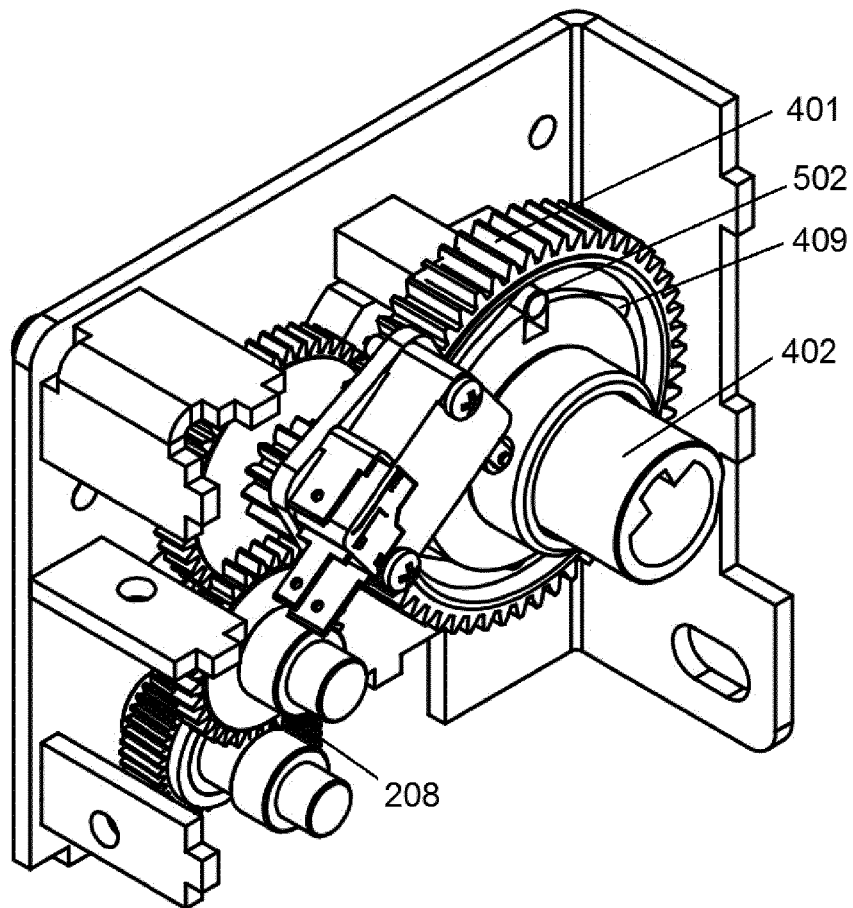

FIG. 10A

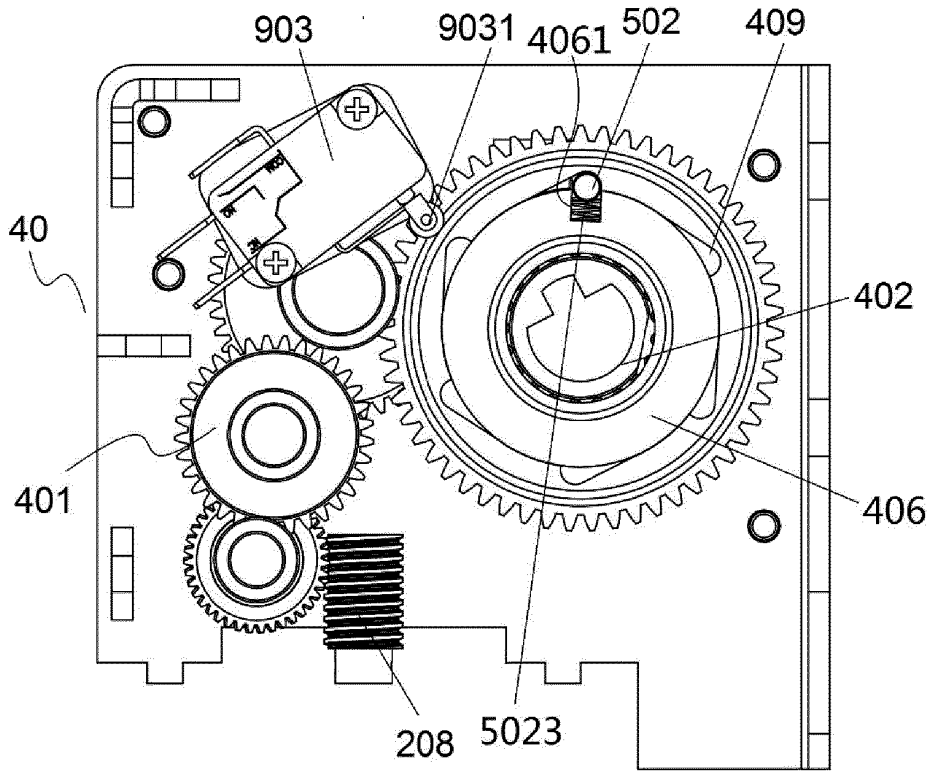

FIG.10B

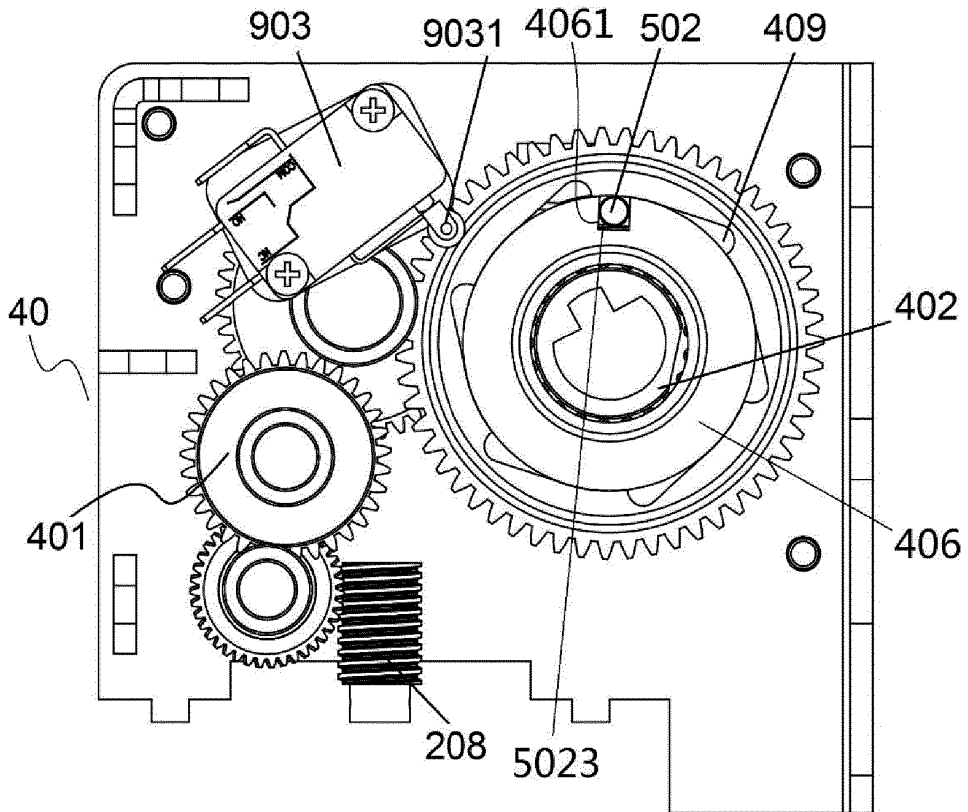

FIG.11

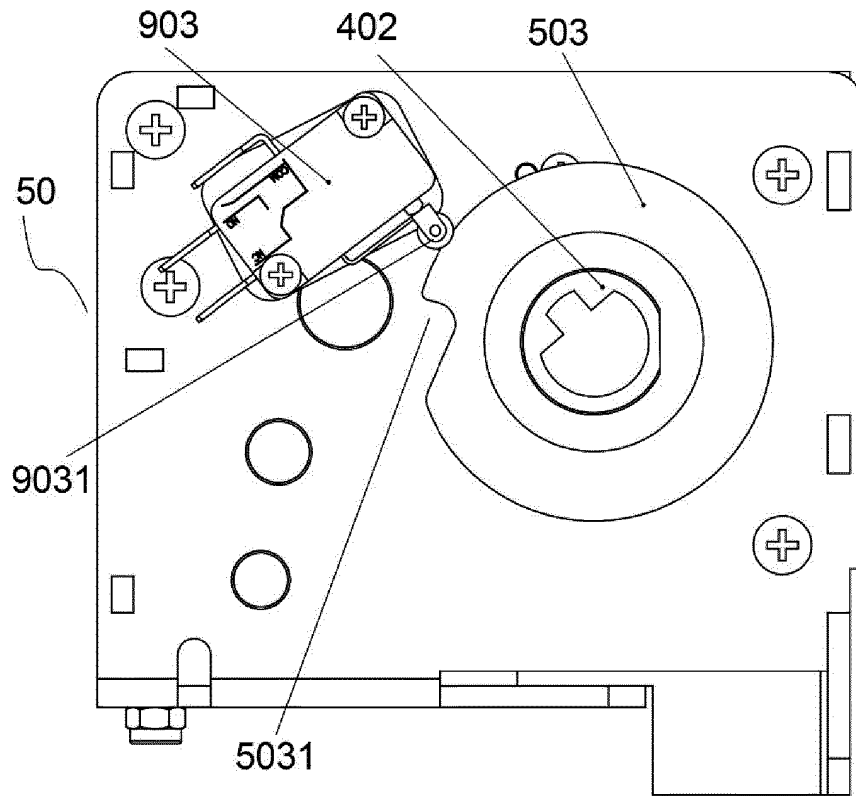

FIG.12A

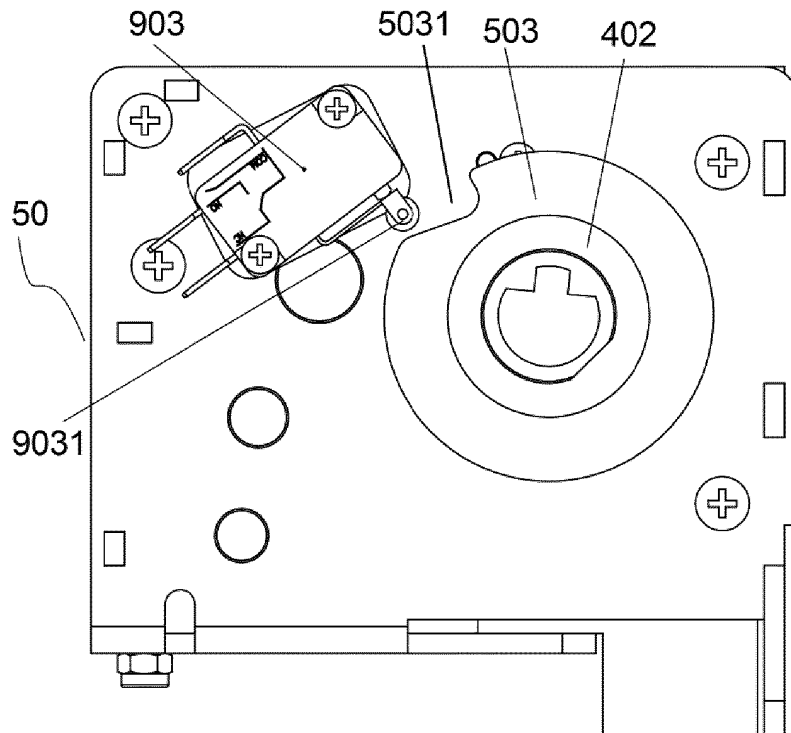

FIG.12B

REFERENCES CITED IN THE DESCRIPTION

This list of references cited by the applicant is for the reader's convenience only. It does not form part of the European patent document. Even though great care has been taken in compiling the references, errors or omissions cannot be excluded and the EPO disclaims all liability in this regard.

Patent documents cited in the description

- US 6107702 A [0009]
- CN 204906000 U [0010]
- JP 2011010475 A [0011]
- CN 101145454 A [0012]
- CN 102543500 A [0013]