

(19)



(11)

**EP 3 633 789 A1**

(12)

**EUROPEAN PATENT APPLICATION**

(43) Date of publication:  
**08.04.2020 Bulletin 2020/15**

(51) Int Cl.:  
**H01Q 1/48 (2006.01) H01Q 9/40 (2006.01)**

(21) Application number: **18275157.8**

(22) Date of filing: **05.10.2018**

(84) Designated Contracting States:  
**AL AT BE BG CH CY CZ DE DK EE ES FI FR GB GR HR HU IE IS IT LI LT LU LV MC MK MT NL NO PL PT RO RS SE SI SK SM TR**  
 Designated Extension States:  
**BA ME**  
 Designated Validation States:  
**KH MA MD TN**

(72) Inventor: **The designation of the inventor has not yet been filed**

(74) Representative: **BAE SYSTEMS plc**  
**Group IP Department**  
**Farnborough Aerospace Centre**  
**Farnborough**  
**Hampshire GU14 6YU (GB)**

(71) Applicant: **BAE SYSTEMS plc**  
**London SW1Y 5AD (GB)**

(54) **AN ANTENNA**

(57) Disclosed is an antenna comprising a substantially elliptical element arranged substantially perpendicular to, and spaced apart from, a substantially elliptical ground plane, wherein the substantially elliptical element

has a major axis which is substantially perpendicular to the ground plane, and a minor axis which is substantially parallel to the ground plane.

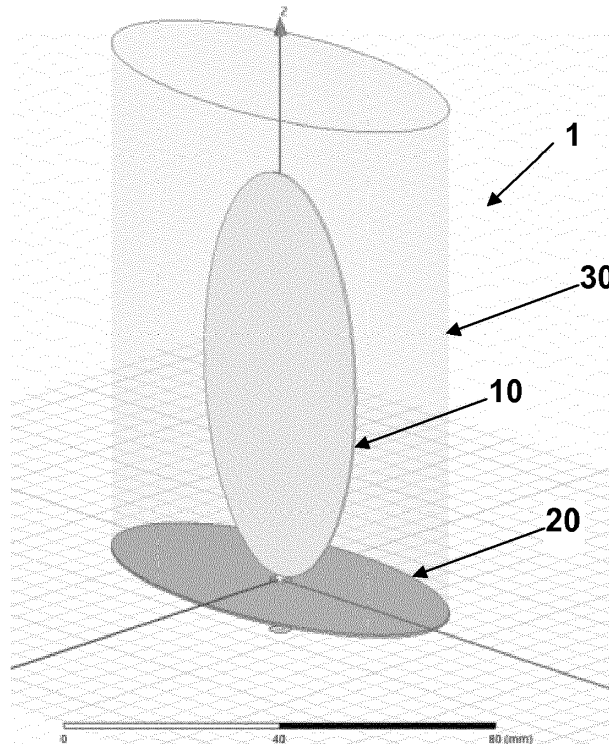

**Fig. 1**

**EP 3 633 789 A1**

## Description

**[0001]** The present invention relates to an antenna. It relates particularly to a wideband antenna having a particular arrangement of primary element and ground plane.

**[0002]** Antennas are essential in Radio Frequency Transmitter, Receivers and Transceivers. There are various forms of antennas, all of which have certain advantages or disadvantages. Much skill is required in the field of antenna design, not least since many of the competing system demands are difficult to reconcile.

**[0003]** In particular, for handheld or portable equipment, such as a mobile telephone or other such device, it is desirable to provide an antenna which provides suitable performance and which is, at the same time, unobtrusive.

**[0004]** Since the earliest mobile telephone devices were provided with an extendable whip antenna, users have demanded internal antennas which provide the same or better performance but which are not liable to inadvertent damage. This has led to the used of PIFA or similar antennas.

**[0005]** A further complication in antenna design is the increasing need to provide antennas which are operable at a suitable performance level across a wide bandwidth. Indeed, the requirement to operate across a large bandwidth has been prompted by developments such as Ultra wideband communications. In this context, Ultra wideband means operable over typically an octave (or more) frequency range.

**[0006]** A problem in the design of such ultra wideband antennas is reconciling different design constraints and still providing an antenna having acceptable performance across the desired range.

**[0007]** Embodiments of the present invention aim to address shortcomings in the prior art, whether mentioned herein or not.

**[0008]** According to the present invention there is provided an apparatus and method as set forth in the appended claims. Other features of the invention will be apparent from the dependent claims, and the description which follows.

**[0009]** According to the present invention there is provided an antenna comprising a substantially elliptical element arranged substantially perpendicular to, and spaced apart from, a substantially elliptical ground plane, wherein the substantially elliptical element has a major axis which is substantially perpendicular to the ground plane, and a minor axis which is substantially parallel to the ground plane.

**[0010]** Suitably, the minor axis of the substantially elliptical element is substantially aligned with a major axis of the ground plane.

**[0011]** Suitably, the major axis of the substantially elliptical element is substantially the same length as the major axis of the elliptical ground plane, and the minor axis of the substantially elliptical element is substantially

the same length as a minor axis of the ground plane.

**[0012]** Suitably, the space between the substantially elliptical element and the ground plane is selected so as to achieve a good impedance match between the substantially elliptical element and the ground plane.

**[0013]** Suitably, one or both of the substantially elliptical element and the ground plane is coated with a magneto-dielectric material.

**[0014]** Suitably, the antenna is encapsulated in a material such that the substantially elliptical element and the ground plane are physically shielded.

**[0015]** Suitably, the antenna is encapsulated in a foam material, such as ROHACELL HF.

**[0016]** For a better understanding of the invention, and to show how embodiments of the same may be carried into effect, reference will now be made, by way of example, to the accompanying diagrammatic drawings in which:

Figure 1 shows a perspective view of an antenna according to an embodiment of the present invention;

Figure 2 shows a plan view of an antenna according to an embodiment of the present invention;

Figure 3 shows a side view of an antenna according to an embodiment of the present invention; and

Figure 4 shows a VSWR plot of an antenna according to an embodiment of the present invention.

**[0017]** Figure 1 shows a perspective view of an antenna 1 according to an embodiment of the present invention. Figures 2 and 3 show plan and side views, respectively. As can be seen, the antenna 1 comprises two main parts: a substantially upright and substantially elliptical element 10, mounted in a spaced apart fashion from a substantially elliptical ground plane 20.

**[0018]** In the following description, the term elliptical is used to describe the two parts 10, 20 of the antenna 1. The term elliptical is qualified by the term substantially to mean strict compliance with the mathematical definition of an ellipse is not required. Instead, the term "Substantially elliptical" should be interpreted to mean a generally oval shape. At one extreme, a circle would not fall within the description and at another extreme, a rectangle with rounded corners would not. For brevity and ease of comprehension, whenever the term "elliptical" is used herein, it is not be interpreted as requiring absolute compliance with the mathematical definition and should be interpreted as "substantially elliptical".

**[0019]** In an embodiment, the element 10 is mounted atop a feed structure and is separated from the ground plane 20 by the feed structure. The element 10 is electrically isolated from the ground plane 20 by means of a suitable connector, such as a TNC or SMA connector. In this way, an antenna feed cable can be coupled to the

connector from a side of the ground plane opposite to the side above which element 10 is positioned. This separation also provides a degree of impedance matching. The absolute separation distance is determined on a trial and error basis as will be readily understood by the skilled person.

**[0020]** In a preferred embodiment, the size and shape of element 10 and ground plane 20 are identical. As can be seen in Figures 2 and 3, there are two dimensions defined for each of the parts 10, 20. Each part has a minor axis  $D_1$  and a major axis  $D_2$ . The major axis  $D_2 >$  minor axis  $D_1$ .

**[0021]** In another embodiment, the size and shape do not have to match exactly and it is acceptable for  $D_1$  and/or  $D_2$  to differ by  $\pm 20\%$ . It is found that variation of these dimensions in this range delivers an acceptable level of performance.

**[0022]** In a preferred embodiment, the ratio of  $D_2 : D_1$  is 2:1. In other embodiments, this can vary by  $\pm 20\%$ . It is found that variation of these dimensions in this range delivers an acceptable level of performance.

**[0023]** In the embodiment shown in Figures 1 to 3,  $D_2$  is 8cm and  $D_1$  is 4cm. An antenna having these dimensions is found to operate acceptably well over the frequency range 1 to 6GHz. This includes many popular frequency bands used in mobile telecommunication, as well as WiFi and other systems. Figure 4 shows a plot of the VSWR performance of an antenna 1 having these dimensions.

**[0024]** The use of an elliptic shape for a radiating part of an antenna is known, but the combination of an elliptic element 10 and a corresponding elliptical ground plane 20 is new and offers the benefits set out herein.

**[0025]** In use, the relatively wide elliptic surface acts as a mode filter and maintains a stable radiation field without overmodes and notches being introduced at high frequencies, giving a stable omnidirectional radiation pattern.

**[0026]** The ground plane 20 can be formed as a printed component on a circuit board and may be manufactured in a known way, using etching, deposition, milling or any suitable process. The element 10 can be formed as a unitary piece of metal or other conductor and can be formed by a cutting or milling operation. Typically, both ground plane 10 and element 20 are formed from copper. The thickness of each element is not typically critical and can vary from the standard thickness of a printed circuit board trace (e.g.  $17\mu\text{m}$ , as in 5oz copper) to a few millimetres, if formed from copper sheet.

**[0027]** The upright element 10 need not be strictly perpendicular to the ground plane 20, but should be substantially normal to it. In use, the element 10 may be mechanically vulnerable unless it can be somehow protected from environmental risks. These risks could include knocks as well as environmental risks from water and the like.

**[0028]** In an embodiment, the entire antenna, except for the connector (not shown) is encapsulated in a foam-

like material which protects the antenna and ensures that it remains mechanically sound. In figure 1, the foam 30 can be seen surrounding the element 10.

**[0029]** In a further embodiment, the foam-like material has suitable RF characteristics, such that it does not unduly interfere with the operation of the antenna 1. A suitable material is provided by ROHACELL® and is known as ROHACELL HF. This is robust, low density and moisture proof as well as having RF characteristics which do not impede the operation of the antenna. The foam surround 30 can be shaped as required for both practical and aesthetic purposes.

**[0030]** The Ultra wideband performance can be extended to lower frequencies. In the prior art, this would typically be achieved by a significant scaling up of the design or by means of dielectric loading. The former can result in an antenna which is significantly larger and often unsuitable, whereas the latter can lose some bandwidth.

**[0031]** In an embodiment of the present invention, however, it is possible to achieve the benefit of lower frequency operation without substantially altering the dimensions of the antenna by coating the element 10 and ground plane 20 is a magneto-dielectric material (MDM).

**[0032]** In tests conducted on the antenna thus far described, where  $D_2 = 8\text{cm}$  and  $D_1 = 4\text{cm}$ , a 6mm coating of both major antenna parts provides acceptable performance well down into VHF bands. The coating is applied to each side of element 10 and the upper side of ground plane 20. This has the benefit of further miniaturising embodiments of the present invention.

**[0033]** A suitable MDM according to an embodiment of the invention is known as Rogers Magtrex 555.

**[0034]** MDMs are able to achieve this performance by having unusually low loss magnetic permeability which combines with conventional dielectric permittivity. They enable antenna size reduction - or conversely lower frequency operation within a size constraint, without the drawbacks associated with traditional dielectric-only loading of poor match to free space impedance,  $Z_0$ . They achieve this by exploiting the following general relationships:

Overall Impedance:

$$Z = Z_0 \cdot \sqrt{\frac{U_r}{E_r}}$$

**Benefit:** Better matched to free space. Especially if  $U_r = E_r$  - a balanced material - which can thus improve bandwidth

**Miniaturisation factor**

$$\lambda = \frac{\lambda_0}{\sqrt{E_r \cdot U_r}}$$

**Benefit:** Useful miniaturisation factors can be achieved without the use of high Er ceramics etc

- Where Er = Relative Permittivity (or dielectric Constant) 10
- Ur = Relative Permeability
- And both also need to have low loss tangents to avoid loss of efficiency. 15

**[0035]** Whereas if Ur=1 (leaving Er as in a conventional dielectric) it results in less miniaturisation but poorer impedance matching and bandwidth (especially if high Er is used). 20

**[0036]** As magneto-dielectric materials are relatively dense, care should be taken to ensure weight constraints are met. In any event, excess thickness of MD may support unwanted rf overmodes or increase losses and should be avoided. 25

**[0037]** Embodiments of the present invention offer performance across a wide range of frequencies, with the antenna itself being compact and easy to produce.

**[0038]** Attention is directed to all papers and documents which are filed concurrently with or previous to this specification in connection with this application and which are open to public inspection with this specification, and the contents of all such papers and documents are incorporated herein by reference. 30

**[0039]** All of the features disclosed in this specification (including any accompanying claims, abstract and drawings), and/or all of the steps of any method or process so disclosed, may be combined in any combination, except combinations where at least some of such features and/or steps are mutually exclusive. 40

**[0040]** Each feature disclosed in this specification (including any accompanying claims, abstract and drawings) may be replaced by alternative features serving the same, equivalent or similar purpose, unless expressly stated otherwise. Thus, unless expressly stated otherwise, each feature disclosed is one example only of a generic series of equivalent or similar features. 45

**[0041]** The invention is not restricted to the details of the foregoing embodiment(s). The invention extends to any novel one, or any novel combination, of the features disclosed in this specification (including any accompanying claims, abstract and drawings), or to any novel one, or any novel combination, of the steps of any method or process so disclosed. 50

## Claims

1. An antenna comprising a substantially elliptical element arranged substantially perpendicular to, and spaced apart from, a substantially elliptical ground plane, wherein the substantially elliptical element has a major axis which is substantially perpendicular to the ground plane, and a minor axis which is substantially parallel to the ground plane. 5
2. The antenna of claim 1 wherein the minor axis of the substantially elliptical element is substantially aligned with a major axis of the ground plane.
3. The antenna of claim 2 wherein the major axis of the substantially elliptical element is substantially the same length as the major axis of the elliptical ground plane, and the minor axis of the substantially elliptical element is substantially the same length as a minor axis of the ground plane. 15
4. The antenna of any preceding claim wherein the space between the substantially elliptical element and the ground plane is selected so as to achieve a good impedance match between the substantially elliptical element and the ground plane. 25
5. The antenna of any preceding claim wherein one or both of the substantially elliptical element and the ground plane is coated with a magneto-dielectric material. 30
6. The antenna of any preceding claim wherein the antenna is encapsulated in a material such that the substantially elliptical element and the ground plane are physically shielded. 35
7. The antenna of claim 6 wherein the antenna is encapsulated in a foam material, such as ROHACELL HF. 40

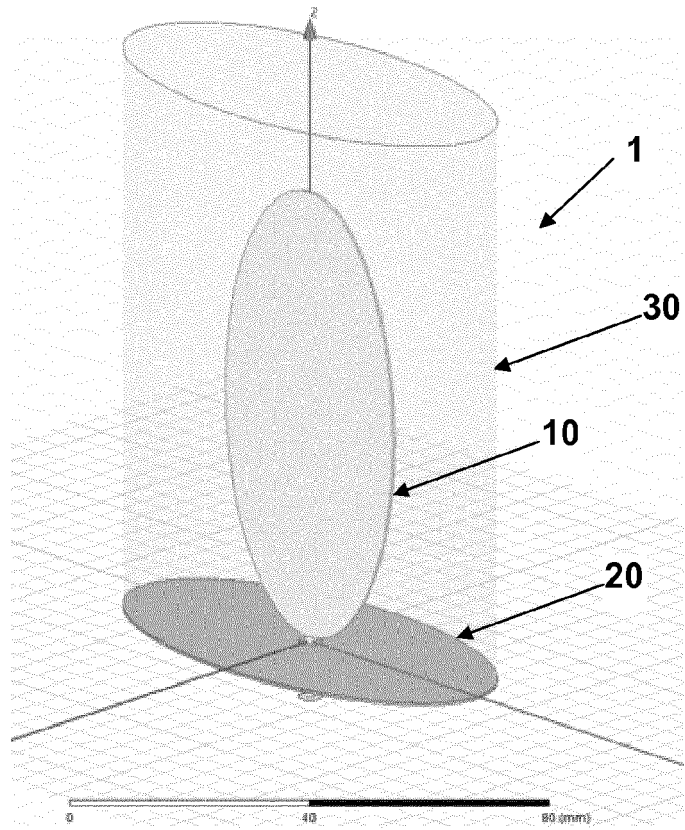

Fig. 1

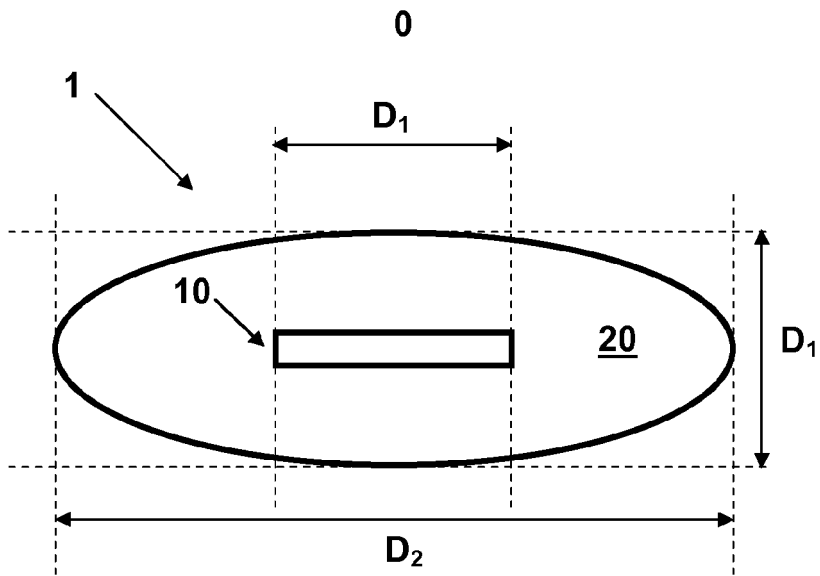

Fig. 2

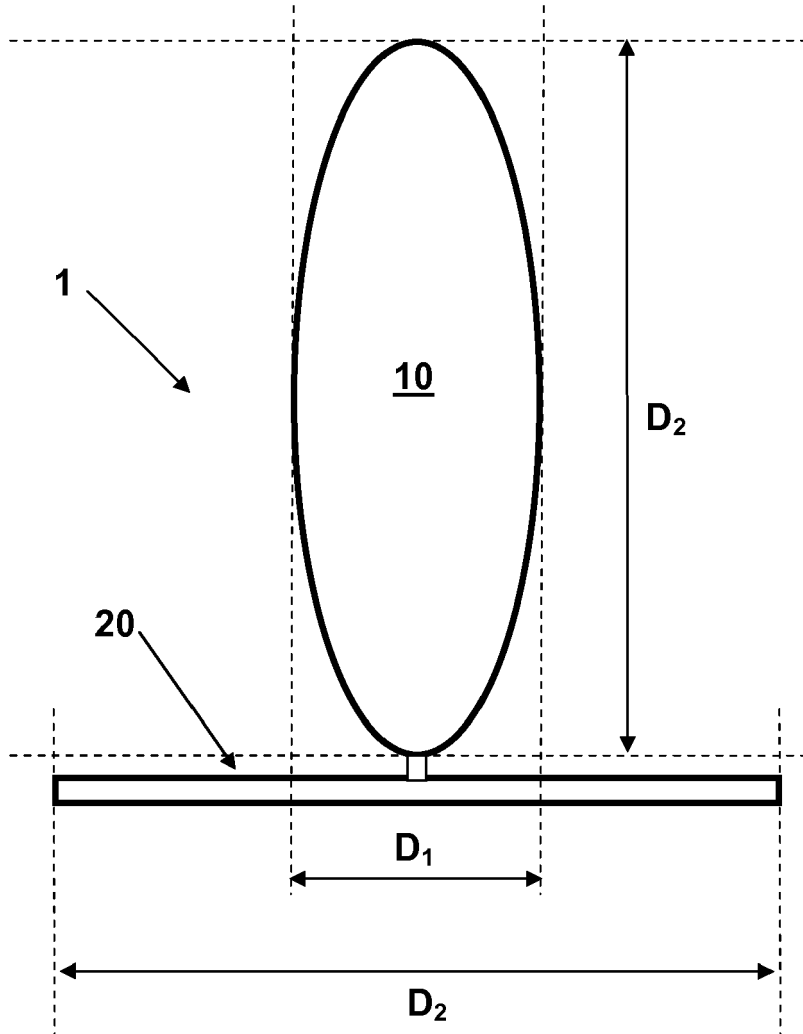

Fig. 3

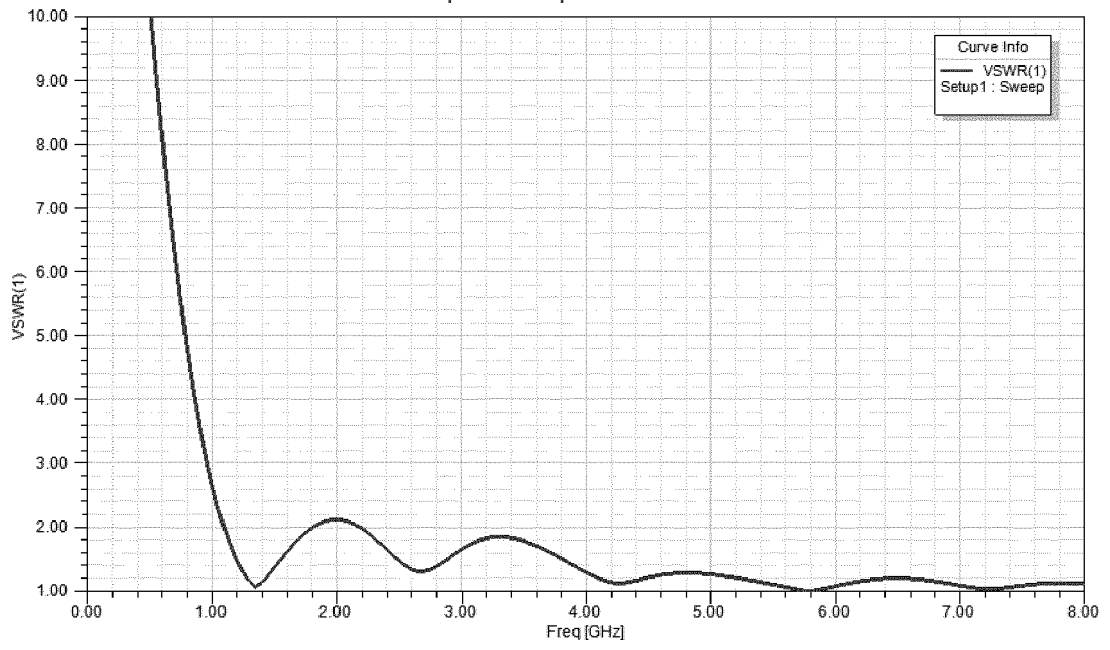

Fig. 4



EUROPEAN SEARCH REPORT

Application Number  
EP 18 27 5157

5

10

15

20

25

30

35

40

45

50

55

DOCUMENTS CONSIDERED TO BE RELEVANT			
Category	Citation of document with indication, where appropriate, of relevant passages	Relevant to claim	CLASSIFICATION OF THE APPLICATION (IPC)
X	US 7 183 978 B1 (AZAR TONY [US]) 27 February 2007 (2007-02-27)	1-4,6,7	INV. H01Q1/48 H01Q9/40
Y	* figures 1-4 * * column 2, line 57 - line 63 * * column 3, line 20 - line 35 * * column 4, line 23 - line 32 * * column 4, line 37 - line 38 * * column 4, line 48 - line 50 * * column 4, line 64 - line 67 * * column 5, line 10 - line 16 * -----	5	
X	WO 2004/066441 A1 (YOKOHAMA TLO COMPANY LTD [JP]; ARAI HIROYUKI [JP]; KUGA NOBUHIRO [JP]) 5 August 2004 (2004-08-05) * figure 1 * * paragraph [0026] - paragraph [0029] * -----	1,2	TECHNICAL FIELDS SEARCHED (IPC)  H01Q
Y	WO 2012/027006 A2 (WISCONSIN ALUMNI RES FOUND [US] ET AL.) 1 March 2012 (2012-03-01) * paragraph [0005] * * paragraph [0027] * * paragraph [0054] * * claim 23 * -----	5	
The present search report has been drawn up for all claims			
Place of search <b>The Hague</b>		Date of completion of the search <b>4 April 2019</b>	Examiner <b>Gehrmann, Elke</b>
CATEGORY OF CITED DOCUMENTS X : particularly relevant if taken alone Y : particularly relevant if combined with another document of the same category A : technological background O : non-written disclosure P : intermediate document T : theory or principle underlying the invention E : earlier patent document, but published on, or after the filing date D : document cited in the application L : document cited for other reasons & : member of the same patent family, corresponding document			

EPO FORM 1503 03.82 (P04C01)

**ANNEX TO THE EUROPEAN SEARCH REPORT  
ON EUROPEAN PATENT APPLICATION NO.**

EP 18 27 5157

5 This annex lists the patent family members relating to the patent documents cited in the above-mentioned European search report.  
The members are as contained in the European Patent Office EDP file on  
The European Patent Office is in no way liable for these particulars which are merely given for the purpose of information.

04-04-2019

Patent document cited in search report	Publication date	Patent family member(s)	Publication date
US 7183978 B1	27-02-2007	NONE	
-----	-----	-----	-----
WO 2004066441 A1	05-08-2004	AU 2003280780 A1	13-08-2004
		WO 2004066441 A1	05-08-2004
-----	-----	-----	-----
WO 2012027006 A2	01-03-2012	US 2012169554 A1	05-07-2012
		WO 2012027006 A2	01-03-2012
-----	-----	-----	-----

EPO FORM P0459

For more details about this annex : see Official Journal of the European Patent Office, No. 12/82