



(11) **EP 3 640 420 B1**

(12) **EUROPEAN PATENT SPECIFICATION**

(45) Date of publication and mention of the grant of the patent:
08.11.2023 Bulletin 2023/45

(21) Application number: **18200755.9**

(22) Date of filing: **16.10.2018**

(51) International Patent Classification (IPC):
E05B 81/76^(2014.01) E05B 85/10^(2014.01)

(52) Cooperative Patent Classification (CPC):
E05B 81/77; E05B 81/76; E05B 85/103; E05B 85/107

(54) **A HANDLE ASSEMBLY AND A METHOD FOR DETECTING THE POSITION OF A DOOR HANDLE**
GRIFFANORDNUNG UND VERFAHREN ZUR DETEKTION DER POSITION EINES TÜRGRIFFS
ENSEMBLE POIGNÉE ET PROCÉDÉ PERMETTANT DE DÉTECTER LA POSITION D'UNE POIGNÉE DE PORTE

(84) Designated Contracting States:
AL AT BE BG CH CY CZ DE DK EE ES FI FR GB GR HR HU IE IS IT LI LT LU LV MC MK MT NL NO PL PT RO RS SE SI SK SM TR

(43) Date of publication of application:
22.04.2020 Bulletin 2020/17

(73) Proprietor: **Minebea AccessSolutions Deutschland GmbH**
85253 Erdweg (DE)

(72) Inventor: **Krauss, Dietmar**
85253 Erdweg (DE)

(74) Representative: **Prinz & Partner mbB Patent- und Rechtsanwälte**
Rundfunkplatz 2
80335 München (DE)

(56) References cited:
WO-A1-2017/198921 DE-A1-102016 007 112
US-A1- 2016 222 703 US-A1- 2017 167 169

EP 3 640 420 B1

Note: Within nine months of the publication of the mention of the grant of the European patent in the European Patent Bulletin, any person may give notice to the European Patent Office of opposition to that patent, in accordance with the Implementing Regulations. Notice of opposition shall not be deemed to have been filed until the opposition fee has been paid. (Art. 99(1) European Patent Convention).

Description

[0001] The invention relates to a handle assembly for a vehicle door and to a method for detecting the position of a door handle.

[0002] Door handles for vehicles typically protrude from the vehicle door and may interfere with the aerodynamics and/or the design of the vehicle. For that purpose, extendable door handles have been developed which can be moved from a retracted position in which they are flush with the outer contour of the vehicle, to an extended position of use in which a user can easily grab the handle.

[0003] For instance, US 2016/0 222 703 A1 discloses a handle for a vehicle door. The handle comprises a first sensor at a distal end of the handle for detecting the operation of the handle, a second sensor for detecting the proximity of a user, and an additional sensor, e.g. a switch, for detecting a projected position of the handle.

[0004] For proper operation of these handles, it however is essential that a control positively knows in which position the handle currently is. This entails that use of additional micro switches or hall sensors for detecting the position of the handle. These sensors are expensive and require precious space in the handle or in the door structure in the vicinity of the handle.

[0005] The object of the invention is to provide reliable information on the position of the door handle in a manner which is cost effective and space saving.

[0006] For this purpose, the invention provides a handle assembly for a vehicle door according to claim 1 and a method for detecting the position of a door handle according to claim 5.

[0007] The invention is based on the basic idea to use the capacitive sensors needed anyhow for the detection of a hand approach or a hand touch of the handle, for also detecting the position of the handle. Thereby, additional micro switches and/or hall sensors are not necessary, and the handle assembly can be built more cost effective and space saving.

[0008] By means of the detection, it can be determined in particular if the door handle is in the retracted or the extended position.

[0009] If desired, intermediate position can however also be detected.

[0010] Advantageously, the capacitive sensor contains no mechanical moving parts and is not subject to wear as it is for example for micro switches. Additionally, a capacitive sensor is less complex than a unit with hall sensor with related magnet and mechanical parts. Therefore, the lifetime of the handle unit is improved.

[0011] According to an embodiment of the invention, provision is made that the capacitive sensor may comprise a copper area on a printed circuit board assembly. Capacitive sensors comprising a copper area on a printed circuit board assembly are very cheap in the production enabling the production of a cost effective handle assembly.

[0012] It may be beneficial to provide a second capac-

itive sensor to the handle assembly with special shape and position for instance near the edge of the circuit board, which allows better precision for the special purpose of position detection. Consequently, the positions of the handle may be detected more reliably.

[0013] Alternatively, the second sensor could offer additional functionality to the handle assembly if the second sensor is not a capacitive sensor. A finger print sensor could handle, for example, the verification procedure to enter the car and possibly replace the vehicle keys.

[0014] Advantageously, the signal may be evaluated to determine intermediate positions as well. Therefore, additional sensors for detection of intermediate positions for instance, additional micro switches or hall sensors become redundant enabling a cost effective handle assembly.

[0015] According to an embodiment of the invention, provision is made that a signal from a second capacitive sensor may be taken into account in the detection of the different positions. By using all available signals, the resolution of the position detection can be increased and the signals from the different sensors can be mutually verified.

[0016] Advantageously, the first and second capacitive sensors may be used for opening and closing a door lock. As a consequence, additional parts for opening and closing the door lock become redundant.

[0017] Further features and advantages of the invention will be apparent from the following description of two embodiments of the invention with the aid of the enclosed drawings, in which:

- Figure 1 shows a schematic drawing of a car with a handle assembly according to the innovation,
- Figure 2 illustrates a perspective view of the vehicle door of Figure 1 wherein the handle of the handle assembly is in a retracted position,
- Figure 3 shows in perspective view the vehicle door of Figure 1 with the handle of the handle assembly being in an extended position,
- Figure 4 illustrates a perspective view of a second embodiment of the invention.

[0018] It should be understood that figures 1 to 4 are schematic in nature and do not necessarily illustrate the particular appearance or configuration that may be used in the commercial implementation of the invention.

[0019] Figure 1 shows a car 10 with multiple vehicle doors 12 each of which comprises a handle assembly 14.

[0020] A schematic example of the handle assembly 14 is shown in Figure 2. The handle assembly 14 comprises a handle support 15, a handle 16, an evaluation circuit 17, and a capacitive sensor 18 which is located on an outer surface 20 of the handle 16.

[0021] Handle support 15 carries handle 16 and all

components (motor, guide for the handle, gear, etc.) necessary for moving handle 16 from the retracted position to the extended position, and vice versa. Further, handle support 15 closes the opening the door structure so that dirt, water, etc. cannot enter into the door. In Figure 2, the handle 16 is shown in a retracted position in which the outer surface 20 of the handle 16 is substantially flush with the outer surface 22 of the vehicle door. As a consequence, capacitive sensor 18 has a small distance from the sheet metal from which defines the outer surface 22 of the vehicle door.

[0022] From the retracted position, handle 16 can be moved into an extended position as shown in figure 3. In the extended position, handle 16 protrudes outwardly from door 12 and from handle support 15 so that it a user can easily grab the handle and open vehicle door 12.

[0023] In the extended position, capacitive sensor 12 has a distance from the outer surface 22 of the vehicle door 12 which is larger than in the retracted position of handle 16.

[0024] In Figure 3, two rods 24 are visible which symbolize the guide for handle 16 and which allow displacing handle 16 between the retracted position and the extended position. The rods 24 extend from handle 16 through apertures 25 in handle support 15 to a drive mechanism which is adapted for displacing handle 16 between the extended and the retracted positions, and vice versa. Details of the drive are not necessary here as the nature of the drive is not necessary for understanding the invention.

[0025] Other types of mounting mechanisms for door handle 16 are feasible as well, e.g. a pivotable mounting mechanism.

[0026] Handle support 15 comprises a cavity 23 which has a contour corresponding to the contour of handle 16. Accordingly, handle 16 snugly fits into cavity 23 in the retracted position

[0027] Displacement of handle 16 from the extended position to the retracted position can be triggered by a signal which indicates that door 12 was closed, by a lapse of a predefined time period since the last actuation, a signal from a keyless go system, etc.

[0028] Displacement of handle 16 from the retracted position to the extended position can be triggered in particular by a signal from capacitive sensor 18 which indicates that a hand is in the vicinity of handle 16 or that handle 16 has been touched. A signal from a keyless go system can be taken into account as well.

[0029] Capacitive sensor 18 here comprises two electrodes realized by copper areas on a printed circuit board assembly. Other types of capacitive sensors can be used as well.

[0030] In a manner known as such, evaluation circuit 17 is able to determine the capacity of capacitive sensor 18 which changes when there is a change of the dielectric constant in the vicinity of capacitive sensor 18. This can be used for detecting whether or not handle 16 was touched by a user or if the hand of a user is approaching

handle 16.

[0031] In addition to detection of the change of the dielectric constant caused by body parts of a user approaching capacitive sensor 18, evaluation circuit 17 is able to detect the change of the dielectric constant in the vicinity of capacitive sensor 18 caused by a displacement of handle 16 between the retracted position and the extended position.

[0032] In the retracted position, capacitive sensor 18 is very close to the sheet metal defining the outer structure of vehicle door 12. In the extended position of handle 16, capacitive sensor 12 is at a larger distance from the sheet metal. Thus, there is a notable difference in the capacity of capacitive sensor 18, and evaluation circuit 17 can detect whether door handle 18 is in the retracted position or in and extended position.

[0033] The evaluation circuit 17 is also adapted to detect intermediate positions of door handle 12 between the extracted position and the extended position.

[0034] It is generally possible to integrate more than one capacitive sensor 18 into the outer side of handle 16.

[0035] It is also possible that the evaluation circuit 17 evaluates the capacity between a conductive surface arranged in or at door handle 16, and a conductive surface arranged stationary at vehicle door 12. This could be a dedicated surface associated with handle support 15, or even the sheet metal of door 12.

[0036] In figure 4, a second embodiment of the invention is shown which essentially corresponds to the first embodiment. Therefore, only the differences over the first embodiment are mentioned in the following. Identical and functionally identical components are provided with the same reference numerals.

[0037] The difference over the first embodiment is that in the second embodiment, there is an additional sensor 28 on the inner or outer side of handle 16.

[0038] Advantageously, sensor 28 is an additional capacitive sensor 18 such that the position of the handle can be detected with a higher accuracy.

[0039] In case that the handle assembly 14 comprises at least two capacitive sensors 18, one capacitive sensor 18 could trigger the locking and the other one could trigger the unlocking of the vehicle door 12 in case the evaluation circuit 17 detects the vicinity of a hand and/or a touching of one of the capacitive sensors 18.

[0040] Additionally, the second capacitive sensor 18 could be placed at a position in the handle 16 such that it is only sensitive to the movement of the handle 16 and not to the vicinity of a hand.

[0041] The different features of the two embodiments can be combined with each other in any way. In particular, the features listed as differences to the second embodiment are independent and can also exist in different ways in the first embodiment.

Claims

1. A handle assembly (14) for a vehicle door (12), comprising a handle (16) which is movable between a retracted position and an extended position, and evaluation circuit (17) and at least one capacitive sensor (18) arranged at the handle (16), the evaluation circuit (17) being adapted for detecting the presence of a hand in the vicinity of the sensor and in addition being adapted for determining the position of the handle, **characterized in that**, the evaluation circuit (17) is adapted to use the capacitive sensor (18) for the detection of a hand approach or a hand touch of the handle (16) and also for detecting the position of the handle (16). 5
2. The handle assembly (14) of claim 1 wherein the capacitive sensor (18) is completely covered by the material of the handle (16). 10
3. The handle assembly (14) of any one of the preceding claims wherein the capacitive sensor (18) comprises a copper area on a printed circuit board assembly. 15
4. The handle assembly (14) of any one of the preceding claims wherein a second sensor (28) is provided. 20
5. A method for detecting the position of a door handle (16) of a handle assembly (14) which is movable between a retracted position and an extended position, in particular of a door handle (16) which is part of the handle assembly (14) as defined in any one of the preceding claims, the handle assembly (14) comprising an evaluation circuit (17) and at least one capacitive sensor (18), the evaluation circuit (17) being adapted for detecting the presence of a hand in the vicinity of the sensor (18) and in addition being adapted for determining the position of the handle (16), the method comprising: 25
 - a) receiving by the evaluation circuit (17) a signal from a capacitive sensor (18) arranged in the handle (16), **characterized by**
 - b) evaluating by the evaluation circuit (17) the signal from the capacitive sensor (18) in order to detect a user hand in the vicinity of the handle (16), and
 - c) if no user hand is detected, evaluating by the evaluation circuit (17) the signal from the capacitive sensor (18) in order to determine the position of the door handle (16). 30
6. The method of claim 5 wherein the signal is evaluated to determine if the door handle is in an extended or in a retracted position. 35
7. The method of claim 5 or claim 6 wherein the signal 40

is evaluated to determine intermediate positions.

8. The method of any of claims 5 to 7 wherein a signal from a second capacitive sensor (18) is taken into account. 45
9. The method of claim 8 in the first and second capacitive sensors (18) are also used for opening and closing a door lock. 50

Patentansprüche

1. Griffbaugruppe (14) für eine Fahrzeugtür (12), mit einem Griff (16), der zwischen einer eingezogenen Stellung und einer ausgefahrenen Stellung bewegbar ist, einer Auswerteschaltung (17) und wenigstens einem am Griff (16) angeordneten kapazitiven Sensor (18), wobei die Auswerteschaltung (17) dazu eingerichtet ist, die Anwesenheit einer Hand in der Nähe des Sensors zu erkennen, und darüber hinaus dazu eingerichtet ist, die Stellung des Griffes zu bestimmen, **dadurch gekennzeichnet, dass** die Auswerteschaltung (17) dazu eingerichtet ist, den kapazitiven Sensor (18) zur Erkennung der Annäherung einer Hand oder einer Berührung des Griffes (16) mit der Hand sowie zur Erkennung der Stellung des Griffes (16) zu verwenden. 55
2. Griffbaugruppe (14) nach Anspruch 1, bei der der kapazitive Sensor (18) vollständig vom Material des Griffes (16) bedeckt ist. 60
3. Griffbaugruppe (14) nach einem der vorhergehenden Ansprüche, bei der der kapazitive Sensor (18) einen Kupferbereich auf einer Leiterplattenbaugruppe umfasst. 65
4. Griffbaugruppe (14) nach einem der vorhergehenden Ansprüche, bei der ein zweiter Sensor (28) vorgesehen ist. 70
5. Verfahren zur Erkennung der Stellung eines Türgriffs (16) einer Griffbaugruppe (14), der zwischen einer eingezogenen Stellung und einer ausgefahrenen Stellung bewegbar ist, insbesondere eines Türgriffs (16), der Teil der in einem der vorhergehenden Ansprüche definierten Griffbaugruppe (14) ist, wobei die Griffbaugruppe (14) eine Auswerteschaltung (17) und wenigstens einen kapazitiven Sensor (18) umfasst, wobei die Auswerteschaltung (17) dazu eingerichtet ist, die Anwesenheit einer Hand in der Nähe des Sensors (18) zu erkennen, und darüber hinaus dazu eingerichtet ist, die Stellung des Griffes (16) zu bestimmen, wobei das Verfahren Folgendes umfasst: 75
 - a) Empfangen eines Signals von einem im Griff

- (16) angeordneten kapazitiven Sensor (18) durch die Auswerteschaltung (17), **gekennzeichnet durch**
- b) Auswerten des Signals von dem kapazitiven Sensor (18) durch die Auswerteschaltung (17), um eine Hand eines Benutzers in der Nähe des Griffes (16) zu erkennen, und
- c) wenn keine Hand des Benutzers erkannt wird, Auswerten des Signals von dem kapazitiven Sensor (18) durch die Auswerteschaltung (17), um die Stellung des Türgriffs (16) zu bestimmen.
6. Verfahren nach Anspruch 5, bei dem das Signal ausgewertet wird, um festzustellen, ob sich der Türgriff in einer ausgefahrenen oder in einer eingezogenen Stellung befindet.
7. Verfahren nach Anspruch 5 oder Anspruch 6, bei dem das Signal ausgewertet wird, um Zwischenstellungen festzustellen.
8. Verfahren nach einem der Ansprüche 5 bis 7, bei dem ein Signal von einem zweiten kapazitiven Sensor (18) berücksichtigt wird.
9. Verfahren nach Anspruch 8, bei dem der erste und der zweite kapazitive Sensor (18) auch zum Öffnen und Schließen eines Türschlosses verwendet werden.

Revendications

1. Ensemble de poignée (14) pour une portière de véhicule (12), comprenant une poignée (16) qui est mobile entre une position rétractée et une position sortie, et un circuit d'évaluation (17) et au moins un capteur capacitif (18) agencé sur la poignée (16), le circuit d'évaluation (17) étant apte à détecter la présence d'une main au voisinage du capteur et en outre apte à déterminer la position de la poignée, **caractérisé en ce que** le circuit d'évaluation (17) est apte à utiliser le capteur capacitif (18) pour la détection de l'approche d'une main ou le contact d'une main avec la poignée (16) et également pour la détection de la position de la poignée (16).
2. Ensemble de poignée (14) selon la revendication 1, le capteur capacitif (18) étant entièrement recouvert du matériau de la poignée (16).
3. Ensemble de poignée (14) selon l'une des revendications précédentes, le capteur capacitif (18) comprenant une zone de cuivre sur un ensemble de carte de circuits imprimés.
4. Ensemble de poignée (14) selon l'une des revendications

précédentes, un deuxième capteur (28) étant prévu.

5. Procédé de détection de la position d'une poignée de portière (16) d'un ensemble de poignée (14) qui est mobile entre une position rétractée et une position sortie, en particulier une poignée de portière (16) qui fait partie de l'ensemble de poignée (14) tel que défini selon l'une des revendications précédentes, l'ensemble de poignée (14) comprenant un circuit d'évaluation (17) et au moins un capteur capacitif (18), le circuit d'évaluation (17) étant apte à détecter la présence d'une main au voisinage du capteur (18) et en outre apte à déterminer la position de la poignée (16), le procédé comprenant :
- a) la réception, par le circuit d'évaluation (17), d'un signal provenant d'un capteur capacitif (18) agencé dans la poignée (16), **caractérisé par**
- b) l'évaluation, au moyen du circuit d'évaluation (17), du signal provenant du capteur capacitif (18) pour détecter la main d'un utilisateur au voisinage de la poignée (16), et
- c) si aucune main d'utilisateur n'est détectée, l'évaluation, au moyen du circuit d'évaluation (17), du signal provenant du capteur capacitif (18) pour déterminer la position de la poignée de portière (16).
6. Procédé selon la revendication 5, le signal étant évalué pour déterminer si la poignée de portière se trouve dans une position sortie ou une position rétractée.
7. Procédé selon la revendication 5 ou la revendication 6, le signal étant évalué pour déterminer des positions intermédiaires.
8. Procédé selon l'une des revendications 5 à 7, un signal provenant d'un deuxième capteur capacitif (18) étant pris en compte.
9. Procédé selon la revendication 8, le premier et le deuxième capteur capacitif (18) étant également utilisés pour ouvrir et fermer une serrure de portière.

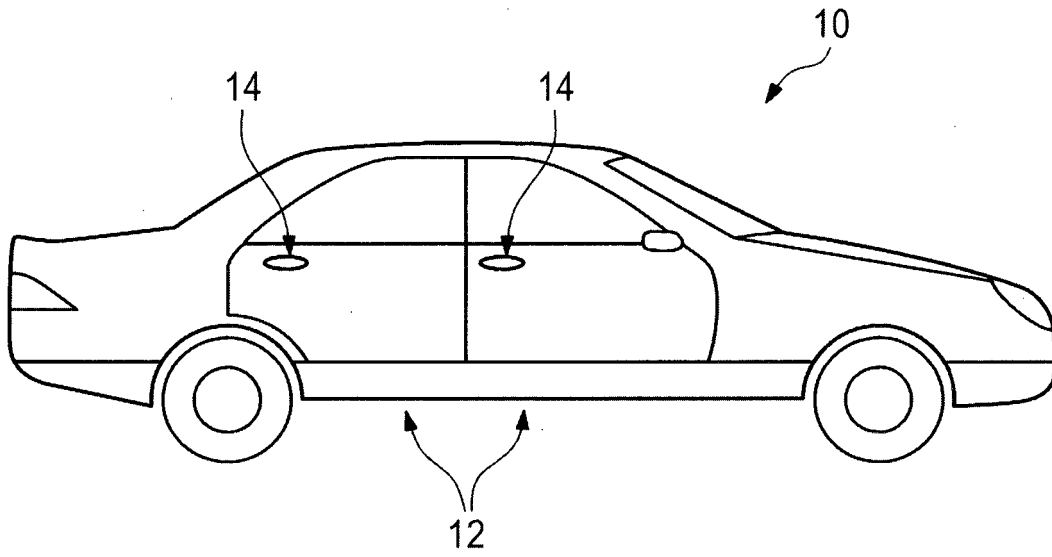

Fig. 1

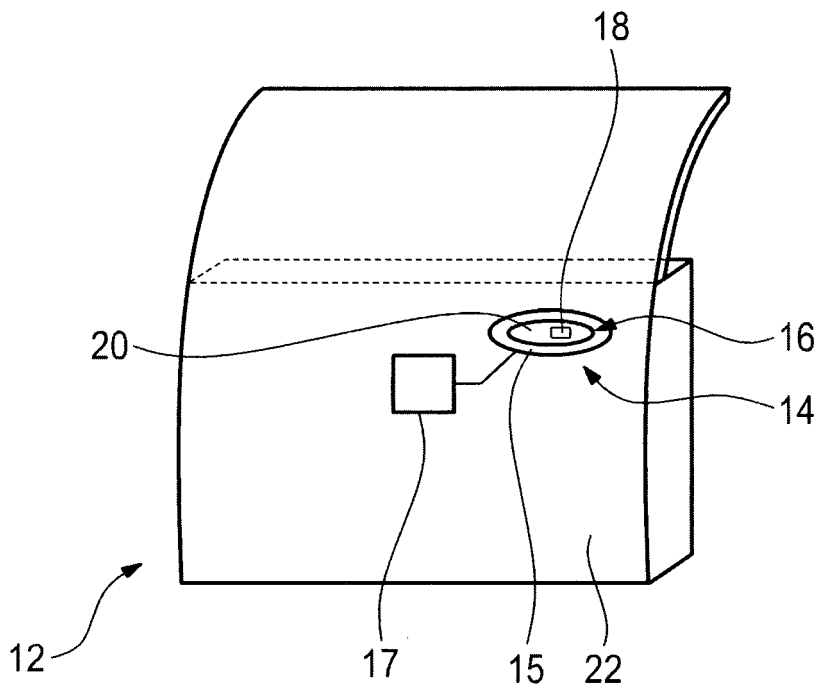

Fig. 2

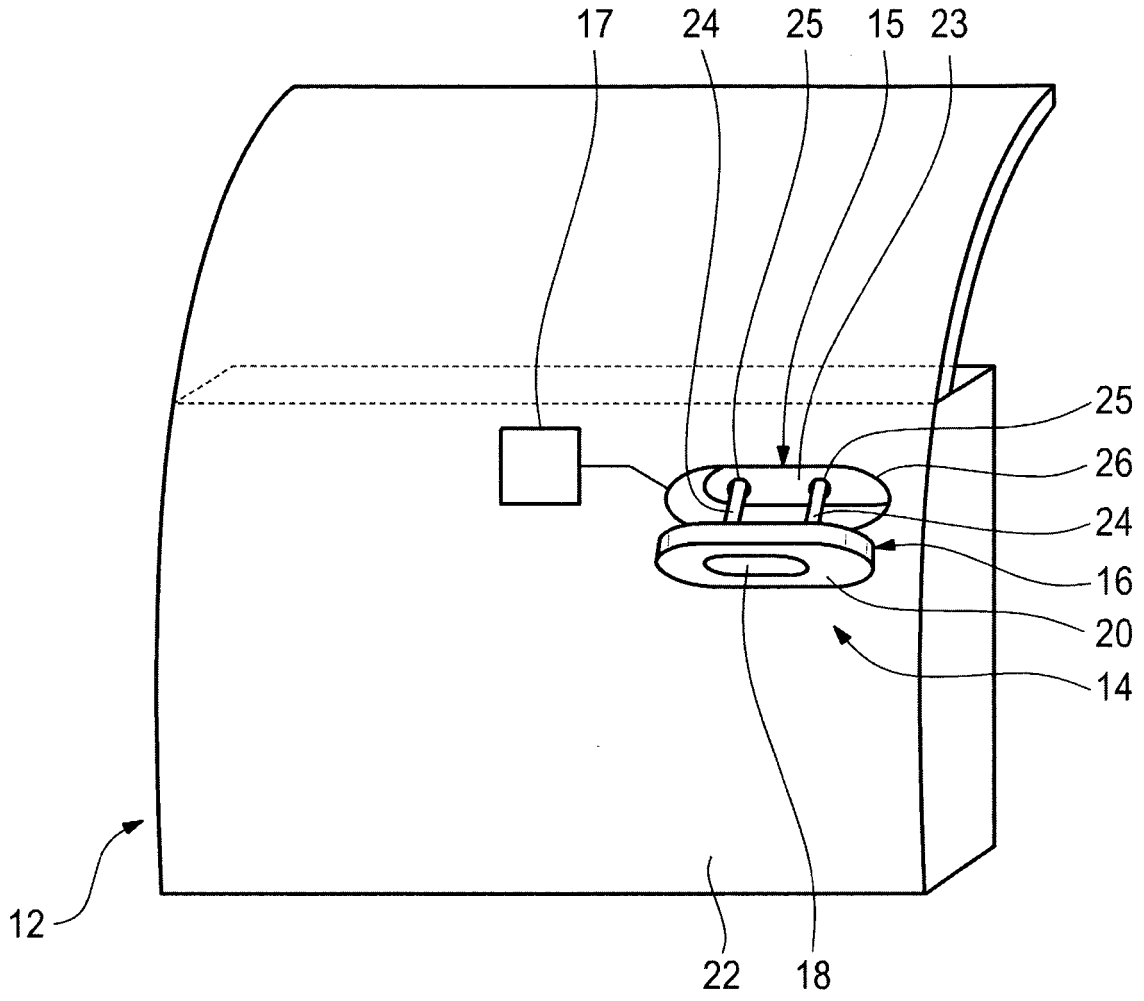

Fig. 3

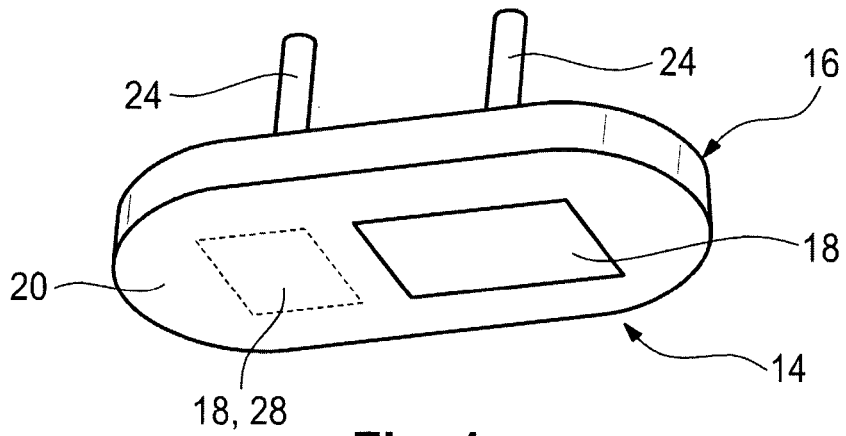

Fig. 4

REFERENCES CITED IN THE DESCRIPTION

This list of references cited by the applicant is for the reader's convenience only. It does not form part of the European patent document. Even though great care has been taken in compiling the references, errors or omissions cannot be excluded and the EPO disclaims all liability in this regard.

Patent documents cited in the description

- US 20160222703 A1 [0003]