

(19)



(11)

EP 3 643 623 B1

(12)

EUROPEAN PATENT SPECIFICATION

(45) Date of publication and mention of the grant of the patent:
20.07.2022 Bulletin 2022/29

(51) International Patent Classification (IPC):
B65B 1/04 (2006.01) **B65B 1/06** (2006.01)
B65B 3/04 (2006.01) **B65B 3/32** (2006.01)
B65B 39/12 (2006.01)

(21) Application number: **19205117.5**

(52) Cooperative Patent Classification (CPC):
B65B 1/04; B65B 1/06; B65B 3/04; B65B 3/32; B65B 39/12

(22) Date of filing: **24.10.2019**

(54) IMPROVEMENTS TO APPARATUS AND METHOD FOR FILLING CONTAINERS

VERBESSERUNGEN AN VORRICHTUNG UND VERFAHREN ZUR BEFÜLLUNG VON BEHÄLTERN
AMÉLIORATIONS APPORTÉES À UN APPAREIL ET PROCÉDÉ DE REMPLISSAGE DE RÉCIPIENTS

(84) Designated Contracting States:
AL AT BE BG CH CY CZ DE DK EE ES FI FR GB GR HR HU IE IS IT LI LT LU LV MC MK MT NL NO PL PT RO RS SE SI SK SM TR

(72) Inventor: **Parmar, Chandra**
Leeds, Yorkshire (GB)

(30) Priority: **26.10.2018 GB 201817437**
05.07.2019 GB 201909664

(74) Representative: **Wood, Graham**
Bailey Walsh & Co LLP
1 York Place
Leeds, LS1 2DR (GB)

(43) Date of publication of application:
29.04.2020 Bulletin 2020/18

(56) References cited:
EP-A2- 0 100 969 **EP-A2- 0 131 904**
WO-A2-02/090194 **ES-T3- 2 638 215**
US-A- 3 340 679 **US-A- 4 235 265**
US-A- 5 771 665 **US-A1- 2013 220 477**
US-A1- 2015 284 114 **US-B2- 7 430 843**

(73) Proprietor: **Parmar, Chandra**
Leeds, Yorkshire (GB)

EP 3 643 623 B1

Note: Within nine months of the publication of the mention of the grant of the European patent in the European Patent Bulletin, any person may give notice to the European Patent Office of opposition to that patent, in accordance with the Implementing Regulations. Notice of opposition shall not be deemed to have been filed until the opposition fee has been paid. (Art. 99(1) European Patent Convention).

Description

[0001] The invention to which this application relates is an apparatus and method which allows for the improved movement of flowable material, such as, but not exclusively, seeds, grains, powder, granules, foodstuffs, liquids, tablets or the like, into one or more containers and to allow a predefined quantity of the material to be dispensed into the container in a controlled manner. Typically, the predefined quantity will be sufficient to at least partially fill the container and more typically substantially fill the container.

[0002] Typically, once the container has been filled, the same can be moved so that an opening into the same is sealed, and may be cut or separated and, in one embodiment, the container can then form a retail pack or, in combination with other containers, a retail pack.

[0003] In many instances of use, it is desired to provide to an end-user, a quantity of a material in a known or predetermined amount so that the user can then use the material for an end purpose such as, for example, as part of a recipe, or the like or in a known amount for a medical purpose and where it is important that the said material is provided in a predetermined amount and/or avoids the need for the end-user to have to independently measure the quantity. In addition, or alternatively, it may be required to provide a desired number of material items such as, for example, a number of seeds or tablets which are to be provided as part of a retail pack at a particular price. Furthermore, it may be desired that the containers are of a particular size and there is a need to be able to accurately and repeatedly fill the container.

[0004] It is known to provide this form of container to end-users and conventionally a quantity of the material is poured into an opening into the container until the container is full. However, when attempts are made to do this on a larger scale, the process is found to be inefficient and can cause significant wastage of material.

[0005] It is also known to provide apparatus and a method which allows a plurality of said containers to be filled with the same material simultaneously and then allow the containers to be subsequently sealed, and may be cut or separated to form the retail pack. However, it is found that the apparatus and method of the conventional form, while suited to the filling of relatively small volume containers, is difficult to increase in capacity in terms of the number of containers which can be filled at any one time and/or the size of the containers.

[0006] US7430843 discloses a means by which material can be supplied into a bag to fill the same. The material which enters the bag can be liquid and/or solid and there is provided a filling pipe or a filling hopper. US2013220477, US2015284114, US5771665 and US3340579 do not disclose the use of the configuration of a filling channel and movement between the filling channel and container which is to be filled as a means of determining the volume of material which is to be dispensed into the container. Document EP100969 discloses

one form of apparatus for dispensing a liquid in a manner which allows a minimal leakage between the supply apparatus and the container being filled. As such the filling of containers with a flowable material is still regarded as problematic and is relatively inefficient and so increasing the cost of the final pack and the potential wastage of material is still relatively high.

[0007] An aim of the present invention is therefore to provide apparatus and a method which allows the filling of one containers, or a number of containers simultaneously and accurately so that each of the containers which are to be filled, can be confidently predicted to include the required quantity of the material to a predetermined amount prior to the container being sealed.

[0008] A further aim is to allow the apparatus and method to be performed accurately and repeatedly to thereby ensure that containers from different batches, will still be filled to the predetermined amount.

[0009] A yet further aim of the invention is to allow the apparatus to be adaptable in terms of the quantity of the material which is to be placed into the container so as to allow the apparatus to be used to fill containers of different sizes in terms of capacity and/or volume and also in terms of the amount of material which is required to be placed into the container.

[0010] In a first aspect of the invention there is provided apparatus for the provision of a predetermined amount of a flowable material in the form of a powder, particulate and/or plant material into at least one container cavity via an opening therein, said apparatus including a supply of the flowable material, a support means to support said at least one container and, intermediate the said supply and the said at least one container there is provided a filling assembly, said filling assembly including a channel for said at least one container, said channel having a first part with an entrance opening located at a surface of a reservoir in which the said supply is located so as to allow flowable material moved by a wiper blade in said reservoir, to move downwardly from the supply into the channel and a second part with an exit opening to allow the flowable material to flow from the channel and into the container cavity and characterised in that the apparatus includes movement means provided to cause relative movement between the at least one container and the reservoir with which said channel of the filling assembly is located to allow the said channel to be at least partially located within the container cavity when the flowable material is in the channel and a stop is provided to contact with the underside of the said reservoir when the reservoir is moved towards the container and so define, in conjunction with the contact of the exit opening of the channel with the base of said at least one container, the extent of axial movement of said first and second parts of the said channel and the volume of said channel and so define the quantity of the said flowable material dispensed into the said channel and subsequently dispensed into the at least one container from said channel.

[0011] In one embodiment, the movement means is

provided so as to achieve the change from the first position to the second position prior to the flowable material entering the channel. Typically, when the channel is in the second position, the flowable material is passed from the supply of the flowable material, typically held in a reservoir or hopper, into the entrance and flows through the channel to the exit so as to substantially fill the channel and in which the flowable material is trapped.

[0012] Typically, when the channel is full, the movement means causes the movement to the first position so as to remove the channel from the container and leave the flowable material in the container.

[0013] In one embodiment, the channel dimensions are selected to be such that when the same is full, it contains the predetermined amount of the flowable material which is desired to be placed into the container.

[0014] In one embodiment, different channels can be selectively located with the apparatus with the particular channel which is selected being dependent on the particular quantity of flowable material which is to be placed into the container in that instant of use.

[0015] In one embodiment, suitable channels are fitted to the apparatus so as to be used in conjunction with a particular container such that the amount of flowable material from the channel matches the quantity of material which is required to be deposited in the container.

[0016] In one embodiment, the channel is adjustable in its size or capacity so as to allow the same channel to be used but adjusted in size and position so as to suit the particular predetermined amount of flowable material and/or size of container in relation to which the same is to be used at that instant of time.

[0017] In one embodiment, the channel is provided in the form of a telescopic arrangement of tubes so as to allow relative sliding movement between said tubes and hence alter the capacity of the channel.

[0018] In one embodiment, the particular size of the channel is determined by the movement of the channel to the second position and in the setting of the distance of the channel entrance of the channel from the base of the container when the channel exit is in contact with the base of the container.

[0019] In one embodiment, the apparatus includes a stop which is located so as to define the extent of movement of the channel to the second position.

[0020] In one embodiment, the location of the stop is adjustable to thereby allow setting of the of the size of the channel.

[0021] In one embodiment the material can flow into the channel until the level of the material is substantially flush with the entrance and the said reservoir surface.

[0022] In one embodiment, the channel includes, or is located with a biasing means such as a plate or other weighting material which biases the channel exit towards contact with the base of the container to which the same is desired to be located when in the second position.

[0023] In one embodiment, the apparatus includes a plurality of channels in a predefined configuration and

each channel is then available so as to be able to be used to fill a container.

[0024] Typically, it is the channels which are moved between the first and second positions with respect to the containers and thereby allow the simultaneous filling of the containers with predetermined amounts of the flowable material.

[0025] Typically, once the containers have been filled, and the filling means withdrawn to the first position, the filled containers can be moved to a subsequent station at which the openings into the containers can be sealed and hence the flowable material contained within the container.

[0026] In one embodiment the apparatus includes means to impart vibration to the at least one container.

[0027] In a further aspect of the invention there is provided a method of filling a plurality of containers with predetermined amounts of flowable material in the form of a powder, particulate and/or plant material, said method comprising placing the flowable material in a reservoir, placing a plurality of containers, each of which has a cavity in which a predetermined quantity of the flowable material is to be received, in a configuration matching the configuration of a plurality of filling assembly channels located intermediate the containers and the reservoir such that the openings into the containers are aligned with a respective channel, and movement means cause relative movement between the reservoir and said plurality of channels located therewith and the containers from a first position to a second position in which an exit opening in the channels is located in a respective container cavity, using a wiper blade to move the flowable material from the reservoir into a first, entrance opening of a first part of the channels so as to allow the predetermined quantity of the flowable material, defined as the quantity of the material which is contained in the channel, to pass downwardly from the said reservoir through the first part of the channel into a second part of the channel in which the exit opening is formed and into the container cavity and moving the channels and containers apart once the predetermined quantity of flowable material has entered into the containers from the respective channels and characterised in that a stop is provided to contact with the underside of the said reservoir when the reservoir is moved towards the containers and so define, when the said exit opening contacts with the base of the container the extent of axial movement of said first and second parts of the said channel and hence volume of said channel and so define the quantity of the said flowable material dispensed into the containers from the respective channels.

[0028] In one embodiment, the method includes the steps of moving said containers once they have received the predetermined quantity of flowable material to allow an opening into the containers to be sealed and retain the flowable material in the container.

[0029] In one embodiment, the entrances lie substantially flush with the surface of the reservoir.

[0030] In one embodiment, the method includes the step of replacing the channels from the apparatus and installing a new set of channels which have a different dimension to those of the channels which have been replaced and thereby allow the apparatus to be adaptable in terms of the container sizes which can be filled with the predetermined amounts of material and for the predetermined amounts to be selectable.

[0031] In one embodiment, the method includes the steps of adjusting one or more control means such as stops, in order to allow the size of the channels and hence the predetermined amounts of material which can be held therein, to be adjusted.

[0032] In one embodiment, there is provided apparatus for the moving of a quantity of a flowable material into a container, said apparatus comprising location means for the said container which has a cavity into which the said quantity of flowable material is to be moved, a reservoir of said flowable material from which the said quantity of flowable material is obtained and moved into the container via a filling means through which the flowable material moves from the reservoir and into the cavity of the container, said filling means located, during the movement of the flowable material, at least partially within the cavity and wherein there is relative movement between the said container and the filling means once the flowable material quantity has been introduced into the cavity and during the dispensation of the said quantity of material.

[0033] In one embodiment, the relative movement is achieved by movement of the container relative to the filling means which, in one embodiment, is held stationary.

[0034] In one embodiment, the said movement of the container, is along an axis which is substantially parallel with, or is the same axis as, the longitudinal axis of the said filling means.

[0035] In one embodiment, the filling means includes two openings, a first, entrance, opening through which the flowable material enters the filling means from the reservoir and a second exit opening at the opposite end to the first opening through which the flowable material leaves the filling means and the said second opening is located in the cavity and intermediate the base of the container and the opening into the container during the movement of the flowable material into the container cavity thereby leaving a space between the second end of the filling means and the base of the cavity which allows part of the flowable material to fill the container cavity in that space.

[0036] In one embodiment, the relative movement between the filling means and the container, commences while the flowable material quantity is passing through the filling means so that flowable material may still be entering the container cavity to fill the same with the required quantity, whilst the container and the filling means are being moved apart.

[0037] Typically, once the said container has been moved away from the filling means and filled with the

required quantity of the flowable material, the container is moved along an axis so as to provide sufficient space for a new container to be introduced under the filling means and then the sequence of filling of the new container commences and is a repeat of the sequence for the previous container.

[0038] Typically, a plurality of containers are filled with respective quantities of flowable material at the same time and the location means allows the containers to be provided in a predetermined configuration which matches the configuration of a plurality of filling means so that there is provided a filling means for each of the said containers.

[0039] In one embodiment the size of the filling means in terms of shape and/or length is selected with respect to the quantity of the flowable material which is to be placed into the container and/or the dimensions of the container.

[0040] In one embodiment means are provided to impart vibration to the container, and hence level the flowable material and minimising "heaping" of the dispensed flowable material.

[0041] Specific embodiments of the invention are now described with reference to the accompanying drawings wherein:

Figure 1 illustrates in a schematic manner, a series of steps which can be followed using apparatus in accordance with one embodiment of the invention;

Figure 2a and 2b illustrate component parts of the adjustable channel means used in the embodiment of Figure 1;

Figure 3 illustrates in a schematic manner a second embodiment of the apparatus in accordance with the invention;

Figures 4a - 4c illustrate apparatus in accordance with one configuration;

Figure 5 illustrates the apparatus in accordance with the second configuration in relation to a first type of container;

Figure 6 illustrates the apparatus in the configuration of Figure 5 in use with a second type of container;

Figure 7a illustrates an embodiment of apparatus in accordance with the invention during the filling of the container with a quantity of material; and

Figure 7b illustrates a filled container.

[0042] Referring firstly to Figures 1, 2a and 2b, there is illustrated apparatus in accordance with the first embodiment of the invention and the method of use of the same.

[0043] The apparatus comprises in accordance with this embodiment, a hopper or reservoir 2 in which a quantity of a flowable material 4 is provided. The reservoir has a surface 6 and flush with the surface 6 there is provided an entrance opening 8 of a channel 10 which has an exit opening or openings 12. The apparatus also includes a support 14 on which there is located, in this case, one container 16 which is shown in cross-section. The purpose of the invention is to allow a predetermined quantity of the flowable material 4 to be introduced into the container 16 through the opening 17 in a controlled and managed manner so as to ensure that the required predetermined quantity of the material 4 is located in the container and the container can then be moved on for sealing and sale. In order to achieve this, then in the embodiment shown, in step 1, the first step is to operate a stop means 18 which is located on the surface 14 and which has a free end 20 which is selectively positionable as indicated by arrow 22. The variation in the position of the free end 20, is to determine the location of the entrance 8 of the channel 10 with respect to surface 14 and hence the base 24 of the container 16. This is achieved by adjusting the free end 22 required height so as to be contactable with the underside 26 of the surface 6 of the reservoir.

[0044] Once the position of the stop 18 has been selected with respect to the size of the container 16 and the quantity of flowable material to be located in the same, then there is provided relative movement between the channel 10 and the container 16 and in this embodiment, the relevant movement is achieved by movement of the reservoir and channel downwardly as indicated by arrow 28 so as to move the underside 26 of the surface 6 into contact with the free end 20 of the stop 18. This then determines the distance X from the entrance 8 of the channel to the base 24 of the container 16 and also adds the effect of moving the channel from the first position to the second position in which the exit 12 of the channel is in contact with the base 24 of the container. At this point therefore the hatched area of the channel 30 determines the available volume which can receive the flowable material 4 therein and as shown in step 3, the flowable material is moved into the channel 10 by the use of a wiper blade 32 which is moved as indicated by arrow 34 along the surface 6 and hence causes the flowable material to flow into a channel through the entrance 8 as indicated by arrow 36 in step 3. Thus, with the channel 10 filled, so the user can be certain that the amount of flowable material in the channel 10 is the same as the required predetermined amount the material 4 which is required to be located in the container and therefore, at this stage, and as shown in step 4, the reservoir 2 and channel 10 can be moved as indicated by arrow 38 in step 4 upwardly and away from the stop so as to move the apparatus to the first position once more.

[0045] It will be appreciated that as the position of the free end 20 of the stop 18, is adjustable, so there is a need for the channel to be adjustable and in this embodiment, this is achieved by providing the channel as having

first and second parts 40, 42 which are relatively slidably moveable along an access 44 so as to allow the volume 30 which is defined by the channel in the second position, to be adjustable. The first and second parts 40, 42 are shown in greater detail in Figures 2a and 2b and it will be appreciated that the first and second parts are provided as tubes which are slidably moveable in a telescopic manner and the first part has the entrance 8 defined therein and the second part has the exit 12 defined therein and one or both of the parts may include airholes 46 which allow the escape of any air and hence ensure that the volume 30 is always available for filling completely by the flowable material 4.

[0046] In one embodiment, biasing means can be provided in the form of a spring 48 or other biasing means such as a plate or weighted material can be provided which act on the lower part 42 of the channel in order to bias the same towards an extended position away from the first tube so as to ensure that the same always extends to the required length and hence the available volume of the channel is always as great as required for that particular use.

[0047] Figure 3 illustrates another embodiment of the invention in which the steps 2, 3 and 4 as described in Figure 1 can be performed so as to allow the material 4 to be moved into the channel 10 via the opening 8 and with the exit 12 being shown, when in the second position as shown in Figure 2 in contact with the base 24 of the container 16. However, in this case, the apparatus is used for filling of containers of the same size at all times and hence the channel 10 is formed of a one-piece and therefore is not required to be adjusted in length and furthermore, the stop 18 is not required to be used. However, the reservoir 2 and channel 10 are still required to be moved from a first position in which the exit 12 is raised from the base 24 of the container and a second position in which the exit 12 is in contact with the container as shown in Figure 3 and when in this position, the flowable material can be introduced into the channel 10 as illustrated by an arrow 36 to fill the same.

[0048] Figures 4a, 4b and 4c illustrate a first configuration of apparatus in accordance with the invention and, in this case, the channel is formed of two parts 40 and 42.

[0049] It will be appreciated that in this configuration, there is provided a common reservoir 2 which has a surface 6 in which there are provided a plurality of channel entrances 8 as illustrated in Figure 4c.

[0050] Once again, a stop is provided which allow the movement of the surface 6 with respect to the support 14 for a number of containers 16 to be selected and it will be shown that in this case, the containers are supported in the same configuration of 4 by 6 as are the channels 10 so that 24 containers can be filled simultaneously in accordance with this configuration of the apparatus.

[0051] The method filling the containers 10 simultaneously utilises the same steps as described with respect to Figure 1 and therefore will not be described again but

it will be appreciated that the current invention is adaptable and allows many different configurations of use to be achieved. Furthermore, in this example, there is shown in Figure 4a that a counterweight mechanism 50 can be utilised in order to bias and balance the operation of the movement means between the first and second position and further mechanical guidance may be provided to allow the guided movement between the reservoir and channels and the containers between the first and second positions.

[0052] It will be appreciated that the invention can be used with many different types of containers and Figures 5 and 6 illustrate a further embodiment of the apparatus in a different configuration and in which the same reference numerals as used previously, are used again for the same common components. It will also be appreciated that in this case, the containers and channels, are provided in a linear configuration along the axis 52 and that the containers are moved in stepped intervals along a support in the form of a conveyor system so as to allow the required number of containers to be located under the channels to be filled simultaneously. Furthermore, Figure 5 illustrates the manner in which the containers 16 can be of the "pot" configuration whilst in Figure 6, there are illustrated containers 16 in the form of bags which can be filled equally as easily as the pot containers in accordance with the invention.

[0053] In Figure 7a there is shown a cross section of a single container 102 for ease of illustration but more typically a plurality of containers will be filled at the same time and the containers are provided in a predetermined configuration. Each of the containers includes a base 106, sidewalls 104,108 and these define a cavity 110, and an opening 112 is provided which leads into the said cavity. The containers are provided in the required configuration on location means with their opening 112 positioned upwardly and typically under the filling apparatus 113. The filling apparatus includes a frame 114 which locates thereon, the filling means 116.

[0054] The filling means 116 has a first, entrance, opening 122 and an opposed, exit, opening 124 and in each case there is a known predetermined length 126, between the said openings and it will be appreciated that for different sized capacity containers different shaped and capacity filling means can be used than that shown in Figure 7a. Above and/or to one side of the entrance opening 122 of the filling means, there is provided a reservoir 128 of a flowable material, such as a powder, granules or the like. A movement means is provided to move at least some of the flowable material in said reservoir across the plate 129 in which the entrance openings 122 of the respective filling means 116 are located and thereby allow a quantity 130 of the flowable material to pass into the first, entrance, opening 122 into the filling means tube 116.

[0055] To commence filling, the container 102 is moved so that the cavity 110 is positioned so that the flowable material which enters the entrance opening 122

of the filling means 116, flows through the filling means tube 116 and into the cavity 110. As the filling means tube is of a predetermined size, then the amount of flowable material which is held in the filling means tube is known and thereby, once it has passed through into the container, the amount of the flowable material 110 in the cavity of the container is also known to be within a pre-defined range which is acceptable for the purpose.

[0056] Movement means are provided to allow the container 102, to be moved towards the filling means as indicated by arrow 132 to allow the same to be in position to be filled with the filling means tube 116 and exit opening 124 located in the cavity 110 and then, once the flow of the flowable material has commenced into the cavity of the container, or after all of the flowable material has entered the cavity, the container 104 is then moved away from the filling means as indicated by arrow 134 so as to allow the filled container to be moved away from the apparatus to a position as shown in Figure 7b in which the filling means tube 116 is removed from the cavity 110 hence leaving in the cavity 10 of the container 102 the required quantity 130 of the flowable material which typically will settle in the container cavity 110.

[0057] Typically, the opening 112 into the container 102 is then sealed and the same can be used, for example as a retail pack or medication pack or the like. A new set of empty containers 102 can then be introduced for filling and the sequence is repeated.

[0058] This embodiment therefore means that the exit opening 124 of the filling means tube 116 need not contact the base 106 of the cavity 110 and so there is a gap between the opening 124 and the base into which the flowable material flows from the filling means and the subsequent movement of the container away from the filling means then allows the remainder of the required quantity of the flowable material quantity 130 to leave the filling means tube 116 and flow into the container cavity 110 as illustrated in Figure 7b. It is believed that this arrangement minimises the risk of blockage of the flowable material in the filling means and also may reduce the time required to fill each cavity 110 of the container 102.

[0059] In one embodiment the container and/or support therefore and/or filling means 116 may be vibrated during filling to prevent "heaping" of the flowable material quantity 130 in the container cavity 110.

[0060] There is therefore provided in accordance with the invention, further improvements to apparatus for introducing predetermined quantities of a flowable material into a container and which can be provided of to allow a plurality of containers to be filled simultaneously and with a reduced risk of the flowable material from becoming stuck or blocked in the filling means as the exit opening 124 of the filling means tube 116 is not required to contact the base 116 of the container.

Claims

1. Apparatus for the provision of a predetermined amount of a flowable material in the form of a powder, particulate and/or plant material from a reservoir (2) into at least one container (16) cavity (110) via an opening (17) therein, said apparatus including a supply of the flowable material (4), a support means (14) to support said at least one container and, intermediate the said supply and the said at least one container there is provided a filling assembly, said filling assembly including a channel (10) for said at least one container, said channel having a first part (40) with an entrance opening (8) located at a surface (6) of a reservoir in which the said supply is located so as to allow flowable material moved by a wiper blade (32) in said reservoir, to move downwardly from the supply into the channel (10) and a second part (42) with an exit opening (12) part (42) slidably movable relative to the first part (40), such as to allow the flowable material to flow from the channel (10) into the container cavity and **characterised in that** the apparatus includes movement means provided to cause relative movement between the at least one container (16) and the reservoir with which said channel (10) of the filling assembly is located to allow the said channel to be at least partially located within the container cavity (110) when the flowable material (4) is in the channel and a stop (18) located with one part on the surface (14) and with the other part provided to contact with the underside (26) of the said reservoir when the reservoir is moved towards the container (16) and so define, in conjunction with the contact of the exit opening (12) of the channel (10) with a base (24) of said at least one container, the extent of axial movement of said first and second parts (40,42) of the said channel (10) and the volume of said channel and so define the quantity of the said flowable material (4) dispensed into the said channel (10) and subsequently dispensed into the at least one container (16) from said channel (10).
2. Apparatus according to claim 1 **characterised in that** the relative movement is along an axis which is substantially parallel with or is the same axis as, the longitudinal axis of the said channel (10).
3. Apparatus according to claim 1 **characterised in that** the movement means cause the channel (10) to be located in the container (16) such that the said exit opening (12) of the channel is located at the base (24) of the container cavity until the required quantity of the flowable material (4) which is to be placed into the container cavity is present in the channel.
4. Apparatus according to claim 1 **characterised in that** the movement means cause the channel (10) to be located in the container such that the said exit opening (12) of the channel is located intermediate the base (24) of the cavity and the container opening (17).
5. Apparatus according to any of the preceding claims **characterised in that** a plurality of containers (16) are simultaneously filled with respective quantities of flowable material and location means provide the containers in a predetermined configuration which matches the configuration of the plurality of filling means channels (10).
6. Apparatus according to any of the preceding claims **characterised in that** the size of the channels (10) in terms of shape and/or length is selected and/or adapted to define the particular quantity of the flowable material which is to be placed into the container at a particular use of the apparatus.
7. Apparatus according to claim 6 **characterised in that** the length of the channel (10) is adjustable.
8. Apparatus according to any of the preceding claims **characterised in that** the apparatus includes means to impart vibration to the at least one container.
9. Apparatus according to any of the preceding claims characterised in that the movement means is provided so as to move the said channel (10) from the first position to the second position at least partially in the second channel prior to the flowable material entering the channel.
10. Apparatus according to any of claims 1-8 **characterised in that** the movement means is provided to move the at least one container (16) towards the channel (10) exit opening prior to the flow of the flowable material through the channel (10), and away from the channel as the flowable material flows from, or after the flowable material has flowed from, the exit opening into the at least one container cavity (110) so as to leave the required quantity of the flowable material (4) in the container.
11. Apparatus according to any of the preceding claims **characterised in that** the location of the stop (18) is adjustable to reflect the required quantity of flowable material which is to be deposited in the container cavity and/or the size of the container.
12. A method of filling a plurality of containers (16) with predetermined amounts of flowable material (4) in the form of a powder, particulate and/or plant material, method put in practice by an apparatus according to any of the preceding claims, said method comprising placing the flowable material (4) in a reservoir, placing a plurality of containers (16), each of

which has a cavity (110) in which a predetermined quantity of the flowable material is to be received, in a configuration matching the configuration of a plurality of filling assembly channels (10) located intermediate the containers (16) and the reservoir such that the openings (17) into the containers (16) are aligned with a respective channel (10), and movement means cause relative movement between the reservoir and said plurality of channels located therewith and the containers from a first position to a second position in which an exit, opening (12) in the channels is located in a respective container cavity, using a wiper blade (32) to move the flowable material from the reservoir into a first, entrance opening (8) of a first part (40) of the channels so as to allow the predetermined quantity of the flowable material, defined as the quantity of the material which is contained in the channel (10), to pass downwardly from the said reservoir through the first part of the channel into a second part (42) of the channel in which the exit opening (12) is formed and into the container cavity and moving the channels and containers apart once the predetermined quantity of flowable material has entered into the containers from the respective channels and **characterised in that** a stop (18) is provided to contact with the underside (26) of the said reservoir when the reservoir is moved towards the containers (16) and so define, when the said exit opening (12) contacts with the base (24) of the container the extent of axial movement of said first and second parts (40,42) of the said channel and hence volume of said channel and so define the quantity of the said flowable material dispensed into the containers from the respective channels.

Patentansprüche

1. Vorrichtung zur Bereitstellung einer vorbestimmten Menge eines fließfähigen Materials in Form eines Pulver-, Partikel- und/oder Pflanzenmaterials aus einem Speicher (2) in wenigstens einen Behälter- (16) -hohlraum (110) über eine Öffnung (17) in ihm, wobei die genannte Vorrichtung aufweist: einen Vorrat an dem fließfähigem Material (4), eine Tragvorrichtung (14) zum Tragen des genannten wenigstens einen Behälters, und zwischen dem genannten Vorrat und dem genannten wenigstens einen Behälter eine Füllanordnung bereitgestellt ist, wobei die genannte Füllanordnung einen Kanal (10) für den genannten wenigstens einen Behälter beinhaltet, wobei der genannte Kanal einen ersten Teil (40) mit einer Eintrittsöffnung (8), die an einer Oberfläche (6) eines Speichers positioniert ist, in der der genannte Vorrat positioniert ist, damit sich fließfähiges Material, das von einem Schieberblatt (32) in dem genannten Speicher bewegt wird, abwärts aus dem Vorrat in den Kanal (10) bewegen kann, und einen zweiten Teil

(42) mit einer Austrittsöffnung (12) hat, wobei der Teil (42) relativ zu dem ersten Teil (40) verschiebbar bewegt werden kann, um das fließfähige Material aus dem Kanal (10) in den Behälterhohlraum fließen zu lassen, und **dadurch gekennzeichnet, dass** die Vorrichtung Folgendes beinhaltet: ein Bewegungsmittel, das zum Veranlassen relativer Bewegung zwischen dem wenigstens einen Behälter (16) und dem Speicher bereitgestellt ist, mit dem der genannte Kanal (10) der Füllanordnung positioniert wird, damit der genannte Kanal wenigstens teilweise in dem Behälterhohlraum (110) positioniert werden kann, wenn das fließfähige Material (4) in dem Kanal ist, und einen Anschlag (18), der mit einem Teil an der Oberfläche (14) positioniert ist und mit dem anderen Teil bereitgestellt ist, um mit der Unterseite (26) des genannten Speichers in Kontakt zu kommen, wenn der Speicher in Richtung auf den Behälter (16) bewegt wird, und so in Verbindung mit dem Kontakt der Austrittsöffnung (12) des Kanals (10) mit einem Boden (24) des genannten wenigstens einen Behälters das Ausmaß axialer Bewegung des genannten ersten und zweiten Teils (40, 42) des genannten Kanals (10) und das Volumen des genannten Kanals zu definieren und so die Menge des in den genannten Kanal (10) ausgegebenen und anschließend aus dem genannten Kanal (10) in den wenigstens einen Behälter (16) ausgegebenen genannten fließfähigen Materials (4) zu definieren.

2. Vorrichtung nach Anspruch 1 **dadurch gekennzeichnet, dass** die relative Bewegung an einer Achse entlang ist, die im Wesentlichen parallel mit der oder die gleiche(n) Achse wie die Längsachse des genannten Kanals (10) ist.
3. Vorrichtung nach Anspruch 1 **dadurch gekennzeichnet, dass** das Bewegungsmittel veranlasst, dass der Kanal (10) in dem Behälter (16) positioniert wird, so dass die genannte Austrittsöffnung (12) des Kanals sich am Boden (24) des Behälterhohlraums befindet, bis die erforderliche Menge des fließfähigen Materials (4), die in den Behälterhohlraum einzubringen ist, im Kanal vorhanden ist.
4. Vorrichtung nach Anspruch 1, **dadurch gekennzeichnet, dass** das Bewegungsmittel veranlasst, dass der Kanal (10) so in dem Behälter positioniert wird, dass die genannte Austrittsöffnung (12) des Kanals zwischen dem Boden (24) des Hohlraums und der Behälteröffnung (17) positioniert ist.
5. Vorrichtung nach einem der vorhergehenden Ansprüche, **dadurch gekennzeichnet, dass** eine Vielzahl von Behältern (16) gleichzeitig mit jeweiligen Mengen fließfähigen Materials gefüllt werden und Positionierungsmittel die Behälter in einer vorbestimmten Konfigurierung bereitstellen, die mit der

- Konfigurierung der Vielzahl von Füllmittelkanälen (10) übereinstimmt.
6. Vorrichtung nach einem der vorhergehenden Ansprüche, **dadurch gekennzeichnet, dass** die Größe der Kanäle (10) hinsichtlich Form und/oder Länge ausgewählt und/oder ausgeführt ist, um die jeweilige Menge des fließfähigen Materials zu definieren, die bei einer besonderen Verwendung der Vorrichtung in den Behälter einzubringen ist. 5
 7. Vorrichtung nach Anspruch 6, **dadurch gekennzeichnet, dass** die Länge des Kanals (10) verstellbar ist. 10
 8. Vorrichtung nach einem der vorhergehenden Ansprüche, **dadurch gekennzeichnet, dass** die Vorrichtung ein Mittel beinhaltet, um den wenigstens einen Behälter in Schwingung zu versetzen. 15
 9. Vorrichtung nach einem der vorhergehenden Ansprüche, **dadurch gekennzeichnet, dass** das Bewegungsmittel bereitgestellt ist, um den genannten Kanal (10) von der ersten Position auf die zweite Position wenigstens teilweise in dem zweiten Kanal zu bewegen, bevor das fließfähige Material in den Kanal eintritt. 20
 10. Vorrichtung nach einem der Ansprüche 1 bis 8, **dadurch gekennzeichnet, dass** das Bewegungsmittel zum Bewegen des wenigstens einen Behälters (16) vor dem Fließen des fließfähigen Materials durch den Kanal zur Kanal- (10)-austrittsöffnung hin und beim Fließen des fließfähigen Materials aus oder nach dem Fließen des fließfähigen Materials weg von der Austrittsöffnung in den wenigstens einen Behälterhohlraum (110) bereitgestellt ist, um die erforderliche Menge des fließfähigen Materials (4) in dem Behälter zurückzulassen. 25
 11. Vorrichtung nach einem der vorhergehenden Ansprüche, **dadurch gekennzeichnet, dass** die Position des Anschlags (18) verstellbar ist, um die erforderliche Menge von fließfähigem Material, das in dem Behälterhohlraum zu deponieren ist, und/oder die Größe des Behälters zu reflektieren. 30
 12. Verfahren zum Füllen einer Vielzahl von Behältern (16) mit vorbestimmten Mengen fließfähigen Materials (4) in Form eines Pulver-, Partikel- und/oder Pflanzenmaterials, wobei das Verfahren von einer Vorrichtung nach einem der vorhergehenden Ansprüche in die Praxis umgesetzt wird, wobei das genannte Verfahren aufweist: Einbringen des fließfähigen Materials (4) in einen Speicher, Einbringen einer Vielzahl von Behältern (16), die jeweils einen Hohlraum (110) haben, in welchem eine vorbestimmte Menge des fließfähigen Materials aufzu-

nehmen ist, in einer Konfigurierung, die mit der Konfigurierung einer Vielzahl von Füllanordnungskanälen (10) übereinstimmt, die zwischen den Behältern (16) und dem Speicher positioniert sind, so dass die Öffnungen (17) in die Behälter (16) auf einen jeweiligen Kanal (10) ausgerichtet sind und Bewegungsmittel eine relative Bewegung zwischen dem Speicher und der genannten Vielzahl von Kanälen, die an ihm positioniert sind, und der Behälter von einer ersten Position auf eine zweite Position veranlassen, in der eine Austrittsöffnung (12) in den Kanälen in einem jeweiligen Behälterhohlraum positioniert ist, Verwenden eines Schieberblatts (32), um das fließfähige Material aus dem Speicher in eine erste, Eintrittsöffnung (8) eines ersten Teils (40) des Kanals zu bewegen, um die vorbestimmte Menge des fließfähigen Materials, die als die Menge des Materials definiert ist, die in dem Kanal (10) enthalten ist, abwärts aus dem genannten Speicher durch den ersten Teil des Kanals in einen zweiten Teil (42) des Kanals, in dem die Austrittsöffnung (12) gebildet ist, und in den Behälterhohlraum hindurchlaufen zu lassen, und Auseinanderbewegen der Kanäle und Behälter, sobald die vorbestimmte Menge fließfähigen Materials aus den jeweiligen Kanälen in die Behälter eingetreten ist, und **dadurch gekennzeichnet, dass** ein Anschlag (18) bereitgestellt ist, um mit der Unterseite (26) des genannten Speichers in Kontakt zu kommen, wenn der Speicher zu den Behältern (16) hinbewegt wird, und so, wenn die genannte Austrittsöffnung (12) mit dem Boden (24) des Behälters in Kontakt kommt, das Ausmaß der axialen Bewegung der genannten ersten und zweiten Teile (40, 42) des genannten Kanals und somit das Volumen des genannten Kanals zu definieren und so die Menge des genannten fließfähigen Materials, die aus den jeweiligen Kanälen in die Behälter ausgegeben wird, zu definieren. 35

Revendications

1. Appareil pour la fourniture d'une quantité prédéterminée d'une matière fluable sous la forme d'une poudre, de particules et/ou de matière végétale à partir d'un réservoir (2) dans au moins une cavité (110) de contenant (16) via une ouverture (17) dans celui-ci, ledit appareil incluant une alimentation en matière fluable (4), un moyen de support (14) pour soutenir ledit au moins un contenant et, entre ladite alimentation et ledit au moins un contenant, est prévu un ensemble de remplissage, ledit ensemble de remplissage incluant un canal (10) pour ledit au moins un contenant, ledit canal ayant une première partie (40) avec une ouverture d'entrée (8) située au niveau d'une surface (6) d'un réservoir dans lequel ladite alimentation est située de sorte à permettre à la matière fluable, déplacée par une lame racleuse (32)

- dans ledit réservoir, de se déplacer vers le bas à partir de l'alimentation jusque dans le canal (10) et une deuxième partie (42) avec une partie (42) d'ouverture de sortie (12) mobile par coulissement relativement à la première partie (40), de telle sorte à permettre à la matière fluable de couler à partir du canal (10) jusque dans la cavité de contenant et **caractérisé en ce que** l'appareil inclut un moyen de mouvement prévu pour provoquer un mouvement relatif entre l'au moins un contenant (16) et le réservoir avec lequel ledit canal (10) de l'ensemble de remplissage est situé pour permettre audit canal d'être au moins situé partiellement au sein de la cavité de contenant (110) lorsque la matière fluable (4) se trouve dans le canal et un arrêt (18) situé avec une partie sur la surface (14) et avec l'autre partie prévue de manière à se mettre au contact de la face inférieure (26) dudit réservoir lorsque le réservoir est déplacé vers le contenant (16) et définir ainsi, en conjonction avec la mise en contact de l'ouverture de sortie (12) du canal (10) avec une base (24) dudit au moins un contenant, la portée du mouvement axial desdites première et deuxième parties (40, 42) dudit canal (10) et le volume dudit canal et définir ainsi la quantité de ladite matière fluable (4) distribuée dans ledit canal (10) et distribuée ultérieurement dans l'au moins un contenant (16) à partir dudit canal (10).
2. Appareil selon la revendication 1 **caractérisé en ce que** le mouvement relatif se fait le long d'un axe qui est substantiellement parallèle à ou est dans le même axe que, l'axe longitudinal dudit canal (10).
 3. Appareil selon la revendication 1 **caractérisé en ce que** le moyen de mouvement amène le canal (10) à être situé dans le contenant (16) de telle sorte que ladite ouverture de sortie (12) du canal soit située au niveau de la base (24) de la cavité de contenant jusqu'à ce que la quantité requise de matière fluable (4) qui est destinée à être placée dans la cavité de contenant soit présente dans le canal.
 4. Appareil selon la revendication 1 **caractérisé en ce que** le moyen de mouvement amène le canal (10) à être situé dans le contenant de telle sorte que ladite ouverture de sortie (12) du canal soit située entre la base (24) de la cavité et l'ouverture de contenant (17).
 5. Appareil selon n'importe lesquelles des revendications précédentes **caractérisé en ce qu'**une pluralité de contenants (16) sont remplis simultanément avec des quantités respectives de matière fluable et que des moyens de localisation disposent les contenants suivant une configuration prédéterminée qui concorde avec la configuration de la pluralité de canaux (10) des moyens de remplissage.
 6. Appareil selon n'importe lesquelles des revendications précédentes **caractérisé en ce que** la taille du canal (10) en termes de forme et/ou de longueur est sélectionnée et/ou adaptée pour définir la quantité particulière de matière fluable qui est destinée à être placée dans le contenant à une utilisation particulière de l'appareil.
 7. Appareil selon la revendication 6 **caractérisé en ce que** la longueur du canal (10) est ajustable.
 8. Appareil selon n'importe lesquelles des revendications précédentes **caractérisé en ce que** l'appareil inclut un moyen pour imprimer une vibration à l'au moins un contenant.
 9. Appareil selon n'importe lesquelles des revendications précédentes **caractérisé en ce que** le moyen de mouvement est prévu de sorte à déplacer ledit canal (10) à partir de la première position jusqu'à la deuxième position au moins partiellement dans le deuxième canal avant que la matière fluable n'entre dans le canal.
 10. Appareil selon n'importe lesquelles des revendications 1 à 8 **caractérisé en ce que** le moyen de mouvement est prévu pour déplacer l'au moins un contenant (16) vers l'ouverture de sortie du canal (10) avant l'écoulement de la matière fluable à travers le canal (10), et s'éloigner du canal dès que la matière fluable s'écoule à partir de, ou après que la matière fluable se soit écoulée à partir de, l'ouverture de sortie jusque dans l'au moins une cavité de contenant (110) de sorte à laisser la quantité requise de matière fluable (4) dans le contenant.
 11. Appareil selon n'importe lesquelles des revendications précédentes **caractérisé en ce que** l'emplacement de l'arrêt (18) est ajustable afin de refléter la quantité requise de matière fluable qui est destinée à être déposée dans la cavité de contenant et/ou la taille du contenant.
 12. Procédé de remplissage d'une pluralité de contenants (16) avec des quantités prédéterminées de matière fluable (4) sous la forme d'une poudre, de particules et/ou de matière végétale, le procédé étant mis en pratique par un appareil selon n'importe lesquelles des revendications précédentes, ledit procédé comprenant le fait de placer la matière fluable (4) dans un réservoir, le fait de placer une pluralité de contenants (16), dont chacun a une cavité (110) dans laquelle une quantité prédéterminée de matière fluable est destinée à être reçue, dans une configuration concordant avec la configuration d'une pluralité de canaux (10) de l'ensemble de remplissage situés entre les contenants (16) et le réservoir de telle sorte que les ouvertures (17) dans les conte-

nants (16) soient alignées avec un canal (10) respectif, et des moyens de mouvement provoquent un mouvement relatif entre le réservoir et ladite pluralité de canaux situés avec celui-ci, et les contenants à partir d'une première position jusqu'à une deuxième position dans laquelle une ouverture de sortie (12) dans les canaux est située dans une cavité de contenant respective, le fait d'utiliser une lame racleuse (32) pour déplacer la matière fluable à partir du réservoir dans une première ouverture (8) d'entrée d'une première partie (40) des canaux de sorte à permettre à la quantité prédéterminée de matière fluable, définie comme étant la quantité de matière qui est contenue dans le canal (10), de passer vers le bas à partir dudit réservoir à travers la première partie du canal jusque dans une deuxième partie (42) du canal dans laquelle l'ouverture de sortie (12) est formée et jusque dans la cavité de contenant et le fait de déplacer les canaux et les contenants en écartement une fois que la quantité prédéterminée de matière fluable est entrée dans les contenants à partir des canaux respectifs et **caractérisé en ce qu'**un arrêt (18) est prévu pour se mettre au contact de la face inférieure (26) dudit réservoir lorsque le réservoir est déplacé vers les contenants (16) et définir ainsi, lorsque ladite ouverture de sortie (12) se met au contact de la base (24) du contenant, la portée d'un mouvement axial desdites première et deuxième parties (40, 42) dudit canal et par conséquent le volume dudit canal et définir ainsi la quantité de ladite matière fluable distribuée dans les contenants à partir des canaux respectifs.

5

10

15

20

25

30

35

40

45

50

55

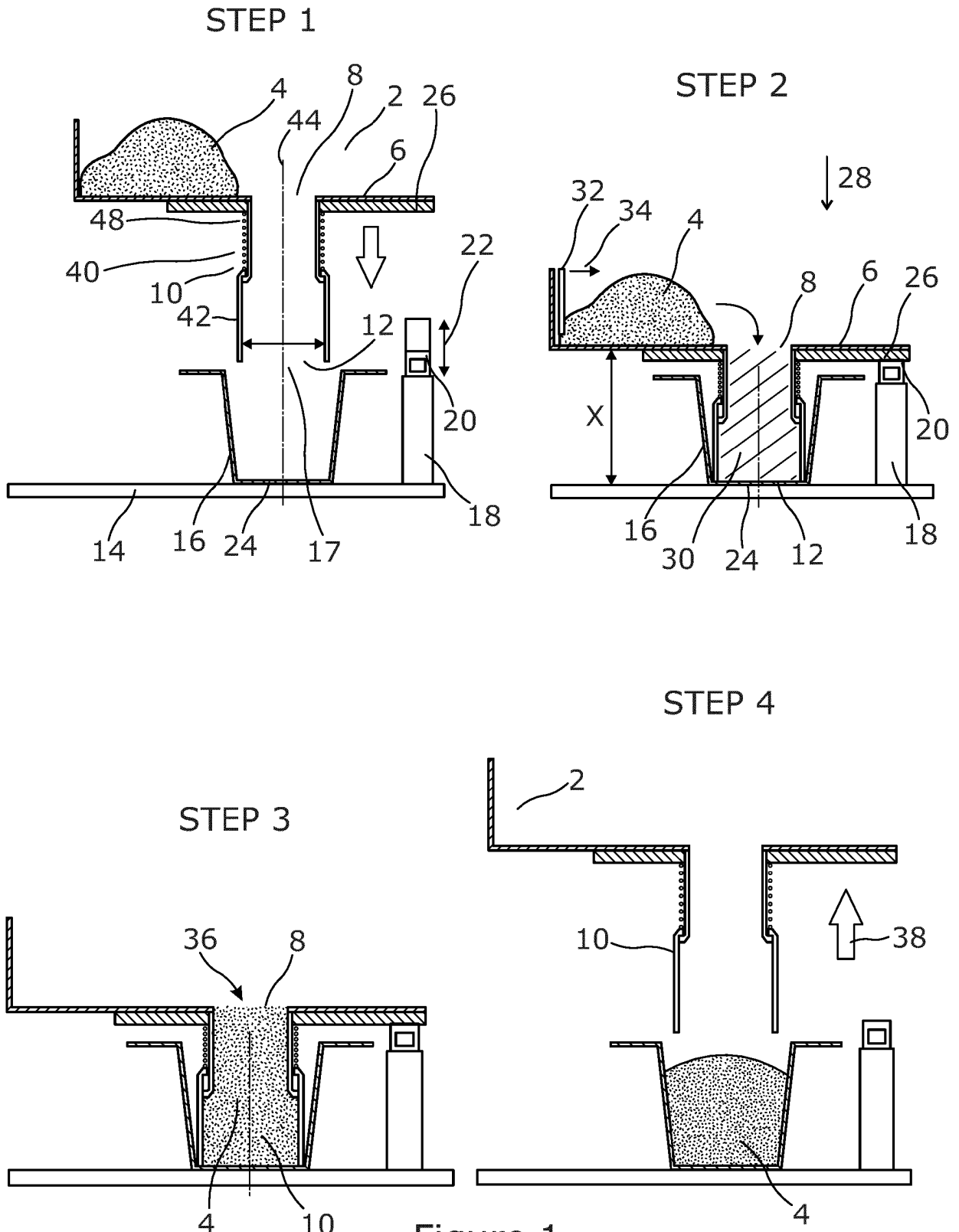

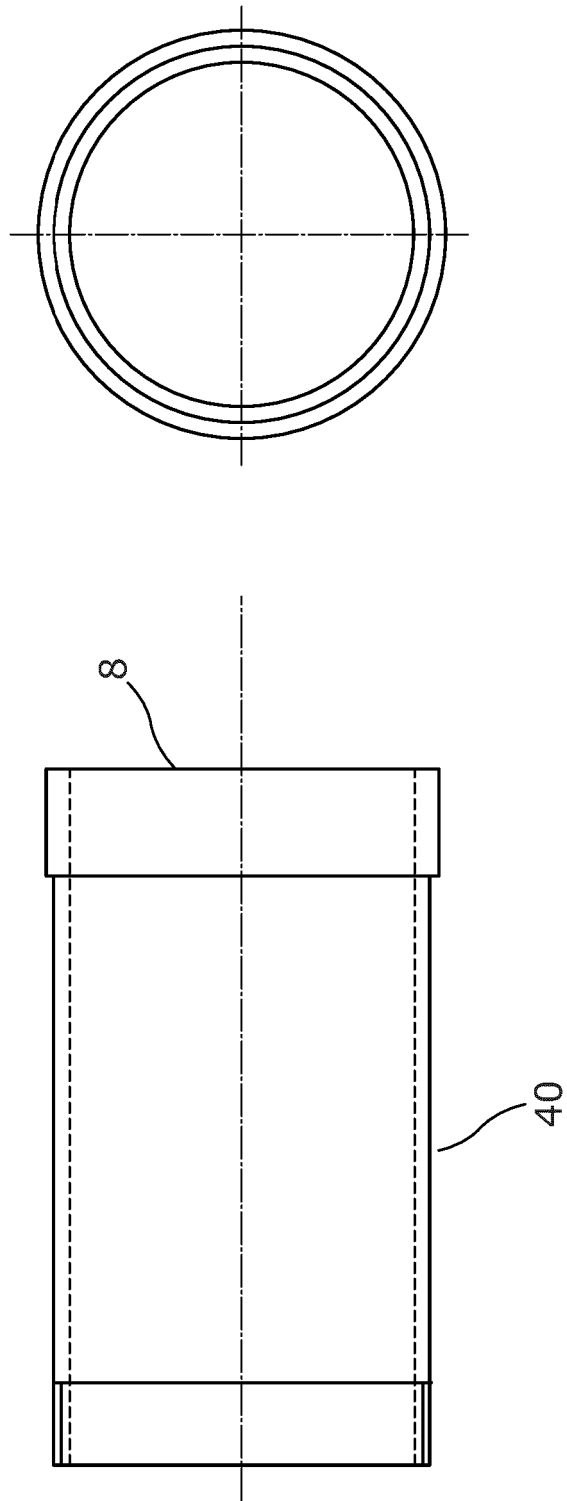

Figure 2a

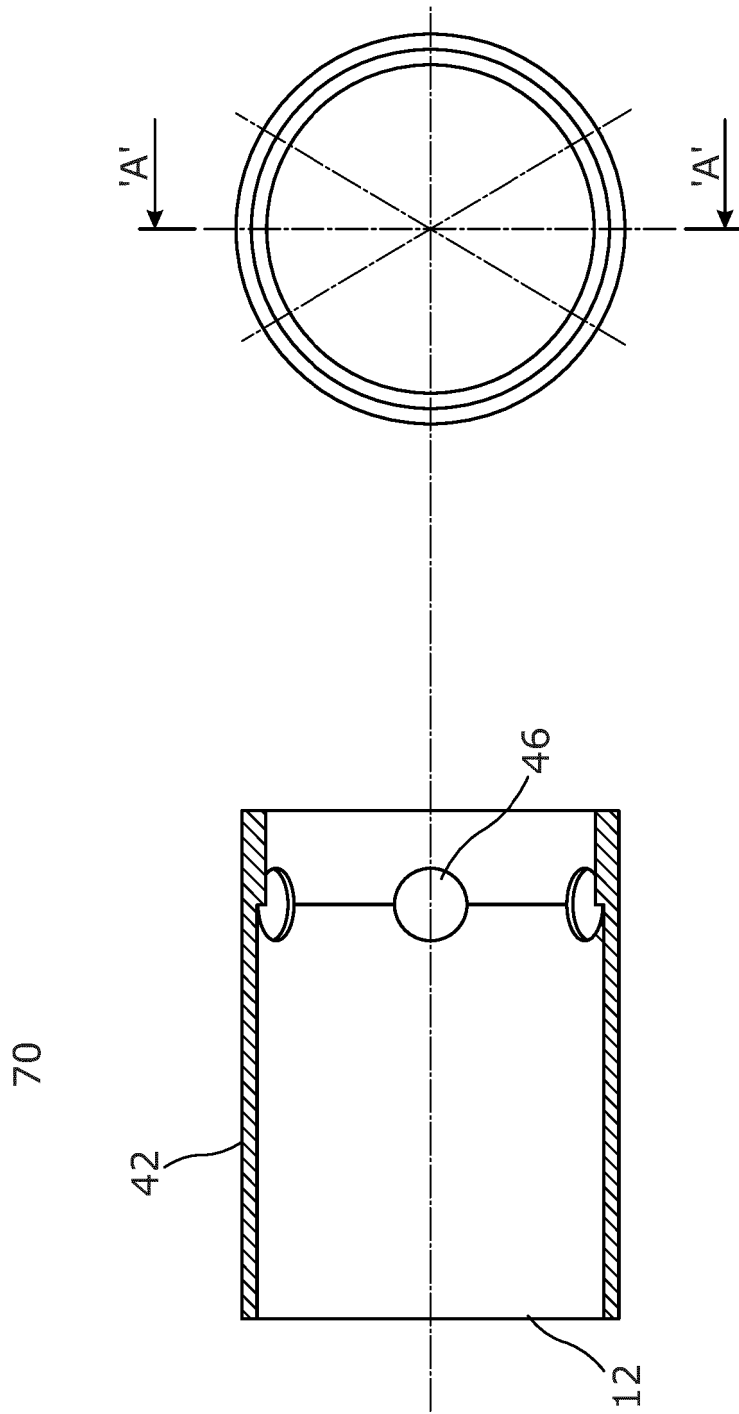

Figure 2b

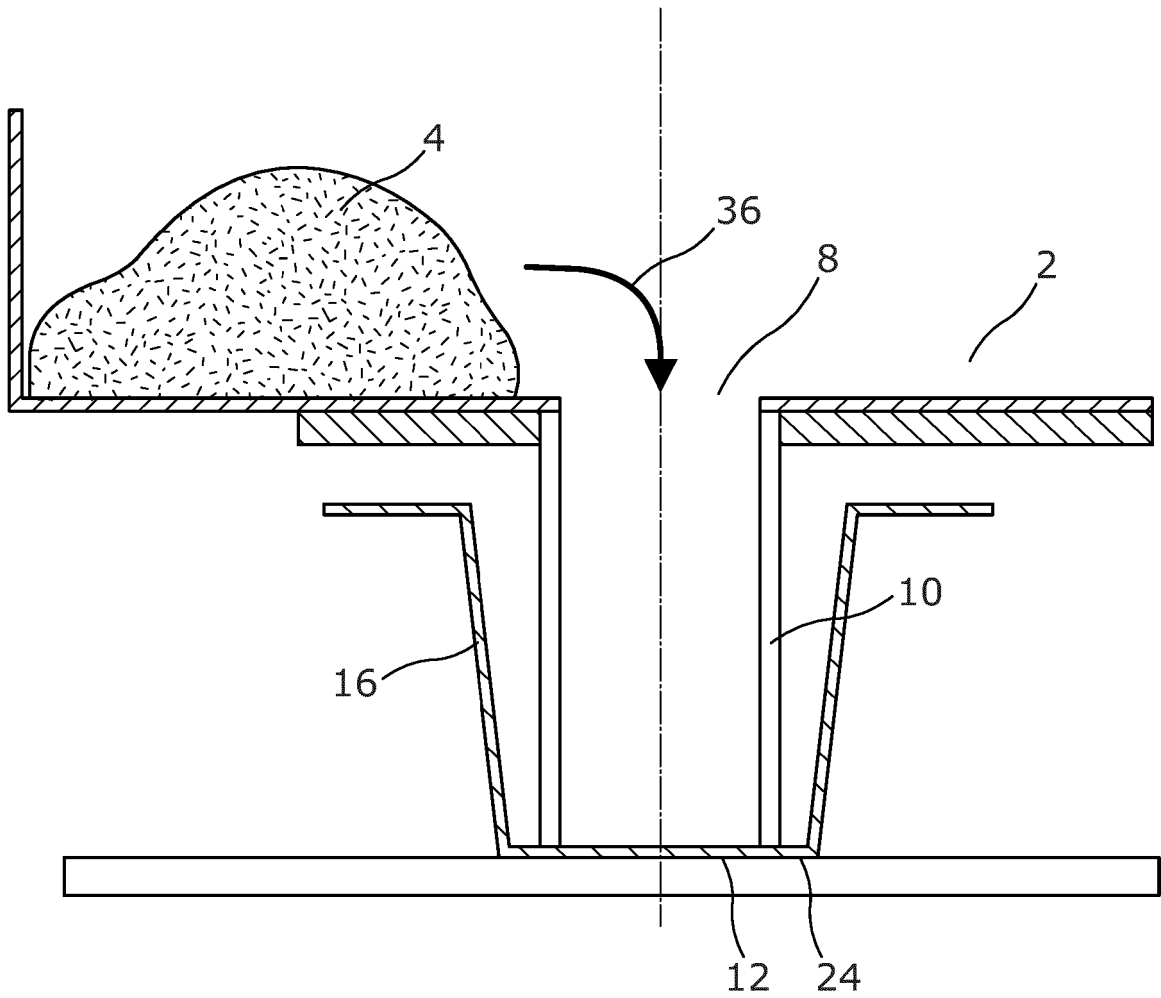

Figure 3

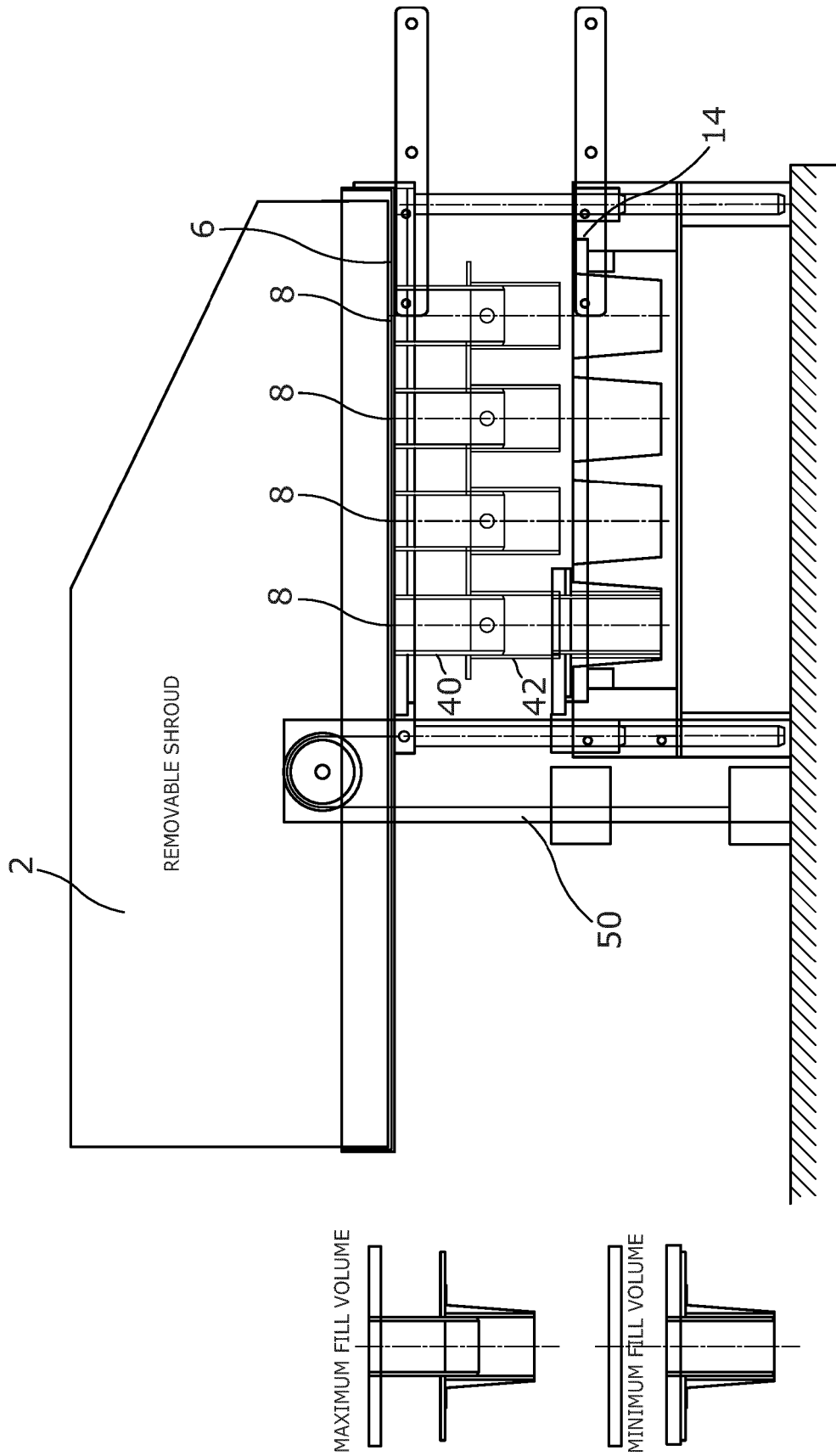

Figure 4a

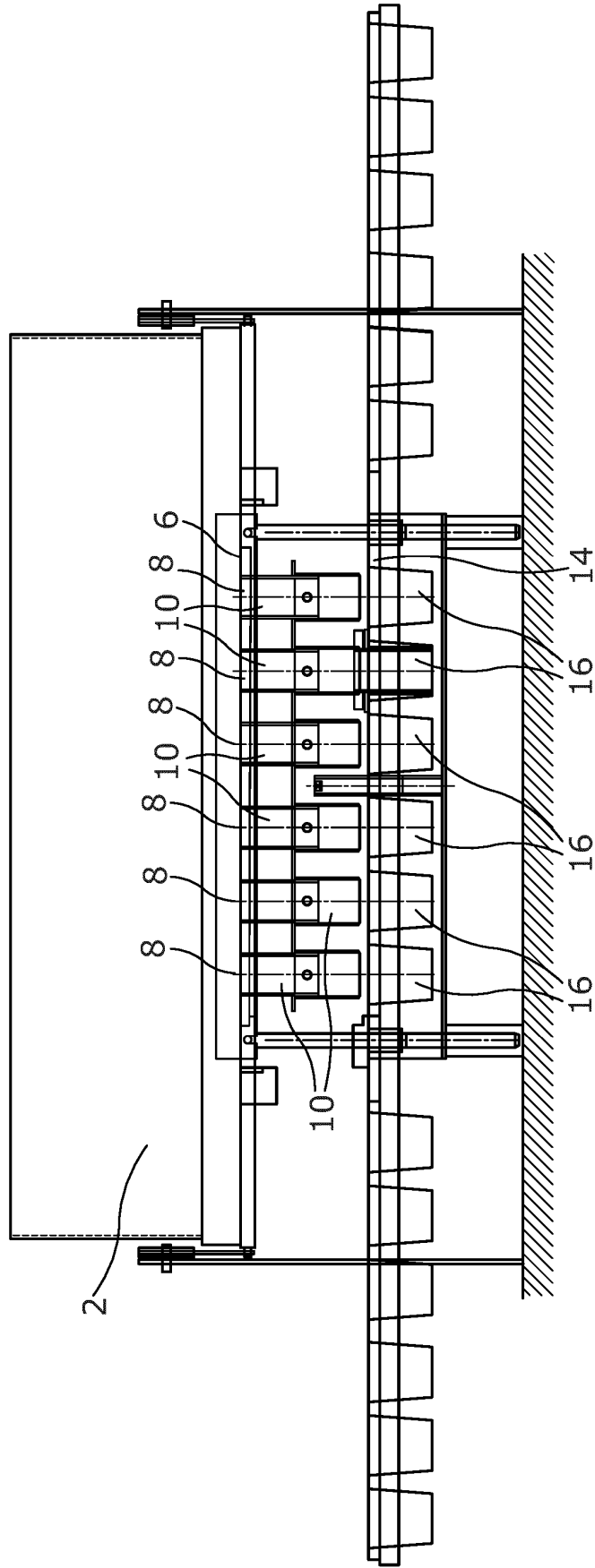

Figure 4b

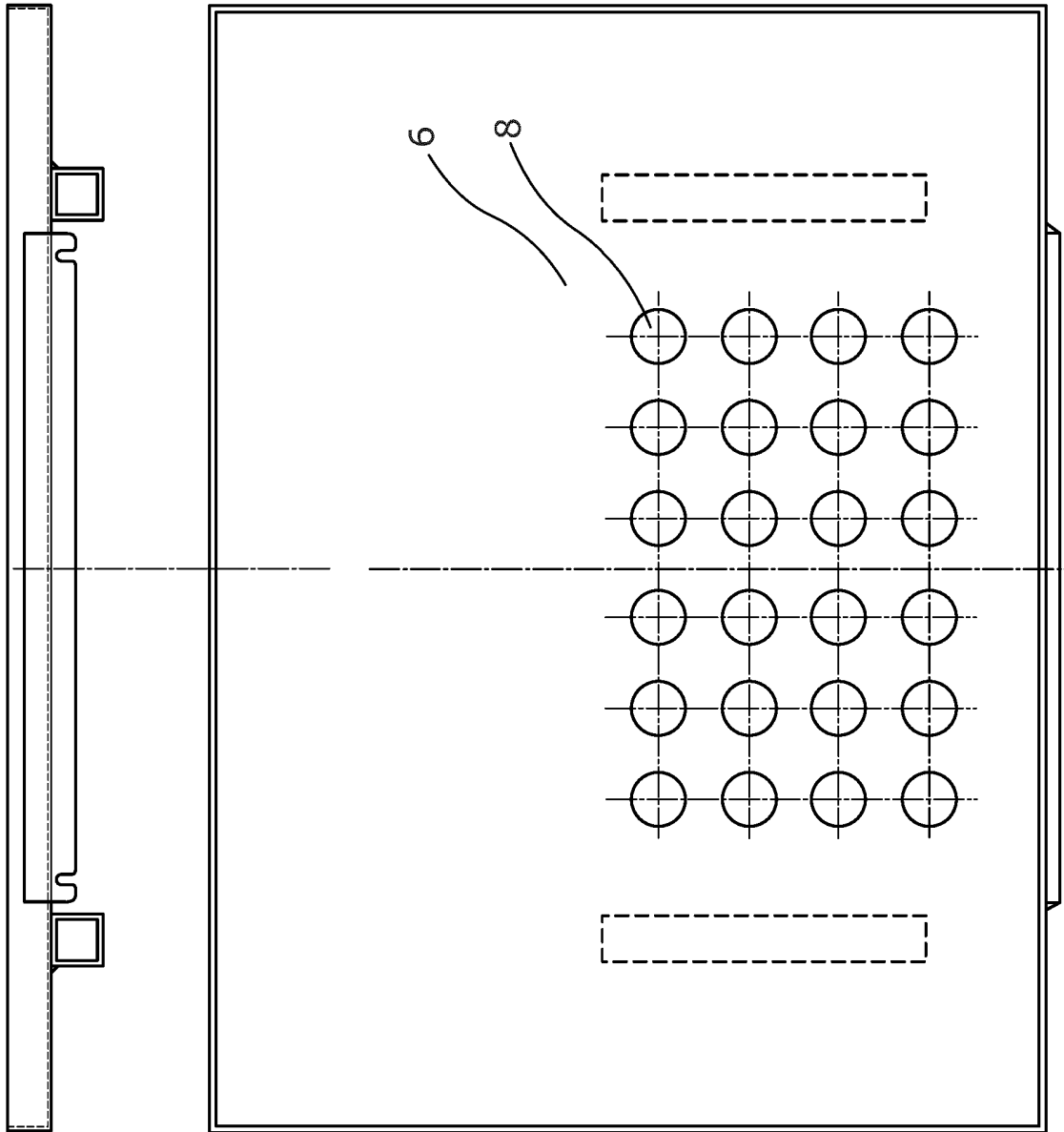
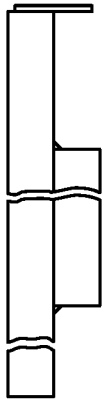

Figure 4c

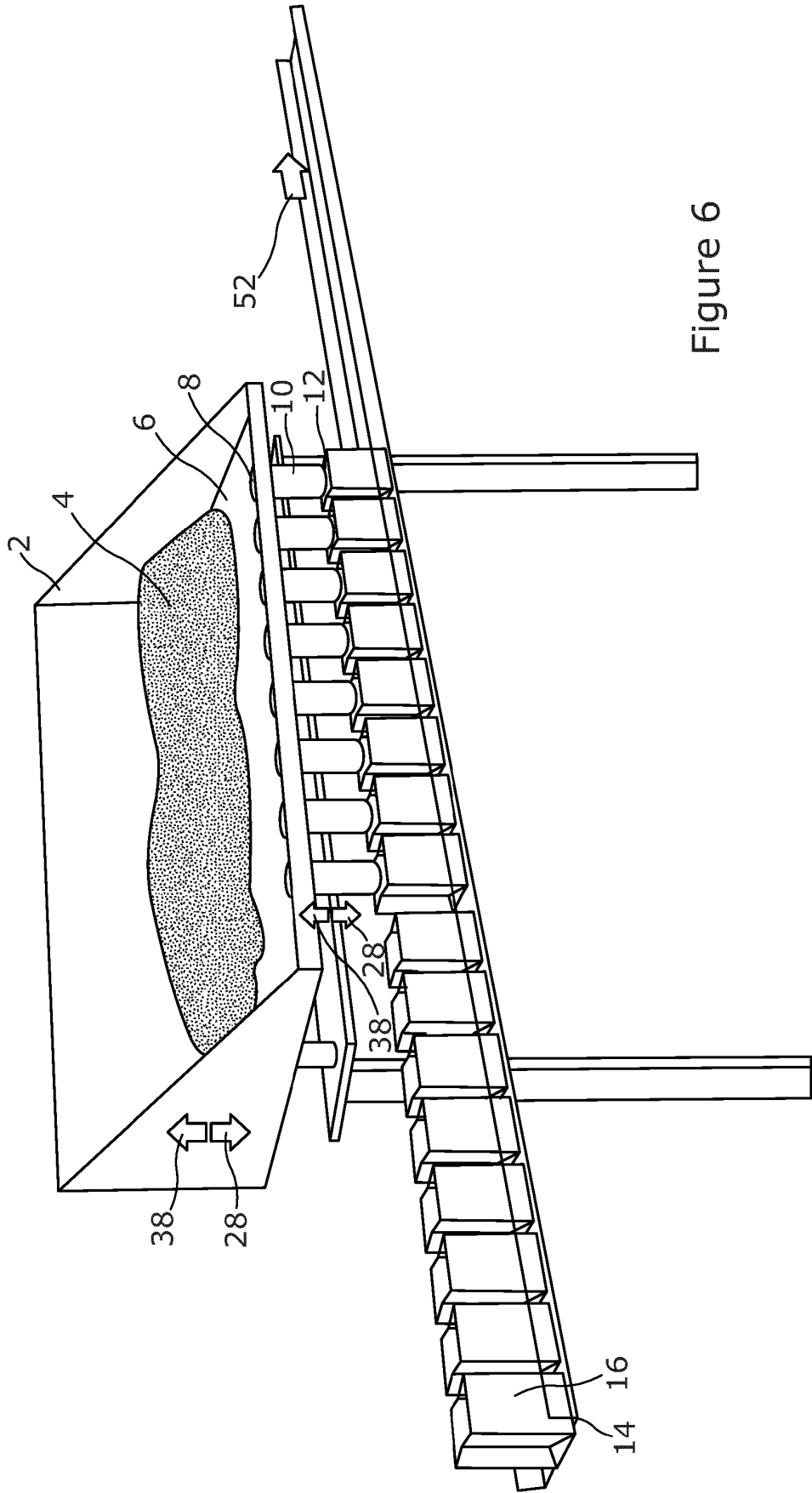

Figure 6

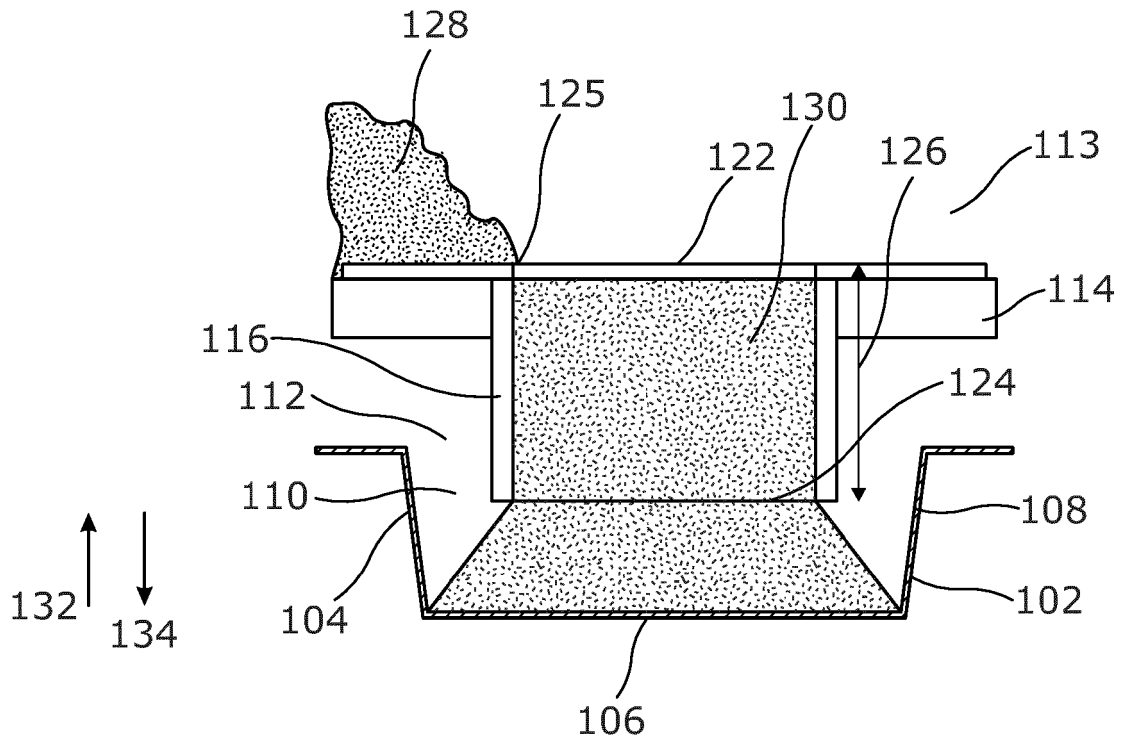

Figure 7a

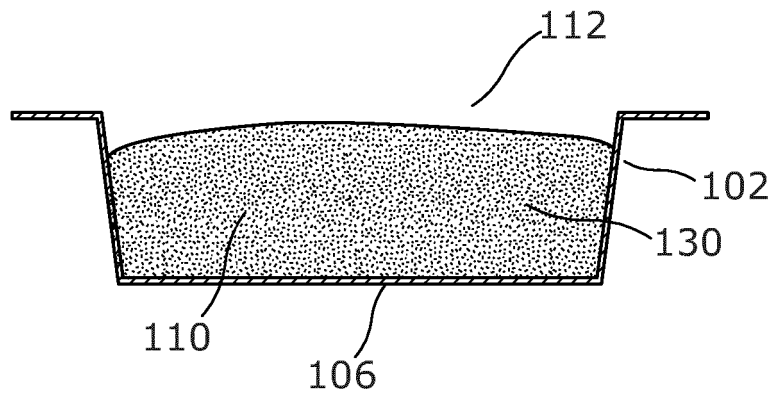

Figure 7b

REFERENCES CITED IN THE DESCRIPTION

This list of references cited by the applicant is for the reader's convenience only. It does not form part of the European patent document. Even though great care has been taken in compiling the references, errors or omissions cannot be excluded and the EPO disclaims all liability in this regard.

Patent documents cited in the description

- US 7430843 B [0006]
- US 2013220477 A [0006]
- US 2015284114 A [0006]
- US 5771665 A [0006]
- US 3340579 A [0006]
- EP 100969 A [0006]