



(11) **EP 3 643 638 B1**

(12) **EUROPEAN PATENT SPECIFICATION**

(45) Date of publication and mention of the grant of the patent:

09.03.2022 Bulletin 2022/10

(21) Application number: **18201797.0**

(22) Date of filing: **22.10.2018**

(51) International Patent Classification (IPC):

B65D 71/00 ^(2006.01) **A47F 5/11** ^(2006.01)

(52) Cooperative Patent Classification (CPC):

A47F 5/11; B65D 71/0096; B65D 2571/00037; B65D 2571/00043; B65D 2571/00055

(54) **TRANSPORT UNIT FOR FOODSTUFF PRODUCTS**

TRANSPORTEINHEIT FÜR LEBENSMITTELPRODUKTE

UNITÉ DE TRANSPORT POUR PRODUITS ALIMENTAIRES

(84) Designated Contracting States:

AL AT BE BG CH CY CZ DE DK EE ES FI FR GB GR HR HU IE IS IT LI LT LU LV MC MK MT NL NO PL PT RO RS SE SI SK SM TR

(43) Date of publication of application:

29.04.2020 Bulletin 2020/18

(73) Proprietor: **Soremartec S.A.**

2633 Senningerberg (LU)

(72) Inventor: **Kwecien, Tomasz**

96-100 Skiernie (PL)

(74) Representative: **Frontoni, Stefano**

Buzzi, Notaro & Antonielli d'Oulx S.p.A.

Corso Vittorio Emanuele II, 6

10123 Torino (IT)

(56) References cited:

DE-U1- 29 603 566

FR-A1- 2 539 386

US-A- 4 567 981

US-A1- 2017 247 156

US-A1- 2018 244 431

Note: Within nine months of the publication of the mention of the grant of the European patent in the European Patent Bulletin, any person may give notice to the European Patent Office of opposition to that patent, in accordance with the Implementing Regulations. Notice of opposition shall not be deemed to have been filed until the opposition fee has been paid. (Art. 99(1) European Patent Convention).

EP 3 643 638 B1

Description

[0001] The present invention relates to a transport unit for foodstuff products.

[0002] In particular, the present invention regards a transport unit of a pallet type, i.e., of the type comprising:

- a pallet or similar supporting structure; and
- a series of stacked supports, arranged on which are the products and which are carried by the aforesaid pallet.

[0003] Such a unit is designed for the transport of products, for example from a production site to a sales point, passing through warehouses. US4567981 discloses an example of transport unit known in the art.

[0004] In this context, the object of the present invention is to provide a transport unit that will moreover be suited for displaying the products at a sales point.

[0005] The object of the present invention is also to meet one or more of the following needs:

- providing ample surfaces for representing the brand and advertisements;
- providing a protection for the products in regard to any possible impact during transport; and
- providing a simple, low-cost, structure that can be assembled in a simple and fast way.

[0006] The transport unit according to the present invention is characterized in that it presents the features recalled in Claim 1.

[0007] Further characteristics and advantages of the invention will emerge clearly from the ensuing description, with reference to the annexed drawings, which are provided purely by way of non-limiting example and in which:

- Figure 1 illustrates a preferred embodiment of the unit described herein, according to an axonometric view;
- Figure 2 illustrates a single empty tray of the transport unit of Figure 1; and
- Figure 3 illustrates a panel or sheet out of which the tray of Figure 2 is made.

[0008] In the ensuing description, various specific details are illustrated, aimed at providing an in-depth understanding of the embodiments. The embodiments may be obtained without one or more of the specific details, or with other methods, components, or materials, etc. In other cases, known structures, materials, or operations are not illustrated or described in detail so that various aspects of the embodiment will not be obscured.

[0009] The references used herein are only provided for convenience and hence do not define the sphere of protection or the scope of the embodiments.

[0010] As already referred to above, the transport unit

described herein, designated in the figures by the reference number 10, is of a pallet type, comprising:

- a pallet 1 or similar supporting structure; and
- a series of supports 2 stacked on top of one another, arranged on which are the products P and which are carried by the pallet 1.

[0011] It should be noted that by the term "pallet" is here meant the type of support without any limitation as regards format or dimensions, so that the above term may include, for example, half pallets or quarter pallets.

[0012] For the reasons that will become evident in what follows, the products P preferably have rigid packagings, for example made of glass, plastic, metal, as well as paper or cardboard.

[0013] In a conventional way, the above unit is designed for the transport of products, for example from a production site to a sales point, passing through warehouses.

[0014] In particular, the unit 10 is prearranged for being moved, within an industrial plant or a warehouse, using specific equipment, such as forklift trucks, pallet trolleys, etc.

[0015] According to an important characteristic, the transport unit described herein is, moreover, designed to be used as structure for the display of the products in the sales point.

[0016] For this purpose, as will be seen in detail in what follows, the transport unit described herein has a configuration that renders clearly visible the products and enables communication to the consumer.

[0017] It should be noted that the aforesaid configuration derives from the particular structure of the unit, so that it is ready for a use as display unit already from when it is assembled for transport of the products. Clearly, this characteristic affords the advantage that it is possible to arrange the transport unit directly in the area of sale or display of the products, without any need to carry out any preparatory activity.

[0018] To return to the structure of the transport unit described herein, the aforesaid supports 2 are constituted by trays, each of which has a bottom 22 and side walls 24 that surround the bottom and which are characterized in that they have a small height as compared to the height of the products P, preferably less than half the height of the latter.

[0019] The trays 2 containing the products P are prearranged for being stacked on top of one another according to a condition in which the bottom of each tray that overlies another tray of the stack, rests directly on the products carried by the latter so that the weight of the stack of products is supported by the products themselves.

[0020] In view of the above arrangement of the products, the trays 2 do not require a particularly rigid and strong structure.

[0021] The stack of trays 2 containing the products P

rests directly on the top surface 1A of the pallet 1.

[0022] In a way in itself conventional, the pallet 1 has two resting feet 1B set at a distance from one another to enable insertion of forks or equivalent members of the means for handling goods normally used in industry and logistics. Preferably, the pallet 1 is made of plastic or wood, or cardboard material.

[0023] The transport unit described herein further comprises a covering panel 4, which is prearranged for covering preferably two or three sides of the stack of trays 2.

[0024] In various preferred embodiments, as in the one illustrated, the panel 4 has dimensions such as to identify three distinct portions 4A, 4B, 4C, which are connected together by two folding lines (not visible), and are prearranged for covering, respectively, the rear face and the two lateral faces of the stack of trays 2. Preferably, the height of the panel 4 is such that its edge terminates at the same level of the top end of the products of the top tray 2, or else above it.

[0025] In various preferred embodiments, as in the one illustrated, the transport unit 10 comprises a band 6, which envelops the bottom region of the covering panel 4 and the corresponding parts of the stack of trays 2, and is anchored to the pallet 1. In various preferred embodiments, as in the one illustrated, the band 6 is in particular provided with connection portions 62 that project downwards and fit into corresponding seats made in the pallet 1.

[0026] The band 6 performs the multiple functions of communication to the consumer, protection from impact (during transport and at the sales point), and support for the covering panel 4.

[0027] In view of the foregoing, the transport unit described herein hence has at least one side for display of the products, and at least one side for presentation of the brand or of advertisements.

[0028] In various preferred embodiments, as in the one illustrated, the unit 10 has, in particular, the front side A1, displayed on which are the products, and the two sides A2 and the rear side A3, positioned in which is the covering panel 4, which may present wordings or images on each of its portions 4A, 4B, and 4C.

[0029] To return to the trays 2, these are provided with corner protections 28 for protecting the products, obtained at least on their side walls that are to face the display side A1.

[0030] As will be seen in detail in what follows, the protections 28 are defined by the same sheet or panel that constitutes the bottom 22 and the side walls 24 of the individual trays.

[0031] On each tray the corner protections are provided on all four corners.

[0032] The above protections have the function of protecting the products from any possible impact during transport of the unit 10, as well as inside the sales point, for example from possible impact by shopping trolleys used in the sales point.

[0033] The positioning of these protections at the cor-

ners stems from the fact that the corners of the stack of trays 2 represent in effect the points that are subject to a higher risk of damage during transport (or at the sales point), and, moreover, from the fact that in these positions they do not hinder visibility of the products P arranged on the individual trays.

[0034] The protections 28 are constituted by wall portions having a greater height, which are provided at the opposite ends of the respective side wall.

[0035] The aforesaid portions extend on top of and underneath the bottom 22 of the tray, so as to constitute a protection in regard both to the products carried by the tray itself and to the products carried by the underlying tray.

[0036] As mentioned above, the tray 2 and the corresponding corner protections 28 are constituted by a single folded sheet, for example a sheet of paperboard or corrugated cardboard.

[0037] By way of example, Figure 3 illustrates a sheet obtained according to a paperboard-manufacturing process, which has a pre-set contour and predefined folding lines (i.e., creases) so that the tray 2 illustrated in Figures 1 and 2 can be assembled in only one way.

[0038] With reference to Figure 3, in general, the sheet shown for constructing a tray for the transport unit described herein, comprises a central portion 202, designed to define the bottom 22 of the tray, and at least two portions 204 that can be folded with respect to one another, connected to each side of the central portion 202, for defining double lateral walls 24. The two portions 204 designed to define a single double lateral wall are fixed via slotting in the condition where they are folded against one another; for example, as in the embodiment illustrated, the outer portion 204 may present projecting tabs 204A at its end edge, which are to fit into corresponding slots 202' provided on the central portion 202.

[0039] As has been seen above, the protections 28 are provided at all four corners of the tray and be defined by its side walls.

[0040] The aforesaid protections are defined by just two portions 204, which are directly connected to the central portion 202 and are located in positions opposite to the central portion.

[0041] In particular, in each of these portions 204 the protections 28 are defined by two widened ends 205 that have a generic quadrangular profile and are positioned at opposite corners of the sheet. Each of the aforesaid ends has a predefined folding line 205', to be folded in the corresponding angular configuration envisaged.

[0042] In addition to the slotting arrangements described above, the sheet 200 may be fixed in its folded configuration to define the tray 2 with the aid of glue.

[0043] Preferably, also the covering panel 4 and the band 6 are both formed by a respective folded sheet of paperboard or corrugated cardboard.

[0044] In the light of what has been said above, the transport unit described herein is assembled directly in the industrial production plant, and in the configuration

that has been described may be used for the transport of products from the industrial plant to the sales point.

[0045] Thanks to the characteristics that have been highlighted, at the sales point, the unit may then be directly positioned in the sales area.

[0046] Of course, without prejudice to the principle of the invention, the details of construction and the embodiments may vary, even significantly, with respect to what has been illustrated herein purely by way of non-limiting example, without thereby departing from the scope of the invention, as defined by the annexed claims.

Claims

1. A transport unit (10) for products (P), in particular foodstuff products, comprising:

- a pallet (1) or similar supporting structure; and
- a series of supports (2) stacked on top of one another, arranged on which are said products (P) and which are carried by said pallet (1), wherein
- said supports are constituted by trays (2) that contain said products (P) and are stacked on top of one another, said trays each comprising: a bottom (22), on which said products rest, and side walls (24), which surround said bottom (22) and have a small height with respect to said products (P), so as to render visible a prevalent part of said products (P); and
- said unit (10) comprises at least one covering panel (4) that covers at least one side of said stack of trays (2) and leaves, instead, exposed at least one side (A1) for display of said products; said unit being **characterized in that** said trays (2) are each provided with corner protections (28) at least at said side (A1) for display of said products,

wherein said protections (28) of said trays (2) are constituted by wall portions of two of said side walls (24), which have a greater height and are obtained at the opposite ends of the respective wall, and wherein said wall portions extend on top of and underneath the bottom (22) of the respective tray, so as to constitute a protection in regard both to the products carried by the respective tray and to the products carried by the underlying tray, wherein each tray is constituted by a single folded sheet, wherein said sheet comprises a central portion (202), designed to define the bottom (22) of the tray, and at least two portions (204) that are folded with respect to one another, connected to each side of the central

portion (202), for defining double lateral walls (24), the two portions (204) defining a single double lateral wall being fixed via slotting in the condition where they are folded against one another;

wherein two of said portions (204) that are directly connected to the central portion (202) and are located in positions opposite to the central portion define said corner protections (28),

wherein in each of the two portions two widened ends (205) are positioned at opposite corners of the sheet and have a generic quadrangular profile, each end having a predefined folding line (205') folded in a corresponding angular configuration.

2. The unit according to Claim 1, wherein each tray of said stack that is on top of another immediately underlying tray, rests with its own bottom directly on the products carried by said other underlying tray.

3. The unit according to any one of the preceding claims, comprising a band (6) that is designed to surround a bottom region of said stack of trays (2), and

wherein a bottom region of said covering panel (4) is inserted between said trays (2) and said band (6), said covering panel (4) being supported vertically by said band (6).

4. The unit according to Claim 3, wherein said band has portions (62) projecting downwards that engage corresponding seats provided in said pallet (1).

5. The unit according to Claim 3 or Claim 4, wherein said band (6) is constituted by at least one folded sheet or panel.

6. The unit according to Claim 1, wherein said wall portions are bent in the form of an L to assume a corner configuration.

Patentansprüche

1. Transporteinheit (10) für Produkte (P), insbesondere Lebensmittelprodukte, aufweisend:

- eine Palette (1) oder ähnliche Trägerstruktur; und
- eine Reihe von übereinander gestapelten Trägern (2), auf denen die Produkte (P) angeordnet sind und die durch die Palette (1) getragen sind, wobei
- die Träger durch Einsätze (2) gebildet sind,

welche die Produkte (P) enthalten und übereinander gestapelt sind, wobei die Einsätze jeweils aufweisen:

einen Boden (22), auf dem die Produkte ruhen, und Seitenwände (24), die den Boden (22) umgeben und eine geringe Höhe in Bezug auf die Produkte (P) aufweisen, so dass ein überwiegender Teil der Produkte (P) sichtbar ist; und
- die Einheit (10) wenigstens ein Abdeckpanel (4) aufweist, das wenigstens eine Seite des Stapels von Einsätzen (2) abdeckt und stattdessen wenigstens eine Seite (A1) zur Präsentation der Produkte frei lässt;

wobei die Einheit **dadurch gekennzeichnet ist, dass** die Einsätze (2) jeweils mit Eckschutzvorrichtungen (28) zumindest an der Seite (A1) zur Präsentation der Produkte vorgesehen sind,

wobei die Schutzvorrichtungen (28) der Einsätze (2) durch Wandabschnitte von zwei der Seitenwände (24) gebildet sind, die eine größere Höhe aufweisen und an den gegenüberliegenden Enden der jeweiligen Wand erhalten sind, und wobei

die Wandabschnitte sich über und unter dem Boden (22) des jeweiligen Einsatzes erstrecken, so dass diese einen Schutz sowohl für die von dem jeweiligen Einsatz getragenen Produkte als auch für die von dem darunter liegenden Einsatz getragenen Produkte bilden,

wobei jeder Einsatz aus einem einzigen gefalteten Bogen besteht,

wobei der Bogen einen zentralen Abschnitt (202) aufweist, der dazu bestimmt ist, den Boden (22) des Einsatzes zu definieren, und wenigstens zwei Abschnitte (204), die in Bezug zueinander gefaltet sind, mit jeder Seite des zentralen Abschnitts (202) verbunden sind, um doppelte Seitenwände (24) zu definieren, wobei die beiden Abschnitte (204) eine einzige doppelte Seitenwand definieren, die durch Schlitze in dem Zustand befestigt sind, in dem diese gegeneinander gefaltet sind;

wobei zwei der Abschnitte (204), die direkt mit dem zentralen Abschnitt (202) verbunden sind und in Positionen gegenüber dem zentralen Abschnitt angeordnet sind, die Eckschutzvorrichtungen (28) definieren, wobei

bei jedem der zwei Abschnitte zwei verbreiterte Enden (205) an gegenüberliegenden Ecken des Bogens positioniert sind und ein allgemeines viereckiges Profil aufweisen, wobei jedes Ende eine vordefinierte Faltnie (205') aufweist, die in einer entspre-

chenden winkligen Konfiguration gefaltet ist.

2. Einheit nach Anspruch 1, wobei jeder Einsatz des Stapels, der auf einem anderen, unmittelbar darunter liegenden Einsatz liegt, mit dessen eigenem Boden direkt auf den Produkten aufliegt, die von dem anderen darunter liegenden Einsatz getragen werden.

3. Einheit nach einem der vorhergehenden Ansprüche, aufweisend ein Band (6), das gestaltet ist, einen unteren Bereich des Stapels von Einsätzen (2) zu umgeben, und

wobei ein unterer Bereich des Abdeckpanels (4) zwischen den Einsätzen (2) und dem Band (6) eingefügt ist, wobei das Abdeckpanel (4) von dem Band (6) vertikal getragen ist.

4. Einheit nach Anspruch 3, wobei das Band nach unten vorstehende Abschnitte (62) aufweist, die in entsprechende in der Palette (1) vorgesehene Sitze eingreifen.

5. Einheit nach Anspruch 3 oder Anspruch 4, wobei das Band (6) durch wenigstens einen gefalteten Bogen oder ein gefaltetes Panel gebildet ist.

6. Einheit nach Anspruch 1, wobei die Wandabschnitte in der Form eines L gebogen sind, um eine Eckkonfiguration anzunehmen.

Revendications

1. Unité de transport (10) pour produits (P), en particulier pour produits alimentaires, comprenant :

- une palette (1) ou une structure de support similaire ; et

- une série de supports (2) empilés les uns au-dessus des autres, sur lesquels sont agencés lesdits produits (P) et qui sont portés par ladite palette (1), où :

- lesdits supports sont constitués par des plateaux (2) qui contiennent lesdits produits (P) et sont empilés les uns au-dessus des autres, lesdits plateaux comprenant chacun :

un fond (22) sur lequel lesdits produits reposent, et des parois latérales (24) qui entourent ledit fond (22) et ont une petite hauteur par rapport auxdits produits (P), afin de rendre visible une partie prédominante desdits produits (P) ; et

- ladite unité (10) comprend au moins un panneau de recouvrement (4) qui recouvre au moins un côté de ladite pile de plateaux (2) et laisse

plutôt au moins un côté (A1) exposé pour présenter lesdits produits ;

ladite unité étant **caractérisée en ce que** lesdits plateaux (2) sont chacun prévus avec des protections de coin (28) au moins au niveau dudit côté (A1) pour présenter lesdits produits, dans laquelle lesdites protections (28) desdits plateaux (2) sont constituées par des parties de paroi de deux desdites parois latérales (24) qui ont une plus grande hauteur et sont obtenues au niveau des extrémités opposées de la paroi respective, et où :

lesdites parties de paroi s'étendent sur le dessus de et le dessous du fond (22) du plateau respectif, afin de constituer une protection en ce qui concerne à la fois les produits portés par le plateau respectif et les produits portés par le plateau sous-jacent, dans laquelle chaque plateau est constitué par une seule feuille pliée, dans laquelle ladite feuille comprend une partie centrale (202) conçue pour définir le fond (22) du plateau, et au moins deux parties (204) qui sont pliées l'une par rapport à l'autre, raccordées à chaque côté de la partie centrale (202), pour définir des parois latérales doubles (24), les deux parties (204) définissant une seule paroi latérale double qui est fixée par rainurage dans la condition dans laquelle elles sont pliées l'une contre l'autre ; dans laquelle deux desdites parties (204) qui sont directement raccordées à la partie centrale (202) et sont positionnées dans des positions opposées à la partie centrale définissent lesdites protections de coin (28), dans laquelle dans chacune des deux parties, deux extrémités élargies (205) sont positionnées au niveau des coins opposés de la feuille et ont un profil quadrangulaire générique, chaque extrémité ayant une ligne de pliage (205') prédéfinie pliée dans une configuration angulaire correspondante.

2. Unité selon la revendication 1, dans laquelle chaque plateau de ladite pile qui est sur le dessus d'un autre plateau immédiatement sous-jacent, repose avec son propre fond directement sur les produits portés par ledit autre plateau sous-jacent.
3. Unité selon l'une quelconque des revendications

précédentes, comprenant une bande (6) qui est conçue pour entourer une région de fond de ladite pile de plateaux (2), et

5 dans laquelle une région de fond dudit panneau de recouvrement (4) est insérée entre lesdits plateaux (2) et ladite bande (6), ledit panneau de recouvrement (4) étant supporté verticalement par ladite bande (6).

10 4. Unité selon la revendication 3, dans laquelle ladite bande a des parties (62) faisant saillie vers le bas qui mettent en prise des sièges correspondants prévus dans ladite palette (1).

15 5. Unité selon la revendication 3 ou la revendication 4, dans laquelle ladite bande (6) est constituée par au moins une feuille pliée ou panneau.

20 6. Unité selon la revendication 1, dans laquelle lesdites parties de paroi sont pliées en forme de L pour adopter une configuration de coin.

FIG. 1

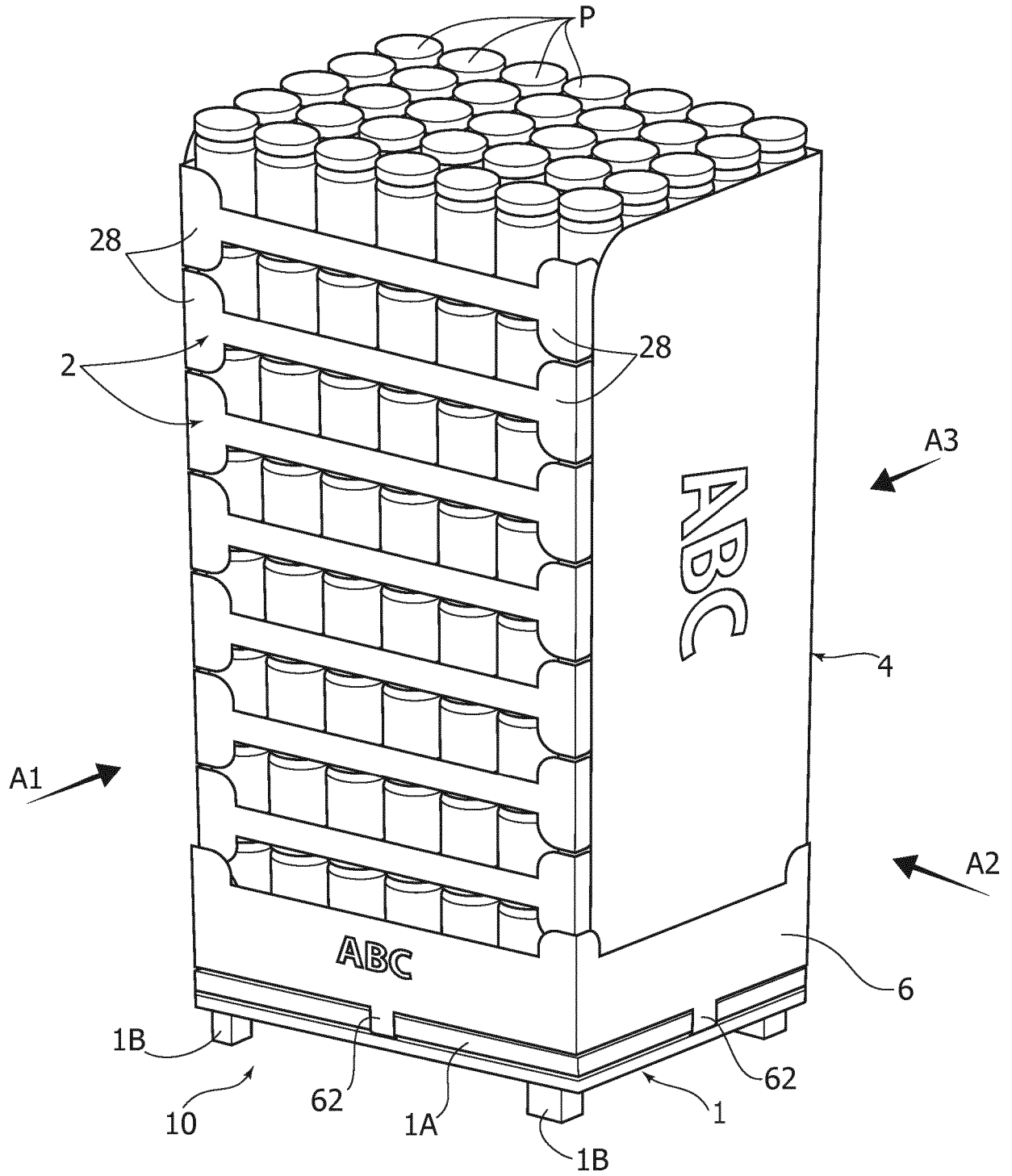

FIG. 2

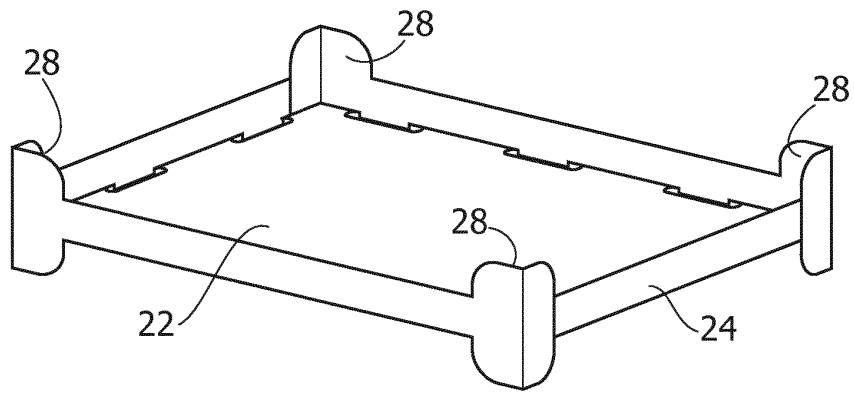
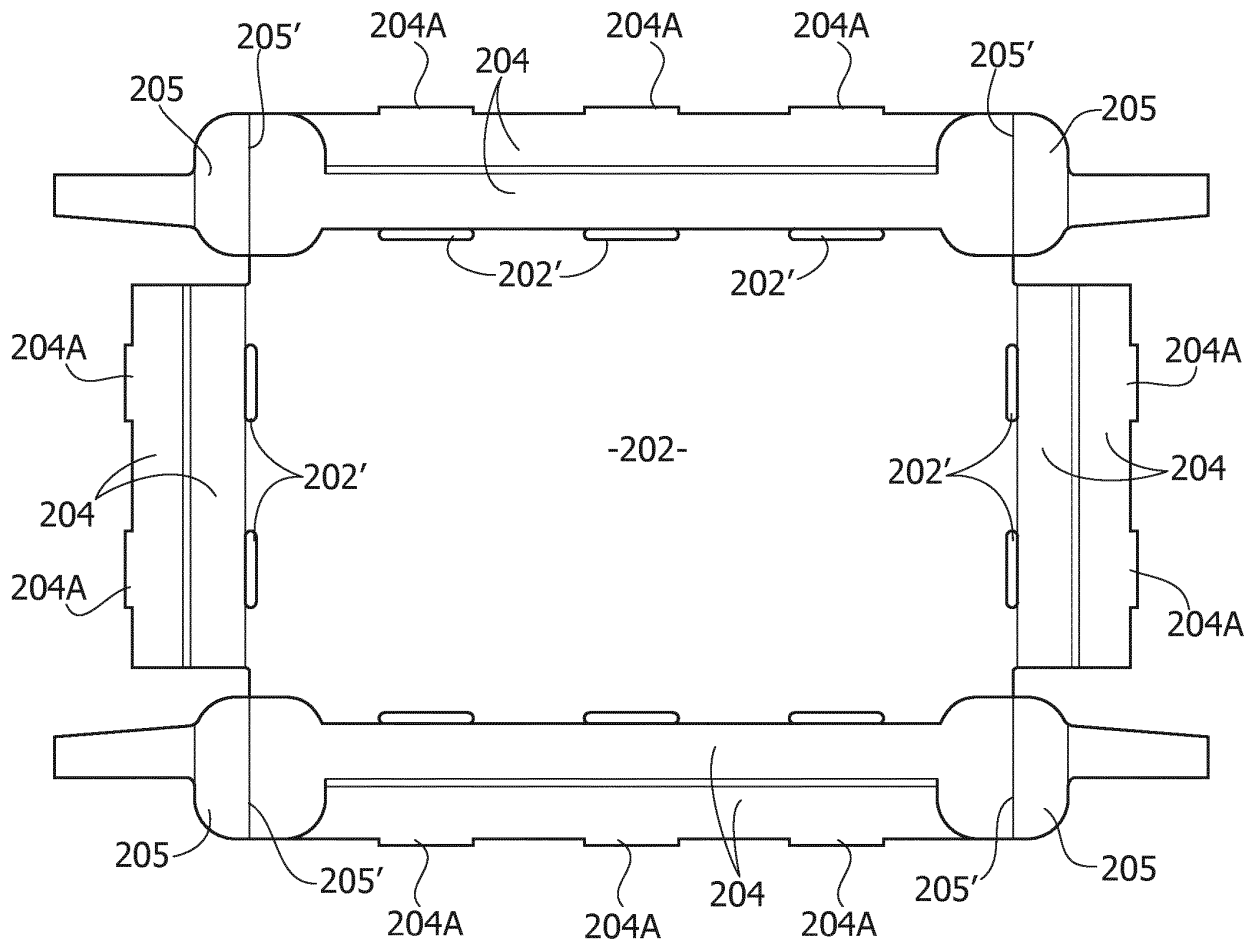

FIG. 3



REFERENCES CITED IN THE DESCRIPTION

This list of references cited by the applicant is for the reader's convenience only. It does not form part of the European patent document. Even though great care has been taken in compiling the references, errors or omissions cannot be excluded and the EPO disclaims all liability in this regard.

Patent documents cited in the description

- US 4567981 A [0003]