

(19)



(11)

EP 3 647 499 B1

(12)

EUROPEAN PATENT SPECIFICATION

(45) Date of publication and mention of the grant of the patent:

03.05.2023 Bulletin 2023/18

(51) International Patent Classification (IPC):

**E02D 29/00^(2006.01) E01F 15/08^(2006.01)
E04B 2/00^(2006.01) E04C 1/00^(2006.01)**

(21) Application number: **19203200.1**

(52) Cooperative Patent Classification (CPC):

**E02B 3/06; E02D 29/025; E02D 29/0266;
E04B 2/32; E04C 1/00; E02B 3/14;
E04B 2002/0217**

(22) Date of filing: **15.10.2019**

(54) **CONCRETE STRUCTURE**

BETONSTRUKTUR

STRUCTURE EN BÉTON

(84) Designated Contracting States:

**AL AT BE BG CH CY CZ DE DK EE ES FI FR GB
GR HR HU IE IS IT LI LT LU LV MC MK MT NL NO
PL PT RO RS SE SI SK SM TR**

(72) Inventor: **Vidal Cavero, Francisco Javier
22430 Graus (Huesca) (ES)**

(30) Priority: **31.10.2018 ES 201831663 U**

(74) Representative: **Ungria López, Javier
Avda. Ramón y Cajal, 78
28043 Madrid (ES)**

(43) Date of publication of application:

06.05.2020 Bulletin 2020/19

(56) References cited:

**WO-A1-01/53612 CA-A1- 2 438 565
DE-A1- 4 131 423 DE-A1-102005 050 456
US-A- 4 993 206**

(73) Proprietor: **Vidal Cavero, Francisco Javier
22430 Graus (Huesca) (ES)**

EP 3 647 499 B1

Note: Within nine months of the publication of the mention of the grant of the European patent in the European Patent Bulletin, any person may give notice to the European Patent Office of opposition to that patent, in accordance with the Implementing Regulations. Notice of opposition shall not be deemed to have been filed until the opposition fee has been paid. (Art. 99(1) European Patent Convention).

Description

OBJECT OF THE INVENTION

[0001] The following invention relates to a concrete structure according to claim 1 formed by at least one concrete block which can be mass concrete, reinforced concrete and/or with fibres which has, as one of its main applications, the construction of retaining walls, although the block can have multiple applications such as a protector element or as a separator element. Due to its configuration it allows perfect connection and stacking, as well as easy handling by means of lifting carts or means based on gripping claws coupled to articulated arms or booms of different devices; all of which in a secure manner.

BACKGROUND OF THE INVENTION

[0002] Retaining walls with stone riprap are a solution for securing earth with a reduced environmental impact and easy landscape integration which are usually implemented based on large blocks of irregular rock, supported and sustained by one another, which are placed in the manner of a puzzle such that as the height of the wall increases, the backfill of the riprap is filled, defined between the natural land and the retaining wall until the desired riprap is shaped.

[0003] This implementation process presents a series of disadvantages, such as that its construction requires the use of heavy machinery as a backhoe, normally caterpillar backhoes and which, by way of an articulated arm provided with a dipper or "claw", the irregular rocks are handled, with the added drawback that if work on asphalt surface is necessary, impairments are caused in the rolling surfaces and disturbances are created affecting road traffic on numerous occasions due to the implementation and/or repair work.

[0004] Similarly, given the irregularity of the stone blocks, on the one hand, the blocks should be selected and their ideal placement should be sought and, equally, as they are placed during the implementation of the retaining wall, they should be stabilised. This requires the help of another operator to align and fit the riprap stones with the resulting risk to the safety of this operator, a risk which increases while the riprap is increasing in height.

[0005] In the unloading and implementation of the stone by means of a caterpillar machine or machine with rubber wheels, the selected stone should be collected, the machine moved to the proximity of the wall and the stone placed in the best position, stabilised by a second operator, if applicable, and said operations, in which all or a large part of the passage surface of the traffic is avoided, in the case where the wall is being produced on a slope of a road, have to be carried out again. This is a serious drawback affecting the traffic.

[0006] Other solutions for these types of work units is the implementation of retaining walls, either in-situ or pre-

fabricated, with the drawback that they are generally slower and more expensive to implement.

[0007] From the state of the art it is known US4993206A which discloses modular construction units that include alternating plateaus and recesses which interfit with one another to form walls without mortar. Drainage grooves are defined in the units and bevels are provided on the perimeter of the front and back to give a brickface appearance to the wall. Special corner units are provided, along with cap units having transverse bores. Retaining walls and fence walls can be obtained employing the units at integral footings defined by the units and drainage passages defined by cooperating drainage grooves.

[0008] In document CA2438565A1 it is proposed a retaining wall block for use to construct a wall. This block has a front surface, a rear surface and a pair of opposite side surfaces defining four vertical edges. It also has a top surface and a bottom surface. Each of the side surfaces is V-shaped and projects outwardly when seen in top or bottom plan view, thereby giving a general truncated diamond-shaped to the top and bottom surfaces of the block. Each of the opposite side surfaces is provided with two integral clippable wings. Each clippable wing projects outwardly from the corresponding side surface so as to extend laterally at least as far away as the corresponding side surface. In use, the wings may be kept or cut depending on the shape selected for the wall to be erected.

[0009] Document DE102005050456A1 relates to a support wall inclined towards a backfill of the soil, made of individual shaped stones arranged in layers one above the other. The stones of adjacent layers each engage with one another in a form-fitting manner in the region of the upper sides and lower sides of the shaped blocks. According to the invention, the top sides and bottom sides are designed in such a way that individual layers are transverse to an imaginary longitudinal axis of the supporting wall and can be moved in the corresponding direction.

[0010] In DE4131423A1 it is disclosed a moulded block with recesses and a kit comprising a joiner with at least one truncated wedge-shaped component with a correspondingly-shaped recess. This permits laying especially superimposed moulded blocks at angles. It is thus possible to build curved retaining walls.

[0011] WO0153612A1 describes a moulded brick made of concrete. Said brick is especially used to produce a supporting wall which is inclined in relation to the normal against an earth backing. The invention also relates to a method for producing said moulded brick and a mould which can be used during the implementation of said method. The upper and lower sides of the moulded bricks are provided with at least two respective bearing surfaces which are progressively offset in relation to each other and run parallel to each other. Said bearing surfaces engage with the bearing surfaces in relation to each other and run parallel to each other and engage with the

bearing surfaces of a neighbouring moulded brick.

DESCRIPTION OF THE INVENTION

[0012] A concrete structure is described in this specification which may or may not be reinforced and/or with fibres.

[0013] The concrete structure according to claim 1 comprises at least one concrete block with a parallelepipedic configuration that includes two opposing bases, two first opposing lateral faces and two second opposing lateral faces.

[0014] One of the bases and one of the first lateral faces of the block which is contiguous to said base include at least two parallel recesses with a symmetric distribution with respect to an imaginary central plane parallel to the two second opposing lateral faces of the block that do not include said recesses; wherein the recesses comprise first sections included in the respective base and second sections included in the respective first lateral face. The sections of the recesses come together coinciding with a common edge of the block in which the base and the first lateral face that include said recesses merge.

[0015] The block includes inlets located at the ends of the first lateral face which is opposed to the first lateral face which includes the second sections of the recesses. The block comprises inlets with blind holes located in its frontal face which delimits the depth of the inlets.

[0016] In one embodiment of the invention, the recesses of the block are delimited by a bottom and two lateral faces converging towards said bottom such that this described configuration facilitates the removal of the block during its manufacture.

[0017] The two inlets of the block are located at the same distance, taking as a reference one of the bases of said block.

[0018] In one particular embodiment of the invention, the two inlets of the block are located at the same centred distance, taking as a reference the two bases of said block.

[0019] In one embodiment of the invention, the reinforced concrete block has dimensions of 2 m x 1 m x 0.5 m; wherein the first lateral faces have greater dimensions than the second lateral faces and wherein the bases have greater dimensions than the first and second lateral faces. With the described dimensions, the concrete block has a weight of around 2200 kg.

[0020] In one embodiment of the invention, the reinforced concrete structure comprises at least one horizontal alignment of blocks connected together which are in contact through pairs of their second opposing lateral faces which are parallel to the imaginary central plane, wherein each pair of adjacent blocks, if desired, can be joined by means of an anchoring device.

[0021] In another embodiment of the invention, a reinforced concrete structure comprising at least two horizontal alignments of blocks stacked in an orderly manner on top of one another staggered with or without setback

can be configured to obtain the gradient or gradients desired.

[0022] The anchoring device comprises threaded elements, a plate with through holes and nuts. The threaded elements are fixed to the block by means of solutions involving a chemical stud, resins, anchoring bolts etc., being inserted into the lateral blind holes of the blocks.

[0023] The plate is housed in a hollow formed by each pair of adjacent inlets of the blocks and the nuts thread in end portions of the threaded elements. In turn, one part of the end portions of the threaded elements is introduced in the through holes of the plate such that, once the anchoring device is installed, the nuts form a stop on the plate and are housed inside the hollow formed by each pair of adjacent inlets.

[0024] Each concrete block in its application will settle in a horizontal plane on its base or lateral face equipped with the pair of recesses, the block being able to adopt a horizontal laying down position or a vertical position such that the face or contiguous base pair thereof also equipped with recesses remains in the vertical position, the pair of recesses in the manner of a channel facilitating the drainage of the water.

[0025] When the concrete blocks are connected in the horizontal position (laying down or resting), settled on their corresponding base equipped with the pair of parallel recesses, the respective adjacent inlets of the connected concrete blocks remain connected and flush, joined together by means of the anchoring devices, wherein each one of the plates fits in the hollow defined by each pair of adjacent inlets.

[0026] In this way, in the configuration of a retaining wall with the concrete blocks settled on their respective bases equipped with recesses parallel and connected to one another, the stacking of the concrete blocks in a staggered manner, as has been previously referred to, is permitted, allowing the joining together of the different concrete blocks connected according to the different rows in horizontal alignments, obtaining a wall with significant strength.

[0027] Similarly, when the application of the invention is for a configuration of a separation or protection barrier, the concrete blocks settle on a horizontal floor plane on the lateral face provided with the pairs of parallel recesses, while the lateral pair face of each block opposed to the lateral face with the parallel recesses, said lateral pair face is arranged in a free upper horizontal plane that includes the adjacent inlets, to be able to fix the blocks by means of the corresponding anchoring devices.

[0028] Thus, as indicated, in a preferred embodiment of the invention, the pair of parallel recesses located in a base and in a contiguous lateral face of the concrete block are implemented in a symmetrical position with respect to the central transversal plane of the concrete block as previously referred to such. By way of said recesses, the handling of the block is facilitated by means of the pair of claws with which the conventional lifting carts or equivalent means are equipped.

[0029] In addition, given that the reinforced concrete block has preferred measures of 2 m × 1 m × 0.5 m and has a weight of approximately 2200 kg, the manufacture of each one of them comprises approximately 1 m³ of concrete, the quantity of concrete material required for shaping the retaining walls to be implemented can be very easily calculated.

[0030] The described concrete block, as indicated, has as an essential application in accordance with its settling face or settling base equipped with the pair of parallel recesses, the implementation of retaining walls or as a separator and protector element, mainly in the improvements or reshaping of different traffic routes, and, similarly, has other different applications such as a delimiter element or closure element and protection of streets or other spaces.

[0031] In order to complement the description that will be given below and with the aim of aiding a better understanding of the features of the invention, the present specification is accompanied by a set of plans, in the figures of which the most characteristic details of the invention are represented in an illustrative and non-limiting manner.

BRIEF DESCRIPTION OF THE FIGURES

[0032]

Figure 1 shows an isometric perspective view of a concrete structure according to claim 1 object of the invention. In this Figure 1, the concrete structure is a unit formed by a concrete block with a parallelepipedic geometric configuration that includes two bases and four lateral walls.

Figure 2 shows a front elevation view of the block of Figure 1.

Figure 3 shows an upper plan view of the block of Figure 1.

Figure 4 shows a lower plan view of the block of Figure 1.

Figure 5 shows a left lateral profile view of the block of Figure 1.

Figure 6 shows a right lateral profile view of the block of Figure 1.

Figure 7 shows another rear elevation view of the block of Figure 1.

Figure 8 shows a perspective view of the concrete structure formed by a pair of concrete blocks joined by means of an anchoring device. It has a horizontal arrangement (resting or laying down) wherein the blocks are supported by one of their bases.

Figure 9 shows a perspective view of a concrete block with a vertical arrangement, wherein the block is supported on one of the lateral faces thereof such that on one of the lateral faces thereof in vertical arrangement, the placement of double T-shaped profiles is permitted which fit into recesses of the block to increase the ability to resist the forces to

which it may be subjected in this position according to the different circumstances.

Figure 10 shows a frontal elevation view of the reinforced concrete structure formed by a pair of connected blocks with a vertical arrangement according to the previous figure and which are joined by means of an anchoring device.

Figure 11 shows a plan view of the reinforced concrete structure formed by a pair of connected blocks with a vertical arrangement according to what is shown in the previous figure.

Figure 12 shows an elevation view of a pair of concrete blocks with two different finishes: a first finished in retaining rock and a second finished in irregular mountain stone.

Figure 13 shows a frontal view of the reinforced concrete structure wherein a stack, an arrangement and a placement of blocks with a staggered distribution are highlighted.

DESCRIPTION OF A PREFERRED EMBODIMENT

[0033] In view of the mentioned figures and according to the adopted numbering, the concrete structure according to claim 1, reinforced or not, comprises at least one reinforced concrete block 1 which has a general parallelepipedic shape that includes two opposing bases 1a, 1b, two larger first opposing lateral faces 1c, 1d; and two smaller second opposing lateral faces 1e, 1f; wherein the two bases 1a, 1b have greater dimensions than the four lateral faces 1c, 1d, 1e, 1f; and wherein in one embodiment of the invention the concrete block 1 is supported in a horizontal position on a support surface (foundation, sill, prepared natural terrain, etc.) by means of one of the bases 1a; without discarding the support on any of the four lateral faces 1c, 1d, 1e, 1f.

[0034] The base 1a and the first contiguous lateral face 1d include a pair of recesses 2, 3 such that according to the view of Figure 1, said pair of recesses 2 and 3 are located in their lower level, corresponding to the base 1a, and in their rear frontal level, corresponding to the first lateral face 1d.

[0035] The recesses 2, 3 comprise first sections located on the base 1a and second sections located on the first lateral face 1d; wherein the first and second sections merge coinciding with a common edge of the base 1a and the first lateral face 1d.

[0036] Said recesses 2, 3 are located with a symmetric distribution with respect to an imaginary central plane 10 which is parallel to the second lateral faces 1e, 1f of the block 1.

[0037] The concrete block 1 includes a pair of inlets 4, 5 located in end areas of the first lateral face 1c which is opposed to the other first lateral pair face 1d.

[0038] Said inlets 4, 5 interrupt the continuity of frontal edges in which the second lateral faces 1e, 1f and the first lateral face 1c, which is opposed to the first lateral face 1d that includes the second sections of the pair of

recesses 2, 3, merge.

[0039] In a preferred embodiment, the inlets 4, 5 are located in a central part, taking as a reference the thickness of the block 1 when it is supported on its base 1a.

[0040] In one embodiment of the invention, on frontal faces of the inlets 4, 5, blind holes are included; preferably a blind hole in each frontal face of each inlet 4, 5.

[0041] In this way, the pair of parallel recesses 2 and 3 are formed at a distance which allows the positioning of the claws of a lifting cart or similar element, with the aim of allowing the handling thereof by means of said claws in a simple, reliable manner with complete security, during its collection and its positioning when creating a retaining wall or similar by means of various, reinforced or not, concrete blocks 1.

[0042] In addition, in the configuration of the retaining walls, the concrete blocks 1 are connected and placed until the desired height is reached, such that during their positioning, the adjacent inlets 4 and 5 of two consecutive blocks 1 are connected and flush with one another, as it is observed for example in Figure 8; wherein said blocks 1 are in contact with one another by way of their smaller second lateral faces 1e, 1f.

[0043] During the stacking of the concrete blocks 1, the same are arranged with a staggered distribution (Figure 13), defining by means of the pairs of recesses 2 and 3, passage and outlet means of water so that it can be displaced and accumulated in the riprap, substantially reducing the thrusts and pressures on the riprap of the retaining wall formed by means of these concrete blocks.

[0044] In addition, with the aim of obtaining rigidity of the retaining wall, the concrete blocks 1 connected to one another can be joined together. To this end, in the corresponding blind holes located at the frontal faces of the adjacent inlets 4 and 5 of pairs of consecutive blocks, threaded elements 6 (bolts or threaded rods) are inserted and joined together by means of plates 7 with through holes and nuts 8; wherein said plates 7 are housed in hollows defined by pairs of adjacent inlets 4 and 5.

[0045] In this way, in one preferred embodiment, the threaded elements 6 are kept together in the corresponding blind holes by means of studs of chemical material, a resin or equivalent system and in the joining to the plates 7 which are fixed by means of nuts 8 coupled to end portions of the threaded elements 6 which pass through the through holes of said plates 7, with the possibility of including reinforcements formed by jam nuts not represented in the figures.

[0046] In addition, the retaining walls can be finished by their laterals in a tiered shape or vertical manner, in which case the horizontal rows or alignments of concrete blocks 1 are finished (those rows, as required) by half concrete block to obtain the desired finish at their end laterals.

[0047] Similarly, the concrete blocks 1 can have a smooth finish on all the faces or bases thereof, or can have, on their visible faces or bases, different finishes which facilitate their integration into the surroundings, as

is represented in Figure 12 such that the visible face of the set of the retaining wall has the desired finish.

[0048] Likewise, some concrete blocks 1, in addition to the visible lateral faces or bases thereof with different finishes, are also topped with identical finish, on one of the laterals, allowing their positioning in one or another of the end sides of the retaining wall, obtaining a wall lateral finish identical to its visible frontal face.

[0049] In the same way, with the aim of obtaining unity of the assembly, if necessary, this can be achieved in the wall by means of blocks with identical finish on their visible frontal face and their closure lateral face.

[0050] The concrete blocks 1 can be used for multiple uses and thus reference can be made to its use as a means of signalling and/or provisional protection in the implementation, repair, modification or regulation in traffic routes, streets, squares, etc.

[0051] In these cases, the concrete blocks 1 will settle on their larger first lateral face 1d that includes the recesses 2, 3 adopting a vertical positioning of the blocks 1 such that, in relation to the first sections of the recesses 2 and 3 of the base 1a arranged in a vertical position, anchoring means will be placed, such as double T-shaped profiles 9 by means of which the concrete blocks 1 are secured from possible impacts, improving their action as a protection element; all of which as shown in Figures 10 and 11. Thus, the double T-shaped profiles 9 are located within the first sections of the recesses 2, 3 at the same time as end parts of said double T-shaped profiles 9 are spiked in the ground.

[0052] In this way, the implementation of the reinforced concrete block 1 as described provides very different advantages, and thus, firstly the materialisation of the blocks 1 can be carried out by means of using the concrete residue from mixer trucks left over from constructions and which, conventionally, is discarded, which represents economic savings and an environmental benefit.

[0053] Secondly, an important advantage is provided as a result of the structure of the blocks 1 themselves, and thus, on the one hand, the handling, transport and the implementation of the retaining wall itself is facilitated since the handling of the blocks can be carried out by means of lifting carts or means based on gripping claws coupled to articulated arms or booms of different devices in a secure manner.

[0054] In addition, it is highlighted that in terms of the transportation of the blocks 1, the capacity of the transport means is optimised, since the blocks can be connected and stacked, encompassing the entire loading space and in the execution of the unloading operations and obtaining the retaining wall, since they can be carried out, as indicated, by means of lifting carts or boom trucks, without the need to use additional machinery with caterpillar roller means. Impairments in the road are avoided and it can be carried out faster and with less intervention in the normal road traffic.

[0055] Going further into the topic of unloading and implementation of the retaining wall, in the case where work

is being carried out on a road, it is sufficient for a boom truck to be placed behind the blocks transport vehicle and to collect said blocks and place them during the implementation of the wall, without the need to have to stabilise them, allowing one of the traffic lanes to remain free, having a considerably lower impact on the road traffic and allowing to carry out the operation in less time.

[0056] Definitively, the main advantage of the invention is the security obtained by the structure of the block 1 since it allows its stacking when forming the corresponding retaining wall in a completely stable manner without the need to have an operator stabilise the blocks 1 as the wall is being constructed, with the risk that would be involved therewith. With the block 1 of the invention, significant optimisation is achieved in the time and the cost of the operations of transport, unloading and implementation of the blocks 1 to construct the wall.

[0057] It should be noted that although the blocks comprise a parallelepipedic configuration, they can also exhibit other prismatic configurations, such as for example a cubic configuration in which the blocks have the eight faces identical.

Claims

1. **A concrete structure**, comprising a plurality of concrete blocks (1) with a parallelepipedic configuration that include two opposing bases (1a, 1b), two first opposing lateral faces (1c, 1d) and two second opposing lateral faces (1e, 1f); and one of the bases and one of the first lateral faces of the block (1), contiguous to said base, include at least two parallel recesses (2, 3) with a symmetrical distribution with respect to an imaginary central plane (10) parallel to the two second opposing lateral faces of the block (1) that do not include said recesses (2, 3); wherein the recesses (2, 3) comprise first sections included in the respective base and second sections included in the respective first lateral face; and wherein said sections of the recesses (2, 3) come together coinciding with a common edge of the block (1) in which the base and the first lateral face that include said recesses (2, 3) merge;

- wherein the blocks (1) comprise inlets (4, 5) located in end areas of the first lateral face which is opposed to the first lateral face that includes the second sections of the recesses (2, 3), the concrete structure is **characterized in that** the inlets (4, 5) comprising blind holes in frontal faces delimiting the depth of the inlets (4, 5), and
- the inlets (4, 5) comprise at least an anchoring device with threaded elements (6), a plate (7) with through holes and nuts (8); and
- the inlets (4, 5) of the blocks form a hollow for receiving the anchoring device so the plate (7) is housed in said hollow and the nuts (8) thread

in end portions of the threaded elements (6) and one part of the end portions of the threaded elements (6) is introduced in the through holes of the plate (7) such that, once the anchoring device is installed, the nuts (8) form a stop on the plate (7) and are housed inside the hollow.

2. **The concrete structure** according to claim 1, **characterised in that** the recesses (2, 3) of the block (1) are delimited by a bottom and two lateral faces converging towards said bottom.

3. **The concrete structure** according to any one of the preceding claims, **characterised in that** the two inlets (4, 5) of the block (1) are located at the same distance, taking as a reference one of the bases (1a, 1b) of said block (1).

4. **The concrete structure** according to any one of claims 1 to 3, **characterised in that** the two inlets (4, 5) of the block (1) are located at the same centred distance, taking as a reference the two bases (1a, 1b) of said block (1).

5. **The concrete structure** according to any one of the preceding claims, **characterised in that** the concrete block (1) has dimensions of $2\text{ m} \times 1\text{ m} \times 0.5\text{ m}$; wherein the first lateral faces (1c, 1d) have greater dimensions than the second lateral faces (1e, 1f) and wherein the bases (1a, 1b) have greater dimensions than the first and second lateral faces (1c, 1d, 1e, 1f).

6. **The concrete structure** according to claim 1, **characterised in that** it comprises at least one horizontal alignment of blocks (1), connected to one another, which are in contact through pairs of the first opposed lateral faces thereof that are parallel to the imaginary central plane (10); wherein each block comprises blind holes in the frontal faces of the inlets (4, 5) and each pair of adjacent blocks (1) is joined by means of an anchoring device.

7. **The concrete structure** according to claim 6, **characterised in that** it comprises at least two horizontal alignments of blocks (1) one on top of another; wherein the blocks (1) are positioned in a staggered manner.

8. **The concrete structure** according to any one of claims 6 or 7, **characterised in that** the anchoring device comprises threaded elements (6), a plate (7) with through holes and nuts (8); wherein the threaded elements (6) are fixed to studs inserted into the blind holes, the plate (7) is housed in the hollow formed by each pair of adjacent inlets (4, 5) of the blocks (1) and the nuts (8) are threaded in end portions of the threaded elements (6); and wherein parts of the end portions of the threaded elements (6) are

introduced in the through holes of the plate (7) on which the nuts (8) sit.

9. **The concrete structure** according to claim 5, **characterised in that** the concrete block (1), which has measures of 2 m × 1 m × 0.5 m, has a weight of around 2200 kg.
10. **The concrete structure** according to any one of the preceding claims, **characterised in that** the concrete blocks include an internal reinforcement.

Patentansprüche

1. Betonkonstruktion, die eine Vielzahl von Betonblöcken (1) mit einer Quaderform umfasst, die zwei einander gegenüberliegende Grundflächen (1a, 1b), zwei erste einander gegenüberliegende Seitenflächen (1c, 1d) sowie zwei zweite einander gegenüberliegende Seitenflächen (1e, 1f) aufweist; wobei eine der Grundflächen und eine der an die Grundfläche angrenzenden ersten Seitenflächen des Blocks (1) wenigstens zwei parallele Aussparungen (2, 3) mit einer symmetrischen Verteilung in Bezug auf eine imaginäre Mittelebene (10) parallel zu den zwei zweiten einander gegenüberliegenden Seitenflächen des Blocks (1) enthalten, die die Aussparungen (2, 3) nicht enthalten; wobei die Aussparungen (2, 3) erste Abschnitte, die in der jeweiligen Grundfläche enthalten sind, sowie zweite Abschnitte umfassen, die in der jeweiligen ersten Seitenfläche enthalten sind; und wobei die Abschnitte der Aussparungen (2, 3) in Deckung mit einer gemeinsamen Kante des Blocks (1) aufeinandertreffen, an der die Grundfläche und die erste Seitenfläche, die die Aussparungen (2, 3) enthalten, ineinander übergehen;
- wobei die Blöcke (1) Einlässe (4, 5) umfassen, die sich in Endbereichen der ersten Seitenfläche befinden, die der ersten Seitenfläche gegenüberliegt, die die zweiten Abschnitte der Aussparungen (2, 3) enthält, wobei die Betonkonstruktion **dadurch gekennzeichnet ist, dass** die Einlässe (4, 5) Grundlöcher in Stirnflächen umfassen, die die Tiefe der Einlässe (4, 5) begrenzen, und
 - die Einlässe (4, 5) wenigstens eine Verankerungsvorrichtung mit Gewindeelementen (6), eine Platte (7) mit Durchgangslöchern sowie Muttern (8) umfassen; und
 - die Einlässe (4, 5) der Blöcke einen Hohlraum zum Aufnehmen der Verankerungsvorrichtung bilden, so dass die Platte (7) in dem Hohlraum aufgenommen ist und die Muttern (8) in Endabschnitte der Gewindeelemente (6) eingeschraubt werden und ein Teil der Endabschnitte der Gewindeelemente (6) in die Durchgangslö-

cher der Platte (7) so eingeführt wird, dass, wenn die Verankerungsvorrichtung installiert ist, die Muttern (8) einen Anschlag an der Platte (7) bilden und im Inneren des Hohlrums aufgenommen sind.

2. Betonkonstruktion nach Anspruch 1, **dadurch gekennzeichnet, dass** die Aussparungen (2, 3) des Blocks (1) durch einen Boden und zwei zu diesem Boden hin zusammenlaufende Seitenflächen begrenzt sind.
3. Betonkonstruktion nach einem der vorangehenden Ansprüche, **dadurch gekennzeichnet, dass** die zwei Einlässe (4, 5) des Blocks (1) in dem gleichen Abstand angeordnet sind, wobei eine der Grundflächen (1a, 1b) des Blocks (1) als eine Bezugsfläche dient.
4. Betonkonstruktion nach einem der Ansprüche 1 bis 3, **dadurch gekennzeichnet, dass** die zwei Einlässe (4, 5) des Blocks (1) in dem gleichen mittigen Abstand angeordnet sind, wobei die beiden Grundflächen (1a, 1b) des Blocks (1) als eine Bezugsfläche dienen.
5. Betonkonstruktion nach einem der vorangehenden Ansprüche, **dadurch gekennzeichnet, dass** der Betonblock (1) Abmessungen von 2 m × 1 m × 0,5 m hat; wobei die ersten Seitenflächen (1c, 1d) größere Abmessungen haben als die zweiten Seitenflächen (1e, 1f) und die Grundflächen (1a, 1b) größere Abmessungen haben als die ersten und zweiten Seitenflächen (1c, 1d, 1e, 1f).
6. Betonkonstruktion nach Anspruch 1, **dadurch gekennzeichnet, dass** sie wenigstens eine horizontale Anordnung von Blöcken (1) umfasst, die miteinander verbunden sind und über Paare der ersten gegenüberliegenden Seitenflächen derselben, die parallel zu der imaginären Mittelebene (10) sind, in Kontakt sind, wobei jeder Block Grundlöcher in den Stirnflächen der Einlässe (4, 5) umfasst und jedes Paar benachbarter Blöcke (1) mittels einer Verankerungsvorrichtung verbunden ist.
7. Betonkonstruktion nach Anspruch 6, **dadurch gekennzeichnet, dass** sie wenigstens zwei horizontale Anordnungen von Blöcken (1) übereinander umfasst, wobei die Blöcke (1) versetzt angeordnet sind.
8. Betonkonstruktion nach einem der Ansprüche 6 oder 7, **dadurch gekennzeichnet, dass** die Verankerungsvorrichtung Gewindeelemente (6), eine Platte (7) mit Durchgangslöchern sowie Muttern (8) umfasst; wobei die Gewindeelemente (6) an Bolzen befestigt sind, die in die Grundlöcher eingeführt sind, die Platte (7) in dem Hohlraum aufgenommen ist,

der von jedem Paar benachbarter Einlässe (4, 5) der Blöcke (1) gebildet wird, und die Muttern (8) in Endabschnitte der Gewindeelemente (6) eingeschraubt sind; und wobei Teile der Endabschnitte der Gewindeelemente (6) in die Durchgangslöcher der Platte (7) eingeführt sind, auf denen die Muttern (8) sitzen.

9. Betonkonstruktion nach Anspruch 5, **dadurch gekennzeichnet, dass** der Betonblock (1) mit den Maßen $2\text{ m} \times 1\text{ m} \times 0,5\text{ m}$ ein Gewicht von etwa 2200 kg hat.

10. Betonkonstruktion nach einem der vorangehenden Ansprüche, **dadurch gekennzeichnet, dass** die Betonblöcke eine innere Bewehrung aufweisen.

Revendications

1. Structure en béton, comprenant une pluralité de blocs de béton (1) avec une configuration parallélépipédique qui incluent deux bases opposées (1a, 1b), deux premières faces latérales opposées (1c, 1d) et deux secondes faces latérales opposées (1e, 1f); et l'une des bases et l'une des premières faces latérales du bloc (1), contiguë à ladite base, incluent au moins deux évidements parallèles (2, 3) avec une distribution symétrique par rapport à un plan central imaginaire (10) parallèle aux deux secondes faces latérales opposées du bloc (1) qui n'incluent pas lesdits évidements (2, 3); où les évidements (2, 3) comprennent des premières sections incluses dans la base respective et des secondes sections incluses dans la première face latérale respective; et où lesdites sections des évidements (2, 3) se rejoignent en coïncidant avec un bord commun du bloc (1) dans lequel la base et la première face latérale qui incluent lesdits évidements (2, 3) se confondent;

- où les blocs (1) comprennent des entrées (4, 5) situées dans des zones d'extrémité de la première face latérale qui est opposée à la première face latérale qui inclut les secondes sections des évidements (2, 3), la structure en béton est **caractérisée en ce que** les entrées (4, 5) comprenant des trous borgnes dans des faces frontales délimitant la profondeur des entrées (4, 5), et
- les entrées (4, 5) comprennent au moins un dispositif d'ancrage avec des éléments filetés (6), une plaque (7) avec des trous traversants et des écrous (8); et
- les entrées (4, 5) des blocs forment un creux pour recevoir le dispositif d'ancrage, ainsi la plaque (7) est logée dans ledit creux et les écrous (8) se vissent dans des portions d'extrémité des éléments filetés (6) et une partie des portions d'extrémité des éléments filetés (6) est introdui-

te dans les trous traversants de la plaque (7) de sorte qu'une fois que le dispositif d'ancrage est installé, les écrous (8) forment une butée sur la plaque (7) et sont logés à l'intérieur du creux.

2. Structure en béton selon la revendication 1, **caractérisée en ce que** les évidements (2, 3) du bloc (1) sont délimités par un fond et deux faces latérales convergeant vers ledit fond.
3. Structure en béton selon l'une quelconque des revendications précédentes, **caractérisée en ce que** les deux entrées (4, 5) du bloc (1) sont situées à la même distance, en prenant comme référence l'une des bases (1a, 1b) dudit bloc (1).
4. Structure en béton selon l'une quelconque des revendications 1 à 3, **caractérisée en ce que** les deux entrées (4, 5) du bloc (1) sont situées à la même distance centrée, en prenant comme référence les deux bases (1a, 1b) dudit bloc (1).
5. Structure en béton selon l'une quelconque des revendications précédentes, **caractérisée en ce que** le bloc de béton (1) a des dimensions de $2\text{ m} \times 1\text{ m} \times 0,5\text{ m}$; où les premières faces latérales (1c, 1d) ont des dimensions plus grandes que les secondes faces latérales (1e, 1f) et où les bases (1a, 1b) ont des dimensions plus grandes que les premières et les secondes faces latérales (1c, 1d, 1e, 1f).
6. Structure en béton selon la revendication 1, **caractérisée en ce qu'elle** comprend au moins un alignement horizontal de blocs (1), reliés les uns aux autres, qui sont en contact par des paires de leurs premières faces latérales opposées qui sont parallèles au plan central imaginaire (10); où chaque bloc comprend des trous borgnes dans les faces frontales des entrées (4, 5) et chaque paire de blocs (1) adjacents est réunie au moyen d'un dispositif d'ancrage.
7. Structure en béton selon la revendication 6, **caractérisée en ce qu'elle** comprend au moins deux alignements horizontaux de blocs (1) l'un au-dessus de l'autre; où les blocs (1) sont positionnés d'une manière décalée.
8. Structure en béton selon l'une quelconque des revendications 6 ou 7, **caractérisée en ce que** le dispositif d'ancrage comprend des éléments filetés (6), une plaque (7) avec des trous traversants et des écrous (8); où les éléments filetés (6) sont fixés à des goujons insérés dans les trous borgnes, la plaque (7) est logée dans le creux formé par chaque paire d'entrées (4, 5) adjacentes des blocs (1) et les écrous (8) sont vissés dans des portions d'extrémité des éléments filetés (6); et où des parties des por-

tions d'extrémité des éléments filetés (6) sont introduites dans les trous traversants de la plaque (7) sur laquelle reposent les écrous (8).

9. Structure en béton selon la revendication 5, **caractérisée en ce que** le bloc de béton (1), qui a des dimensions de $2\text{ m} \times 1\text{ m} \times 0,5\text{ m}$, a un poids d'environ 2200 kg. 5
10. Structure en béton selon l'une quelconque des revendications précédentes, **caractérisée en ce que** les blocs de béton incluent une armature interne. 10

15

20

25

30

35

40

45

50

55

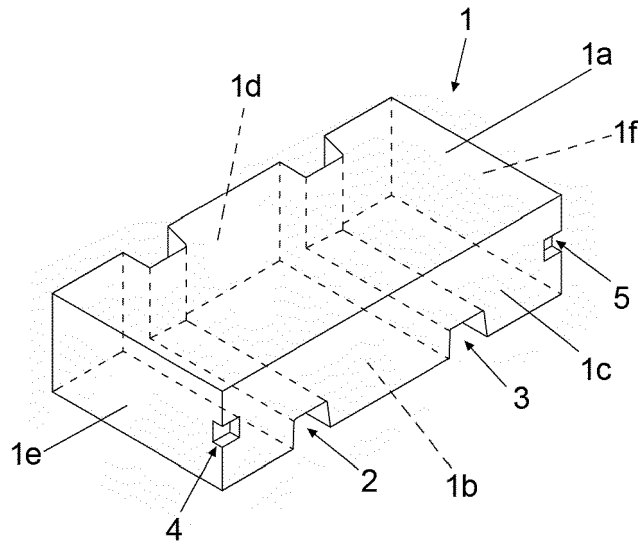

FIG. 1

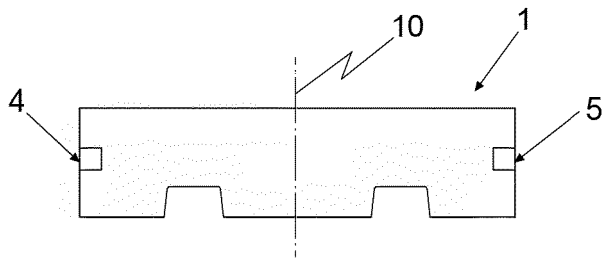

FIG. 2

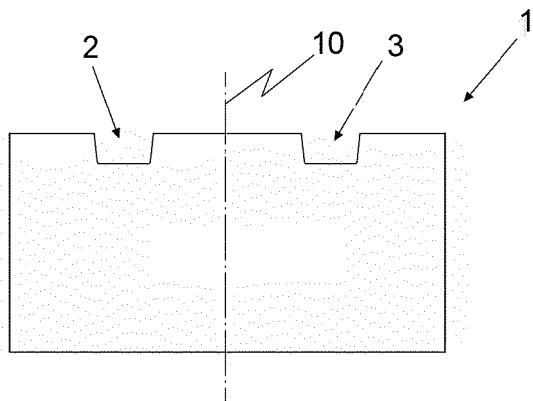

FIG. 3

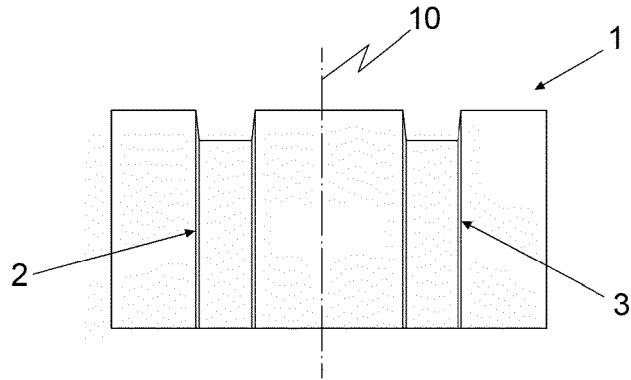

FIG. 4

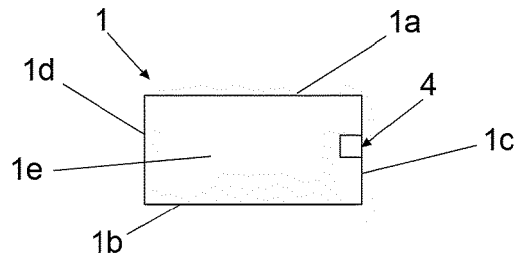

FIG. 5

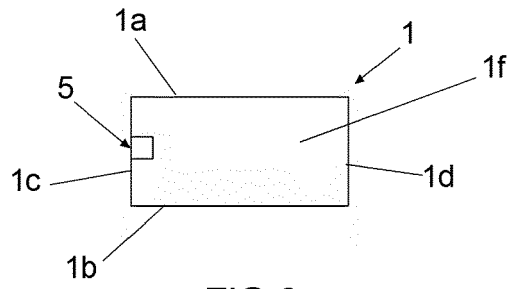

FIG. 6

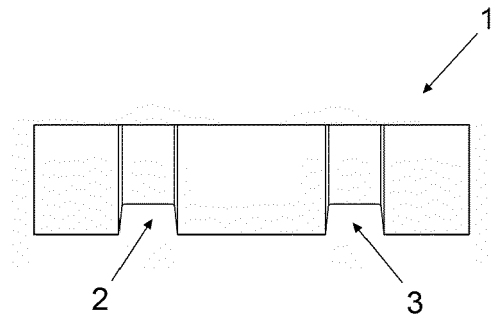

FIG. 7

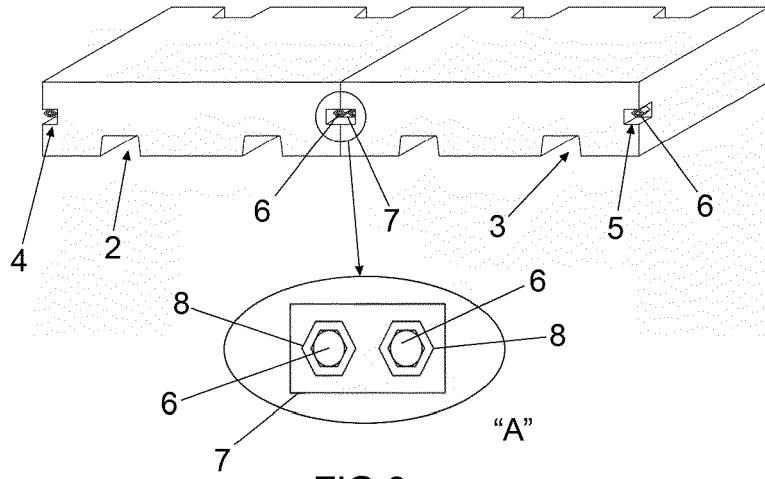

FIG. 8

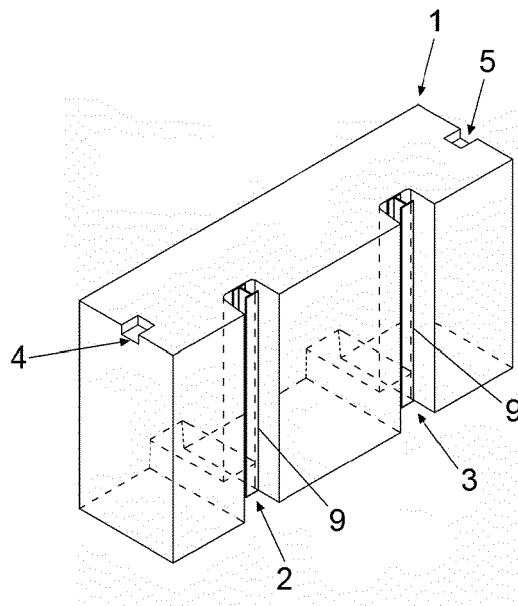

FIG. 9

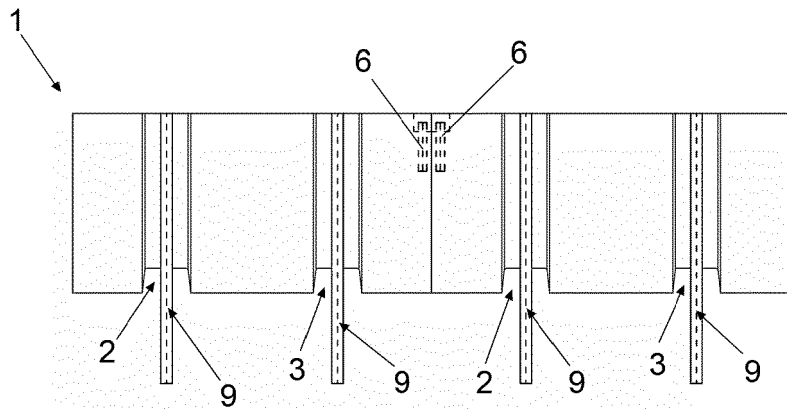

FIG. 10

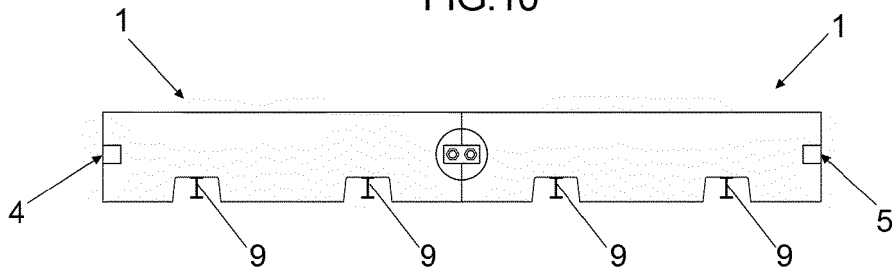

FIG. 11

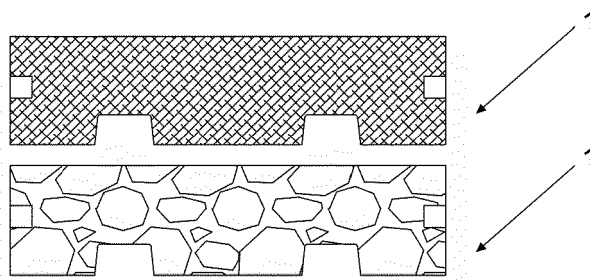

FIG. 12

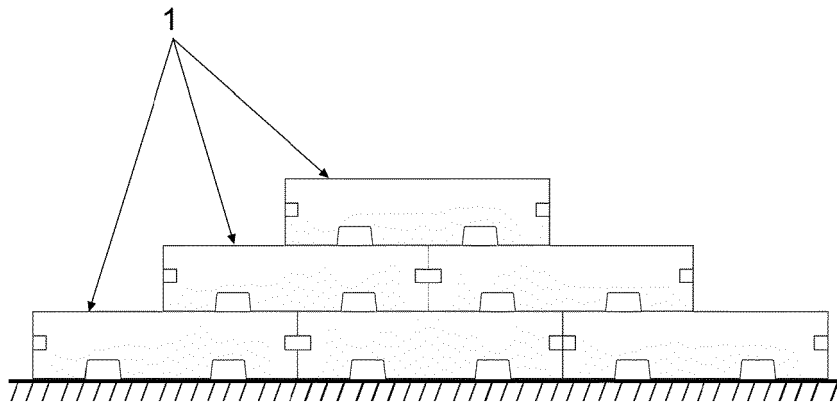

FIG.13

REFERENCES CITED IN THE DESCRIPTION

This list of references cited by the applicant is for the reader's convenience only. It does not form part of the European patent document. Even though great care has been taken in compiling the references, errors or omissions cannot be excluded and the EPO disclaims all liability in this regard.

Patent documents cited in the description

- US 4993206 A [0007]
- CA 2438565 A1 [0008]
- DE 102005050456 A1 [0009]
- DE 4131423 A1 [0010]
- WO 0153612 A1 [0011]