



(12) **EUROPEAN PATENT APPLICATION**

(43) Date of publication:
20.05.2020 Bulletin 2020/21

(51) Int Cl.:
B65D 88/54 (2006.01) B67D 7/06 (2010.01)

(21) Application number: **18207087.0**

(22) Date of filing: **19.11.2018**

(84) Designated Contracting States:
AL AT BE BG CH CY CZ DE DK EE ES FI FR GB GR HR HU IE IS IT LI LT LU LV MC MK MT NL NO PL PT RO RS SE SI SK SM TR
 Designated Extension States:
BA ME
 Designated Validation States:
KH MA MD TN

(71) Applicant: **Water Hammer B.V.**
NL 7541 WH Enschede (NL)
 (72) Inventor: **Beugelink, Wybren Wieger**
7544 RB Enschede (NL)
 (74) Representative: **'t Jong, Bastiaan Jacob**
Inaday Patent B.V.
Hengelosestraat 141
7521 AA Enschede (NL)

(54) **COMBINATION OF A LIQUID TANK, A SUCTION PIPE, A SHUT-OFF VALVE AND A RELIEF VALVE**

(57) Combination of a liquid tank and a suction pipe, wherein the liquid tank comprises an outlet, wherein the outlet comprises a shut-off valve, and where the suction pipe is arranged within the liquid tank, wherein the suction pipe comprises a suction end and a connection end, and

wherein the connection end of the suction pipe is connected to the outlet of the liquid tank, and wherein a relief valve is arranged in the wall of the suction pipe and adjacent to the connection end.

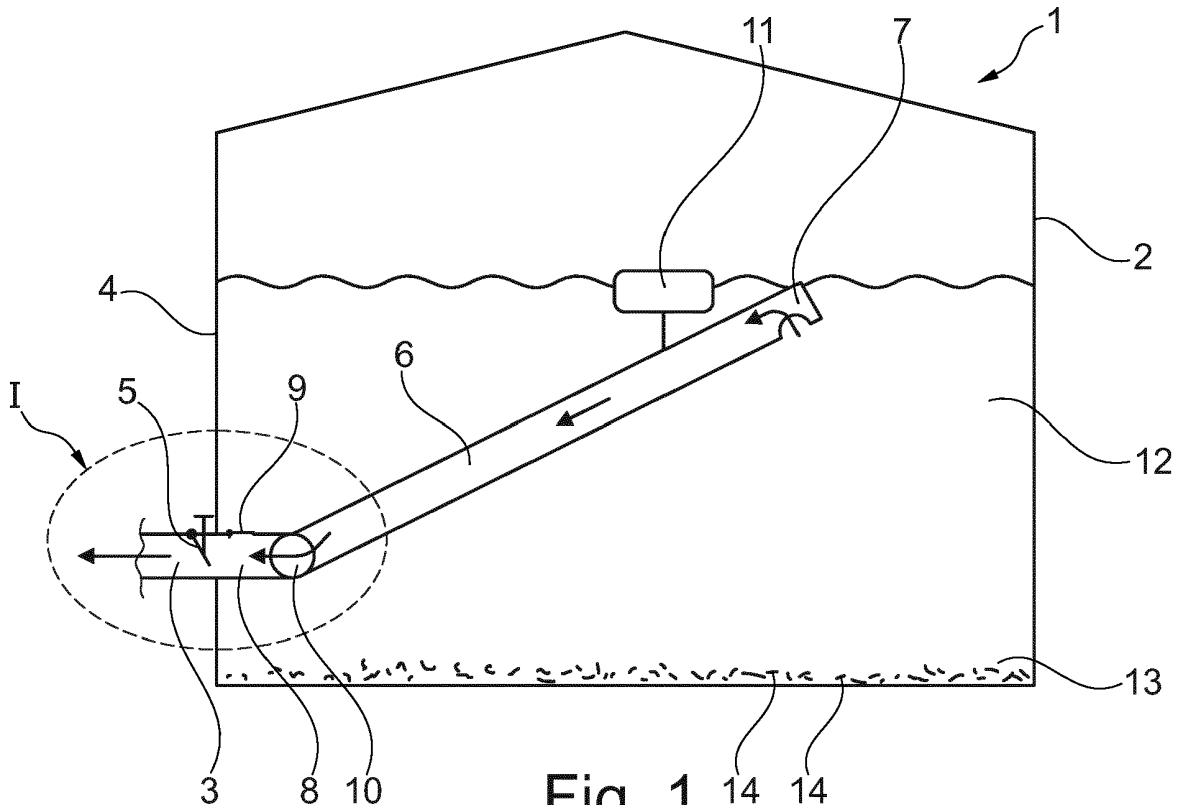

Fig. 1

Description

[0001] The invention relates to a combination of a liquid tank and a suction pipe, wherein the liquid tank comprises an outlet, wherein the outlet comprises a shut-off valve, and where the suction pipe is arranged within the liquid tank, wherein the suction pipe comprises a suction end and a connection end, and wherein the connection end of the suction pipe is connected to the outlet of the liquid tank.

[0002] Such combination is for example known from US3172581.

[0003] It is a common problem with liquid products stored in liquid tanks, to become contaminated with impurities and solids which are heavier than the product. For example in the case of fuel or oil, contamination with water, sludge or colonizing bacteria is often encountered. These impurities, being heavier than the stored liquid, collect around the bottom of the tank.

[0004] In order to withdraw high quality product from the tank, floating suction lines are commonly employed. Instead of draining the tank with an outlet positioned close to the bottom of the tank, where typically the product is found with the most contaminations, the product is withdrawn from the surface of the liquid product. By pivotally connecting a suction pipe to an outlet of a tank, and by attaching a float to the suction end of the pipe, high quality product can be withdrawn close by the surface of the liquid.

[0005] In order to make it easier to keep the suction pipe or hose afloat, the suction pipes or hoses are typically designed for low weight.

[0006] Especially in the case of tanks equipped for storing flammable, or otherwise dangerous, liquids, the outlet conduit of the tank often includes a shut-off valve. In case there is something wrong down the line, the shut-off valve can be closed to prevent further supply or spillage of liquid.

[0007] Sudden closure of a safety- or shut-off valve can cause liquid hammer in the suction pipe or hose. Even though the floating suction pipe is open-ended, the pressure spike, or the pressure dip that follows it, can cause severe damage to the floating suction line. Especially combined with the fact that the suction pipe is optimized for its weight, instead of for its strength, collapse of the pipe due to the effect of the liquid hammer can easily occur.

[0008] Actuation of the shut-off valve in case of an emergency can thus easily cause significant collateral damage. Expensive repairs to the floating suction line as well as potentially prolonged stalling of delivery of fuel can very quickly become costly.

[0009] It is an object of the invention to reduce or even remove the above mentioned disadvantages.

[0010] This object is achieved according to the invention with a combination according to the preamble, which is characterized in that a relief valve is arranged in the wall of the suction pipe and adjacent to the connection

end.

[0011] By arranging a pressure relief valve in the suction pipe, close to the connection end, the pressure spike or dip, occurring due to the sudden stopping of the fluid by closing the shut-off valve, can be relieved by allowing the fluid an auxiliary passage between the inside of the pipe and the tank. The potential damage to the suction pipe within the tank, by the effect of liquid hammer, can thus be prevented. Having the relief valve arranged close to the connection end further ensures that no weight has to be added to the free end of the suction pipe.

[0012] While strengthening of the wall of the suction pipe might help to prevent potential damage too, it is unwanted to add weight to the, potentially floating, part of the suction pipe that extends into the tank.

[0013] There are numerous ways in which such a relief valve can be embodied. Preferably, the valve is quick-acting and its opening corresponds with the closing of the shut-off valve. Both aspects increase the effectiveness of the prevention of pressure buildup inside the suction pipe.

[0014] The relief valve can be a simple flap which closes by the action of fluid flowing past the flap, or a lever on the flap. Alternatively the valve can be spring loaded so that it closes when there is no positive pressure inside the pipe. The valve can also be composed of flexible flaps arranged over openings in the wall of the pipe.

[0015] Because the pipe is a suction pipe, the pressure in the pipe is lower than in the tank during the suction of fluid. This negative pressure exerts a closing force on the valve or flap. Spring action on the flap is thus not strictly necessary, but can be beneficial for other reasons.

[0016] The relief valve can also be arranged such that it opens when a negative relative pressure exists within the suction pipe that exceeds, for example with a factor, the negative pressure difference which normally exists during suction.

[0017] Furthermore, the relief valve can be double-acting, where the valve opens whenever there is a pressure difference exceeding the pressure differences expected during normal operation, regardless of whether the relative pressure is positive or negative.

[0018] In another combination according to the invention, the suction pipe comprises a joint arranged between the opening and the suction end, allowing the suction end to pivot around the joint, relative to the connection end.

[0019] By adding a joint allowing the suction end to pivot relative to the connection end, the level from which the liquid is withdrawn can be chosen more freely than with a fixed suction pipe. The joint can be constructed in a number of ways. For example using a flexible section or a ball-joint in the suction pipe.

[0020] Also according to the invention, is another combination wherein adjacent to the suction end a float is arranged.

[0021] By adding a buoyant object to the free end of the suction pipe or hose, the level from which the fluid is

sucked can be chosen relative to the surface of the fluid. The float can also be the roof, since it is common practice to employ a floating roof with liquid tanks.

[0022] In another preferred combination according to the invention, both the shut-off valve and the relief valve comprise an open position and a closed position, and wherein the positions of both valves are coupled, such that the closed position of the relief valve corresponds with the open position of the shut-off valve and vice versa.

[0023] By coupling the transitions of the shut-off valve and the relief valve, an alternate passage for the liquid, back into the tank, is opened without even necessitating an increase in pressure which is otherwise needed to open a relief valve.

[0024] The coupling between the valves can be achieved mechanically, or using other common means to couple valve action. The function of the two valves can also be combined in a diverter valve, preferably having constant opening even during switchover of valve positions.

[0025] Another preferred combination according to the invention, is a combination where the relief valve is a non-return valve, wherein the flow direction of the non-return valve is directed from the inside towards the outside of the suction pipe.

[0026] The relief valve needs to allow a one-way flow in case the pressure in the suction pipe is higher than outside of the suction pipe, but should block the reverse flow in case the pressure in the pipe is lower. This property is delivered by non-return valves or check-valves. Such one-way valves are available in a wide variety, so that a proper valve can easily be selected for a given application.

[0027] These and other features of the invention will be elucidated in conjunction with the accompanying drawings.

Figure 1 shows a schematic cross-sectional view of a first embodiment of a combination according to the invention.

Figure 2A shows a detail of the embodiment depicted in figure 1, with the shut-off valve in open position and the relief valve in closed position.

Figure 2B shows a detail of the embodiment depicted in figure 1, with the shut-off valve in closed position and the relief valve in open position.

Figure 3 shows a schematic top-view of another embodiment according to the invention, where the shut-off valve and the relief valve are combined in a diverter valve.

Figure 4 shows a schematic top-view of an alternative embodiment according to the invention, where the shut-off valve and the relief valve are combined in a diverter valve placed external to the tank.

[0028] Figure 1 shows a cross-sectional view of a first embodiment of a combination 1 according to the invention. The combination consists of a liquid tank 2 with an

outlet 3 arranged in the wall 4 of the tank 2. The outlet 3 further has a shut-off valve 5. In the tank 2, a suction pipe 6 is arranged. The pipe 6 has a suction end 7 and a connection end 8. In the wall of connection end 8 of the pipe 6, a relief valve 9 is arranged. A joint 10 in the pipe 6 allows the suction end 7 to pivot around the connection end 8.

[0029] Attached to the suction end 7 is a float 11. Arrows indicate the direction of flow of the liquid 12 that is sucked into the suction end 7 of the pipe 6. Means, such as a pump, to suck in the liquid 12 are not depicted. Liquid contamination 13, such as water, and other contamination in the form of solids 14 are shown as well.

[0030] Figure 2A shows a detail I of the embodiment 1 depicted in figure 1, with the shut-off valve 5 in open position and the relief valve 9 in closed position. The relief valve 9 is depicted as a flap with a pivot 15 and lever 16. It can be seen that the flow of liquid indicated by the arrows, exerts a force on the lever 16, causing the flap to remain closed. This closing action is further aided by the pressure difference between the inside tank and the inside of the suction pipe.

[0031] Figure 2B shows a detail I of the embodiment 1 depicted in figure 1, with an alternative position of the valves 5, 9. The shut-off valve 5 is in closed position and the relief valve 9 is in open position. The flow of the liquid, pressurized by the liquid hammer effect, is diverted through the auxiliary passage 17 created by the opening of the relief valve 9, as indicated by the arrow. The flow can thus slowly stop, without causing a high pressure spike.

[0032] Figure 3 shows a schematic top-view of another embodiment 21 according to the invention, where the shut-off valve and the relief valve are combined in a diverter valve 25. The outlet 23 arranged in the wall 24 of the liquid tank can be closed by the diverter valve 25, which is arranged in the wall 24, or on the inside 38, of the tank. The diverter valve combines the function of the shut-off valve and the relief valve. When the outlet 23 is closed, the flow of liquid will flow through the auxiliary outlet 37, arranged on the inside 38 the tank.

[0033] Figure 4 shows a schematic top-view of an alternative embodiment 41 according to the invention, where the shut-off valve and the relief valve are combined in a diverter valve 45 placed on the outlet 43, arranged in the wall 44 of the tank. The diverter valve 45 is placed on the outside 59 of the tank, for easier maintenance. When the outlet 43 is closed by means of the diverter valve 45, the flow of liquid will flow through the auxiliary outlet 57, back into the inside 58 of the tank.

[0034] Figure 3 and 4 further emphasize different ways of creating an auxiliary flow path, depending on the position of the shut-off valve. Regulations may, for example in the petrochemical industry, require the shut-off valve to be arranged in the wall of the tank.

Claims

1. Combination of a liquid tank and a suction pipe, wherein the liquid tank comprises an outlet, wherein the outlet comprises a shut-off valve, and where the suction pipe is arranged within the liquid tank, wherein the suction pipe comprises a suction end and a connection end, and wherein the connection end of the suction pipe is connected to the outlet of the liquid tank, **characterized in that**, a relief valve is arranged in the wall of the suction pipe and adjacent to the connection end.

5
10
2. Combination according to claim 1, where the suction pipe comprises a joint arranged between the opening and the suction end, allowing the suction end to pivot around the joint, relative to the connection end.

15
3. Combination according to any of the preceding claims, wherein adjacent to the suction end a float is arranged.

20
4. Combination according to any of the claims 1 - 3, where both the shut-off valve and the relief valve comprise an open position and a closed position, and wherein the positions of both valves are coupled, such that the closed position of the relief valve corresponds with the open position of the shut-off valve and vice versa.

25
30
5. Combination according to any of the claims 1 - 3, where the relief valve is a non-return valve, wherein the flow direction of the non-return valve is directed from the inside towards the outside of the suction pipe.

35

40

45

50

55

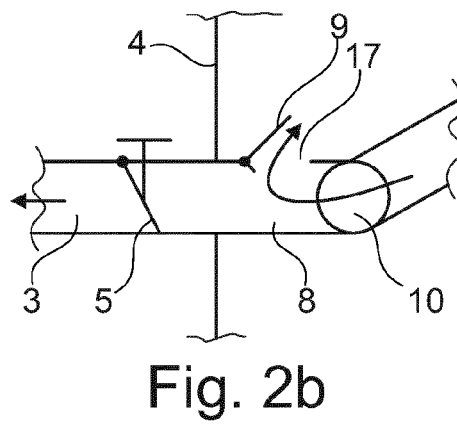
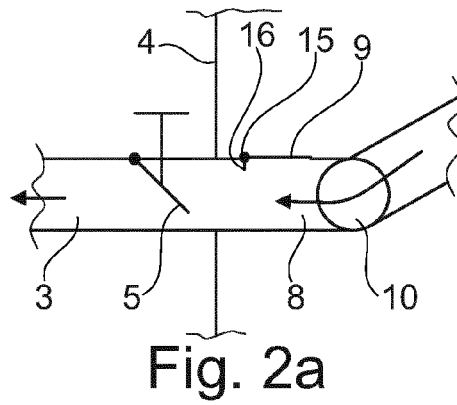
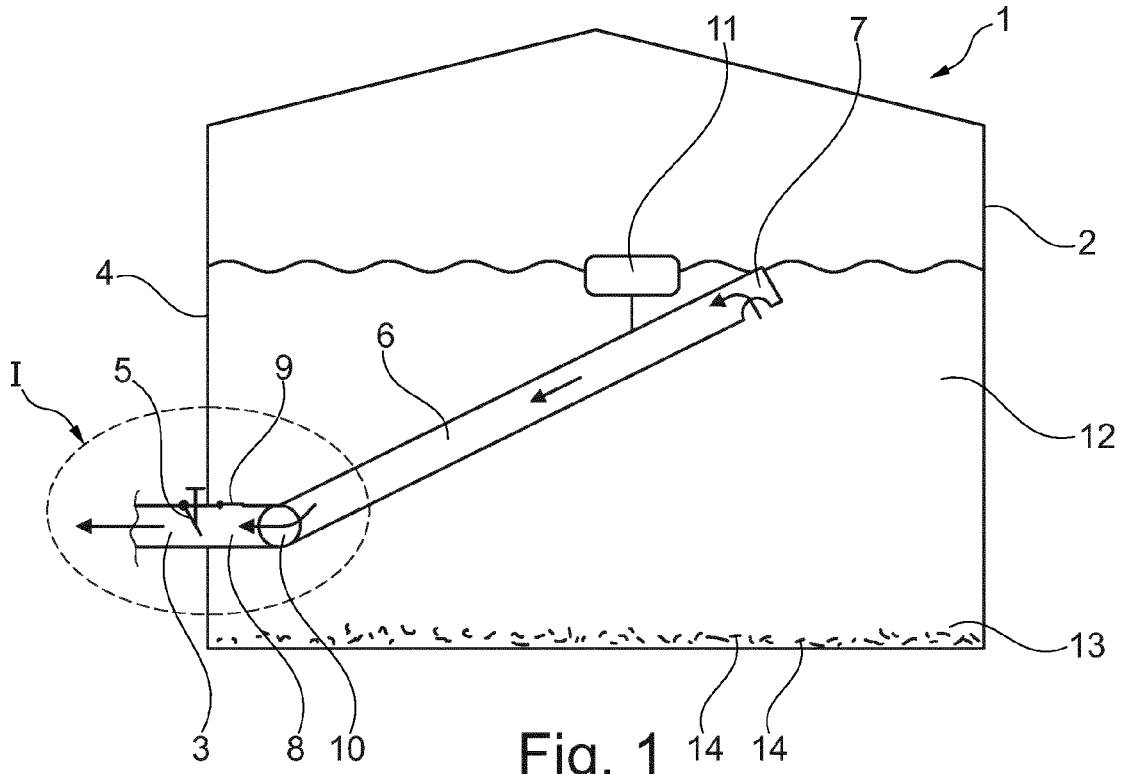

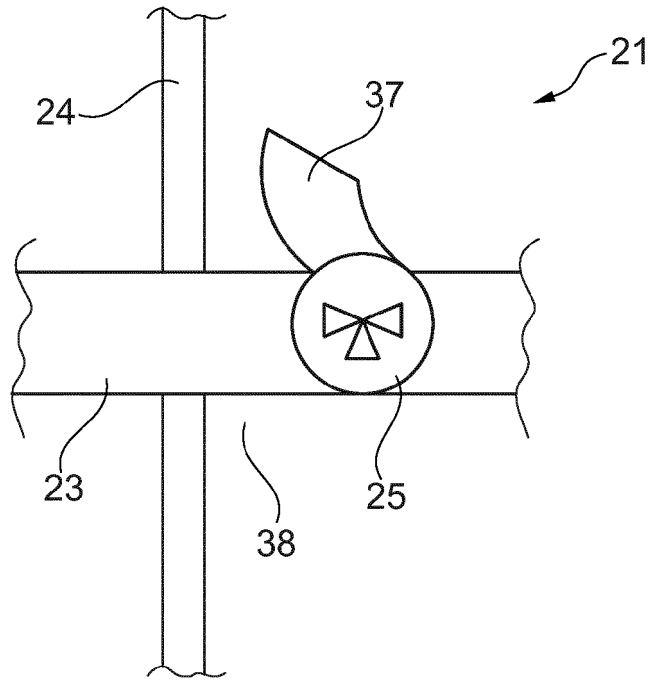

Fig. 3

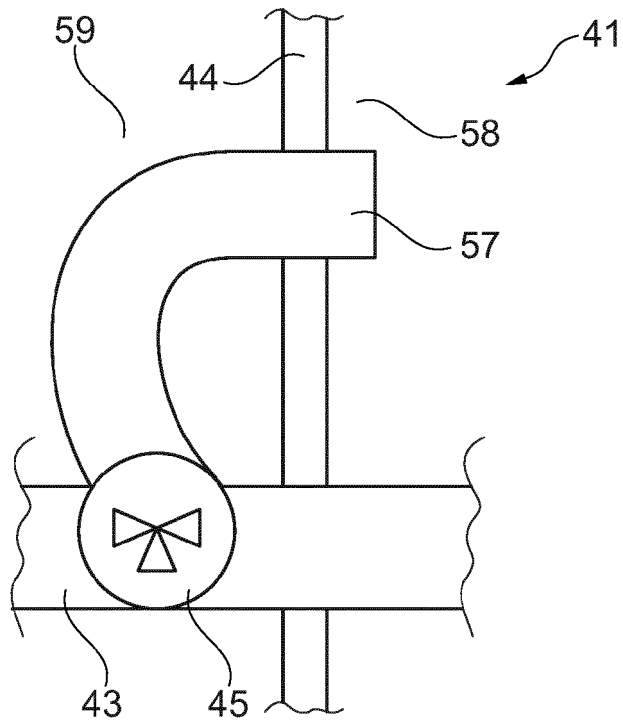

Fig. 4



EUROPEAN SEARCH REPORT

Application Number
EP 18 20 7087

5

10

15

20

25

30

35

40

45

50

55

DOCUMENTS CONSIDERED TO BE RELEVANT			
Category	Citation of document with indication, where appropriate, of relevant passages	Relevant to claim	CLASSIFICATION OF THE APPLICATION (IPC)
X A	EP 0 000 692 A1 (PASSAVANT WERKE [DE]) 21 February 1979 (1979-02-21) * page 3, line 24 - page 4, line 5 * * figure 1 * -----	1-3,5 4	INV. B65D88/54 B67D7/06
X A	US 5 522 415 A (HOPENFELD JORAM [US]) 4 June 1996 (1996-06-04) * column 6, lines 15-19 * * figure 2 * -----	1,5 4	
			TECHNICAL FIELDS SEARCHED (IPC)
			B65D B67D
The present search report has been drawn up for all claims			
Place of search Munich		Date of completion of the search 20 February 2019	Examiner Piolat, Olivier
CATEGORY OF CITED DOCUMENTS X : particularly relevant if taken alone Y : particularly relevant if combined with another document of the same category A : technological background O : non-written disclosure P : intermediate document		T : theory or principle underlying the invention E : earlier patent document, but published on, or after the filing date D : document cited in the application L : document cited for other reasons & : member of the same patent family, corresponding document	

EPO FORM 1503 03/82 (P04C01)

**ANNEX TO THE EUROPEAN SEARCH REPORT
ON EUROPEAN PATENT APPLICATION NO.**

EP 18 20 7087

5 This annex lists the patent family members relating to the patent documents cited in the above-mentioned European search report.
The members are as contained in the European Patent Office EDP file on
The European Patent Office is in no way liable for these particulars which are merely given for the purpose of information.

20-02-2019

10	Patent document cited in search report	Publication date	Patent family member(s)	Publication date
	EP 0000692 A1	21-02-1979	DE 7725257 U1 EP 0000692 A1	01-12-1977 21-02-1979
15	US 5522415 A	04-06-1996	NONE	
20				
25				
30				
35				
40				
45				
50				
55				

EPO FORM P0459

For more details about this annex : see Official Journal of the European Patent Office, No. 12/82

REFERENCES CITED IN THE DESCRIPTION

This list of references cited by the applicant is for the reader's convenience only. It does not form part of the European patent document. Even though great care has been taken in compiling the references, errors or omissions cannot be excluded and the EPO disclaims all liability in this regard.

Patent documents cited in the description

- US 3172581 A [0002]