



(11) **EP 3 666 989 A1**

(12) **EUROPEAN PATENT APPLICATION**

(43) Date of publication:  
**17.06.2020 Bulletin 2020/25**

(51) Int Cl.:  
**E04D 3/35<sup>(2006.01)</sup>** **E04D 5/14<sup>(2006.01)</sup>**  
**E04D 11/02<sup>(2006.01)</sup>**

(21) Application number: **19216433.3**

(22) Date of filing: **16.12.2019**

(84) Designated Contracting States:  
**AL AT BE BG CH CY CZ DE DK EE ES FI FR GB GR HR HU IE IS IT LI LT LU LV MC MK MT NL NO PL PT RO RS SE SI SK SM TR**  
Designated Extension States:  
**BA ME**  
Designated Validation States:  
**KH MA MD TN**

(72) Inventors:  
• **Mente, Markus**  
**1435 Mont Saint Guibert (BE)**  
• **Bonca, Metod**  
**1435 Mont Saint Guibert (BE)**

(74) Representative: **ARC-IP**  
**ARC-IP sprl**  
**Rue Emile Francqui 4**  
**1435 Mont-Saint-Guibert (BE)**

(30) Priority: **14.12.2018 GB 201820462**

(71) Applicant: **Knauf Insulation doo Skofja Loka**  
**4220 Skofja Loka (SI)**

(54) **MINERAL WOOL INSULATION**

(57) A flat roof insulating system comprising a weatherproof membrane secured to an insulating panel, characterised in that:  
- the insulating panel comprises one part of a hook and loop fastening system secured to its upper surface;  
- the weatherproof membrane comprises the other part

of the hook and loop fastening system secured to its lower major surface; and  
the weatherproof membrane is secured to the mineral wool insulating panel by the hook and loop fastening system.

Fig 2

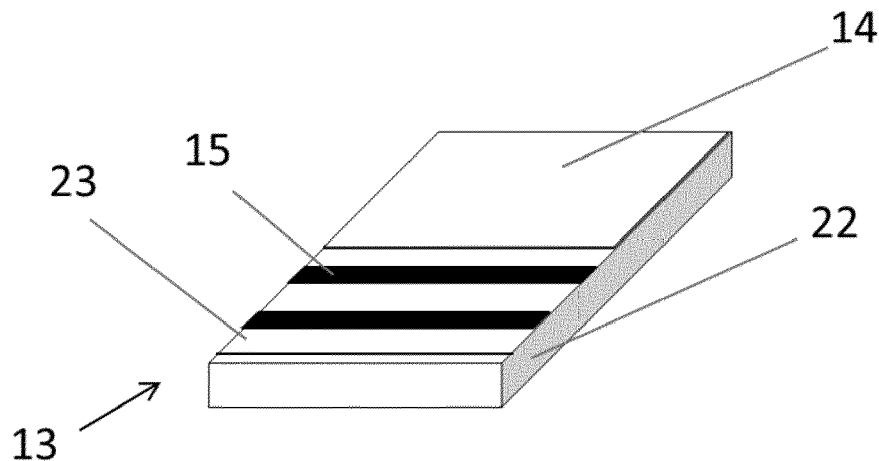

**EP 3 666 989 A1**

## Description

**[0001]** This invention relates to a system for insulating a flat roof.

**[0002]** One aim of the present invention is to provide a flat roof insulating system which provides an advantageous combination of ease of manufacturing, suitability for use in a flat roof system and good thermal and fire resistance properties.

**[0003]** In accordance with one of its aspects, the present invention provides a roof system as defined in claim 1. Additional aspects of the invention are defined in independent claims. The dependent claims define preferred and/or alternative embodiments.

**[0004]** In accordance with one of its aspects, the present invention provides a flat roof insulating system comprising a weatherproof membrane secured to a mineral wool insulating panel, characterised in that:

- the mineral wool insulating panel comprises i) a facing secured to its upper major surface and ii) one part of a hook and loop fastening system secured to the facing;
- the weatherproof membrane comprises the other part of the hook and loop fastening system secured to its lower major surface; and

the weatherproof membrane is secured to the mineral wool insulating panel by the hook and loop fastening system.

**[0005]** Flat roofs are roofs which are substantially horizontal. Flat roofs may have a slight slope, notably arranged to evacuate water, notably from rainfall; the slope may be less than 10°, less than 5° or less than 2°. The flat roof system may be a warm roof, for example, a warm roof with a built-up felt or asphalt roof covering, a warm roof with a single ply membrane or an inverted/protected membrane/green roof. A vapour control layer, for example a polymer sheet, polyethylene sheet, reinforced polyethylene sheet, bitumen layer or bitumen bonded felt, may be provided between the upper surface of the roof and the mineral wool insulation panel.

**[0006]** The mineral wool insulation panel may comprise  $\geq 80\%$ wt, preferably  $\geq 90\%$ wt, more preferably  $\geq 95\%$ wt of mineral wool fibres. The mineral wool fibres may comprise glass wool fibres and/or stone wool fibres (also called rock wool fibres). In a preferred embodiment, the mineral wool preferably comprises stone wool fibres.

**[0007]** The stone wool mineral fibres may comprise: between 30 and 55 wt-% SiO<sub>2</sub> and/or between 10 and 30 wt-% Al<sub>2</sub>O<sub>3</sub>; and/or an alkali/alkaline-earth ratio of their composition which is  $< 1$ ; and/or a combined quantity of CaO and MgO ranging from 20 to 35 wt-%; and/or a combined quantity of Na<sub>2</sub>O and K<sub>2</sub>O  $< 8$  wt%; and/or a total iron content expressed as Fe<sub>2</sub>O<sub>3</sub> of between 4 and 10 wt-%. The stone wool fibres may have a softening point in the range 900-1200°C, notably in the range 1000-1100°C. The amount of shots (or beads) in the min-

eral wool blanket may be  $\leq 1\%$ wt, a shot being defined as a particle having a largest apparent diameter of less than 60 $\mu$ m.

**[0008]** The glass mineral wool fibres may comprise:  $> 55$  wt-% silicon oxide (SiO<sub>2</sub>) and/or  $< 10$  wt-% aluminium oxide (Al<sub>2</sub>O<sub>3</sub>); and/or an alkali/alkaline-earth ratio of their composition which is  $> 1$ ; and/or a combined quantity of CaO and MgO  $< 20$  wt-%; and/or a combined quantity of Na<sub>2</sub>O and K<sub>2</sub>O  $> 8\%$ wt. The glass wool fibres may have a softening point in the range 600-750°C, notably in the range 650-700°C.

**[0009]** The mineral wool insulating panel may have:

- a density which is  $\geq 80$  kg/m<sup>3</sup> or  $\geq 90$  kg/m<sup>3</sup> and/or which is  $\leq 220$  kg/m<sup>3</sup> or  $\leq 200$  kg/m<sup>3</sup>; and/or
- a thermal conductivity which is  $\leq 40$  mW/m.K or  $\leq 39$  mW/m.K and/or  $\geq 30$  mW/m.K; and/or
- a weight which is  $\geq 5$  kg/m<sup>2</sup> or  $\geq 15$  kg/m<sup>2</sup> and/or which is  $\leq 40$  kg/m<sup>2</sup>.

**[0010]** The mineral wool insulation panel may comprise a dual density mineral panel, that is to say a mineral wool panel comprising a high density surface layer of mineral wool fibres (notably having i) a thickness which is  $\geq 5$ mm and/or  $\leq 40$  mm and/or ii) a density which is  $\geq 130$  kg/m<sup>3</sup> and/or  $\leq 250$  Kg/m<sup>3</sup>) and a lower density underlying layer of mineral wool fibres (notably having i) a thickness which is  $\geq 45$ mm and/or  $\leq 400$  mm and/or ii) a density which is  $\geq 100$  kg/m<sup>3</sup> and/or  $\leq 185$  kg/m<sup>3</sup>). The flat roof system may comprise a single layer of mineral wool insulation panels or a plurality of layers comprising a stack of individual mineral wool panels.

**[0011]** The mineral wool insulation panel may comprise a mineral wool binder which serves to hold its individual fibres together, notably an organic, thermoset binder. The mineral wool binder may make up  $\geq 2$  wt%,  $\geq 2.5$  wt% or  $\geq 3$  wt% and/or  $\leq 7$  wt% or  $\leq 6$  wt% or  $\leq 5$  wt% of the mineral wool insulation panel. The binder content may be determined by LOI (loss on ignition). Preferably, the mineral wool binder and the mineral wool insulation panel are formaldehyde free. In particular, the mineral wool binder is preferably not a phenol formaldehyde binder. The mineral wool insulation panel (comprising the mineral wool binder) preferably comprises less than 5 ppm or less than detectable limits of free formaldehyde and/or consist of materials which together comprise less than these amounts of free formaldehyde and/or releases levels of formaldehyde in standardised tests adapted to simulate ordinary use which allows it to be classified as having no or undetectable levels of formaldehyde release. Preferably, such products release less than 10 $\mu$ g/m<sup>3</sup>, more preferably less than 5  $\mu$ g/m<sup>3</sup> of formaldehyde during the period of 24-48 hours from the start of testing in accordance with ISO 16000. The mineral wool binder may be a sugar based binder, that is to say a binder which is the reaction product(s) of a binder solution whose solid content comprises at least 50 wt% sugar(s). The mineral wool binder may be the reaction

product(s) of a binder solution whose solid content comprises at least 70 wt% reducing sugar(s), preferably in combination with a source of nitrogen to form a Maillard reaction product, notably in combination with preferably at least 10 wt% of i) amine(s) and/or ii) carboxylic acid(s).

**[0012]** The fibres of the mineral wool insulation panel may be orientated substantially perpendicular to the panel's major surfaces; they may be crimped. Particularly when the mineral wool insulating panel comprises glass wool fibres, the glass wool fibres may be crimped. The mineral wool insulation panel may have a crimp factor which is  $\geq 1.1$ ,  $\geq 1.2$ ,  $\geq 1.3$ ,  $\geq 1.5$  or  $\geq 2$  and/or  $\leq 4$  or  $\leq 3.5$ . The crimp factor provides an indication of the degree of crimping and thus of fibre re-orientation; it may be assessed by comparing i) the manufacturing line speed of the mineral wool prior to crimping, notably the line speed of the secondary blanket in the case of stone wool insulation with ii) the manufacturing line speed of the mineral wool panel after crimping, notably the line speed of the mineral wool blanket through the curing oven. A crimp factor of 3 indicates a line speed after curing of 1/3 of the line speed prior to crimping. The mineral wool insulation panel preferably has a compressive strength which is  $\geq 30$  kPa,  $\geq 40$  kPa or  $\geq 55$  kPa, notably  $\geq 58$  kPa and/or  $\leq 120$  kPa, or  $\leq 100$  kPa. Compression strength and other properties of the mineral wool insulation panel should be measured in accordance with EN13162 and the specific standards referred to therein. The mineral wool insulation panel preferably has a tensile resistance which is  $\geq 5$  kPa,  $\geq 10$  kPa and/or  $\leq 40$  kPa, or  $\leq 30$  kPa. Tensile resistance and other properties of the mineral wool insulation panel should be measured in accordance with EN13162:2012:A1+2015 and the specific standards referred to therein.

**[0013]** The mineral wool insulation panel preferably has a fire classification of at least Euroclass A2, preferably of at least A1 as determined under EN 13501-1.

**[0014]** The facing may be a veil, for example a woven veil or a non-woven veil. In a preferred embodiment, the facing is a non-woven veil. The facing may cover at least 80%, at least 85%, at least 90%, at least 95%, at least 99% or all of the upper surface of the mineral wool insulating panel. Such covering facilitates the manufacturing process of the mineral wool insulating panel. Preferably the facing is secured to the upper surface of the mineral wool insulation panel by the same binder as that present in the mineral wool insulation panel. In a preferred manufacturing method, the facing is applied to the upper surface of a mineral wool batt as the batt moves along a manufacturing line, preferably without applying additional binder, and binder present in the batt secures the facing and the batt together during passage through a curing oven to cure the binder. Notably for use in such a method, the facing is preferably provided with openings; such openings facilitate curing of the batt in such a method by facilitating passage of heated air through the facing covered batt. Alternatively, the facing may not be passed through a curing oven; it may be secured to the upper

surface of the mineral wool insulation panel after the mineral wool has passed through a curing oven. The binder by which the facing is secured to the upper surface of the mineral wool insulation panel may be a hot melt binder, a thermoset binder, an organic binder, an inorganic binder, a poly(vinyl acetate) binder, a polyurethane binder or a water glass binder. It may be a binder as described above in relation to mineral wool binders, notably a binder that is formaldehyde free and which is not a phenol formaldehyde binder. The binder by which the facing is secured to the upper surface of the mineral wool insulation panel may be present in an amount which is  $\geq 5$  g/m<sup>2</sup>,  $\geq 10$  g/m<sup>2</sup>,  $\geq 15$  g/m<sup>2</sup>,  $\geq 30$  g/m<sup>2</sup>,  $\geq 40$  g/m<sup>2</sup>,  $\geq 50$  g/m<sup>2</sup> or 75g/m<sup>2</sup> and/or  $\leq 300$  g/m<sup>2</sup>,  $\leq 200$ g/m<sup>2</sup>,  $\leq 150$ g/m<sup>2</sup>.

**[0015]** Whilst not wishing to be bound by theory, it is believed that the presence of the facing facilitates and improves the adhesion of the one part of the hook and loop fastening system to the mineral wool insulation panel.

**[0016]** The openings in the facing, when present, may make up a portion of the surface area of the facing which is  $\geq 5\%$ ,  $\geq 10\%$ ,  $\geq 15\%$ ,  $\geq 20\%$ ,  $\geq 25\%$ ,  $\geq 30\%$ ,  $\geq 35\%$ ,  $\geq 40\%$  or  $\geq 45\%$  and/or  $\leq 95\%$ ,  $\leq 90\%$ ,  $\leq 85\%$ ,  $\leq 80\%$ ,  $\leq 75\%$  or  $\leq 70\%$ .

**[0017]** Where the facing is a veil, the fibres of the veil are held together by a veil binder; this may be a thermoset binder. The veil binder may comprise a PVC binder or a PVC based binder. The veil binder may be a binder as described above in relation to mineral wool binders; it may comprise  $\geq 5$  wt% or  $\geq 8$  wt% and/or  $\leq 30$  wt% or  $\leq 28$  wt% of the non-woven veil. The facing may comprise a flame retardant, for example comprising a phosphate, borate, hydroxide or aluminium hydroxide. The facing, notably when this is a veil, preferably comprises a filler, notably an inorganic filler, for example comprising calcium oxide, calcium hydroxide, aluminium hydroxide, clay, talc, magnesium silicate, hydrated magnesium silicate or mixtures thereof. The filler, or the combination of filler and flame retardant, may comprise  $\geq 10$  wt%, or  $\geq 15$  wt% or  $\geq 20$  wt% or  $\geq 25$  wt% and/or  $\leq 80$  wt%, or  $\leq 70$  wt%, or  $\leq 60$  wt% of the veil. The veil may be formed by applying the filler to a veil having a weight which is  $\geq 30$  g/m<sup>2</sup> or  $\geq 40$  g/m<sup>2</sup> or  $\geq 45$  g/m<sup>2</sup> and/or  $\leq 100$ g/m<sup>2</sup>, or  $\leq 80$ g/m<sup>2</sup>, or  $\leq 70$ g/m<sup>2</sup>. The veil, including the filler, may have a weight which is  $\geq 100$  g/m<sup>2</sup> or  $\geq 150$  g/m<sup>2</sup> or  $\geq 200$  g/m<sup>2</sup> or  $\geq 250$  g/m<sup>2</sup> or  $\geq 300$  g/m<sup>2</sup> and/or  $\leq 500$  g/m<sup>2</sup>, or  $\leq 450$  g/m<sup>2</sup> or  $\leq 400$  g/m<sup>2</sup>. For example, the veil (including any filler and coating) may have a weight which is  $\geq 200$  g/m<sup>2</sup> or  $\geq 250$  g/m<sup>2</sup> and/or  $\leq 350$  g/m<sup>2</sup> or  $\leq 400$  g/m<sup>2</sup>. The veil may comprise a water repellent or hydrophobic agent, for example a fluorocarbon, which may comprise  $\geq 0.5$  wt% or  $\geq 1$  wt% and/or  $\leq 2$  wt% or  $\leq 1.5$  wt% of the veil; this may form part of the veil binder. Where the filler comprises talc, this may provide hydrophobic characteristics to the veil. Where the filler comprises Al<sub>2</sub>O<sub>3</sub>, this may provide fire resistant characteristics to the veil. The veil may be coated on only one of its major surfaces or it may be coated on each of its two major surfaces; the

coating may comprise a filler and/or a flame retardant and/or a water repellent or hydrophobic agent, notably as described above. The fibres of the veil may be selected such that at least 80% of the fibres by weight have a diameter which is: AA 0.8-1-2 $\mu$ m; A 1.2-2.5 $\mu$ m; B 2.5-3.8  $\mu$ m; C 3.8-5.0  $\mu$ m; D 5.0-6.4  $\mu$ m; E 6.4-7.6  $\mu$ m; F 7.6-9.0  $\mu$ m; G 9.0-10.2  $\mu$ m; H 10.2-11.4  $\mu$ m or J 11.4-12.7  $\mu$ m. The veil may have a width which is  $\geq 1.5$  m or  $\geq 1.8$  m and/or  $\leq 2.6$  m or  $\leq 2.4$  m. The veil may be supplied in the form of a roll; this facilitates application to the mineral wool insulation panel. Such a roll may have: an external diameter which is  $\geq 0.5$  m or  $\geq 0.8$ m and/or  $\leq 1.6$  m or  $\leq 1.4$  m; it may comprise a continuous length of veil which is  $\geq 800$  m or  $\geq 1000$  and/or  $\leq 2000$  m or  $\leq 1800$  m. A preferred facing is a veil having at least the following features:

- the veil is a non-woven veil;
- the non-woven veil comprises glass fibres and inorganic filler held together by a thermoset veil binder;
- the glass fibres are selected such that at least 80% of the fibres by weight have a diameter which is AA 0.8-1-2 $\mu$ m; A 1.2-2.5 $\mu$ m ;
- the non-woven veil is formed by applying the inorganic filler to a non-woven veil having a weight which is  $\geq 40$  g/m<sup>2</sup> and  $\leq 70$ g/m<sup>2</sup>.

**[0018]** The weatherproof membrane may comprise a single ply membrane. It may be selected from a bitumen membrane, a fully bonded built-up bitumen membrane, mastic asphalt, a polymer membrane, a PVC membrane; an EPDM (ethylene propylene diene terpolymer) membrane.

**[0019]** The surface of the mineral wool insulation panel to which the facing is secured may have a point load resistance (measured in accordance with EN12430) which is  $\geq 300$  N,  $\geq 450$ ,  $\geq 650$  N,  $\geq 750$  N,  $\geq 800$  N or  $\geq 900$  N.

**[0020]** The flat roof system may comprise anchors, notably mechanical fixations, for example plastic or metallic anchors, to secure the flat roof insulating system, particularly the mineral wool insulating panel, to the flat roof, particularly a bearing constructions (for example concrete, steel or wood) of the flat roof. In preferred embodiments, no such anchors are used. Preferably, the weight of the mineral wool insulating panel, notably in combination with the weight of the membrane, renders additional anchoring of the mineral wool panels to the roof structure unnecessary. Preferably, attachment of the weatherproof membrane to the mineral wool panels consists of attachment by the hook and loop fastening system; this attachment between the weatherproof membrane and the mineral wool insulation panel preferably provides sufficient peel strength, notably sufficient peel strength to avoid undesired displacement of the weatherproof membrane, for example by wind. Alternatively, the flat roof system, notably the mineral wool insulating panel, is secured to the roof and/or to the bearing construction with

an adhesive. When adhesive is used, the tensile resistance between the mineral wool insulating panel and the flat roof and/or the bearing construction may be at least 5kPa as determined by EN1607. In other embodiments, between one and four anchors are used per mineral wool insulation panel; common know comparable roof systems require a greater number of anchors; preferably at least two anchors are used. The force required to pull through an anchor out of the bearing construction may be at least 200N, preferably at least 400N, as determined by ETAG 004.

**[0021]** Facings used in accordance with the present invention, particularly in their preferred forms, provide a valuable combination of advantages, notably:

- on-site protection of the mineral panel prior to completion of the building structure, the exposed veil reducing water ingress into the mineral wool insulating panel and/or providing UV protection;
- mechanical properties, notably a high resistance of the mineral wool insulating panels to point loads before and/or after placement of an overlying weatherproof membrane.

**[0022]** The one part of the hook and loop fastening system, secured to the mineral wool insulating panel, may be provided in the form of strips, patches or a layer covering substantially at least 80%, at least 90% or the whole upper surface of the mineral wool insulating panel. Particularly where part of the hook and loop fastening system is discontinuous, for example when provided in the form of patches or strips, the discontinuous part of the hook and loop fastening system makes up between 20% and 80% of the surface area of the upper surface of the insulating panel to which it is attached.

**[0023]** Particularly when the one part of a hook and loop fastening system is provided in the form of strips, for example provided on the upper major surface of the mineral wool insulating panel, there may be at least two, three or four strips, preferably equally spaced apart from each other. In a preferred embodiment, the upper major surface of the mineral wool insulating panel is substantially rectangular and the strips are provided parallel to the shorter sides of the mineral wool insulating panel. This may be particularly advantageous when the weatherproof membrane is in the form of a roll which is unrolled in the length direction of the mineral wool insulating panel, ie unrolled in the direction parallel to the longer sides. Alternatively, the strips may be provided parallel to the longer sides of the mineral wool insulating panel. The strips may have a width of at least 20 mm, at least 30 mm and/or less than 100 or less than 80mm. The distance separating two adjacent strips at their closest points may be at least 100mm, at least 150mm, or at least 300mm and/or less than 2000mm, less than 1000mm or less than 700mm. In a preferred embodiment, when the strips have a width in the range 30-80, the distance between two adjacent strips may be in the range 150-1000. This pro-

vides an efficient ratio between the amount of hook and loop fastening system used and the desired peel strength for securing the weatherproof membrane to the mineral wool insulating panel. Preferably, the shortest distance from an edge of the first and last strips to each of their respective spaced side edges of the mineral wool insulating panel is at least 40mm or at least 50mm. This facilitates manufacturing of the mineral wool panel by avoiding cutting of the mineral wool insulating panel at a position where one part of the hook or loop fastening system is provided in the form of the a strip secured to the upper surface of the mineral wool insulating panel. Preferably, each strip extends between and up to the edge of opposed sides of the upper major surface of the mineral wool insulating panel.

**[0024]** The other part of a hook and loop fastening system, secured to the weatherproof membrane, may be provided in the form of strips, patches or a layer covering substantially at least 80%, at least 90% or the whole lower surface of the weatherproof membrane. Particularly where part of the hook and loop fastening system is discontinuous, for example when provided in the form of patches or strips, the discontinuous part of the hook and loop fastening system makes up between 20% and 80% of the surface area of the lower surface of the weatherproof membrane to which it is attached. In a preferred embodiment, part of a hook and loop fastening system is provided in the form of a layer covering at least 80%, at least 90% or preferably the whole lower surface of the weatherproof membrane. This facilitates manufacturing of the weatherproof membrane and installation of the weatherproof membrane on site, notably where the other part of the hook and loop fastening system is provided in a discontinuous form, for example as strips, at the major surface of the mineral wool insulating panels as the weatherproof membrane does not need to be aligned in an particular orientation with respect to the mineral wool insulating panels for correct attachment.

**[0025]** When the weatherproof membrane and the mineral wool insulating panel are secured by the hook and loop fastening system, the fastened contact surface between the hooks and the loops may be at least 20%, with respect to the total contact surface between the weatherproof membrane and the mineral wool insulating panel. Preferably, the fastened contact surface is homogeneous over the whole contact surface between the weatherproof membrane and the mineral wool insulating panel, which means that the variation of fastened contact surface is  $\leq 20\%$ ,  $\leq 15\%$  or  $\leq 10\%$  when analysing  $0.1\text{m}^2$  of contact surface at two locations spaced apart by at least 60cm or at least 1m. This provides a homogeneous peel strength over the whole contact surface between the weatherproof membrane and the mineral wool insulating panel.

**[0026]** The hook and loop fastening system may be secured to the mineral wool insulating panel and/or to the weatherproof membrane by an adhesive. The adhesive may comprise EVA, PU, copolymer, copolyesters

and combination thereof. The adhesive may be a hot melt adhesive. The peel strength at  $90^\circ$  between :

- i) the part of the hook and loop fastening system secured to the facing and ii) the facing; and/or
- i) the part of a hook and loop fastening system secured to the weatherproof membrane and ii) the weatherproof membrane; and/or
- between the two parts of the hook and loop fastening system once the weatherproof membrane is secured to the mineral wool insulating panel,

may be at least 0.01daN/cm, at least 0.040 daN/cm, at least 0.1 daN/cm and/or less than 100 daN/cm, less than 50 daN/cm, less than 10 daN/cm or 6 daN/cm, as determined by EN 28510. This provides sufficient resistance for the flat roof system and avoids undesired displacement of any part of the flat roof system, for example by strong wind. The hook and loop fastening system may be secured to the mineral wool insulating on the construction site or during the production process of the mineral wool insulating panel. Preferably, the hook and loop fastening system is secured to the mineral wool insulating and to the weatherproof membrane during the production process of each of the mineral wool insulating panel and of the weatherproof membrane. This facilitates installation as it provides the combined part of the hook and loop fastening system ready for delivery to and use on a building site.

**[0027]** In a preferred embodiment, the hook part of the hook and loop fastening system is provided on the upper surface of the mineral wool insulating panel, notably in the form of strips, and the loop part of the hook and loop fastening system is provided on the lower surface of the weatherproof membrane, notably in the form of a layer covering substantially at least 80% of its lower surface. This configuration facilitates handling of the weatherproof membrane, particularly when the weatherproof is in the form of a roll having its part of the hook and loop fastening system arranged at its externally rolled surface. Alternatively, the loop part of the hook and loop fastening system may be provided on the upper surface of the mineral wool insulating panel, notably in the form of strips, and hook part of the hook and loop fastening system may be provided on the lower surface of the weatherproof membrane, notably in the form of a layer covering substantially at least 80% of its lower surface.

**[0028]** In a preferred embodiment, the manufacturing process of part of the flat roof insulating system comprises, notably in this order:

- manufacturing a mineral wool blanket comprising mineral wool fibres and uncured mineral wool binder;
- providing on the upper surface of the mineral wool blanket a facing, notably a non-woven veil which may comprise an adhesive on it lower surface, the facing preferably covering at least 80% or all of the upper surface of the mineral wool blanket;

- curing the mineral wool blanket with the facing on its upper surface during passage through a curing oven thus forming a cured mineral wool insulating blanket;
- removing the mineral wool insulating blanket from the curing oven;
- securing, notably by an adhesive, part of a hook and loop fastening system to the facing of the mineral wool insulating blanket; and
- cutting the mineral wool mineral wool blanket in to mineral wool insulating panels.

**[0029]** Preferably, the part of the hook and loop fastening system secured to the facing of the mineral wool is secured in continuous lengths, notably by being unwound on to the facing of the mineral wool blanket as the mineral wool blanket advances along the manufacturing line, in particular by being unwound in the direction of travel of the mineral wool blanket. The ability to apply the part of the hook and loop fastening system secured to the facing in a continuous on-line process facilitates manufacturing. Alternatively, the part of the hook and loop fastening system secured to the facing may be secured to the facing on mineral wool insulating panels subsequent to the mineral wool blanket having been cut to form the mineral wool insulating panels; this may be used for off-line attachment of the part of the hook and loop fastening system secured to the facing, for example for speciality products.

**[0030]** In accordance to another aspect of the invention there is provided a method of insulating a flat roof comprising:

- providing mineral wool insulating panels comprising one part of a hook and loop fastening system secured to its upper major surface;
- providing a weatherproof membrane comprising the other part of the hook and loop fastening system secured to its lower major surface;
- arranging the insulating panels at the flat roof; and
- subsequently extending the weatherproof membrane over the insulating panels and securing the membrane to the insulating panels by the hook and loop fastening system.

**[0031]** Preferably, the weatherproof membrane is provided in the form of a roll having its part of the hook and loop fastening system arranged at its externally rolled surface. This is advantageous as the part of the hook and loop fastening system is directly arranged towards the lower surface of the weatherproof membrane when unrolling the roll of weatherproof on the upper surface of the mineral wool insulating panel, thus facilitating its installation.

**[0032]** An embodiment of the invention will now be described, by way of example only, with reference to the accompanying drawing of which:

Fig 1 is a schematic side view of a warm roof system;

Fig 2 is a schematic, partially cut away perspective view of a flat roof insulation panel according to the invention;

Fig 3 is a schematic, partially cut away perspective view of a further embodiment of a flat roof insulation panel according to the invention; and

Fig 4 is a schematic perspective view of a peel strength test.

**[0033]** The warm deck, single ply roof system 10 of Fig 1 comprises (in sequence from the interior to the exterior of a building) a support structure 11 provided by a metal deck, an optional vapour control layer 12, a mineral wool insulation panel comprising a mineral wool core 22 and a non-woven veil 23, a plurality of spaced hook strips 15 secured to the veil by an adhesive (not shown) and an overlying weatherproof membrane 14 comprising a polymer layer 14a and a loop layer 14b. The single ply membrane 14 is secured to the mineral wool panel 13 by the hooks 15 and loops 14b which form a hook and loop fastening system. The distance  $d_1$  which separates two adjacent hook strips is about 60mm and the width  $w$  of each hook strips is about 40mm.

**[0034]** As shown in Fig 2, the flat roof insulation system 13 comprises a core 22 of mineral wool fibres provided on its upper surface with a non-woven veil 23. The non-woven veil 23 is manufactured by applying an inorganic filler comprising talc to a glass veil having a weight of about  $50 \text{ g/m}^2$  and comprising glass fibres (diameter AA: 0.8 to  $1.2 \mu\text{m}$ ) retained together by a veil binder. The veil is applied to the mineral wool insulation blanket prior to passage through a curing oven so that binder present in the mineral wool panel secures the facing 23 to the mineral wool insulation blanket upon curing.

**[0035]** Subsequent to exit from the curing oven strips 15 forming the hook part of the hook and loop fastening system are secured to the veil 23 and the blanket is cut into mineral wool insulating panels. At the building site, once the mineral wool insulating panels have been arranged at the flat roof, weatherproof membrane 14 is secured to the mineral wool insulating panel, the loop part of the hook and loop fastening system (not shown) covering the whole lower major surface of the weatherproof membrane.

**[0036]** In the embodiment shown in Fig 3, the strips 15 forming the hook part of the hook and loop fastening system secured to the veil 23 run parallel to the long sides of the rectangular upper major surface of the mineral wool insulating panel.

**[0037]** As shown in Fig.4, a peel strength test at  $90^\circ$  of a substrate 42 with respect of a coating 43 is illustrated. An adhesive tape 41 secured the coating and the substrate on the coating to a pull-off table 44. In order to conduct the peel strength test, the adhesive tape shall have a peel strength greater than the peel strength of the substrate. The substrate and coating have both a width of, for example, about 2 cm. If the minimum force for removing the substrate from the coating is about 100

daN, the peel strength is thus about 50 daN/cm. Similarly, if the width of the substrate/coating would have been about 4 cm and the minimum force still 100 daN, the peel strength would be about 25 daN/cm.

### Claims

1. A flat roof insulating system comprising a weatherproof membrane secured to a mineral wool insulating panel, **characterised in that:**

- the mineral wool insulating panel comprises i) a facing secured to its upper major surface, the facing preferably covering at least 80% or all of the upper surface of the mineral wool insulating panel and ii) one part of a hook and loop fastening system secured to the facing, notably by an adhesive;
- the weatherproof membrane comprises the other part of the hook and loop fastening system secured to its lower major surface, notably by an adhesive; and

the weatherproof membrane is secured to the mineral wool insulating panel by the hook and loop fastening system.

2. A flat roof insulating system in accordance with claim 1, in which the facing comprises a non-woven veil comprising a filler, notably selected from calcium oxide, calcium hydroxide, aluminium hydroxide, clay, talc, magnesium silicate, hydrated magnesium silicate and mixtures thereof, which at least partially obstructs interstices between fibres of the veil.
3. A flat roof insulating system in accordance with any preceding claim, in which the facing comprises openings making up between 15% and 85% of its surface area.
4. A flat roof insulating system in accordance with any preceding claim, in which the weight of the veil, including the filler, is  $\geq 100 \text{ g/m}^2$  and  $\leq 500 \text{ g/m}^2$ , notably  $\geq 250 \text{ g/m}^2$  and  $\leq 400 \text{ g/m}^2$ .
5. A flat roof insulating system in accordance with any preceding claim, in which the facing comprises a veil comprising fibres selected from: glass fibres; and a combination of glass fibres and polymer fibres, notably PE fibres, notably in which the combination of fibres comprises between 70 wt% and 90 wt% glass fibres and between 30 wt% and 10 wt% polymer fibres.
6. A flat roof insulating system in accordance with any preceding claim, in which at least one part of the hook and loop fastening system is provided in the

form of discontinuous patches, strips, layers or combination thereof.

7. A flat roof insulating system in accordance with claim 6, in which the discontinuous part of the hook and loop fastening system makes up between 20% and 80% of the surface area of the lower surface of the weatherproof membrane or the upper surface of the insulating panel to which it is attached.
8. A flat roof insulating system in accordance with any preceding claim, in which the mineral wool insulating panel has at least one of the following features:
- a density which is  $\geq 80 \text{ kg/m}^3$  or  $\geq 90 \text{ kg/m}^3$  and/or which is  $\leq 220 \text{ kg/m}^3$  or  $\leq 200 \text{ kg/m}^3$ ;
  - a surface of the mineral wool insulation panel to which the facing is secured having point load resistance (measured in accordance with EN12430) which is  $\geq 300 \text{ N}$ ,  $\geq 450$ ,  $\geq 650 \text{ N}$ ,  $\geq 750 \text{ N}$ ,  $\geq 800 \text{ N}$  or  $\geq 900 \text{ N}$ ;
  - a fire classification of at least Euroclass A2, preferably at least A1, as determined under EN 13501-1.
9. A flat roof insulating system in accordance with any preceding claim, in which:
- one part of the hook and loop fastening system, notably the hook part, is provided in the form of discontinuous patches, strips, layers or combination thereof on the upper surface of the mineral wool insulating panel, notably making up between 20% and 80% of the surface area of the lower surface of the weatherproof membrane; and
  - the other part of the hook and loop fastening system, notably the loop part, is provided in the form of a layer covering at least 80% of the lower surface of the weatherproof membrane.
10. A flat roof insulating system in accordance with any preceding claim, in which
- the one part of the hook and loop fastening system is secured to the facing by an adhesive; and/or
  - the other part of the hook and loop fastening system is secured to the lower major surface of the weatherproof membrane by an adhesive.
11. A flat roof insulating system in accordance with claim 10, in which the adhesive is a hot-melt adhesive or the adhesive comprises EVA, PU, copolymer, copolyesters and combination thereof.
12. A method of insulating a flat roof comprising:

- providing mineral wool insulating panels comprising one part of a hook and loop fastening system secured to its upper major surface, notably a mineral wool insulating panels comprising a facing secured to its upper major surface and one part of a hook and loop fastening system secured, notably by an adhesive, to the facing ; 5
  - providing a weatherproof membrane comprising the other part of the hook and loop fastening system secured, notably by an adhesive, to its lower major surface; 10
  - arranging the insulating panels at the flat roof; and
  - subsequently extending the weatherproof membrane over the insulating panels and securing the membrane to the insulating panels by the hook and loop fastening system. 15
- 13.** A method in accordance with claim 12, in which the flat roof insulating system is a flat roof insulating system in accordance with any of claims 1 to 11. 20
- 14.** A method in accordance with claim 12 or claim 13, in which the weatherproof membrane is provided in the form of a roll having its part of the hook and loop fastening system arranged at its externally rolled surface; and 25
- in which extending the weatherproof membrane over the insulating panels comprises contacting a portion of the external surface of the roll of weatherproof membrane with the insulating panels and subsequently unrolling the weatherproof membrane over the insulating panels. 30
- 15.** Use of a hook and loop fastening system for securing a weatherproof membrane to an mineral wool insulating panel in a flat roof system, notably a flat roof system in accordance with any of claims 1 to 11 or manufactured in accordance with the method of claims 12 to 14. 35 40

45

50

55

Fig 1

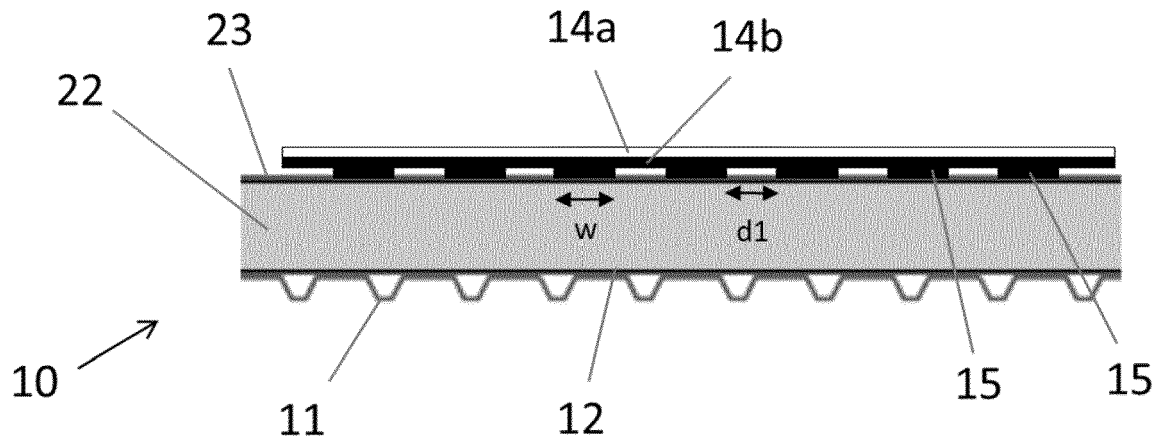

Fig 2

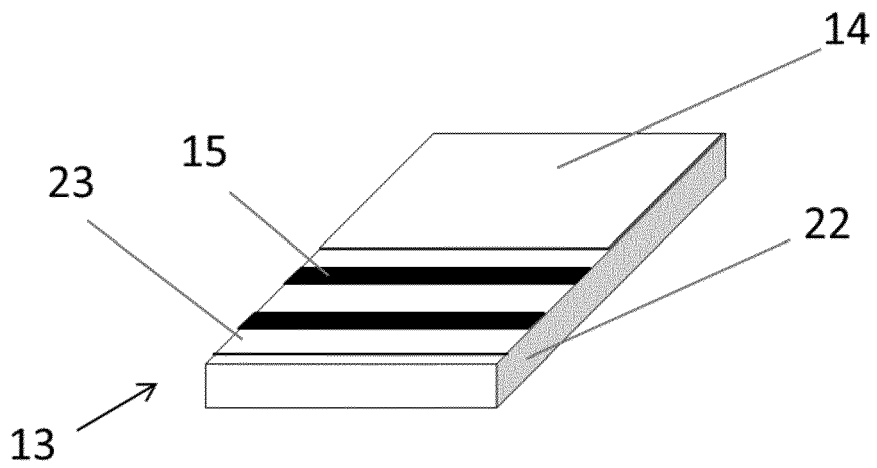

Fig 3

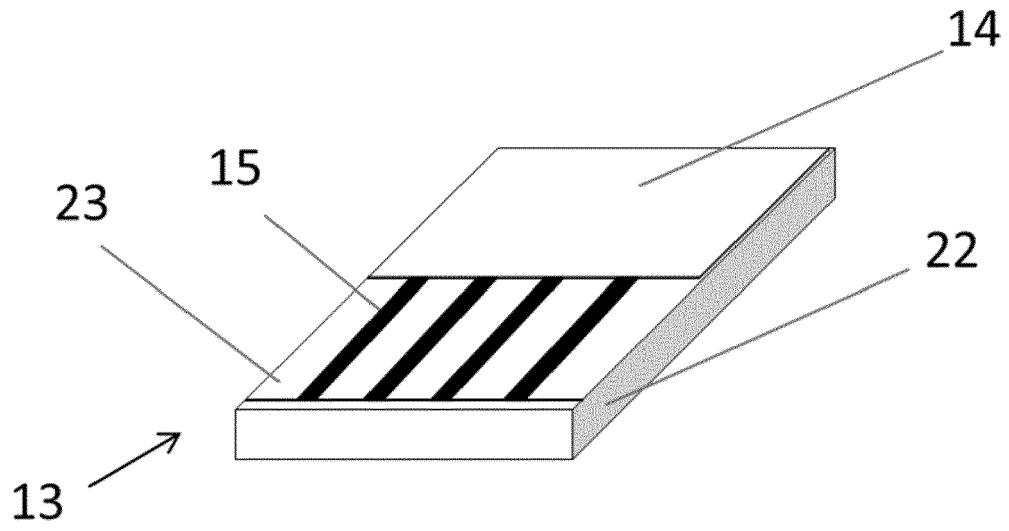
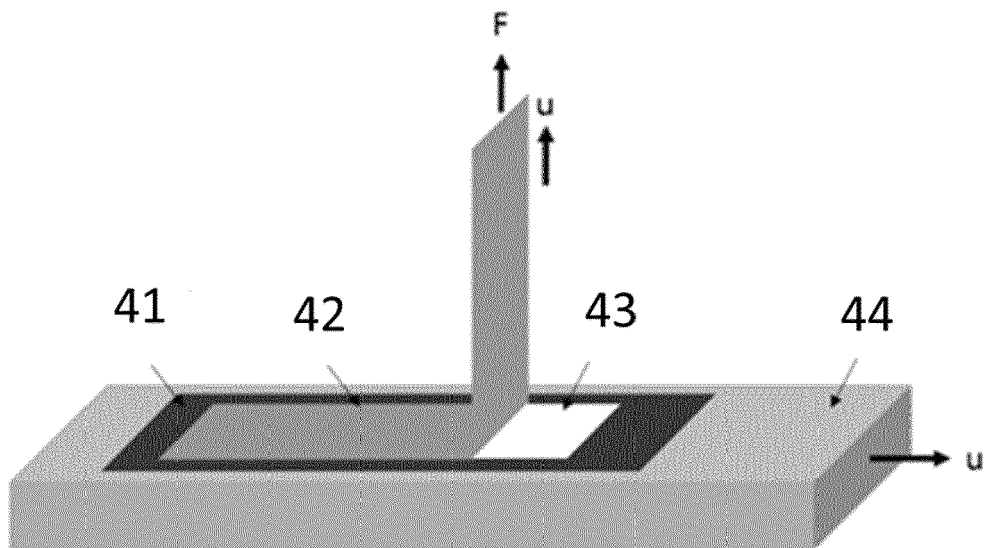

Fig 4





EUROPEAN SEARCH REPORT

Application Number  
EP 19 21 6433

5

10

15

20

25

30

35

40

45

50

55

DOCUMENTS CONSIDERED TO BE RELEVANT			
Category	Citation of document with indication, where appropriate, of relevant passages	Relevant to claim	CLASSIFICATION OF THE APPLICATION (IPC)
X	DE 197 52 819 A1 (ROCKWOOL MINERALWOLLE [DE]) 10 June 1999 (1999-06-10)	1,5,6,9,10,12,13,15	INV. E04D3/35 E04D5/14 E04D11/02
Y	* column 3, line 49 - column 4, line 64; figures 1-3 *	1-15	
Y	----- GB 2 552 985 A (KNAUF INSULATION SPRL [BE]) 21 February 2018 (2018-02-21) * paragraphs [0009], [0012], [0013], [0014], [0015], [0016], [0017], [0021], [0022]; figures 1-2 *	1-15	
X	WO 2013/098866 A1 (GEN MEMBRANE S P A [IT]) 4 July 2013 (2013-07-04)	12,15	
Y	* figures 2-7 * * page 2, lines 18-21 * * page 3, lines 14-15 * * page 11, lines 6-12 * * page 12, lines 4-11 - lines 17-20 *	1-11,13,14	TECHNICAL FIELDS SEARCHED (IPC)  E04D E04C E04B
Y	----- WO 01/81771 A2 (VELCRO IND [NL]; TACHAUER ERNEST S [US] ET AL.) 1 November 2001 (2001-11-01) * figure 3 *	14	
The present search report has been drawn up for all claims			
Place of search <b>The Hague</b>		Date of completion of the search <b>3 March 2020</b>	Examiner <b>Leroux, Corentine</b>
CATEGORY OF CITED DOCUMENTS X : particularly relevant if taken alone Y : particularly relevant if combined with another document of the same category A : technological background O : non-written disclosure P : intermediate document T : theory or principle underlying the invention E : earlier patent document, but published on, or after the filing date D : document cited in the application L : document cited for other reasons ..... & : member of the same patent family, corresponding document			

EPO FORM 1503 03.02 (P04C01)

ANNEX TO THE EUROPEAN SEARCH REPORT  
ON EUROPEAN PATENT APPLICATION NO.

EP 19 21 6433

5 This annex lists the patent family members relating to the patent documents cited in the above-mentioned European search report.  
The members are as contained in the European Patent Office EDP file on  
The European Patent Office is in no way liable for these particulars which are merely given for the purpose of information.

03-03-2020

Patent document cited in search report	Publication date	Patent family member(s)	Publication date
DE 19752819 A1	10-06-1999	NONE	
GB 2552985 A	21-02-2018	EP 3341193 A1 GB 2552985 A WO 2018033558 A1	04-07-2018 21-02-2018 22-02-2018
WO 2013098866 A1	04-07-2013	NONE	
WO 0181771 A2	01-11-2001	AU 5739101 A CA 2407516 A1 CN 1430708 A EP 1278964 A2 JP 2003531981 A MX PA02010638 A WO 0181771 A2	07-11-2001 01-11-2001 16-07-2003 29-01-2003 28-10-2003 14-05-2003 01-11-2001