



(11) **EP 3 674 489 B1**

(12) **EUROPEAN PATENT SPECIFICATION**

(45) Date of publication and mention of the grant of the patent:
26.07.2023 Bulletin 2023/30

(21) Application number: **19217178.3**

(22) Date of filing: **17.12.2019**

(51) International Patent Classification (IPC):
E03C 1/042^(2006.01) E03C 1/02^(2006.01)

(52) Cooperative Patent Classification (CPC):
E03C 1/023; E03C 1/042; E03C 2201/30

(54) **THERMOSTATIC FITTING**

THERMOSTATARMATUR

RACCORD THERMOSTATIQUE

(84) Designated Contracting States:
AL AT BE BG CH CY CZ DE DK EE ES FI FR GB GR HR HU IE IS IT LI LT LU LV MC MK MT NL NO PL PT RO RS SE SI SK SM TR

(30) Priority: **26.12.2018 ES 201831280**

(43) Date of publication of application:
01.07.2020 Bulletin 2020/27

(73) Proprietor: **Griferias Grober, S.L.**
50197 Zaragoza (ES)

(72) Inventor: **Ladrón Jiménez, Roberto**
50197 Zaragoza (ES)

(74) Representative: **Schäfer, Matthias W.**
Patentanwalt
Schwannseestrasse 43
81549 München (DE)

(56) References cited:
EP-A1- 2 508 683 BE-A- 629 630
DE-U1- 20 115 533 US-A1- 2010 176 328

EP 3 674 489 B1

Note: Within nine months of the publication of the mention of the grant of the European patent in the European Patent Bulletin, any person may give notice to the European Patent Office of opposition to that patent, in accordance with the Implementing Regulations. Notice of opposition shall not be deemed to have been filed until the opposition fee has been paid. (Art. 99(1) European Patent Convention).

Description

Object of the invention

[0001] The present invention refers to a thermostatic fitting for bath/shower that comprises three separate modules, intake module, mixing module and distribution module, connected to each other via piping sectors to distribute mixed water towards at least two outlets, with the particularity that this thermostatic fitting is presented in a container that acts as packaging, allowing very easy embedded mounting in the wall, in a horizontal or vertical position, given that the masonry opening is reduced considerably, and the packaging is another of the construction elements.

[0002] Once the container is embedded, the thermostatic fitting easily remains flush and level with the wall, which makes it possible, given that the modules are separate, for the front of the container to be tiled, with a decorative covering in between the modules, providing a very different aesthetic and practical option that has not been possible hitherto, as trim plates of a considerable size have had to be used to conceal the masonry opening.

[0003] The different modules are concealed by inserting the corresponding caps and knobs which fit snugly on the decorative or tiled surface.

Background of the invention

[0004] In the state of the art embedded thermostatic fittings are known, being configured by a casing in which all of the tap elements are integrated, forming a main central block that includes the mixer together with the check valves and the filters, causing a series of drawbacks such as, for example, a masonry opening that necessarily has to be hidden by fitting trim plates of a considerable size to conceal the masonry opening.

[0005] Another drawback is the limited accessibility for maintenance or repair of check valves and filters.

[0006] In the quest for other solutions, patent ES2524022 presents a perfected unit for dispensing mixed water in which the said unit is partially embedded in the wall, being connected to the exterior part via telescopic sections, forming a two-knob unit, technically far-removed from a thermostatic fitting.

[0007] EP 2 508 683 A1 discloses a thermostatic fitting according to the preamble of independent claim 1.

Description of the invention

[0008] The bath/shower thermostatic fitting for embedding seeks to eliminate the aforementioned problems by means of a modular configuration that permits diverse embodiments, to distribute mixed water towards at least two outlets.

[0009] According to the invention, the thermostatic fitting is configured to distribute mixed water towards a shower column/head or towards a shower hose and com-

prises three separate modules, an intake module, a mixing module and a distribution module, connected with each other via piping sectors which, in addition to maintaining the connection between the modules, brace the structure of the thermostatic fitting, the said thermostatic fitting being inserted in a container, which, in addition to acting as packaging, serves to facilitate joint embedded installation in a considerably reduced masonry opening.

[0010] The intake module comprises a casing with an inlet connection for cold water and another inlet connection for hot water, including inside it, check valves with filter, an outlet chamber for cold water, an outlet chamber for hot water and an inlet chamber for mixed water, the said chamber being connected, with a conduit positioned on the front of the said intake module. The inlet chamber for mixed water is not used in this embodiment and therefore remains sealed with a plug, so the conduit located on the front of the intake module remains unused, as it is not utilised in this embodiment.

[0011] The intake module incorporates, on its upper part, an insertion coupling envisaged for attaching a covering cap that conceals and protects the check valves with filter.

[0012] It is important to note the different possible options that the configuration of the intake module offers, since the inlet chamber for mixed water can be enabled in any other alternative embodiment, allowing a different combination with the other modules included in the thermostatic fitting.

[0013] A characteristic of the invention is the separation of the check valves with filter from the thermostatic mixer cartridge, this way configuring, a separate module to contain the check valves and their corresponding filters, with the advantage that it permits access to them, for cleaning or replacement, by simply removing the covering cap, which is fixed and does not have actuating functions, although it does have piping functions in an alternative embodiment.

[0014] The mixing module comprises a casing that includes, inside it, a thermostatic mixer cartridge and other functional elements intended to regulate the temperature of the water; the said casing includes a cold water inlet chamber, a hot water inlet chamber and a mixed water outlet chamber and, on its lower part, a through hole.

[0015] The through hole is intended for attaching a piping sector used in an alternative embodiment.

[0016] The mixing module incorporates, on its upper part, an insert coupling for the attachment of a control knob intended for water temperature control. The said control knob incorporates a temperature indicating scale supplement, or optimal usage temperature indicator, since it can be rotated so as to position it at the point of comfort point of the user's choice.

[0017] The mixing module is of a small size, similar to the adjacent modules, thanks to the check valves with filter being separate; it is characteristic of the invention that the said elements are incorporated in a separate module, in this case, the intake module.

[0018] The distribution module comprises a casing configured with at least two outlet connections to divert the mixed water towards the shower column/head or towards a bath or shower hose, the said casing comprising an inlet chamber for mixed water.

[0019] The casing of the distribution module also comprises a chamber that is envisaged for the return of mixed water and an evacuation conduit positioned on the front of the said module, which, in this preferred embodiment, are sealed by insertion of a plug, ready to be used in other alternative embodiments.

[0020] The distribution module includes, on its upper part, an insert coupling to attach an actuating knob intended to divert the mixed water towards the shower column/head or towards a bath or a shower hose, simultaneously controlling the water flow by the gradual actuation of the actuating knob.

[0021] In a preferred embodiment, watertight connection between the intake, mixing and distribution modules is carried out via the following piping sectors:

Cold water piping sector, that connects the cold water outlet chamber of the intake module with the cold water inlet chamber of the mixing module.

[0022] Hot water piping sector, that connects the hot water outlet chamber of the intake module with the hot water inlet chamber of the mixing module.

[0023] Mixed water piping sector, that connects the mixed water outlet chamber of the mixing module with the mixed water inlet chamber of the distribution module.

[0024] The special configuration of the thermostatic fitting modules is characteristic of the invention as they comprise different chambers intended for inlet and outlet of cold, hot and mixed water, with the aim of being able to configure different embodiments when combining them.

[0025] The container, that acts as packaging, is made of a very strong, lightweight material and includes cavities intended for positioning the three modules, connected to each other via their different piping sectors, and a front finish, coinciding with the cap and knobs of the aforementioned thermostatic fitting, which allows it to be tiled over.

[0026] Thus, the container is a constructive unit that considerably facilitates the embedded mounting of the thermostatic fitting which, thanks to the reduction in the masonry opening, eliminates the use of large trim plates, since only the cap and the knobs of the different modules are necessary.

[0027] Once the container is embedded, the thermostatic fitting easily remains flush and level with the wall, which makes it possible, given that the modules are separate, for the front of the container to be tiled, with a decorative covering in between the modules, providing a very different aesthetic and practical option that has not been possible hitherto, as trim plates of a considerable size have had to be used to conceal the masonry opening.

[0028] After the front of the container has been covered or tiled, the insertion couplings of the modules, envisaged

for the attachment of the corresponding caps and knobs, remain visible, with the particularity that an intermediate element has been envisaged for insertion between them, allowing to adjust for or to absorb possible construction gaps between the thermostatic fitting and the mortar plus tile; in this way both the caps and the knobs fit snugly on the tile surface or decorative covering.

[0029] It is important to point out that the packaging is used as another constructive element, avoiding the generation of waste, to the benefit of the environment.

[0030] In an alternative embodiment the thermostatic fitting is configured to distribute mixed water towards a shower column/head or towards a shower hose, positioned in this case, on the covering cap of the intake module, and comprising a modular structure similar to the preferred embodiment but suitable for an additional function.

[0031] In this alternative embodiment the inlet chamber for mixed water of the intake module is enabled by removing the sealing plug and inserting a connecting tube in the conduit positioned on the front of the said module.

[0032] The intake module incorporates a covering cap that, in addition to concealing and protecting the check valves with filter, comprises an attachment support for the attachment of the handle of a shower hose and the corresponding water intake connection, the said intake connection being connected to the connecting tube to divert the water towards the shower hose, incorporated in the said covering cap.

[0033] Two outlets are used on the distribution module, one to divert the mixed water towards a shower column/head via its corresponding outlet connections and another outlet to divert the mixed water towards a shower hose, situated on the covering cap of the intake module, in this case by enabling the mixed water return chamber, by removing the sealing plug.

[0034] In this alternative embodiment the line corresponding to the outlet connection to divert the mixed water towards the bath is sealed by means of a plug.

[0035] The actuating knob of the distribution module diverts the mixed water towards the shower column/head or towards a shower hose situated on the covering cap of the intake module, simultaneously controlling the water flow by gradual actuation of the knob.

[0036] The watertight connection of the piping sectors, between the intake, mixing and distribution modules, is the same as that described in the preferred embodiment and also incorporates a mixed water return piping sector which connects the mixed water return chamber of the distribution module to the mixed water inlet chamber of the intake module, the mixed water return piping sector fitting snugly in the through hole of the mixing module.

[0037] It is important to note that, via the mixed water return piping, the mixed water is distributed for its use in an additional shower hose.

[0038] In another alternative embodiment, the thermostatic fitting is configured with three outlets to distribute

the mixed water towards a shower column/head or towards a bath or towards a shower hose, positioned at a certain distance from the thermostatic fitting, comprising a modular structure similar to the preferred embodiment but suitable for an additional function.

[0039] In this alternative embodiment, the distribution module is configured with three outlet connections, one for each function, to distribute the mixed water towards the shower column/head or towards a bath or towards a shower hose, located at a certain distance from the thermostatic fitting, depending on the construction configuration of the bath.

[0040] In this alternative embodiment, the chamber envisaged for the return of mixed water and an evacuation conduit, positioned on the front of the said module, are sealed by insertion of a plug, ready to be used in other alternative embodiments.

[0041] Likewise, the mixed water inlet chamber of the intake module is also sealed by means of a plug as it is not used in this alternative embodiment.

[0042] The watertight connection of the piping sectors, between the intake module, mixing module and distribution module is exactly the same as that described in the preferred embodiment.

[0043] In another alternative embodiment the thermostatic fitting is configured to distribute the mixed water towards a shower column/head or towards a shower hose, positioned in this case, on the covering cap of the intake module, comprising a modular structure similar to the previous alternative embodiment, but suitable for an additional function.

[0044] In this alternative embodiment the inlet chamber for mixed water of the intake module is enabled by removing the sealing plug and inserting a connecting tube in the conduit positioned on the front of the said module.

[0045] The intake module incorporates a covering cap that, in addition to concealing and protecting the check valves with filter, comprises an attachment support for the attachment of the handle of a shower hose and the corresponding water inlet connection, the said inlet connection being connected to the connecting tube to divert the water towards the shower hose, incorporated in the said covering cap.

[0046] The distribution module is configured with three outlet connections, one to divert the mixed water towards a shower column/head, another to divert the water towards a bath, while the outlet connection to divert the mixed water towards a shower hose or bath remains sealed by means of a plug.

[0047] In this alternative embodiment the mixed water return chamber is enabled by removing the sealing plug to divert the mixed water towards a shower hose, positioned on the covering cap of the intake module.

[0048] The actuating knob of the distribution module diverts the mixed water towards the shower column/head or towards a bath or towards the shower hose positioned on the covering cap of the intake module, simultaneously

controlling the water flow by gradual actuation of the knob.

[0049] The watertight connection of the piping sectors, between the intake, mixing and distribution modules, is the same as that described in the preferred embodiment and also incorporates a mixed water return piping sector which connects the mixed water return chamber of the distribution module to the mixed water inlet chamber of the intake module, the mixed water return piping sector fitting snugly in the through hole of the mixing module.

[0050] It is important to note that, via the mixed water return piping, the mixed water is distributed for its use in an additional shower hose.

[0051] In another alternative embodiment, a drain device is incorporated, which comprises a drainage line, also incorporating a connecting tube, the said device being positioned between the distribution module, in any of the described embodiments, and the actuating knob.

[0052] The evacuation conduit of the distribution module is enabled in this embodiment by removing the sealing plug, for the insertion of the connecting tube supplied in the drain device, the evacuation conduit of the distribution module being connected to the drainage line to the exterior, of the drain device, allowing drainage of water retained in the shower column/head to the exterior, by means of the closed positioning of the actuating knob of the distribution module.

[0053] Although orifices or pipes especially intended for draining water retained in water piping are already known in the state of the art, in this the invention an innovative separate drain supplement is advocated, which is optionally included in a thermostatic fitting of an embedded nature.

[0054] In another alternative embodiment the structure of the thermostatic fitting is reinforced by means of longitudinal securing ties that pass through the intake, mixing and distribution modules, bracing the unit, the ends of the said ties being secured by locking means.

[0055] It is important to highlight the function of the said ties, which, together with the piping sectors strengthen the structure of the thermostatic fitting, in any of the described embodiments.

Advantages of the invention

[0056] This thermostatic fitting for embedding that is presented affords numerous advantages over those currently available, the main advantage being that it is configured with three separate modules, the intake module, mixing module and distribution module, connected to each other via piping sectors, inserted in a container which, in addition to being used as packaging, facilitates the execution of embedding the thermostatic fitting.

[0057] An important added advantage is that once the thermostatic fitting is embedded in the masonry opening, it easily remains flush and level with the wall, making it possible, given that the modules are separate, for the front of the container to be tiled, with decorative covering

in between the modules, providing a very different aesthetic and practical option that has not been possible hitherto, as trim plates of a considerable size have had to be used until now.

[0058] An important advantage, as a result of the previous one, is that once the covering or tiling over the front of the container has been carried out, the module couplings, intended for the insertion of the corresponding caps and knobs, remain visible, with the particularity that the insertion of an intermediate element between them has been envisaged, allowing to adjust for possible construction gaps between the thermostatic fitting and the mortar plus tile.

[0059] Another important advantage is that the check valves with filter are separate from the thermostatic mixing cartridge, being integrated in an intake module, thus allowing the dimensions of the different modules to be reduced to facilitate their embedded installation, this way reducing the masonry opening.

[0060] Another advantage arises as a consequence of the reduction of the masonry opening, which allows the elimination of the trim plates that are commonly used in this type of mounting, replacing them with the covering cap and knobs of the different modules.

[0061] An added advantage is that, in an alternative embodiment, the thermostatic fitting incorporates and additional connection for a shower hose, positioned on the fitting itself or separate from it.

[0062] A further added advantage is the possibility of incorporating a drain supplement on the thermostatic fitting.

[0063] And finally, an added advantage is that, in addition to the piping sectors that maintain the structural stiffness of the thermostatic fitting, the said structure is reinforced by incorporating longitudinal ties.

Description of the figures

[0064] To provide a better understanding of this addition, a preferred practical embodiment is shown in the drawing attached.

Figure -1- shows a perspective view of the thermostatic fitting for bath/shower, housed in a container, for embedding, in a preferred embodiment.

Figures -2 and 3- show a perspective view of the different modules integrated in the thermostatic fitting, connected to each other, in a preferred embodiment.

Figure -4- shows a perspective view of the container.

Figure -5- shows an installation diagram of the thermostatic fitting in a horizontal position, in a preferred embodiment.

Figure -6- shows an installation diagram of the ther-

mostatic fitting in a vertical position, in a preferred embodiment.

Figure -7- shows a perspective view of the thermostatic fitting for bath/shower housed in a container, for embedding, in an alternative embodiment.

Figure -8- shows a perspective view of the different modules integrated in the thermostatic fitting, connected to each other, in an alternative embodiment.

Figure -9- shows an installation diagram of the thermostatic fitting in a horizontal position, in an alternative embodiment.

Figure -10- shows a perspective view of the thermostatic fitting for bath/shower housed in a container, to be embedded, in an alternative embodiment.

Figure -11- shows a perspective view of the different modules integrated in the thermostatic fitting, connected to each other, in an alternative embodiment.

Figure -12- shows an installation diagram of the thermostatic fitting in a horizontal position, in an alternative embodiment.

Figure -13- shows a perspective view of the thermostatic fitting for bath/shower housed in a container, for embedding, in an alternative embodiment.

Figure -14- shows a perspective view of the different modules integrated in the thermostatic fitting, connected to each other, in an alternative embodiment.

Figure -15- shows an installation diagram of the thermostatic fitting in a horizontal position, in an alternative embodiment.

Figures -16 and 17 - show a perspective view of the coupling of a drain device in any other the embodiments carried out.

Preferred embodiment of the invention

[0065] The conformation and characteristics of the invention can be better understood in the following description that relates to the attached figures.

[0066] Figure 1 shows the thermostatic fitting (1) in a preferred embodiment, configured with two outlets to distribute the mixed water towards a shower column/head (2) or towards a shower hose (4).

[0067] The thermostatic fitting (1) is shown housed in a container (8) which in turn acts as packaging and as a construction element since the embedded installation of the thermostatic fitting (1) is carried out jointly with the said container (8).

[0068] The covering cap (14) for attaching on the intake

module (5) is shown, as is the control knob (16) with the temperature indicating scale supplement (17) or optimal usage temperature indicator, for attaching on the mixing module (6) and the actuating knob (21) for attach on the distributing module (7), controlling the water flow gradually, the said knobs and cap being secured onto the said controls by an insertion coupling (13) integrated in the said modules.

[0069] The container (8), given that it remains flush with the wall, makes it possible, since that the intake module (5), mixing module (6) and distribution module (7) are separate, as shown in figure 1, for the front of the container (8) to be tiled, with a decorative covering between the modules, providing a very different aesthetic and practical option that has not been possible hitherto, as until now trim plates of a considerable size have had to be used.

[0070] Figure 2 shows the modular structure of the thermostatic fitting (1), showing the separate intake module (5), the mixing module (6) and the distribution module (7), connected to each other via piping sectors, also showing securing longitudinal ties (32) that, by passing through the intake (5), mixing (6) and distribution (7) modules, brace the unit, the ends of the said ties being secured by locking means (33).

[0071] The intake module (5) is shown, which comprises a casing with two inlets, one for cold water (9) and another for hot water (10), including inside it the check valves (11) with filter, incorporating on its upper part two outlet piping sectors, one for cold water (22) and, very close by and parallelly positioned, another for hot water (23), being connected to the mixing module (6) by watertight connecting means.

[0072] The intake module comprises a casing with an inlet connection for cold water (9) and another inlet connection for hot water (10), including inside it, the check valves (11) with filter, an outlet chamber for cold water, an outlet chamber for hot water and an inlet chamber for mixed water (not shown), the said chamber being connected, with a conduit (12) positioned on the front of the said intake module (5).

[0073] The intake module (5) contains the check valves (11) and their corresponding filters, with the advantage that they can be accessed for cleaning or replacement by simply removing the covering cap (14), which is fixed and does not have actuating functions.

[0074] The mixing module (6) comprises a casing that includes, inside it, a thermostatic mixer cartridge and other functional elements (not shown) intended to regulate the temperature of the water; the said casing includes a cold water inlet chamber, a hot water inlet chamber and a mixed water outlet chamber (not shown) and, on its lower part, a through hole (15).

[0075] The mixing module (6) is configured in a small size, similar to the adjacent modules, thanks to the separation of the check valves (11) with filter, since it is a characteristic of the invention that the said elements are incorporated in a separate module, in this case, in the

intake module (5).

[0076] The distribution module (7) is illustrated, showing a casing configured with at least two outlet connections (18) to divert the mixed water towards the shower column/head (2) or towards a bath (3) or shower hose (4), the said casing comprising an inlet chamber for mixed water (not shown).

[0077] The casing of the distribution module (7) also comprises a chamber that is envisaged for the return of the mixed water and an evacuation conduit (19), positioned on the front of the said module, which, in this preferred embodiment, are sealed by insertion of a plug (20), ready to be used in other alternative embodiments.

[0078] The watertight connection between the intake (5), mixing (6) and distribution (7) modules, shown in figures 1, 2 and 3, is carried out via the following piping sectors:

Cold water piping sector (22), that connects the cold water outlet chamber of the intake module (5) with the cold water inlet chamber of the mixing module (6).

[0079] Hot water piping sector (23), that connects the hot water outlet chamber of the intake module (5) with the hot water inlet chamber of the mixing module (6).

[0080] Mixed water piping sector (24), that connects the mixed water outlet chamber of the mixing module (6) with the mixed water inlet chamber of the distribution module (7).

[0081] Figure 3 shows the connection between the different modules, viewed from the rear, indicating the sealing of the mixed water return chamber, distribution module (7); the mixed water inlet chamber of the intake module (5) also being sealed in the same way, by means of plugs (20); the conduit (12) positioned on the front of the intake module (5), remaining unused as it is not utilised in this preferred embodiment.

[0082] Figure 4 shows the container (4) which acts as packaging, made of very strong, lightweight material, indicating the cavities (25) intended for the positioning of the thermostatic fitting, in any of its embodiments. Thus, the container (4) is a constructive unit that considerably facilitates the embedded mounting of the thermostatic fitting, which thanks to its reduced dimensions, adjusted to the size of the fitting, considerably decreases the masonry opening, eliminating the use of trim plates, since only the covering caps (14 or 14.1) and the knobs (16 and 21) of the different modules are necessary.

[0083] Figure 5 schematically illustrates the installation of the thermostatic fitting (1) in a horizontal position, in a preferred embodiment in which the mixed water is diverted towards a shower column/head (2) or towards a shower hose (4), showing the inlet of cold water and hot water through the intake module (5), the inlet of hot water and cold water in the mixing module, via the cold water piping sector (22) and hot water piping sector (23), the mixed water passing towards the distribution module (7) via the mixed water piping sector (24), for its distribution, depending on the position of the actuating knob (21)

[0084] Figure 6 schematically illustrates the installation

of the thermostatic fitting (1) in a vertical position, in a preferred embodiment in which the mixed water is diverted towards a shower column/head (2) or towards a shower hose (4), showing the inlet of cold water and hot water through the intake module (5), the inlet of hot water and cold water in the mixing module, via the cold water piping sector (22) and hot water piping sector (23), the mixed water passing towards the distribution module (7) via the mixed water piping sector (24), for its distribution, depending on the position of the actuating knob (21)

[0085] Figures 7 and 8 illustrate the thermostatic fitting (1.1) in an alternative embodiment, configured to distribute the mixed water towards a shower column/head (2) or towards a shower hose (4), positioned in this case, on the covering cap (14.1) of the intake module, comprising a modular structure similar to the preferred embodiment, but suitable for an additional function.

[0086] In this alternative embodiment the inlet chamber for mixed water of the intake module (5) is enabled by removing the sealing plug (20) and inserting a connecting tube (26) in the conduit (12) positioned on the front of the said module.

[0087] The intake module (5) is shown, which incorporates a covering cap (14.1) which, in addition to concealing and protecting the check valves (11) with filter, comprises an attachment support (30) for the attachment of the handle of a shower hose and the corresponding water inlet connection (31), the said inlet connection (31) being connected with the connecting tube (26) to divert the water towards the shower hose (4), incorporated in the said covering cap (14.1).

[0088] Figure 8 shows the distribution module (7) using two outlets, one to divert the mixed water towards a shower column/head (2), via its corresponding outlet connection (18), and another outlet to divert the mixed water towards a shower hose (4), positioned on the covering cap (14.1) of the intake module (5), in this case the mixed water return chamber (not shown) is enabled by removing the sealing plug (20), showing the outlet connection (18) to divert the mixed water towards the bath (3), sealed by a plug (20) since it is not utilised in this alternative embodiment.

[0089] The actuating knob (21) of the distribution module (7) is shown, being intended to divert the mixed water towards the shower hose (4) or towards the shower column/head (2), simultaneously controlling the water flow, since the gradual actuation of the actuating knob (11) allows the control of the said flow.

[0090] Furthermore, figures 7 and 8 show common elements such as, the container (8) of the mixing module (6), with its corresponding control knob (16) and temperature scale supplement (17), the outlet piping sectors, one for cold water (22) and the other for hot water (23), the mixed water inlet piping sector (24), also showing the longitudinal ties (32) for securing.

[0091] This alternative embodiment shows the incorporation of a mixed water return piping sector (27) that connects the mixed water return chamber of the distri-

bution module (7) with the mixed water inlet chamber of the intake module (5), the mixed water return piping sector (27) fitting snugly in the through hole (15) of the mixing module (6).

[0092] Figure 9 schematically illustrates the installation of the thermostatic fitting (1.1) in a horizontal position, in an alternative embodiment in which the mixed water is diverted towards a shower column/head (2) or towards a shower hose (4), positioned on the water intake module (5), showing the inlet of cold water and hot water through the intake module (5), the inlet of hot water and cold water in the mixing module, via the cold water piping sector (22) and hot water piping sector (23), the mixed water passing towards the distribution module (7) via the mixed water piping sector (24), using, in this case, the mixed water return piping (27) towards the shower hose (4) for its distribution, depending on the position of the actuating knob (21)

[0093] Figures 10 and 11 illustrate the thermostatic fitting (1.2) in an alternative embodiment, configured with three outlets to distribute the mixed water towards a shower column/head (2) or towards a bath (3) or towards a shower hose (4), positioned at a certain distance from the thermostatic fitting (1.2), comprising a modular structure similar to the preferred embodiment, but suitable for an additional function.

[0094] The distribution module (7) is shown, configured with three outlet connections (18), one for each function, to distribute the mixed water towards the shower column/head (2) or towards a bath (3) or towards a shower hose (4), located at a certain distance from the thermostatic fitting (1.2).

[0095] In this alternative embodiment, the chamber envisaged for the return of mixed water (not shown) and an evacuation conduit (19), positioned on the front of the said module, are sealed by the insertion of a plug (20), ready to be used in other alternative embodiments, the mixed water inlet chamber (not shown) of the intake module (5) remaining sealed by means of a plug (20).

[0096] The watertight connection of the piping sectors (22, 23 and 24), between the intake module (5), mixing module (6) and distribution module (7) is exactly the same as that described in the preferred embodiment, shown in figure 1.

[0097] Furthermore, figures 10 and 11 show common elements such as, the container (8), the mixing module (6) with its corresponding control knob (16) and temperature scale supplement (17), the outlet piping sectors, one for cold water (22) and the other for hot water (23), the mixed water inlet piping sector (24), also showing the longitudinal ties (32) for securing.

[0098] Figure 12 schematically illustrates the installation of the thermostatic fitting (1.2) in a horizontal position, in an alternative embodiment in which the mixed water is diverted towards a shower column/head (2) or towards a bath (3) or towards a shower hose (4), positioned at a certain distance from the thermostatic fitting (1.2), showing the inlet of cold water and hot water through the intake

module (5), the inlet of hot water and cold water in the mixing module, via the cold water piping sector (22) and hot water piping sector (23), the mixed water passing towards the distribution module (7) via the mixed water piping sector (24), for its distribution depending on the position of the actuating knob (21).

[0099] Figures 13 and 14 illustrate the thermostatic fitting (1.3) in an alternative embodiment, configured to distribute the mixed water towards a shower column/head (2) or towards a bath (3) or towards a shower hose (4), positioned in this case, on the covering cap (14.1) of the intake module (5), comprising a modular structure similar to the preferred embodiment shown in figures 10 and 11, but suitable for an additional function.

[0100] In this alternative embodiment the inlet chamber for mixed water (not shown) of the intake module (5) is enabled by removing the sealing plug (20) and inserting a connecting tube (26) in the conduit (12) positioned on the front of the said module.

[0101] The intake module (5) is shown, incorporating a covering cap (14.1) which, in addition to concealing and protecting the check valves (11) with filter, comprises an attachment support (30) for the attachment of the handle of a shower hose and the corresponding water inlet connection (31), the said inlet connection (31) being connected to the connecting tube (26) to divert the water towards the shower hose (4), incorporated in the said covering cap (14.1).

[0102] The distribution module (7) is shown, configured with three outlet connections (18), one to divert the mixed water towards a shower column/head (2), another to divert the water towards a bath (3), while the outlet connection to divert the mixed water towards a shower hose (4) remains sealed by means of a plug (20).

[0103] In this alternative embodiment the mixed water return chamber (not shown) of the distribution module (7) is enabled by removing the sealing plug (20), to divert the mixed water towards a shower hose (4), positioned on the covering cap (14.1) of the intake module (5).

[0104] This alternative embodiment shows the incorporation of a mixed water return piping sector (27) that connects the mixed water return chamber of the distribution module (7) with the mixed water inlet chamber of the intake module (5), the mixed water return piping sector (27) fitting snugly in the through hole (15) of the mixing module (6).

[0105] Furthermore, figures 13 and 14 show common elements such as, the container (8) the mixing module (6), with its corresponding control knob (16) and temperature scale supplement (17), the outlet piping sectors, one for cold water (22) and the other for hot water (23), the mixed water inlet piping sector (24), also showing the longitudinal ties (32) for securing.

[0106] Figure 15 schematically illustrates the installation of the thermostatic fitting (1.3) in a horizontal position, in an alternative embodiment in which the mixed water is diverted towards a shower column/head (2) or towards a bath (3) or towards a shower hose (4), positioned on

the water intake module (5), showing the inlet of cold water and hot water through the intake module (5), the inlet of hot water and cold water in the mixing module, via the cold water piping sector (22) and hot water piping sector (23), the mixed water passing towards the distribution module (7) via the mixed water piping sector (24), using, in this case, the mixed water return piping (27) towards the shower hose (4) for its distribution depending on the position of the actuating knob (21).

[0107] Figures 16 and 17 show the incorporation of a drain device (28), indicating a drainage line (29), incorporating in addition a connecting tube (26), the said device being positioned between the distribution module (7), in any of the described embodiments of the thermostatic fitting (1 - 1.1. - 1.2 or 1.3) and the actuating knob (21).

[0108] The evacuation conduit (19) of the distribution module (7) is enabled by removing the sealing plug (20), for insertion of the connecting tube (26) supplied in the drain device (28), the connecting tube (26) being connected to of the drainage line (29) on the outside of the drain device (28), allowing drainage of water retained in the shower column/head (2) to the exterior, by the closed positioning of the actuating knob of the distribution module (7).

[0109] The longitudinal ties (32) shown in figures 2, 3, 8, 11 and 14 are used optionally as a structural reinforcement in any of the described embodiments of the thermostatic fitting.

[0110] A person skilled in the art will easily comprehend that the characteristics of different embodiments can be combined with the characteristics of other possible embodiments, provided that the combination is technically possible and falls under the scope of invention as defined in the appended claims.

Number list of components

[0111]

1	Thermostatic fitting
1.1	Thermostatic fitting
1.2	Thermostatic fitting
1.3	Thermostatic fitting
2	Shower column/head
3	Bath
4	Shower hose
5	Intake module
6	Mixing module
7	Distribution Module
8	Container
9	Inlet connection for cold water
10	Inlet connection for hot water
11	Check valves
12	Conduit
13	Insertion coupling
14	Covering cap
14.1	Covering cap

15	Through hole
16	Control knob
17	Supplement
18	Outlet connection
19	Evacuation conduit
20	Plug
21	Actuating knob
22	Cold water piping sector
23	Hot water piping sector
24	Mixed water piping sector
25	Cavities
26	Connecting tube
27	Mixed water return piping sector
28	Drain device
29	Drainage line
30	Attachment support
31	Inlet connection
32	Longitudinal ties
33	Locking means

Claims

1. - Thermostatic fitting comprising three separate modules,
- intake module (5)
 - mixing module (6) and
 - distribution module (7) with at least two outlet connections (18), to divert the mixed water towards a shower column/head (2), or towards a bath (3) or towards a shower hose (4), the said modules being connected to each other through piping sectors (22 - 23 - 24 and/or 27), **characterised in that**
 - the said thermostatic fitting (1 - 1.1 - 1.2 or 1.3) is inserted in a container (8) used as packaging, envisaged for joint embedded installation in a horizontal or vertical position,
 - remaining concealed
 - the intake module (5) by the attachment of a covering cap (14, 14.1)
 - the mixing module (6) by the attachment of a control knob (16) with a temperature indicating scale supplement (17) or optimal usage temperature indicator,
 - the distribution module (7) by the attachment an actuating knob (21) to divert the mixed water towards a shower column/head (2) or towards a bath (3), or towards a shower hose (4).
2. - Thermostatic fitting, according to claim 1, **wherein** the thermostatic fitting (1) distributes the mixed water towards a shower column/head (2) or towards a shower hose (4), via the intake module (5), the mixing module (6) and the distribution module (7) configured
- with two outlet connections (18).
3. - Thermostatic fitting, according to claim 1, **wherein** the thermostatic fitting (1.1), in an alternative embodiment, distributes the mixed water towards a shower column/head (2) or towards a shower hose (4) positioned on the covering cap (14.1) of the thermostatic fitting (1.1), via the intake module (5), the mixing module (6) and the distribution module (7) configured with two outlet connections (18), the said covering cap (14.1) comprising an attachment support (30) for a shower handle and an inlet connection (31) for the shower hose (4).
4. - Thermostatic fitting, according to claim 1, **wherein** the thermostatic fitting (1.2), in an alternative embodiment, distributes the mixed water towards a shower column/head (2) or towards a bath (3) or towards a shower hose (4) positioned at a distance from the thermostatic fitting (1.2), via the intake module (5), the mixing module (6) and the distribution module (7) configured with three outlet connections (18).
5. - Thermostatic fitting, according to claim 1, **wherein** the thermostatic fitting (1.3), in an alternative embodiment, distributes the mixed water towards a shower column/head (2) or towards a bath (3) or towards a shower hose (4) positioned on the covering cap (14.1) of the thermostatic fitting (1.3), via the intake module (5), the mixing module (6) and the distribution module (7) configured with two outlet connections (18), one of the outlet connections (18) being sealed by means of a sealing plug (20), the said covering cap (14.1) comprising an attachment support (30) for a shower handle and an inlet connection (31) for the shower hose (4).
6. - Thermostatic fitting, according to any of the claims 1 to 5, **wherein** the intake module (5), comprises a casing that incorporates, on its upper part, an insertion coupling (13), an inlet connection for cold water (9) and another inlet connection for hot water (10), including inside it
 - the check valves (11) with filter
 - an outlet chamber for cold water
 - an outlet chamber for hot water, and
 - an inlet chamber for mixed water, sealed by means of a plug (20) when not used, the said chamber being connected to a conduit (12) positioned on the front of the intake module (5).
7. - Thermostatic fitting, according to claims 1, 3 and 5, **wherein** in the intake module (5), the inlet chamber for mixed water is enabled by removing the sealing plug (20), to divert the mixed water towards a shower hose (4) positioned on the covering cap

(14.1) of the thermostatic fitting (1.3), the conduit (12) positioned on the front of the said intake module (5) being enabled by inserting a connecting tube (26) connected to the water inlet connection (31) comprised in the covering cap (14.1).

8. - Thermostatic fitting, according to any of the claims 1 to 5, **wherein** the mixing module (6), comprises a casing that incorporates, on its upper part, an insertion coupling (13) and, on its lower part, a through hole (15) comprising inside it

- a mixing cartridge and other functional elements intended for water temperature regulation,
- a cold water inlet chamber,
- a hot water inlet chamber, and
- a mixed water outlet chamber.

9. - Thermostatic fitting, according to any of the claims 1 to 5 **wherein** the distribution module (7) comprises a casing with at least two outlet connections (18) to divert the mixed water through

- a mixed water inlet chamber, towards the shower column/head (2) or towards a bath (3) or towards a shower hose (4), and
- a mixed water return chamber, sealed by means of a plug (20), when not used.

Incorporating on its upper part, an insertion coupling (13) and an evacuation conduit (19) sealed by means of a plug (20), when not used.

10. - Thermostatic fitting, according to claims 1, 3, 5 and 9, **wherein** in the distribution module (7) the mixed water return chamber is enabled by removing the sealing plug (20), to divert the water towards a shower hose (4) positioned on the covering cap (14.1) of the thermostatic fitting (1.1 and 1.3).

11. - Thermostatic fitting, according to any of the preceding claims, **wherein** the watertight connection between the intake module (5), mixing module (6) and distribution module (7) is carried out through the following piping sectors:

- Cold water piping sector (22) that connects the cold water outlet chamber of the intake module (5) with the cold water inlet chamber of the mixing module (6).
- Hot water piping sector (23) that connects the hot water outlet chamber of the intake module (5) with the hot water inlet chamber of the mixing module (6).
- Mixed water piping sector (24) that connects the mixed water outlet chamber of the mixing module (6) with the mixed water inlet chamber

of the distribution module (7).

- Mixed water return piping sector (27) that connects the mixed water return chamber of the distribution module (7) with the mixed water inlet chamber of the intake module (5), the said mixed water return piping sector (27) being positioned in the through hole (15) of the mixing module (6).

12. - Thermostatic fitting, according to any of the preceding claims, **wherein** the container (8) is made of very strong, lightweight material, comprising cavities (25), intended for positioning the modules of the thermostatic fitting (1 - 1.1 - 1.2 or 1.3) and a front finish that allows tiling or a decorative surface over it, the cap (14 or 14.1) and knobs (16 and 21) of the aforementioned thermostatic fitting being inserted on its corresponding modules, remaining in position on the said surface.

13. - Thermostatic fitting, according to any of the preceding claims, **wherein** it incorporates, between the distribution module (7), in any of the described embodiments, and the actuating knob (21), a drain device (28) that comprises a drainage line (29) in contact with the exterior, also incorporating a connecting tube (26).

14. - Thermostatic fitting, according to claim 13, **wherein** in the distribution module (7) an evacuation conduit (19) is enabled for the insertion of the connecting tube (26) that connects the said evacuation conduit (19) with the drainage line (29) of the drain device (28).

15. - Thermostatic fitting, according to any of the preceding claims, **wherein** it incorporates, in any of the described embodiments of the thermostatic fitting (1 - 1.1 - 1.2 or 1.3), longitudinal ties (32) for securing, that by passing through the intake module (5), mixing module (6) and distribution module (7), reinforce the structure, the ends of the said longitudinal ties (32) being secured by locking means (33).

45 Patentansprüche

1. Thermostatarmatur, aufweisend drei separate Module,

- Einlassmodul (5)
- Mischmodul (6) und
- Verteilermodul (7) mit mindestens zwei Auslassanschlüssen (18), um das Mischwasser zu einer Duschsäule/einem Duschkopf (2) oder zu einer Badewanne (3) oder zu einem Duschschlauch (4) umzuleiten, wobei die Module über Rohrleitungsabschnitte (22, 23, 24 und/oder 27) miteinander verbunden sind,

dadurch gekennzeichnet, dass

- • die Thermostatarmatur (1, 1.1, 1.2 oder 1.3) in ein als Verpackung verwendetes Behältnis (8) eingesetzt ist, das für einen gemeinsamen eingebetteten Einbau in horizontaler oder vertikaler Position vorgesehen ist,
 - wobei verborgen bleiben
 - das Einlassmodul (5) durch die Anbringung einer Abdeckkappe (14, 14.1)
 - das Mischmodul (6) durch die Anbringung eines Einstellknopfs (16) mit einer Temperaturanzeigenskalenergänzung (17) oder einer Anzeige zur optimalen Gebrauchstemperatur,
 - das Verteilermodul (7) durch die Anbringung eines Betätigungsknopfs (21), um das Mischwasser zu einer Duschsäule/einem Duschkopf (2) oder zu einer Badewanne (3) oder zu einem Duschschauch (4) umzuleiten.
2. Thermostatarmatur nach Anspruch 1, wobei die Thermostatarmatur (1) das Mischwasser zu einer Duschsäule/einem Duschkopf (2) oder zu einem Duschschauch (4) über das Einlassmodul (5), das Mischmodul (6) und das mit zwei Auslassanschlüssen (18) ausgestaltete Verteilermodul (7) verteilt.
 3. Thermostatarmatur nach Anspruch 1, wobei die Thermostatarmatur (1.1) in einer alternativen Ausführungsform das Mischwasser zu einer Duschsäule/einem Duschkopf (2) oder zu einem an der Abdeckkappe (14.1) der Thermostatarmatur (1.1) angeordneten Duschschauch (4) über das Einlassmodul (5), das Mischmodul (6) und das mit zwei Auslassanschlüssen (18) ausgestaltete Verteilermodul (7) verteilt, wobei die Abdeckkappe (14.1) eine Befestigungshalterung (30) für einen Duschgriff und einen Einlassanschluss (31) für den Duschschauch (4) aufweist.
 4. Thermostatarmatur nach Anspruch 1, wobei die Thermostatarmatur (1.2) in einer alternativen Ausführungsform das Mischwasser zu einer Duschsäule/einem Duschkopf (2) oder zu einer Badewanne (3) oder zu einem in einem Abstand von der Thermostatarmatur (1.2) angeordneten Duschschauch (4) über das Einlassmodul (5), das Mischmodul (6) und das mit drei Auslassanschlüssen (18) ausgestaltete Verteilermodul (7) verteilt.
 5. Thermostatarmatur nach Anspruch 1, wobei die Thermostatarmatur (1.3) in einer alternativen Ausführungsform das Mischwasser zu einer Duschsäule/einem Duschkopf (2) oder zu einer Badewanne (3) oder zu einem an der Abdeckkappe (14.1) der Thermostatarmatur (1.3) angeordneten Dusch-
- schlauch (4) über das Einlassmodul (5), das Mischmodul (6) und das mit zwei Auslassanschlüssen (18) ausgestaltete Verteilermodul (7) verteilt, wobei einer der Auslassanschlüsse (18) mittels eines Verschlussstopfens (20) verschlossen ist, wobei die Abdeckkappe (14.1) eine Befestigungshalterung (30) für einen Duschgriff und einen Einlassanschluss (31) für den Duschschauch (4) aufweist.
6. Thermostatarmatur nach einem der Ansprüche 1 bis 5, wobei das Einlassmodul (5) ein Gehäuse aufweist, das an seinem oberen Teil eine Einsteckkupplung (13), einen Einlassanschluss für Kaltwasser (9) und einen weiteren Einlassanschluss für Warmwasser (10) enthält, umfassend in seinem Inneren
 - die Rückschlagventile (11) mit Filter
 - eine Auslasskammer für Kaltwasser
 - eine Auslasskammer für Heißwasser und
 - eine Einlasskammer für Mischwasser, die bei Nichtgebrauch mit einem Stopfen (20) verschlossen ist, wobei die Kammer mit einer Leitung (12) verbunden ist, die an der Vorderseite des Einlassmoduls (5) angeordnet ist.
 7. Thermostatarmatur nach den Ansprüchen 1, 3 und 5, wobei in dem Einlassmodul (5) die Mischwasser-Einlasskammer durch Entfernen des Verschlussstopfens (20) aktiviert wird, um das Mischwasser zu einem an der Abdeckkappe (14.1) der Thermostatarmatur (1.3) angeordneten Duschschauch (4) umzuleiten, wobei die an der Vorderseite des Einlassmoduls (5) angeordnete Leitung (12) durch Einsetzen eines mit dem in der Abdeckkappe (14.1) beinhaltenen Wassereinlassanschluss (31) verbundenen Verbindungsrohrs (26) aktiviert wird.
 8. Thermostatarmatur nach einem der Ansprüche 1 bis 5, wobei das Mischmodul (5) ein Gehäuse aufweist, das an seinem oberen Teil eine Einsteckkupplung (13) und an seinem unteren Teil ein Durchgangsloch (15) enthält, umfassend in seinem Inneren
 - eine Mischpatrone und andere Funktionselemente, die zur Regelung der Wassertemperatur bestimmt sind,
 - eine Kaltwasser-Einlasskammer
 - eine Heißwasser-Einlasskammer und
 - eine Mischwasser-Auslasskammer.
 9. Thermostatarmatur nach einem der Ansprüche 1 bis 5, wobei das Verteilermodul (7) ein Gehäuse mit mindestens zwei Auslassanschlüssen (18) aufweist, um das Mischwasser umzuleiten durch
 - eine Mischwasser-Einlasskammer zu der Duschsäule/dem Duschkopf (2) oder zu einer Badewanne (3) oder zu einem Duschschauch

(4) und

- eine Mischwasser-Rücklaufkammer, die bei Nichtgebrauch mittels eines Stopfens (20) verschlossen ist,

wobei es an seinem oberen Teil eine Einsteckkuppelung (13) und eine bei Nichtgebrauch mittels eines Stopfens (20) verschlossene Entleerungsleitung (19) enthält.

10. Thermostatarmatur nach den Ansprüchen 1, 3, 5 und 9, wobei in dem Verteilermodul (7) die Mischwasser-Rücklaufkammer durch Entfernen des Verschlussstopfens (20) aktiviert wird, um das Wasser zu einem an der Abdeckkappe (14.1) der Thermostatarmatur (1.1 und 1.3) angeordneten Duschschauch (4) umzuleiten.

11. Thermostatarmatur nach einem der vorhergehenden Ansprüche, wobei die wasserdichte Verbindung zwischen dem Einlassmodul (5), dem Mischmodul (6) und dem Verteilermodul (7) durch die folgenden Rohrleitungsabschnitte ausgeführt wird:

- Kaltwasser-Rohrleitungsabschnitt (22), der die Kaltwasser-Auslasskammer des Einlassmoduls (5) mit der Kaltwasser-Einlasskammer des Mischmoduls (6) verbindet,
- Heißwasser-Rohrleitungsabschnitt (23), der die Heißwasser-Auslasskammer des Einlassmoduls (5) mit der Heißwasser-Einlasskammer des Mischmoduls (6) verbindet,
- Mischwasser-Rohrleitungsabschnitt (24), der die Mischwasser-Auslasskammer des Mischmoduls (6) mit der Mischwasser-Einlasskammer des Verteilermoduls (7) verbindet,
- Mischwasserrücklauf-Rohrleitungsabschnitt (27), der die Mischwasser-Rücklaufkammer des Verteilermoduls (7) mit der Mischwasser-Einlasskammer des Einlassmoduls (5) verbindet, wobei der Mischwasserrücklauf-Rohrleitungsabschnitt (27) in der Durchgangsöffnung (15) des Mischmoduls (6) angeordnet ist.

12. Thermostatarmatur nach einem der vorhergehenden Ansprüche, wobei das Behältnis (8) aus sehr starkem, leichtem Material hergestellt ist, das Aussparungen (25), die zur Anordnung der Module der Thermostatarmatur (1, 1.1, 1.2 oder 1.3) bestimmt sind, und eine Front-Oberflächenbehandlung aufweist, die Fliesen oder eine dekorative Oberfläche darauf ermöglicht, wobei die Kappe (14 oder 14.1) und Knöpfe (16 und 21) der vorstehend genannten Thermostatarmatur auf ihre entsprechenden Module gesteckt werden und auf der Oberfläche in Position verbleiben.

13. Thermostatarmatur nach einem der vorhergehenden

den Ansprüche, wobei sie in jeder der beschriebenen Ausführungsformen zwischen dem Verteilermodul (7) und dem Betätigungsknopf (21) eine Ablassvorrichtung (28) enthält, die eine mit dem Außenbereich in Kontakt stehende Ablassleitung (29) aufweist, wobei sie auch ein Verbindungsrohr (26) enthält.

14. Thermostatarmatur nach Anspruch 13, wobei in dem Verteilermodul (7) Entleerungsleitung (19) zum Einsetzen des Verbindungsrohrs (26) aktiviert wird, das die Entleerungsleitung (19) mit der Ablassleitung (29) der Ablassvorrichtung (28) verbindet.

15. Thermostatarmatur nach einem der vorhergehenden Ansprüche, wobei sie in jeder der beschriebenen Ausführungsformen der Thermostatarmatur (1, 1.1, 1.2 oder 1.3) Längsbinder (32) zur Befestigung enthält, die, indem sie durch das Einlassmodul (5), das Mischmodul (6) und das Verteilermodul (7) verlaufen, die Struktur verstärken, wobei die Enden der Längsbinder (32) durch Verriegelungsmittel (33) befestigt sind.

Revendications

1. - Raccord thermostatique, comprenant trois modules distincts,

- module d'admission (5)
- module de mélange (6) et
- module de distribution (7) avec au moins deux liaisons de sortie (18), afin de dévier l'eau mélangée vers une colonne/pomme de douche (2), ou vers un bain (3) ou vers un flexible de douche (4), lesdits modules étant reliés les uns aux autres par le biais de secteurs de tuyauterie (22 - 23 - 24 et/ou 27),

caractérisé en ce que

- ledit raccord thermostatique (1 - 1.1 - 1.2 ou 1.3) est inséré dans un contenant (8) utilisé comme un conditionnement, envisagé pour une installation encastrée conjointe en position horizontale ou verticale,
- laissant cachés

o le module d'admission (5) par la fixation d'un capuchon de protection (14, 14.1),

o le module de mélange (6) par la fixation d'un bouton de commande (16) avec un complément d'échelle d'indication de température (17) ou un indicateur de température d'utilisation optimale,

o le module de distribution (7) par la fixation d'un bouton d'actionnement (21) afin de dévier l'eau mélangée vers une colonne/pomme de douche (2) ou vers un bain (3), ou

- vers un flexible de douche (4).
2. - Raccord thermostatique selon la revendication 1, **dans lequel** le raccord thermostatique (1) distribue l'eau mélangée vers une colonne/pomme de douche (2) ou vers un flexible de douche (4), par l'intermédiaire du module d'admission (5), du module de mélange (6) et du module de distribution (7) configuré avec deux liaisons de sortie (18).
 3. - Raccord thermostatique selon la revendication 1, **dans lequel** le raccord thermostatique (1.1), dans une variante de réalisation, distribue l'eau mélangée vers une colonne/pomme de douche (2) ou vers un flexible de douche (4) positionné sur le capuchon de protection (14.1) du raccord thermostatique (1.1), par l'intermédiaire du module d'admission (5), du module de mélange (6) et du module de distribution (7) configuré avec deux liaisons de sortie (18), ledit capuchon de protection (14.1) comprenant un support de fixation (30) pour un manche de douche et une liaison d'entrée (31) pour le flexible de douche (4).
 4. - Raccord thermostatique selon la revendication 1, **dans lequel** le raccord thermostatique (1.2), dans une variante de réalisation, distribue l'eau mélangée vers une colonne/pomme de douche (2) ou vers un bain (3) ou vers un flexible de douche (4) positionné à distance du raccord thermostatique (1.2), par l'intermédiaire du module d'admission (5), du module de mélange (6) et du module de distribution (7) configuré avec trois liaisons de sortie (18).
 5. - Raccord thermostatique selon la revendication 1, **dans lequel** le raccord thermostatique (1.3), dans une variante de réalisation, distribue l'eau mélangée vers une colonne/pomme de douche (2) ou vers un bain (3) ou vers un flexible de douche (4) positionné sur le capuchon de protection (14.1) du raccord thermostatique (1.3), par l'intermédiaire du module d'admission (5), du module de mélange (6) et du module de distribution (7) configuré avec deux liaisons de sortie (18), une des liaisons de sortie (18) étant rendue étanche à l'aide d'un bouchon d'étanchéité (20), ledit capuchon de protection (14.1) comprenant un support de fixation (30) pour un manche de douche et une liaison d'entrée (31) pour le flexible de douche (4).
 6. - Raccord thermostatique, selon une quelconque des revendications 1 à 5, **dans lequel** le module d'admission (5) comprend un boîtier qui intègre, sur sa partie supérieure, un couplage d'insertion (13), une liaison d'entrée pour l'eau froide (9) et une autre liaison d'entrée pour l'eau chaude (10), comportant à l'intérieur
 - les clapets de non-retour (11) avec filtre
 - une chambre de sortie pour l'eau froide
 - une chambre de sortie pour l'eau chaude, et
 - une chambre d'entrée pour l'eau mélangée, rendue étanche à l'aide d'un bouchon (20) lorsqu'elle n'est pas utilisée, ladite chambre étant reliée à un conduit (12) positionné devant le module d'admission (5).
 7. - Raccord thermostatique, selon les revendications 1, 3 et 5, **dans lequel** dans le module d'admission (5), la chambre d'entrée pour l'eau mélangée est activée en enlevant le bouchon d'étanchéité (20), afin de dévier l'eau mélangée vers un flexible de douche (4) positionné sur le capuchon de protection (14.1) du raccord thermostatique (1.3), le conduit (12) positionné devant ledit module d'admission (5) étant activé en insérant un tube de liaison (26) relié à la liaison d'entrée d'eau (31) comprise dans le capuchon de protection (14.1).
 8. - Raccord thermostatique, selon une quelconque des revendications 1 à 5, **dans lequel** le module de mélange (6), comprend un boîtier qui intègre, sur sa partie supérieure, un couplage d'insertion (13) et, sur sa partie inférieure, un trou traversant (15) comprenant à l'intérieur
 - une cartouche de mélange et d'autres éléments fonctionnels destinés à la régulation de température d'eau,
 - une chambre d'entrée d'eau froide,
 - une chambre d'entrée d'eau chaude, et
 - une chambre de sortie d'eau mélangée.
 9. - Raccord thermostatique, selon une quelconque des revendications 1 à 5, **dans lequel** le module de distribution (7) comprend un boîtier avec au moins deux liaisons de sortie (18) afin de dévier l'eau mélangée par le biais de
 - une chambre d'entrée d'eau mélangée, vers la colonne/pomme de douche (2) ou vers un bain (3) ou vers un flexible de douche (4), et
 - une chambre de retour d'eau mélangée, rendue étanche à l'aide d'un bouchon (20), lorsqu'elle n'est pas utilisée, intégrant sur sa partie supérieure un couplage d'insertion (13) et un conduit d'évacuation (19) rendu étanche à l'aide d'un bouchon (20), lorsqu'il n'est pas utilisé.
 10. - Raccord thermostatique, selon les revendications 1, 3, 5 et 9, **dans lequel** dans le module de distribution (7) la chambre de retour d'eau mélangée est activée en enlevant le bouchon d'étanchéité (20), afin de dévier l'eau vers un flexible de douche (4) positionné sur le capuchon de protection (14.1) du raccord thermostatique (1.1 et 1.3).

11. - Raccord thermostatique, selon une quelconque des revendications précédentes, **dans lequel** la liaison étanche entre le module d'admission (5), le module de mélange (6) et le module de distribution (7) est réalisée par le biais des secteurs de tuyauterie suivants :
- secteur de tuyauterie d'eau froide (22) qui relie la chambre de sortie d'eau froide du module d'admission (5) à la chambre d'entrée d'eau froide du module de mélange (6),
 - secteur de tuyauterie d'eau chaude (23) qui relie la chambre de sortie d'eau chaude du module d'admission (5) à la chambre d'entrée d'eau chaude du module de mélange (6),
 - secteur de tuyauterie d'eau mélangée (24) qui relie la chambre de sortie d'eau mélangée du module de mélange (6) à la chambre d'entrée d'eau mélangée du module de distribution (7),
 - secteur de tuyauterie de retour d'eau mélangée (27) qui relie la chambre de retour d'eau mélangée du module de distribution (7) à la chambre d'entrée d'eau mélangée du module d'admission (5), ledit secteur de tuyauterie de retour d'eau mélangée (27) étant positionné dans le trou traversant (15) du module de mélange (6).
12. - Raccord thermostatique, selon une quelconque des revendications précédentes, **dans lequel** le contenant (8) est composé en un matériau léger très robuste, comprenant des cavités (25) destinées au positionnement des modules du raccord thermostatique (1 - 1.1 - 1.2 ou 1.3) et une finition frontale qui permet de poser sur celle-ci un carrelage ou une surface décorative, le capuchon (14 ou 14.1) et les boutons (16 et 21) du raccord thermostatique susmentionné étant insérés sur ses modules correspondants, restant en position sur ladite surface.
13. - Raccord thermostatique, selon une quelconque des revendications précédentes, **dans lequel** il intègre, entre le module de distribution (7), dans un quelconque des modes de réalisation décrits, et le bouton d'actionnement (21), un moyen d'évacuation (28) qui comprend une ligne d'évacuation (29) en contact avec l'extérieur, intégrant également un tube de liaison (26).
14. - Raccord thermostatique selon la revendication 13, **dans lequel** dans le module de distribution (7) un conduit d'évacuation (19) est activé pour l'insertion du tube de liaison (26) qui relie ledit conduit d'évacuation (19) à la ligne d'évacuation (29) du moyen d'évacuation (28).
15. - Raccord thermostatique, selon une quelconque des revendications précédentes, **dans lequel** il intègre, dans un quelconque des modes de réalisation décrits du raccord thermostatique (1 - 1.1 - 1.2 ou 1.3), des attaches longitudinales (32) pour la fixation, qui en passant par le biais du module d'admission (5), du module de mélange (6) et du module de distribution (7), renforcent la structure, les extrémités desdites attaches longitudinales (32) étant fixées par un moyen de blocage (33).

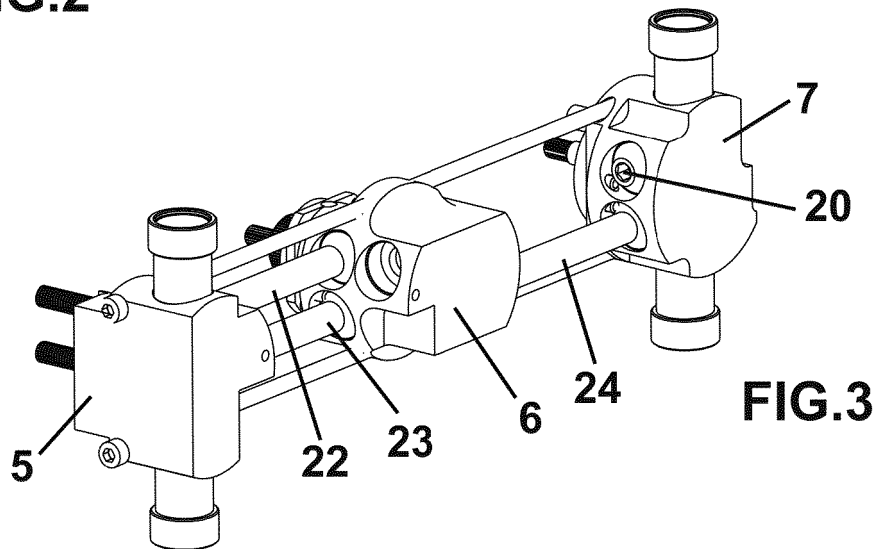
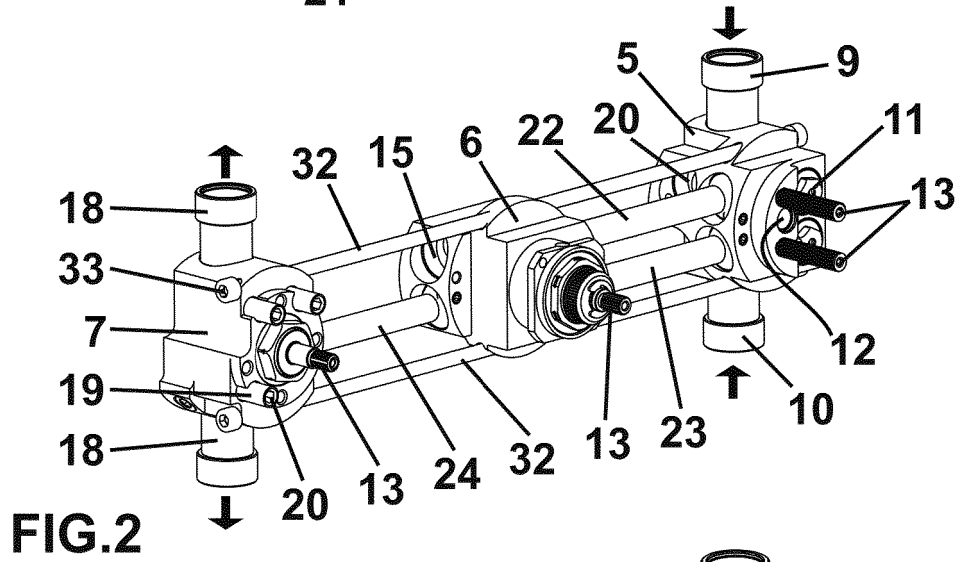
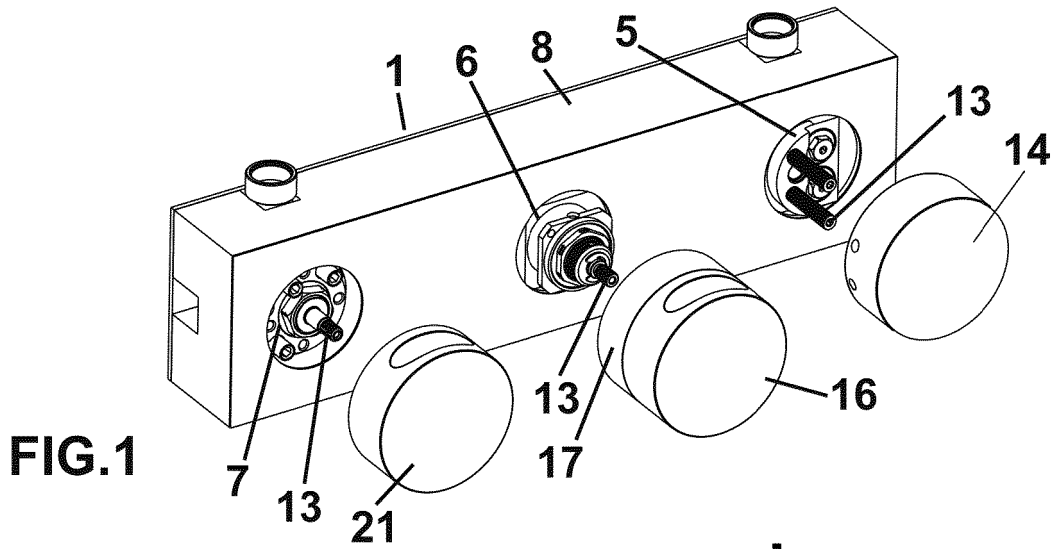

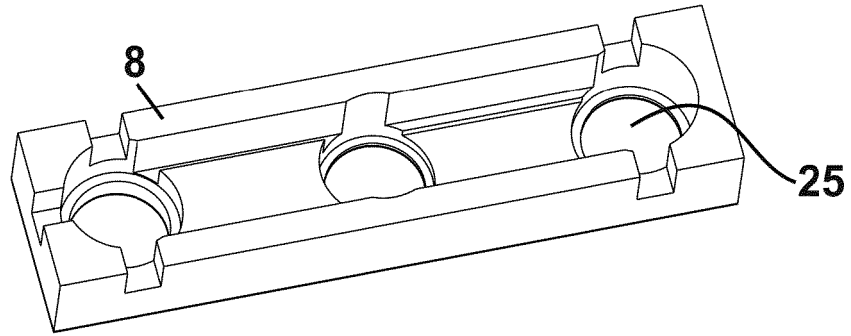

FIG. 4

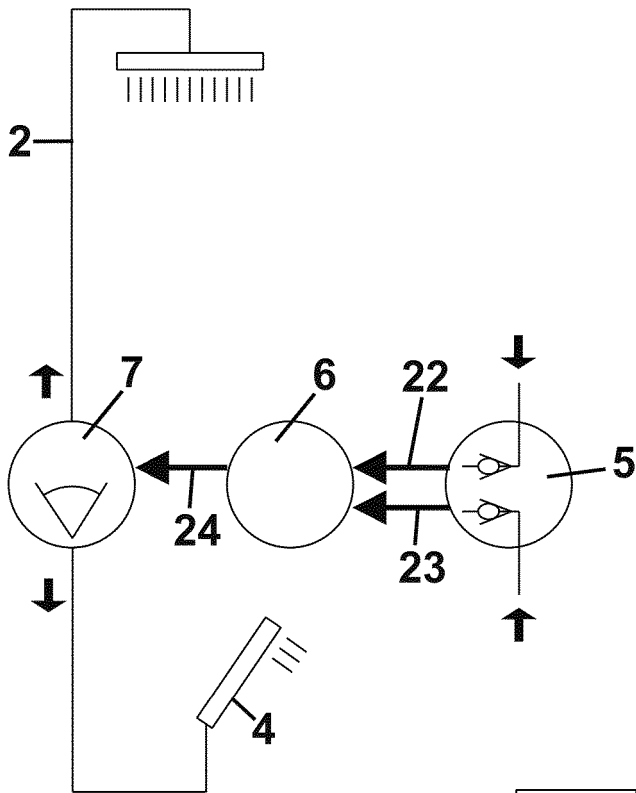

FIG. 5

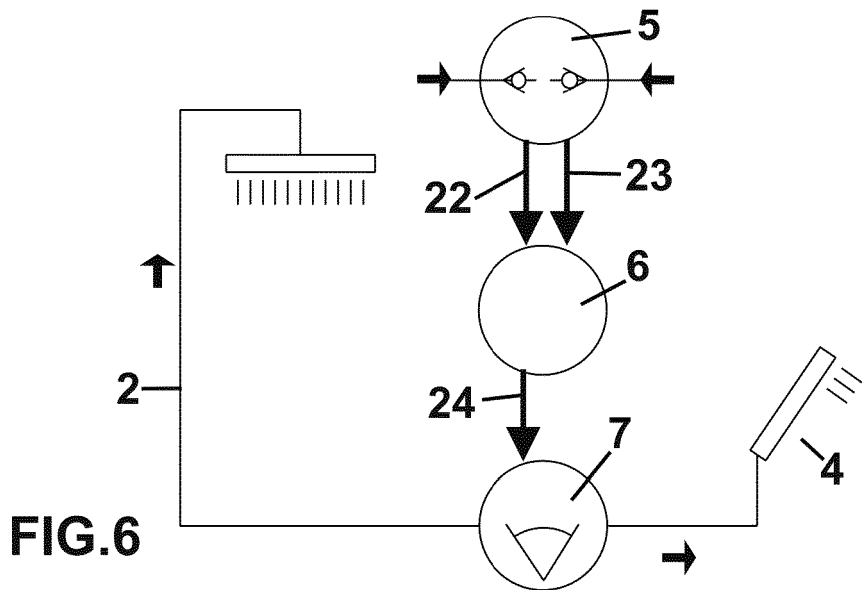
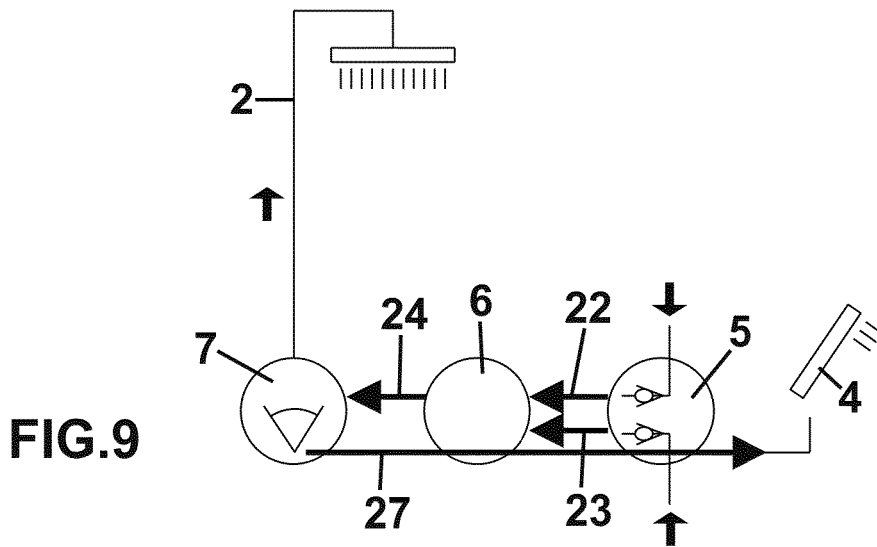
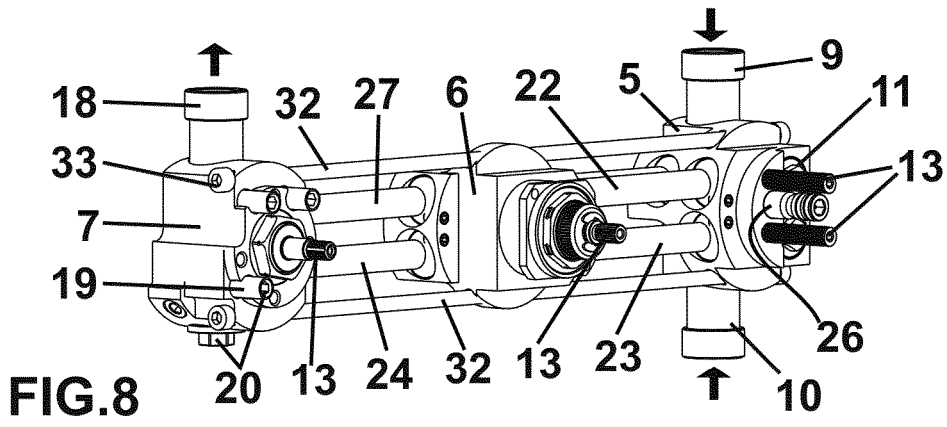
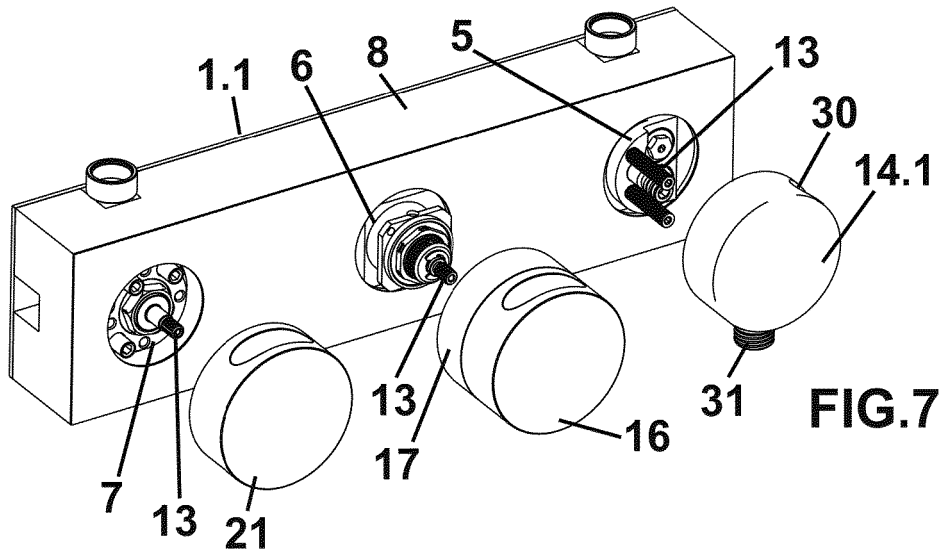
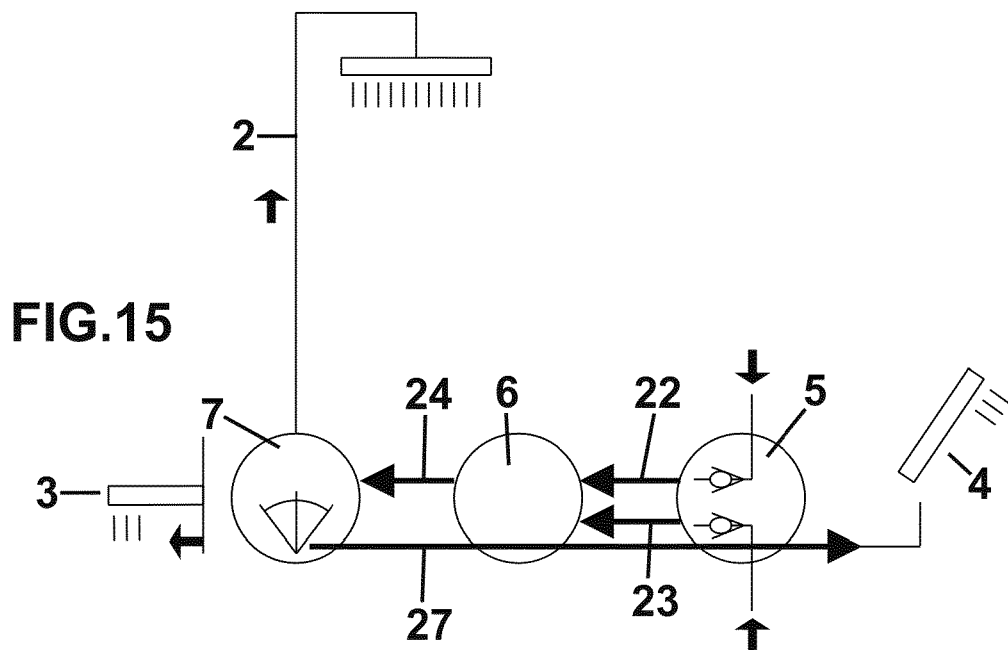
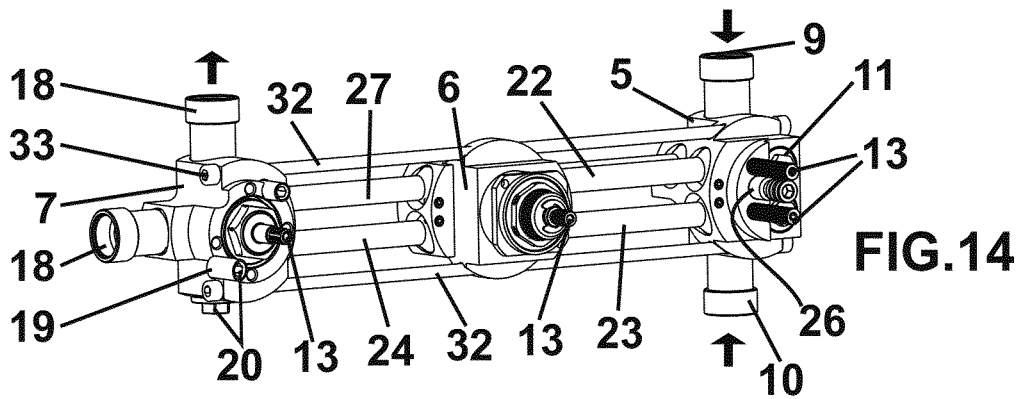
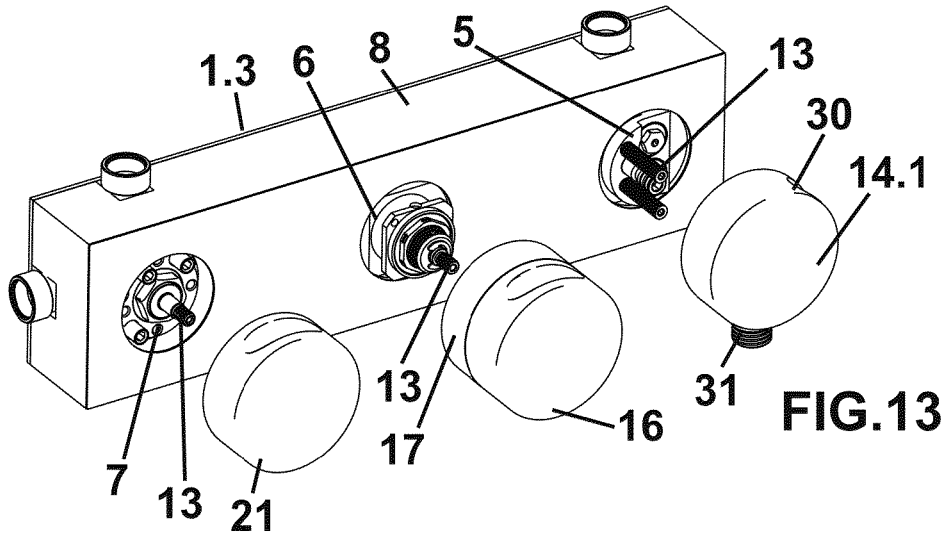
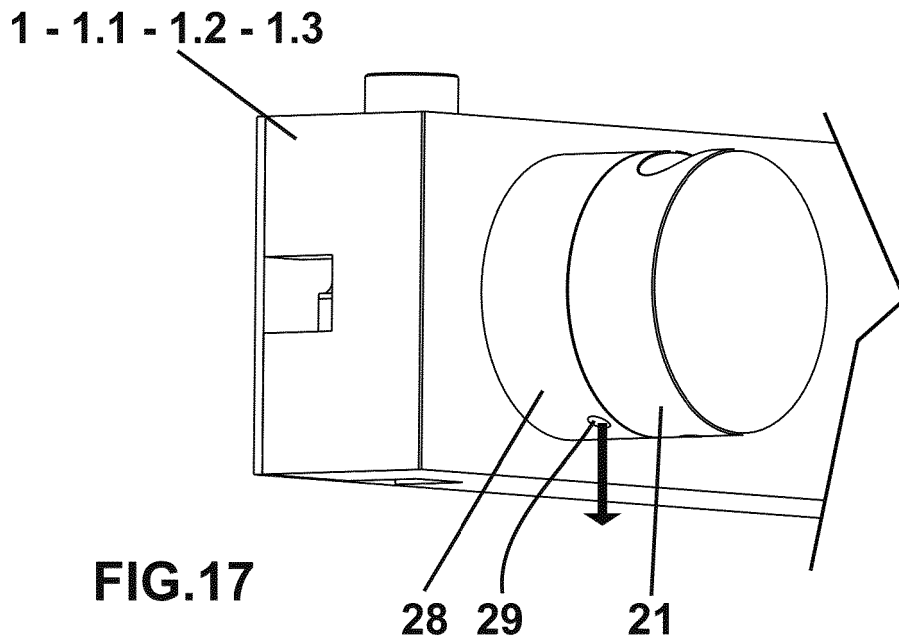
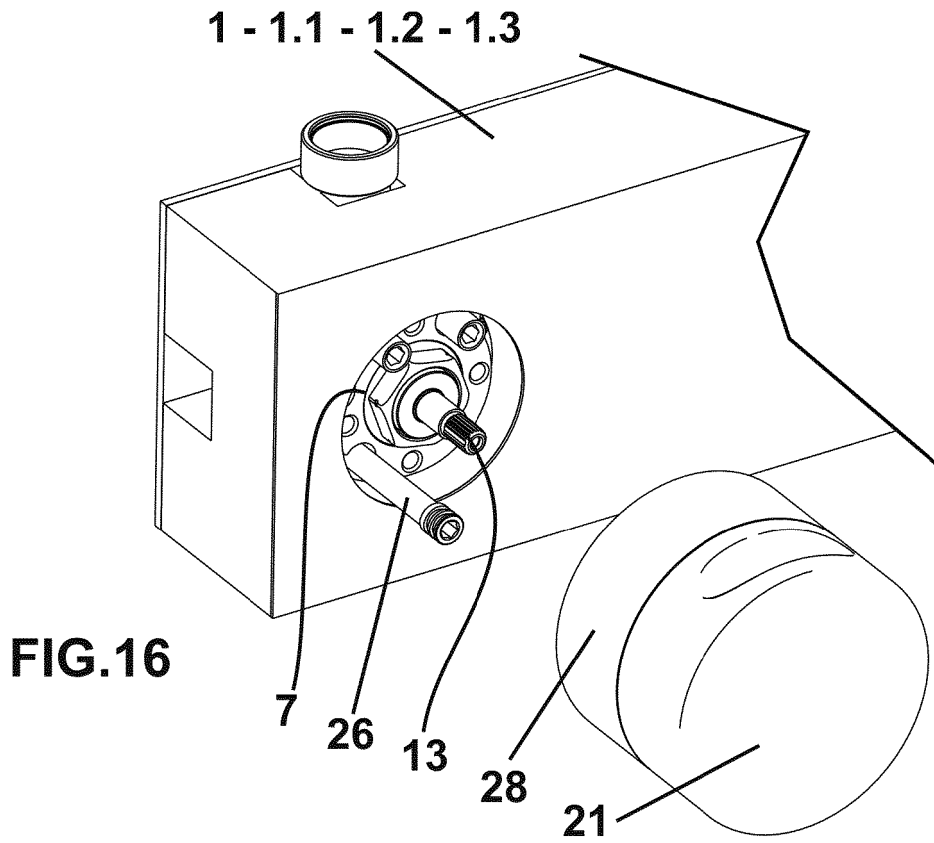

FIG. 6







REFERENCES CITED IN THE DESCRIPTION

This list of references cited by the applicant is for the reader's convenience only. It does not form part of the European patent document. Even though great care has been taken in compiling the references, errors or omissions cannot be excluded and the EPO disclaims all liability in this regard.

Patent documents cited in the description

- ES 2524022 [0006]
- EP 2508683 A1 [0007]