

(19)



(11)

EP 3 702 502 B1

(12)

EUROPEAN PATENT SPECIFICATION

(45) Date of publication and mention of the grant of the patent:
11.05.2022 Bulletin 2022/19

(51) International Patent Classification (IPC):
D04B 15/10 ^(2006.01) **D04B 15/06** ^(2006.01)
D04B 7/00 ^(2006.01) **D04B 7/04** ^(2006.01)
D04B 15/36 ^(2006.01)

(21) Application number: **19160218.4**

(52) Cooperative Patent Classification (CPC):
D04B 15/10; D04B 1/22; D04B 7/04; D04B 15/06;
D04B 15/362; D10B 2403/0221

(22) Date of filing: **01.03.2019**

(54) **FLAT KNITTING MACHINE STRUCTURE WITH ADJUSTABLE GAP BETWEEN TWO KNOCK-OVER BITS**

FLACHSTRICKMASCHINENSTRUKTUR MIT EINSTELLBAREM SPALT ZWISCHEN ZWEI ABSCHLAGPLATINEN

STRUCTURE DE TRICOTEUSE RECTILIGNE À INTERVALLE RÉGLABLE ENTRE DEUX BECS DE PLATINE D'ABATTAGE

(84) Designated Contracting States:
AL AT BE BG CH CY CZ DE DK EE ES FI FR GB GR HR HU IE IS IT LI LT LU LV MC MK MT NL NO PL PT RO RS SE SI SK SM TR

• **LEE, Chih-Chiang**
New Taipei City (TW)

(43) Date of publication of application:
02.09.2020 Bulletin 2020/36

(74) Representative: **2K Patentanwälte Blasberg Kewitz & Reichel Partnerschaft mbB Schumannstrasse 27 60325 Frankfurt am Main (DE)**

(73) Proprietor: **Pai Lung Machinery Mill Co., Ltd. New Taipei City (TW)**

(56) References cited:
EP-A1- 0 533 414 EP-A1- 1 247 887
EP-A1- 1 340 847

(72) Inventors:
• **LIN, Yu-Sheng**
New Taipei City (TW)

EP 3 702 502 B1

Note: Within nine months of the publication of the mention of the grant of the European patent in the European Patent Bulletin, any person may give notice to the European Patent Office of opposition to that patent, in accordance with the Implementing Regulations. Notice of opposition shall not be deemed to have been filed until the opposition fee has been paid. (Art. 99(1) European Patent Convention).

Description

FIELD OF THE INVENTION

[0001] The present invention relates to a flat knitting machine structure, and in particular to a flat knitting machine structure which can adjust the size of a gap through knock-over bits.

BACKGROUND OF THE INVENTION

[0002] The existing knitting of three-dimensional fabric with adjustable thickness is generally realized by a warp knitting machine, as disclosed in patents of CN 102704180A, CN 102978823A and CN 105220347A. Further prior art documents to be mentioned are: EP 1 340 847 A1; EP 0 533 414 A1 and EP 1 247 887 A1.

[0003] Thus, a flat knitting machine structure with an adjustable gap between two knock-over bits is known, the structure comprising: two needle beds comprising a plurality of needles, wherein each of the plurality of needles defines a needle extending line and comprises a butt which is positioned on the needle extending line; and two cam systems, respectively disposed to face one of the needle beds, wherein each of the cam systems comprises a needle cam to provide the butts being placed and guide each of the plurality of needles to make a knitting stroke towards the gap.

[0004] However, the problem that the existing flat knitting machine cannot knit the foregoing mentioned fabric results from the flat knitting machine comprising fixed knock-over bits to define a gap therebetween, which is causing that the flat knitting machine can only knit the fabric with a single thickness.

SUMMARY OF THE INVENTION

[0005] The main purpose of the present invention is to solve an applied problem derived from a constant gap of the flat knitting machine.

[0006] To achieve the above purpose, the present invention resides in that the two needle beds respectively comprise a plurality of knock-over bits disposed to correspond to each of the plurality of needles, the plurality of knock-over bits facing each other to define the gap, wherein a distance of the gap is equal to a space between two knock-over bits facing each other, each of the plurality of knock-over bits comprises a control butt disposed at a same side as each of the butts, an extending section provided with the control butt, a bending section connected with the extending section and a loop hanging section connected with the bending section as well as paralleled to a front edge of one of the needles, and wherein each of the control butts is respectively positioned on one of the needle extending lines in which one of the plurality of needles is correspondingly disposed; and the two cam systems respectively comprise a knock-over bit cam providing the control butts being placed, wherein the knock-

over bit cam is controlled to define a displacement stroke for driving the plurality of knock-over bits to change the size of the gap.

[0007] Accordingly, the invention provides a flat knitting machine structure with a gap to be adjustable, including two needle beds and two cam systems which are respectively disposed to face one of the needle beds. Each of the needle beds comprises a plurality of needles and a plurality of knock-over bits which are respectively disposed to correspond to each of the plurality of needles. Each of the plurality of needles comprises a butt. Each of the plurality of knock-over bits comprises a control butt disposed at a same side as each of the butts. The two needle beds are disposed at interval so that the plurality of knock-over bits face each other to define a gap, wherein the distance of the gap is equal to a space between two knock-over bits facing each other. Each of the plurality of needles defines a needle extending line. Each of the butts is respectively positioned on one of the needle extending lines. Each of the control butts is respectively positioned on one of needle extending lines in which one of the plurality of needles is correspondingly disposed. Each of the plurality of knock-over bits comprises an extending section provided with the control butt, a bending section connected with the extending section, and a loop hanging section connected with the bending section as well as paralleled to a front edge of one of the needles. Each of the cam systems comprises a needle cam to provide the butts being placed and guide each of the plurality of needles to make a knitting stroke towards the gap, and a knock-over bit cam provides the control butts being placed. The knock-over bit cam is controlled to define a displacement stroke for driving the plurality of knock-over bits to change the size of the gap.

[0008] In an embodiment, each of the plurality of knock-over bits comprises a wire mounting hole for loosening loop located on the loop hanging section, and at least one wire mounting hole for limiting position located on the extending section.

[0009] In an embodiment, each of the needle beds comprises a plurality of chutes respectively disposed on a needle bed base; and each of the plurality of knock-over bits comprises a bottom positioned at the loop hanging section for the knock-over bit cam sliding in the chute under the displacement stroke.

[0010] In an embodiment, each of the knock-over bit cams comprises a first guide section, a straight section connected with the first guide section, and a second guide section connected with the straight section, the first guide section and the second guide section are respectively tapered towards the straight section; and the size of the straight section is constant.

[0011] In an embodiment, each of the knock-over bit cams is respectively disposed at one side of one of the cam systems where faces the gap.

[0012] As previously disclosed in the present invention, compared with the prior art, the present invention has the following characteristics: the cam systems in the

flat knitting machine structure of the present invention include the knock-over bit cams to move the knock-over bit according to knitting needs so that the gap of the flat knitting machine structure is adjustable to knit a three-dimensional fabric with different thicknesses.

BRIEF DESCRIPTION OF THE DRAWINGS

[0013]

Fig. 1 is a structural schematic diagram of a flat knitting machine in an embodiment of the present invention;

Fig. 2 is a structural schematic diagram of a needle bed part with a small gap in an embodiment of the present invention;

Fig. 3 is a structural schematic diagram of a needle bed part with a large gap in an embodiment of the present invention;

Fig. 4 is a structural schematic diagram of a knock-over bit in an embodiment of the present invention;

Fig. 5 is a schematic diagram of a structural relationship between a knock-over bit and a needle in an embodiment of the present invention;

Fig. 6 is a partial enlarged diagram of a structural relationship between a knock-over bit and a needle in an embodiment of the present invention;

Fig. 7 is a structural schematic diagram of a cam system in an embodiment of the present invention;

Fig. 8 is an implementation diagram of a cam system in an embodiment of the present invention; and

Fig. 9 is a structural schematic diagram of a three-dimensional fabric with adjustable thickness.

DETAILED DESCRIPTION OF THE PREFERRED EMBODIMENTS

[0014] The details and technical contents of the present invention will be described below with reference to drawings.

[0015] Referring to Figs. 1, 2, 3, 4, 5, 6, 7, 8 and 9, the present invention provides a flat knitting machine structure 100 which is able to change the size of a gap 10 in accordance with knitting requirements during knitting process, so as to change the thickness of a three-dimensional fabric 90 (also called spacer fabric) in the knitting process. The flat knitting machine structure 100 includes two needle beds 11 and 12 and two cam systems 13(14) which are respectively disposed to face one of the needle beds 11(12). The two needle beds 11 and 12 mean a front needle bed and a rear needle bed in the current industry, wherein the two needle beds 11 and 12 are disposed in an inclined angle to correspond to each other. The two needle beds 11 and 12 are disposed at interval to form a space therebetween. Each of the needle beds 11(12) comprises a plurality of needles 15 and a plurality of knock-over bits 16 which are respectively disposed to correspond to each of the plurality of needles 15. The

plurality of knock-over bits 16 of the present invention are not sinkers. Although the plurality of knock-over bits 16 are designed to be adjustable, however the plurality of knock-over bits 16 do not move when one of the plurality of corresponding needles 15 moves. Moreover, the gap 10 of the present invention is defined by the plurality of knock-over bits 16 of the two needle beds 11 and 12 that face each other. The distance of the gap 10 is equal to the space 101 (as shown in the figure) between two knock-over bits 16 which are facing each other. Referring to Figs. 3, 4, 5 and 6, each of the plurality of needles 15 comprises a butt 151. Each of the plurality of knock-over bits 16 comprises a control butt 161 disposed at a same side as each of the butts 151. Further, each of the plurality of knock-over bits 16 is respectively overlapped on one of the plurality of corresponding needles 15, and the butt 151 is disposed at one side of the needle 15 opposing to a needle bed base 17. The control butt 161 is disposed at one side of the plurality of knock-over bits 16 opposing to the needle bed base 17. Referring to Fig. 6, each of the plurality of needles 15 may define a needle extending line 152. The butt 151 on the needle 15 is positioned on the needle extending line 152. The control butts 161 corresponding to the needle 15 on one of the plurality of knock-over bits 16 is also positioned on the needle extending line 152. Furthermore, in order to ensure that the control butt 161 and the butt 151 are positioned on the same needle extending line 152, the length of each of the plurality of knock-over bits 16 is shorter than the total length of the plurality of needles 15.

[0016] Referring to Fig. 4 and Fig. 6, in an embodiment, each of the plurality of knock-over bits 16 comprises an extending section 162 provided with the control butt 161, a bending section 163 connected with the extending section 162, and a loop hanging section 164 connected with the bending section 163 as well as paralleled to a front edge of one needle 15. Further, the extending section 162 is overlapped above the needle 15. The bending section 163 allows the loop hanging section 164 and the extending section 162 are positioned on different extending lines, and allows the loop hanging section 164 to parallel with the needle 15 and hang a loop when the needle 15 moves. Moreover, each of the plurality of knock-over bits 16 also comprises a wire mounting hole for loosening loop 165 located on the loop hanging section 164, and at least one wire mounting hole for limiting position 166 located on the extending section 162. Referring to Figs. 5 and 6, in an embodiment, the plurality of knock-over bits 16 are implemented with two different thicknesses on the loop hanging section 164. Further, the thickness of the loop hanging section 164 of the knock-over bits 16 is able to be implemented with thicknesses smaller than the thickness of other parts of the knock-over bits 16, as shown in Fig. 6. Referring to Fig. 2 and Fig. 4, each of the needle beds 11 comprises a plurality of chutes 171 respectively formed on the needle bed base 17. Each of the plurality of knock-over bits 16 comprises a bottom 167 positioned at the loop hanging section 164 and dis-

posed into the chute 171.

[0017] Referring to Figs. 2, 7 and 8, in another aspect, each of the cam systems 13(14) is respectively disposed to face one of needle beds 11(12). Each of the cam systems 13(14) comprises a needle cam 131 to provide the butts 151 being placed, and a knock-over bit cam 132 provides the control butts 161 being placed. The needle cam 131 and the knock-over bit cam 132 may be formed by at least one cam unit. The needle cam 131 comprises a convex and a valley which are continuous so that the butts 151 disposed therein make a knitting stroke towards the gap 10 when each of the cam systems 13(14) is operated. Moreover, in an embodiment, the knock-over bit cam 132 comprises a first guide section 134, a straight section 135 connected with the first guide section 134, and a second guide section 136 connected with the straight section 135. The first guide section 134 and the second guide section 136 are respectively tapered towards the straight section 135, and the size of the straight section 135 is constant. Further, the first guide section 134 and the second guide section 136 are designed to be tapered in order to actually guide the control butts 161 after the knock-over bit cam 132 moves. Furthermore, each of the knock-over bit cams 132 is respectively disposed at one side of each of the cam system 13(14) where faces the gap 10.

[0018] Based on the foregoing mentioned, the knock-over bit cam 132 of the present invention determines the position of each of the plurality of knock-over bits 16, so as to change the size of the gap 10. Unlike the needle cam 131, the knock-over bit cam 132 does not have the convex and the valley obviously. Most of guiding portions in the knock-over bit cam 132, which guides each of the plurality of knock-over bits 16, are straight. However, in the present invention, the knock-over bit cam 132 is controlled to define a displacement stroke 133. In the displacement stroke 133, the knock-over bit cam 132 makes one-dimensional motion relative to a cam base 137 and simultaneously drives each of the plurality of knock-over bits 16 to displace, so as to change the position of each of the plurality of knock-over bits 16. Thus, the size of the gap 10 is changed, and the foregoing-mentioned displacement of the knock-over bit cam 132 is shown in Fig. 2 and Fig. 3.

[0019] Based on this, each of the knock-over bit cams 132 of the present invention is also connected with a motion mechanism. The motion mechanism drives each of the knock-over bit cams 132 to make the displacement stroke 133 according to an accepted control signal. The generation of the control signal is set based on a programming. Thus, in the knitting process of the three-dimensional fabric 90, the thickness of the three-dimensional fabric 90 is changed, and the three-dimensional fabric 90 is even allowed to generate a structure with concave and convex outside the plane.

Claims

1. A flat knitting machine structure (100) with an adjustable gap between two knock-over bits (16), comprising:

two needle beds (11, 12), disposed at interval respectively comprising a plurality of needles (15), wherein each of the plurality of needles (15) defines a needle extending line (152) and comprises a butt (151) which is positioned on the needle extending line (152); and

two cam systems (13), respectively disposed to face one of the needle beds (11 or 12), wherein each of the cam systems (13) comprises a needle cam (131) to provide the butts (151) being placed and guide each of the plurality of needles (15) to make a knitting stroke (153) towards the gap (10),

the two needle beds (11, 12) respectively comprise a plurality of knock-over bits (16) disposed to correspond to each of the plurality of needles (15), the plurality of knock-over bits (16) facing each other to define a gap (10),

wherein a distance of the gap (10) is equal to a space (101) between two knock-over bits (16) facing each other,

wherein the flat knitting machine structure (100) is **characterized in that** each of the plurality of knock-over bits (16) comprises a control butt (161) disposed at a same side as each of the butts (151), an extending section (162) provided with the control butt (161), a bending section (163) connected with the extending section (162) and a loop hanging section (164) connected with the bending section (163) as well as paralleled to a front edge of one of the needles (15), and wherein each of the control butts (161) is respectively positioned on one of the needle extending lines (152) in which one of the plurality of needles (15) is correspondingly disposed; and

the two cam systems (13) respectively comprise a knock-over bit cam (132) providing the control butts (161) being placed, wherein the knock-over bit cam (132) is controlled to define a displacement stroke (133) for driving the plurality of knock-over bits (16) to change the size of the gap (10).

2. The flat knitting machine structure (100) with an adjustable gap between two knock-over bits of claim 1, wherein each of the plurality of knock-over bits (16) comprises a wire mounting hole for loosening loop (165) located on the loop hanging section (164), and at least one wire mounting hole for limiting position (166) located on the extending section (162).

3. The flat knitting machine structure (100) with an adjustable gap between two knock-over bits of claim 2, wherein each of the needle beds (11 or 12) comprises a plurality of chutes (171) respectively disposed on a needle bed base (17); and each of the plurality of knock-over bits (16) comprises a bottom (167) positioned at the loop hanging section (164) sliding in the chute (171) under the displacement stroke (133) of the knock-over bit cam (132).
4. The flat knitting machine structure (100) with an adjustable gap between two knock-over bits of one of the preceding claims, wherein each of the knock-over bit cams (132) comprises a first guide section (134), a straight section (135) connected with the first guide section (134), and a second guide section (136) connected with the straight section (135), the first guide section (134) and the second guide section (136) are respectively tapered towards the straight section (135); and the size of the straight section (135) is constant.
5. The flat knitting machine structure (100) with an adjustable gap between two knock-over bits of claim 1 or 4, wherein each of the knock-over bit cams (132) is respectively disposed at one side of one of the cam systems (13) which faces the gap (10).

Patentansprüche

1. Flachstrickmaschinenstruktur (100) mit einem einstellbaren Spalt zwischen zwei Abschlagplatinen (16), umfassend:
- zwei Nadelbetten (11, 12), die im Abstand angeordnet sind und jeweils eine Vielzahl von Nadeln (15) umfassen, wobei jede der Vielzahl von Nadeln (15) eine Nadelverlängerungslinie (152) definiert und einen Stumpf (151) umfasst, der auf der Nadelverlängerungslinie (152) positioniert ist; und
- zwei Mitnehmersysteme (13), die jeweils so angeordnet sind, dass sie einem der Nadelbetten (11 oder 12) zugewandt sind, wobei jedes der Mitnehmersysteme (13) ein Nadelmitnehmer (131) umfasst, um dafür zu sorgen, dass die Stümpfe (151) platziert werden, und um jede der Vielzahl von Nadeln (15) so zu führen, dass sie einen Strickhub (153) in Richtung des Spalts (10) ausführen,
- wobei die beiden Nadelbetten (11, 12) jeweils eine Vielzahl von Abschlagplatinen (16) umfassen, die so angeordnet sind, dass sie jeder der Vielzahl von Nadeln (15) entsprechen, wobei die Vielzahl von Abschlagplatinen (16) einander zugewandt sind, um einen Spalt (10) zu definieren, wobei ein Abstand des Spalts (10) gleich einem

Raum (101) zwischen zwei einander zugewandten Abschlagplatinen (16) ist,

wobei die Flachstrickmaschinenstruktur (100) **dadurch gekennzeichnet ist, dass** jede der Vielzahl von Abschlagplatinen (16) einen Steuerstumpf (161) aufweist, der auf derselben Seite wie jeder der Stümpfe (151) angeordnet ist, einen Verlängerungsabschnitt (162), der mit dem Steuerstumpf (161) versehen ist, einen Biegeabschnitt (163), der mit dem Verlängerungsabschnitt (162) verbunden ist, und einen Schlaufenaufhängeabschnitt (164), der mit dem Biegeabschnitt (163) verbunden ist sowie parallel zu einer Vorderkante einer der Nadeln (15) verläuft, und wobei jeder der Steuerstümpfe (161) jeweils auf einer der Nadelverlängerungslinien (152) positioniert ist, in der eine der Vielzahl von Nadeln (15) entsprechend angeordnet ist; und

wobei die beiden Nockensysteme (13) jeweils einen Abschlagplatinen-Mitnehmer (132) umfassen, der die Steuerstümpfe (161) bereitstellt, die platziert werden, wobei der Abschlagplatinen-Mitnehmer (132) gesteuert wird, um einen Verschiebungshub (133) zum Antreiben der Vielzahl von Abschlagplatinen (16) zu definieren, um die Größe des Spalts (10) zu ändern.

2. Flachstrickmaschinenkonstruktion (100) mit einem einstellbaren Spalt zwischen zwei Abschlagplatinen nach Anspruch 1, wobei jedes der mehreren Abschlagplatinen (16) ein Drahtbefestigungsloch zum Lösen der Masche (165), die sich am Maschenaufhängeabschnitt (164) befindet, und mindestens ein Drahtbefestigungsloch zur Begrenzung der Position (166), die sich am Ausziehabschnitt (162) befindet, aufweist.
3. Flachstrickmaschinenkonstruktion (100) mit einem einstellbaren Spalt zwischen zwei Abschlagplatinen nach Anspruch 2, wobei jedes der Nadelbetten (11 oder 12) eine Vielzahl von Rutschen (171) aufweist, die jeweils auf einer Nadelbettbasis (17) angeordnet sind; und wobei jedes der Vielzahl von Abschlagplatinen (16) einen Boden (167) aufweist, der an dem Maschenaufhängeabschnitt (164) positioniert ist und in der Rutsche (171) unter dem Verschiebungshub (133) des Abschlagplatinen-Mitnehmers (132) gleitet.
4. Flachstrickmaschinenkonstruktion (100) mit einem einstellbaren Spalt zwischen zwei Abschlagplatinen nach einem der vorhergehenden Ansprüche, wobei jeder der Abschlagplatinen-Mitnehmer (132) einen ersten Führungsabschnitt (134), einen mit dem ersten Führungsabschnitt (134) verbundenen geraden Abschnitt (135) und einen mit dem geraden Abschnitt (135) verbundenen zweiten Führungsab-

schnitt (136) aufweist, wobei der erste Führungsabschnitt (134) und der zweite Führungsabschnitt (136) jeweils zum geraden Abschnitt (135) hin verjüngt sind; und wobei die Größe des geraden Abschnitts (135) konstant ist.

5. Flachstrickmaschinenstruktur (100) mit einem einstellbaren Spalt zwischen zwei Abschlagplatinen nach Anspruch 1 oder 4, wobei jeder der Abschlagplatinen-Mitnehmer (132) jeweils an einer Seite eines der Mitnehmersysteme (13) angeordnet ist, die dem Spalt (10) zugewandt ist.

Revendications

1. Une structure de tricoteuse rectiligne (100) à intervalle réglable entre deux platines d'abattage (16), comprenant :

deux lits d'aiguilles (11, 12) espacés et comprenant chacun une pluralité d'aiguilles (15), chacune de la pluralité d'aiguilles (15) définissant une ligne d'extension d'aiguille (152) et comprenant un moignon (151) positionné sur la ligne d'extension d'aiguille (152) ; et

deux systèmes d'entraînement (13), chacun étant disposé de manière à faire face à l'une des fontures (11 ou 12), chacun des systèmes d'entraînement (13) comprenant un entraîneur d'aiguille (131) pour faire en sorte que les moignons (151) soient placés et pour guider chacune de la pluralité d'aiguilles (15) de manière à ce qu'elles effectuent une course de tricotage (153) en direction de la fente (10),

dans lequel les deux lits d'aiguilles (11, 12) comprennent chacun une pluralité de platines d'abattage (16) disposées de manière à correspondre à chacune de la pluralité d'aiguilles (15), la pluralité de platines d'abattage (16) se faisant face pour définir une fente (10), une distance de la fente (10) étant égale à un espace (101) entre deux platines d'abattage (16) se faisant face,

la structure de tricoteuse rectiligne (100) étant **caractérisée en ce que**

chacune de la pluralité de platines d'abattage (16) comprend un moignon de commande (161) disposé du même côté que chacun des moignons (151), une partie d'extension (162) munie du moignon de commande (161), une partie de pliage (163) reliée à la partie d'extension (162), et une partie de suspension de boucle (164) reliée à la partie de flexion (163) et s'étendant parallèlement à un bord avant de l'une des aiguilles (15), et dans lequel chacun des moignons de commande (161) est positionné respectivement sur l'une des lignes d'extension d'aiguille (152) dans laquelle l'une de la pluralité d'aiguilles (15)

est respectivement disposée; et

dans lequel les deux systèmes de came (13) comprennent chacun un entraîneur de plaque d'abattage (132) fournissant les moignons de commande (161) qui sont placés, l'entraîneur de plaque d'abattage (132) étant commandé pour définir une course de déplacement (133) pour entraîner la pluralité de plaques d'abattage (16) afin de modifier la taille de l'espace (10).

2. Le structure structure de tricoteuse rectiligne (100) à intervalle réglable entre deux platines d'abattage selon la revendication 1, dans laquelle chacune de la pluralité de platines d'abattage (16) comprend un trou de fixation de fil pour libérer la maille (165) située au niveau de la partie de suspension de maille (164) et au moins un trou de fixation de fil pour limiter la position (166) située au niveau de la partie d'extraction (162).

3. Le structure structure de tricoteuse rectiligne (100) à intervalle réglable entre deux platines d'abattage selon la revendication 2, dans laquelle chacune des fontures d'aiguilles (11 ou 12) comprend une pluralité de goulottes (171), chacune étant disposée sur une base de fonture d'aiguilles (17) ; et dans laquelle chacune de la pluralité de platines d'abattage (16) comprend un fond (167) positionné sur la partie de suspension de maille (164) et coulissant dans la goulotte (171) sous la course de déplacement (133) de l'entraîneur de platine d'abattage (132).

4. Le structure structure de tricoteuse rectiligne (100) à intervalle réglable entre deux platines d'abattage selon selon l'une quelconque des revendications précédentes, dans laquelle chacun des entraîneurs de platine d'abattage (132) comprend une première partie de guidage (134), une partie rectiligne (135) reliée à la première partie de guidage (134) et une deuxième partie de guidage (136) reliée à la partie rectiligne (135), la première partie de guidage (134) et la deuxième partie de guidage (136) étant chacune effilée vers la partie rectiligne (135) ; et dans lequel la taille de la section droite (135) est constante.

5. Le structure structure de tricoteuse rectiligne (100) à intervalle réglable entre deux platines d'abattage selon selon la revendication 1 ou 4, dans laquelle chacun des entraîneurs de platine d'abattage (132) est disposé respectivement sur un côté de l'un des systèmes d'entraîneurs (13) qui est orienté vers la fente (10).

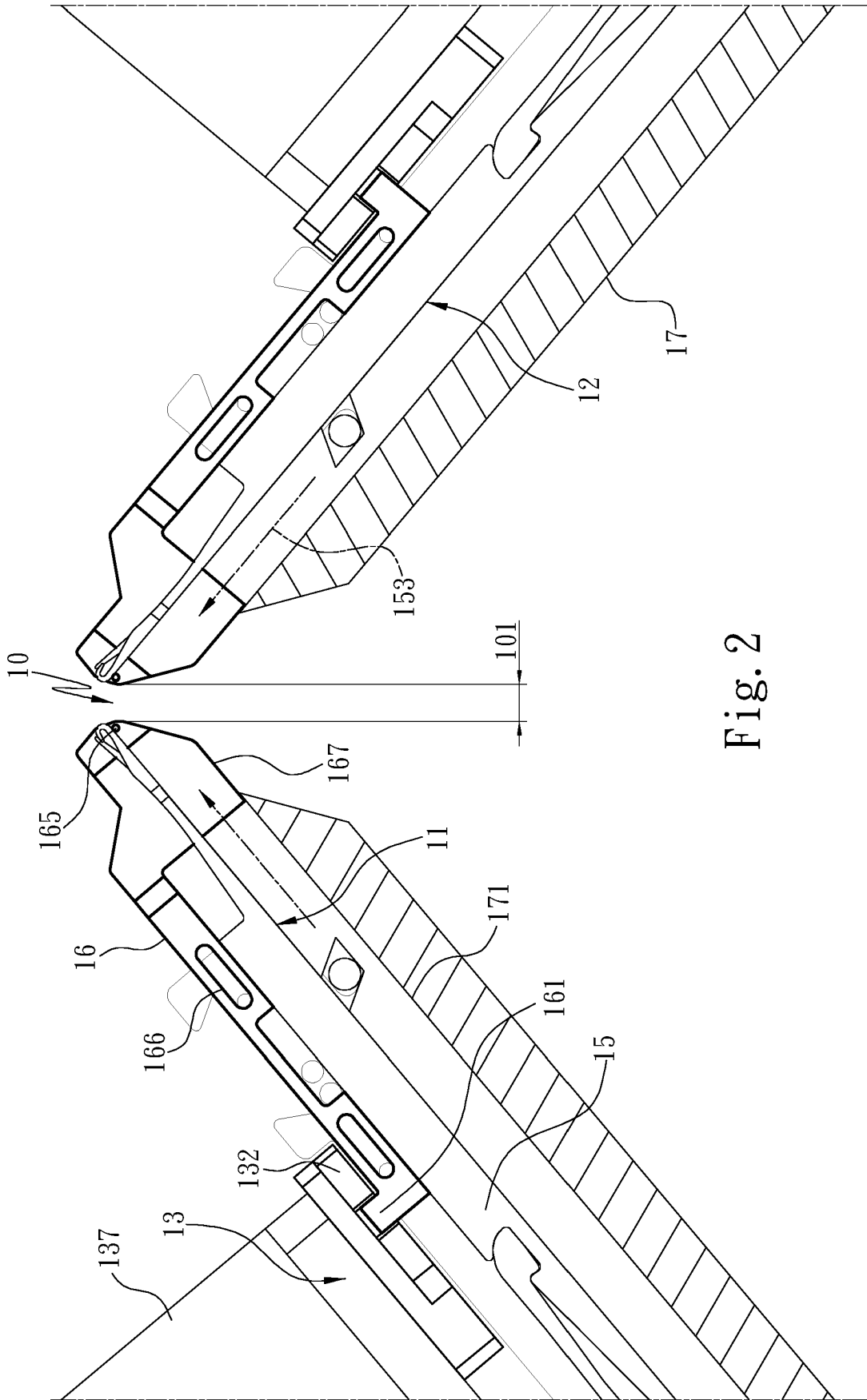

Fig. 2

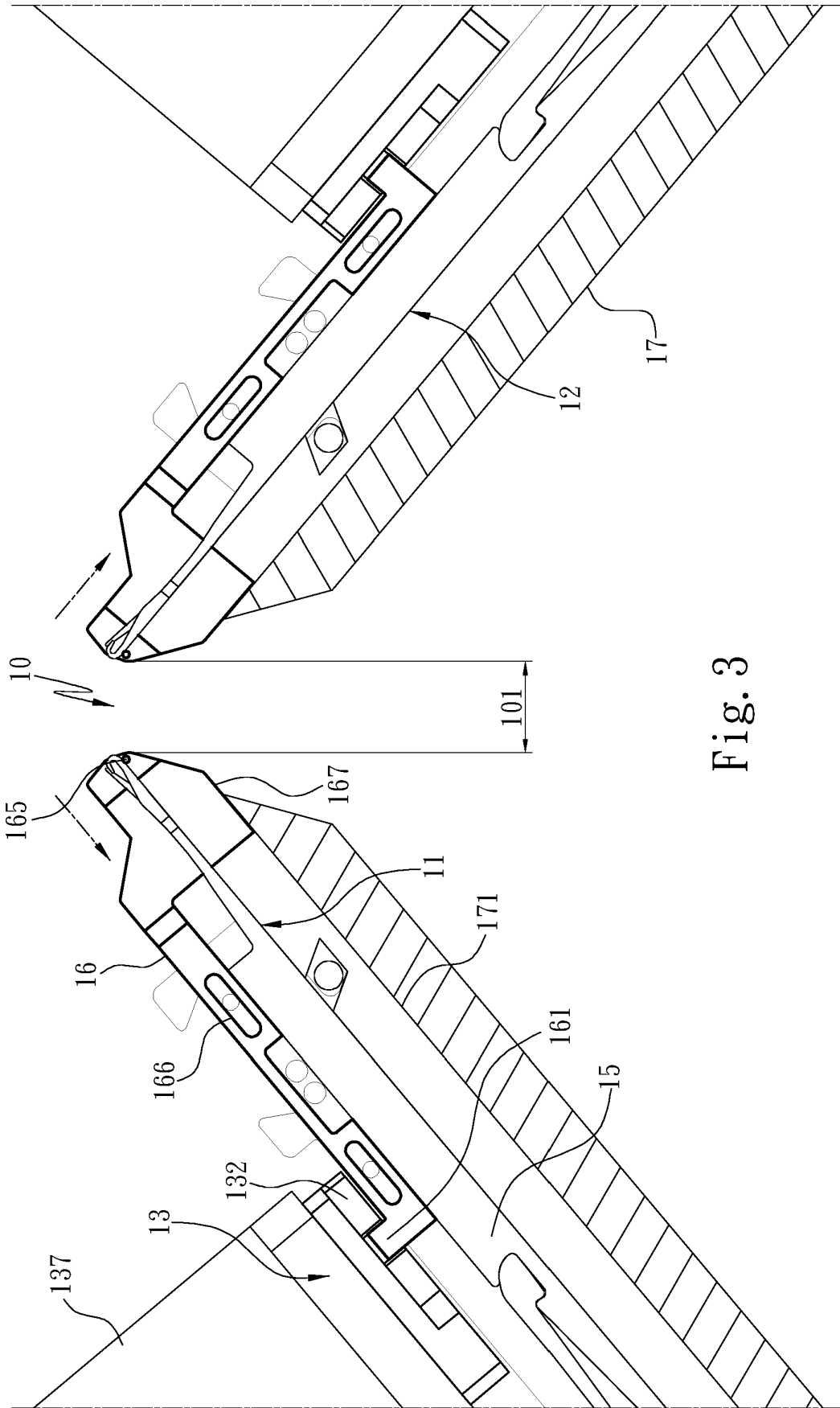
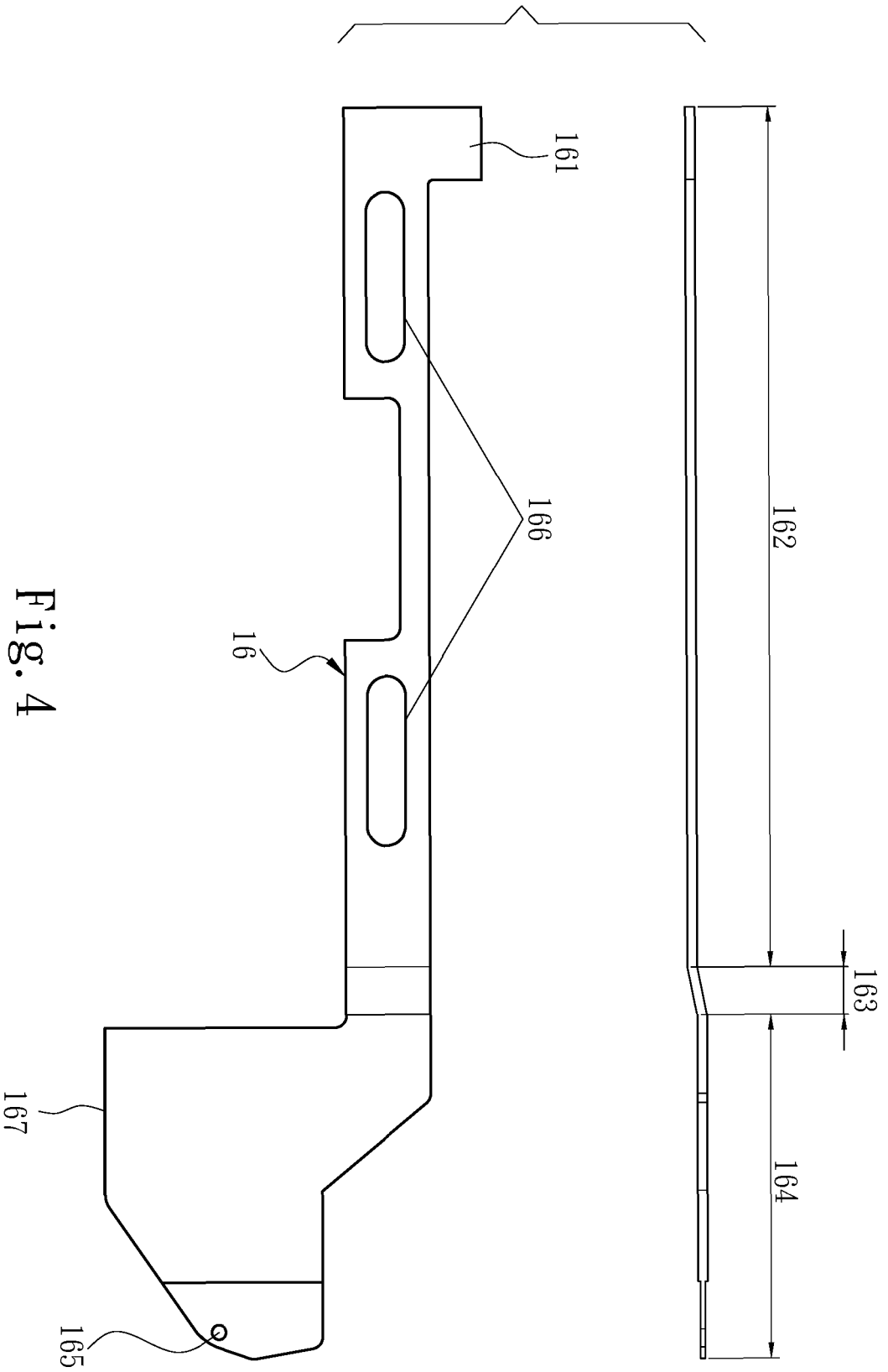

Fig. 3



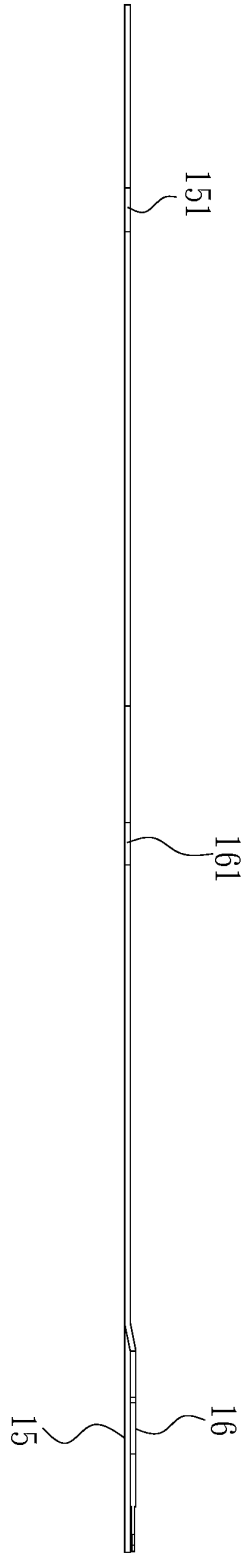

Fig. 5

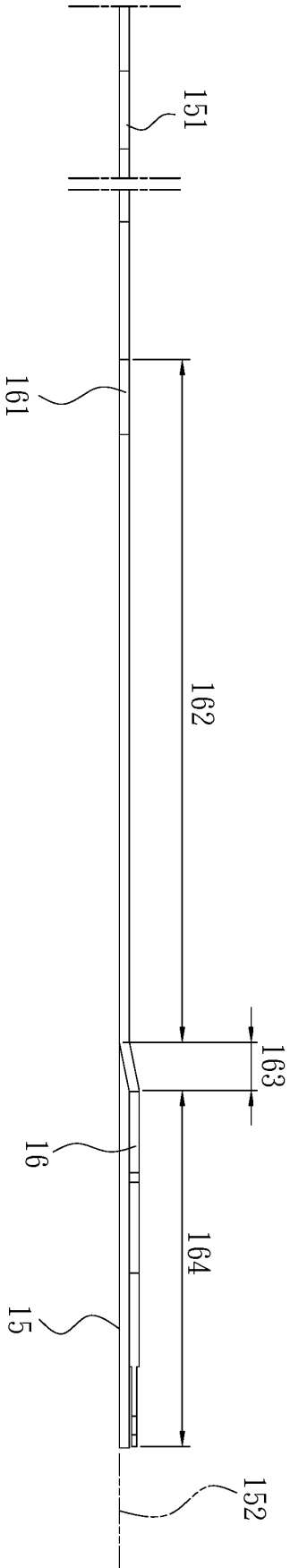

Fig. 6

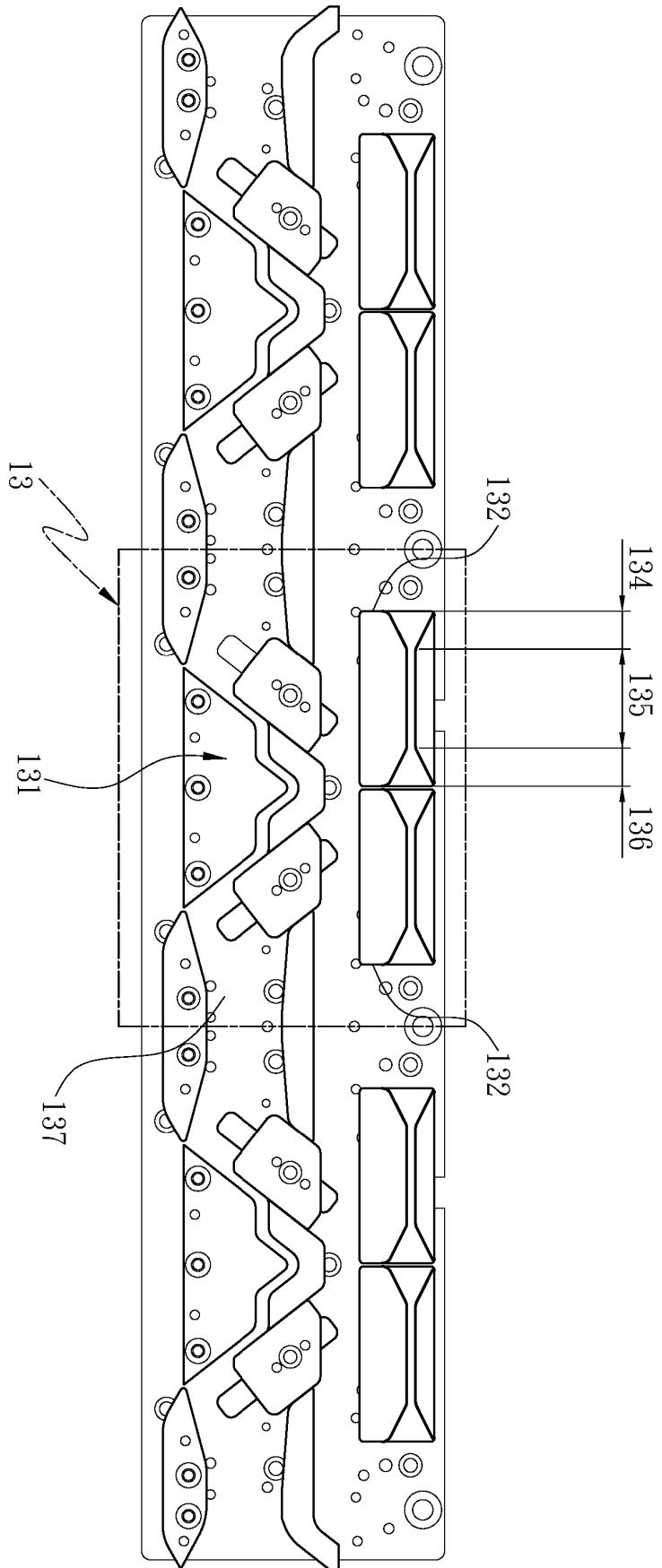

Fig. 7

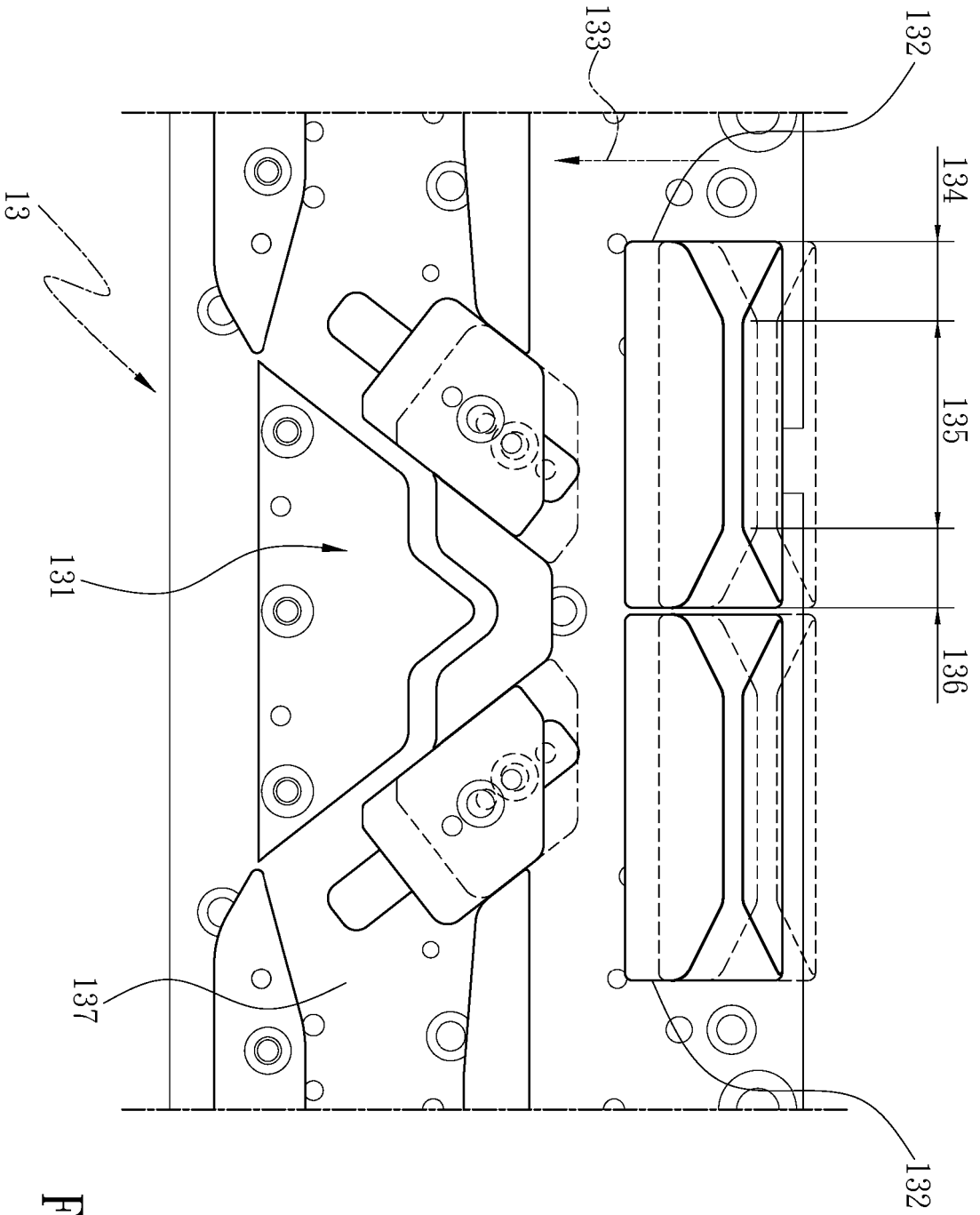

Fig. 8

90

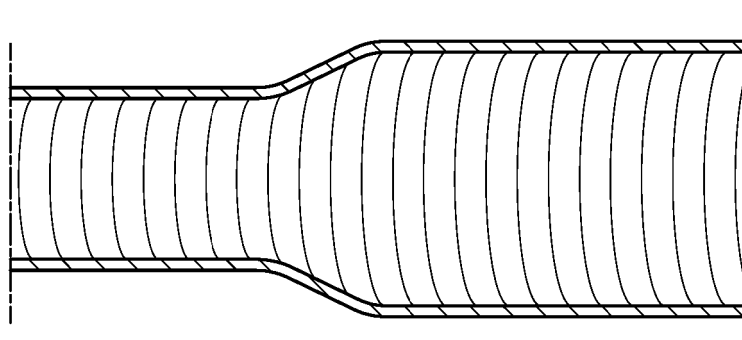

Fig. 9

REFERENCES CITED IN THE DESCRIPTION

This list of references cited by the applicant is for the reader's convenience only. It does not form part of the European patent document. Even though great care has been taken in compiling the references, errors or omissions cannot be excluded and the EPO disclaims all liability in this regard.

Patent documents cited in the description

- CN 102704180 A [0002]
- CN 102978823 A [0002]
- CN 105220347 A [0002]
- EP 1340847 A1 [0002]
- EP 0533414 A1 [0002]
- EP 1247887 A1 [0002]