



(12) **EUROPEAN PATENT APPLICATION**

(43) Date of publication:  
**23.09.2020 Bulletin 2020/39**

(51) Int Cl.:  
**A24F 47/00 (2020.01)**

(21) Application number: **19020180.6**

(22) Date of filing: **22.03.2019**

(84) Designated Contracting States:  
**AL AT BE BG CH CY CZ DE DK EE ES FI FR GB GR HR HU IE IS IT LI LT LU LV MC MK MT NL NO PL PT RO RS SE SI SK SM TR**  
 Designated Extension States:  
**BA ME**  
 Designated Validation States:  
**KH MA MD TN**

(71) Applicant: **NERUDIA LIMITED**  
**Liverpool Merseyside L24 9HP (GB)**

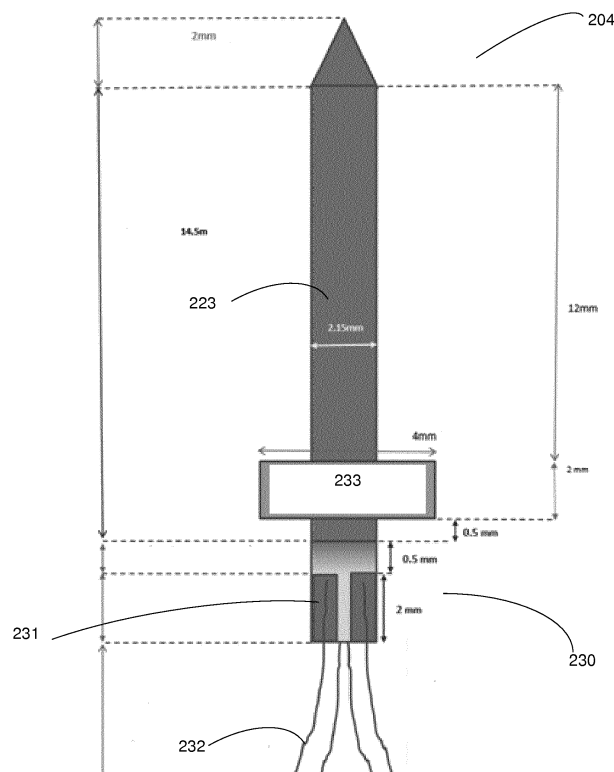
(72) Inventor: **The designation of the inventor has not yet been filed**

(74) Representative: **Mewburn Ellis LLP**  
**Aurora Building**  
**Counterslip**  
**Bristol BS1 6BX (GB)**

(54) **SMOKING SUBSTITUTE SYSTEM**

(57) A smoking substitute system (100) and device including a heater. The heater includes a heating element (223) including a resistive heating track formed thereon. The heater further includes a mount (233) surrounding a portion of the heating element and the heating track. The

heating element is formed from a heater material of a first thermal conductivity and the mount is formed from a mount material of a second thermal conductivity. The second thermal conductivity is lower than the first thermal conductivity.



**FIG 3**

## Description

### TECHNICAL FIELD

[0001] The present invention relates to a smoking substitute system and particularly, although not exclusively, to a smoking substitute system comprising a heat not burn device and an aerosol-forming article.

### BACKGROUND

[0002] The smoking of tobacco is generally considered to expose a smoker to potentially harmful substances. It is generally thought that a significant amount of the potentially harmful substances are generated through the heat caused by the burning and/or combustion of the tobacco and the constituents of the burnt tobacco in the tobacco smoke itself.

[0003] Conventional combustible smoking articles, such as cigarettes, typically comprise a cylindrical rod of tobacco comprising shreds of tobacco which is surrounded by a wrapper, and usually also a cylindrical filter axially aligned in an abutting relationship with the wrapped tobacco rod. The filter typically comprises a filtration material which is circumscribed by a plug wrap. The wrapped tobacco rod and the filter are joined together by a wrapped band of tipping paper that circumscribes the entire length of the filter and an adjacent portion of the wrapped tobacco rod. A conventional cigarette of this type is used by lighting the end opposite to the filter, and burning the tobacco rod. The smoker receives mainstream smoke into their mouth by drawing on the mouth end or filter end of the cigarette.

[0004] Combustion of organic material such as tobacco is known to produce tar and other potentially harmful by-products. There have been proposed various smoking substitute systems (or "substitute smoking systems") in order to avoid the smoking of tobacco.

[0005] Such smoking substitute systems can form part of nicotine replacement therapies aimed at people who wish to stop smoking and overcome a dependence on nicotine.

[0006] Smoking substitute systems include electronic systems that permit a user to simulate the act of smoking by producing an aerosol (also referred to as a "vapour") that is drawn into the lungs through the mouth (inhaled) and then exhaled. The inhaled aerosol typically bears nicotine and/or flavourings without, or with fewer of, the odour and health risks associated with traditional smoking.

[0007] In general, smoking substitute systems are intended to provide a substitute for the rituals of smoking, whilst providing the user with a similar experience and satisfaction to those experienced with traditional smoking and with combustible tobacco products. Some smoking substitute systems use smoking substitute articles (also referred to as a "consumables") that are designed to resemble a traditional cigarette and are cylindrical in form

with a mouthpiece at one end.

[0008] The popularity and use of smoking substitute systems has grown rapidly in the past few years. Although originally marketed as an aid to assist habitual smokers wishing to quit tobacco smoking, consumers are increasingly viewing smoking substitute systems as desirable lifestyle accessories.

[0009] There are a number of different categories of smoking substitute systems, each utilising a different smoking substitute approach.

[0010] One approach for a smoking substitute system is the so-called Heated Tobacco ("HT") approach in which tobacco (rather than an "e-liquid") is heated or warmed to release vapour. HT is also known as "heat not burn" ("HNB"). The tobacco may be leaf tobacco or reconstituted tobacco. The vapour may contain nicotine and/or flavourings. In the HT approach the intention is that the tobacco is heated but not burned, i.e. the tobacco does not undergo combustion.

[0011] A typical HT smoking substitute system may include a device and consumable. The consumable may include the tobacco material. The device and consumable may be configured to be physically coupled together. In use, heat may be imparted to the tobacco material by a heating element of the device, wherein airflow through the tobacco material causes components in the tobacco material to be released as vapour. A vapour may also be formed from a carrier in the tobacco material (this carrier may for example include propylene glycol and/or vegetable glycerine) and additionally volatile compounds released from the tobacco. The released vapour may be entrained in the airflow drawn through the tobacco.

[0012] As the vapour passes through the consumable (entrained in the airflow) from the location of vaporisation to an outlet of the consumable (e.g. a mouthpiece), the vapour cools and condenses to form an aerosol for inhalation by the user. The aerosol will normally contain the volatile compounds.

[0013] In HT smoking substitute systems, heating as opposed to burning the tobacco material is believed to cause fewer, or smaller quantities, of the more harmful compounds ordinarily produced during smoking. Consequently, the HT approach may reduce the odour and/or health risks that can arise through the burning, combustion and pyrolytic degradation of tobacco.

[0014] There may be a need for improved design of smoking substitute systems, in particular HT smoking substitute systems, to enhance the user experience and improve the function of the HT smoking substitute system.

[0015] The present disclosure has been devised in the light of the above considerations.

### SUMMARY OF THE INVENTION

[0016] At its most general, the present invention relates to a heat not burn device.

[0017] According to a first aspect of the present inven-

tion, there is provided heater for a heat not burn device. The heater includes a longitudinal heating element including a resistive heating track formed thereon. The heater further includes a mount surrounding a portion of the heating element and the heating track. The heating element is formed from a heater material of a first thermal conductivity and the mount is formed from a mount material of a second thermal conductivity. The second thermal conductivity is lower than the first thermal conductivity.

**[0018]** By providing a heat not burn device comprising a heater having a mount formed from a material having lower thermal conductivity than the material of the heating element, the device may be enabled to contain the heat where it most needed. i.e., in the region where the heating element is located and minimize losses in heat.

**[0019]** Optional features will now be set out. These are applicable singly or in any combination with any aspect.

**[0020]** Advantageously, the first thermal conductivity is at least 3 times greater than the second thermal conductivity, preferably 6 times, more preferably 10 times greater or more than the second thermal conductivity. Thereby more heat is imparted and kept in the region where it is needed with less losses in heat.

**[0021]** Optionally, the longitudinal heating element is configured to penetrate the tobacco portion of a consumable engaged with the device.

**[0022]** Advantageously, the heater material is alumina, thereby improving the hardness of the rod heater.

**[0023]** Conveniently, the mount material is zirconia, thereby improving the longevity of the mount.

**[0024]** Optionally, the resistivity of the heating track is substantially uniform along a portion of the longitudinal heating element extending between the mount and a heating region of the longitudinal heating element. This enables uniform heat distribution to the aerosol forming substrate.

**[0025]** Conveniently, the mount extends longitudinally along the heating element by a distance of between 1 and 4mm.

**[0026]** Optionally, the longitudinal heating element is located within a passage through the mount.

**[0027]** Optionally, the heater includes connection means connected to the heater track at a contact location.

**[0028]** Optionally, the contact location is on an opposite side of the mount to the heating portion of the heater.

**[0029]** Optionally, the mount is connected to the device.

**[0030]** Advantageously, the mount is bonded to the device.

**[0031]** The device may comprise an elongate body. An end of the elongate body may be configured for engagement with an aerosol-forming article. For example, the body may be configured for engagement with a heated tobacco (HT) consumable (or heat-not-burn (HNB) consumable). The terms "heated tobacco" and "heat-not-burn" are used interchangeably herein to describe a consumable that is of the type that is heated rather than

combusted (or are used interchangeably to describe a device for use with such a consumable). The device may comprise a cavity that is configured for receipt of at least a portion of the consumable (i.e. for engagement with the consumable). The aerosol-forming article may be of the type that comprises an aerosol former (e.g. carried by an aerosol-forming substrate).

**[0032]** The device may comprise a heater for heating the aerosol-forming article. The heater may comprise a heating element, which may be in the form of a rod that extends from the body of the device. The heating element may extend from the end of the body that is configured for engagement with the aerosol-forming article.

**[0033]** The heater (and thus the heating element) may be rigidly mounted to the body. The heating element may be elongate so as to define a longitudinal axis and may, for example, have a transverse profile (i.e. transverse to a longitudinal axis of the heating element) that is substantially circular (i.e. the heating element may be generally cylindrical). Alternatively, the heating element may have a transverse profile that is rectangular (i.e. the heater may be a "blade heater"). The heating element may alternatively be in the shape of a tube (i.e. the heater may be a "tube heater"). The heating element may take other forms (e.g. the heating element may have an elliptical transverse profile). The shape and/or size (e.g. diameter) of the transverse profile of the heating element may be generally consistent for the entire length (or substantially the entire length) of the heating element.

**[0034]** The heating element may be between 15 mm and 25 mm long, e.g. between 18 mm and 20 mm long, e.g. around 19 mm long. The heating element may have a diameter of between 1.5 mm and 2.5 mm, e.g. a diameter between 2 mm and 2.3 mm, e.g. a diameter of around 2.15 mm.

**[0035]** The heating element may be formed of ceramic. The heating element may comprise a core (e.g. a ceramic core) comprising Al<sub>2</sub>O<sub>3</sub>. The core of the heating element may have a diameter of 1.8 mm to 2.1 mm, e.g. between 1.9 mm and 2 mm. The heating element may comprise an outer layer (e.g. an outer ceramic layer) comprising Al<sub>2</sub>O<sub>3</sub>. The thickness of the outer layer may be between 160 μm and 220 μm, e.g. between 170 μm and 190 μm, e.g. around 180 μm. The heating element may comprise a heating track, which may extend longitudinally along the heating element. The heating track may be sandwiched between the outer layer and the core of the heating element. The heating track may comprise tungsten and/or rhenium. The heating track may have a thickness of around 20 μm.

**[0036]** The heating element may be located in the cavity (of the device), and may extend (e.g. along a longitudinal axis) from an internal base of the cavity towards an opening of the cavity. The length of the heating element (i.e. along the longitudinal axis of the heater) may be less than the depth of the cavity. Hence, the heating element may extend for only a portion of the length of the cavity. That is, the heating element may not extend through (or

beyond) the opening of the cavity.

**[0037]** The heating element may be configured for insertion into an aerosol-forming article (e.g. a HT consumable) when an aerosol-forming article is received in the cavity. In that respect, a distal end (i.e. distal from a base of the heating element where it is mounted to the device) of the heating element may comprise a tapered portion, which may facilitate insertion of the heating element into the aerosol-forming article. The heating element may fully penetrate an aerosol-forming article when the aerosol-forming article is received in the cavity. That is, the entire length, or substantially the entire length, of the heating element may be received in the aerosol-forming article.

**[0038]** The heating element may have a length that is less than, or substantially the same as, an axial length of an aerosol-forming substrate forming part of an aerosol-forming article (e.g. a HT consumable). Thus, when such an aerosol-forming article is engaged with the device, the heating element may only penetrate the aerosol-forming substrate, rather than other components of the aerosol-forming article. The heating element may penetrate the aerosol-forming substrate for substantially the entire axial length of the aerosol-forming-substrate of the aerosol-forming article. Thus, heat may be transferred from (e.g. an outer circumferential surface of) the heating element to the surrounding aerosol-forming substrate, when penetrated by the heating element. That is, heat may be transferred radially outwardly (in the case of a cylindrical heating element) or e.g. radially inwardly (in the case of a tube heater).

**[0039]** Where the heater is a tube heater, the heating element of the tube heater may surround at least a portion of the cavity. When the portion of the aerosol-forming article is received in the cavity, the heating element may surround a portion of the aerosol-forming article (i.e. so as to heat that portion of the aerosol-forming article). In particular, the heating element may surround an aerosol-forming substrate of the aerosol-forming article. That is, when an aerosol-forming article is engaged with the device, the aerosol-forming substrate of the aerosol-forming article may be located adjacent an inner surface of the (tubular) heating element. When the heating element is activated, heat may be transferred radially inwardly from the inner surface of the heating element to heat the aerosol-forming substrate.

**[0040]** In one embodiment, the heater includes a longitudinal heating element including a resistive heating track formed thereon. The heater further includes a mount surrounding a portion of the heating element and the heating track. The heating element is formed from a heater material of a first thermal conductivity and the mount is formed from a mount material of a second thermal conductivity. The second thermal conductivity is at least 3 times lower than the first thermal conductivity. The longitudinal heating element is configured to penetrate the tobacco portion of a consumable engaged with the device. Optionally, the heater material may be alumina and the mount material may be zirconia. The resis-

tivity of the heating track is substantially uniform along a portion of the longitudinal heating element extending between the mount and a heating region of the longitudinal heating element. The mount may extend longitudinally along the heating element by a distance of between 1 and 4mm and the longitudinal heating element may be located within a passage through the mount. The heater may include connection means connected to the heater track at a contact location. The contact location is on an opposite side of the mount to the heating portion of the heater.

**[0041]** Providing a mount with in accordance with the present disclosure may provide an improvement of the the hardness of the rod heater mounting plate for a heated tobacco device, an improvement of the longevity of the mounting plate for the heater device, and the thermal characteristics of the heated tobacco device in general. Isolation of other parts of the overall device from the heated part of the rod heater may be increased, and thus the heat impact on other parts reduced. Further, reflection of heat back to the heated area of the rod heater may result in less heat needed to keep the rod heater and overall device at temperature. Mounting material made out of zirconia may be used as a mounting base as well as a thermal shield for rod heater. Because zirconia has a thermal conductivity which is a fraction of that e.g. for alumina or other material of which the rod heating element is made of, much of the heat produced by the rod heater in the region near the zirconia base is reflected back into the heater. The zirconia material surrounds the rod heater preferably in a cylindrical structure. Mounting and longevity of usage are facilitated owing to the high hardness of the zirconia. The shape of the zirconia base may be square or round and may have a thickness, which extends along the rod heater. The thickness of the zirconia plate may preferably be at least 1 mm.

**[0042]** Mounting and longevity of usage are facilitated owing to the high hardness of the zirconia. The shape of the zirconia base can be square or round and has a thickness which extends along the rod heater (cylindrical shape). The thickness of the zirconia plate is at least 1mm.

**[0043]** The cavity may comprise a (e.g. circumferential) wall (or walls) and the (tubular) heating element may extend around at least a portion of the wall(s). In this way, the wall may be located between the inner surface of the heating element and an outer surface of the aerosol-forming article. The wall (or walls) of the cavity may be formed from a thermally conductive material (e.g. a metal) to allow heat conduction from the heating element to the aerosol-forming article. Thus, heat may be conducted from the heating element, through the cavity wall (or walls), to the aerosol-forming substrate of an aerosol-forming article received in the cavity.

**[0044]** In some embodiments the device may comprise a cap disposed at the end of the body that is configured for engagement with an aerosol-forming article. Where the device comprises a heater having a heating element,

the cap may at least partially enclose the heating element. The cap may be moveable between an open position in which access is provided to the heating element, and a closed position in which the cap at least partially encloses the heating element. The cap may be slideably engaged with the body of the device, and may be slideable between the open and closed positions.

**[0045]** The cap may define at least a portion of the cavity of the device. That is, the cavity may be fully defined by the cap, or each of the cap and body may define a portion of the cavity. Where the cap fully defines the cavity, the cap may comprise an aperture for receipt of the heating element into the cavity (when the cap is in the closed position). The cap may comprise an opening to the cavity. The opening may be configured for receipt of at least a portion of an aerosol-forming article. That is, an aerosol-forming article may be inserted through the opening and into the cavity (so as to be engaged with the device).

**[0046]** The cap may be configured such that when an aerosol-forming article is engaged with the device (e.g. received in the cavity), only a portion of the aerosol-forming article is received in the cavity. That is, a portion of the aerosol-forming article (not received in the cavity) may protrude from (i.e. extend beyond) the opening. This (protruding) portion of the aerosol-forming article may be a terminal (e.g. mouth) end of the aerosol-forming article, which may be received in a user's mouth for the purpose of inhaling aerosol formed by the device.

**[0047]** The device may comprise a power source or may be connectable to a power source (e.g. a power source separate to the device). The power source may be electrically connectable to the heater. In that respect, altering (e.g. toggling) the electrical connection of the power source to the heater may affect a state of the heater. For example, toggling the electrical connection of the power source to the heater may toggle the heater between an on state and an off state. The power source may be a power store. For example, the power source may be a battery or rechargeable battery (e.g. a lithium ion battery).

**[0048]** The device may comprise an input connection (e.g. a USB port, Micro USB port, USB-C port, etc.). The input connection may be configured for connection to an external source of electrical power, such as a mains electrical supply outlet. The input connection may, in some cases, be used as a substitute for an internal power source (e.g. battery or rechargeable battery). That is, the input connection may be electrically connectable to the heater (for providing power to the heater). Hence, in some forms, the input connection may form at least part of the power source of the device

**[0049]** Where the power source comprises a rechargeable power source (such as a rechargeable battery), the input connection may be used to charge and recharge the power source.

**[0050]** The device may comprise a user interface (UI). In some embodiments the UI may include input means

to receive operative commands from the user. The input means of the UI may allow the user to control at least one aspect of the operation of the device. In some embodiments the input means may comprise a power button to switch the device between an on state and an off state.

**[0051]** In some embodiments the UI may additionally or alternatively comprise output means to convey information to the user. In some embodiments the output means may comprise a light to indicate a condition of the device (and/or the aerosol-forming article) to the user. The condition of the device (and/or aerosol-forming article) indicated to the user may comprise a condition indicative of the operation of the heater. For example, the condition may comprise whether the heater is in an off state or an on state. In some embodiments, the UI unit may comprise at least one of a button, a display, a touchscreen, a switch, a light, and the like. For example, the output means may comprise one or more (e.g. two, three, four, etc.) light-emitting diodes ("LEDs") that may be located on the body of the device.

**[0052]** The device may further comprise a puff sensor (e.g. airflow sensor), which form part of the input means of the UI. The puff sensor may be configured to detect a user drawing on an end (i.e. a terminal (mouth) end) of the aerosol-forming article. The puff sensor may, for example, be a pressure sensor or a microphone. The puff sensor may be configured to produce a signal indicative of a puff state. The signal may be indicative of the user drawing (an aerosol from the aerosol-forming article) such that it is e.g. in the form of a binary signal. Alternatively, or additionally, the signal may be indicative of a characteristic of the draw (e.g. a flow rate of the draw, length of time of the draw, etc).

**[0053]** The device may comprise a controller, or may be connectable to a controller that may be configured to control at least one function of the device. The controller may comprise a microcontroller that may e.g. be mounted on a printed circuit board (PCB). The controller may also comprise a memory, e.g. non-volatile memory. The memory may include instructions, which, when implemented, may cause the controller to perform certain tasks or steps of a method. Where the device comprises an input connection, the controller may be connected to the input connection.

**[0054]** The controller may be configured to control the operation of the heater (and e.g. the heating element). Thus, the controller may be configured to control vapourisation of an aerosol forming part of an aerosol-forming article engaged with the device. The controller may be configured to control the voltage applied by power source to the heater. For example, the controller may be configured to toggle between applying a full output voltage (of the power source) to the heater and applying no voltage to the heater. Alternatively, or additionally, the control unit may implement a more complex heater control protocol.

**[0055]** The device may further comprise a voltage regulator to regulate the output voltage supplied by the pow-

er source to form a regulated voltage. The regulated voltage may subsequently be applied to the heater.

**[0056]** In some embodiments, where the device comprises a UI, the controller may be operatively connected to one or more components of the UI. The controller may be configured to receive command signals from an input means of the UI. The controller may be configured to control the heater in response to the command signals. For example, the controller may be configured to receive "on" and "off" command signals from the UI and, in response, may control the heater so as to be in a corresponding on or off state.

**[0057]** The controller may be configured to send output signals to a component of the UI. The UI may be configured to convey information to a user, via an output means, in response to such output signals (received from the controller). For example, where the device comprises one or more LEDs, the LEDs may be operatively connected to the controller. Hence, the controller may be configured to control the illumination of the LEDs (e.g. in response to an output signal). For example, the controller may be configured to control the illumination of the LEDs according to (e.g. an on or off) state of the heater.

**[0058]** Where the device comprises a sensor (e.g. a puff/airflow sensor), the controller may be operatively connected to the sensor. The controller may be configured to receive a signal from the sensor (e.g. indicative of a condition of the device and/or engaged aerosol-forming article). The controller may be configured to control the heater, or an aspect of the output means, based on the signal from the sensor.

**[0059]** The device may comprise a wireless interface configured to communicate wirelessly (e.g. via Bluetooth (e.g. a Bluetooth low-energy connection) or WiFi) with an external device. Similarly, the input connection may be configured for wired connection to an external device so as to provide communication between the device and the external device.

**[0060]** The external device may be a mobile device. For example, the external device may be a smart phone, tablet, smart watch, or smart car. An application (e.g. app) may be installed on the external device (e.g. mobile device). The application may facilitate communication between the device and the external device via the wired or wireless connection.

**[0061]** The wireless or wired interface may be configured to transfer signals between the external device and the controller of the device. In this respect, the controller may control an aspect of the device in response to a signal received from an external device. Alternatively, or additionally, an external device may respond to a signal received from the device (e.g. from the controller of the device).

**[0062]** In a second aspect, there is provided a system (e.g. a smoking substitute system) comprising a heating not burn device according to the present disclosure and an aerosol-forming article. The aerosol-forming article may comprise an aerosol-forming substrate at an up-

stream end of the aerosol-forming article. The article may be in the form of a smoking substitute article, e.g. heated tobacco (HT) consumable (also known as a heat-not-burn (HNB) consumable).

**[0063]** As used herein, the terms "upstream" and "downstream" are intended to refer to the flow direction of the vapour/aerosol i.e. with the downstream end of the article/consumable being the mouth end or outlet where the aerosol exits the consumable for inhalation by the user. The upstream end of the article/consumable is the opposing end to the downstream end.

**[0064]** The aerosol-forming substrate is capable of being heated to release at least one volatile compound that can form an aerosol. The aerosol-forming substrate may be located at the upstream end of the article/consumable.

**[0065]** In order to generate an aerosol, the aerosol-forming substrate comprises at least one volatile compound that is intended to be vaporised/aerosolised and that may provide the user with a recreational and/or medicinal effect when inhaled. Suitable chemical and/or physiologically active volatile compounds include the group consisting of: nicotine, cocaine, caffeine, opiates and opioids, cathine and cathinone, kavalactones, mysticin, beta-carboline alkaloids, salvinorin A together with any combinations, functional equivalents to, and/or synthetic alternatives of the foregoing.

**[0066]** The aerosol-forming substrate may comprise plant material. The plant material may comprise least one plant material selected from the list including *Amaranthus dubius*, *Arctostaphylos uva-ursi* (Bearberry), *Argemone mexicana*, *Amica*, *Artemisia vulgaris*, Yellow Tees, *Galea zacatechichi*, *Canavalia maritima* (Baybean), *Cecropia mexicana* (Guamura), *Cestrum nocturnum*, *Cynoglossum virginianum* (wild comfrey), *Cytisus scoparius*, *Damiana*, *Entada rheedii*, *Eschscholzia californica* (California Poppy), *Fittonia albivenis*, *Hippobroma longiflora*, *Humulus japonica* (Japanese Hops), *Humulus lupulus* (Hops), *Lactuca virosa* (Lettuce Opium), *Lagdera alata*, *Leonotis leonurus*, *Leonurus cardiaca* (Motherwort), *Leonurus sibiricus* (Honeyweed), *Lobelia cardinalis*, *Lobelia inflata* (Indian-tobacco), *Lobelia siphilitica*, *Nepeta cataria* (Catnip), *Nicotiana species* (Tobacco), *Nymphaea alba* (White Lily), *Nymphaea caerulea* (Blue Lily), Opium poppy, *Passiflora incarnata* (Passionflower), *Pedicularis densiflora* (Indian Warrior), *Pedicularis groenlandica* (Elephant's Head), *Salvia divinorum*, *Salvia dorrii* (Tobacco Sage), *Salvia species* (Sage), *Scutellaria galericulata*, *Scutellaria lateriflora*, *Scutellaria nana*, *Scutellaria species* (Skullcap), *Sida acuta* (Wireweed), *Sida rhombifolia*, *Silene capensis*, *Syzygium aromaticum* (Clove), *Tagetes lucida* (Mexican Tarragon), *Tarhonanthus camphoratus*, *Tumera diffusa* (Damiana), *Verbascum* (Mullein), *Zamia latifolia* (Maconha Brava) together with any combinations, functional equivalents to, and/or synthetic alternatives of the foregoing.

**[0067]** The plant material may be tobacco. Any type of tobacco may be used. This includes, but is not limited to, flue-cured tobacco, burley tobacco, Maryland Tobacco,

dark-air cured tobacco, oriental tobacco, dark-fired tobacco, perique tobacco and rustica tobacco. This also includes blends of the above mentioned tobaccos.

**[0068]** The tobacco may comprise one or more of leaf tobacco, stem tobacco, tobacco powder, tobacco dust, tobacco derivatives, expanded tobacco, homogenised tobacco, shredded tobacco, extruded tobacco, cut rag tobacco and/or reconstituted tobacco (e.g. slurry recon or paper recon).

**[0069]** The aerosol-forming substrate may comprise a gathered sheet of homogenised (e.g. paper/slurry recon) tobacco or gathered shreds/strips formed from such a sheet.

**[0070]** The aerosol-forming substrate may comprise one or more additives selected from humectants, flavourants, fillers, aqueous/non-aqueous solvents and binders.

**[0071]** The flavourant may be provided in solid or liquid form. It may include menthol, liquorice, chocolate, fruit flavour (including e.g. citrus, cherry etc.), vanilla, spice (e.g. ginger, cinnamon) and tobacco flavour. The flavourant may be evenly dispersed throughout the aerosol-forming substrate or may be provided in isolated locations and/or varying concentrations throughout the aerosol-forming substrate.

**[0072]** The aerosol-forming substrate may be formed in a substantially cylindrical shape such that the article/consumable resembles a conventional cigarette. It may have a diameter of between 5 and 10mm e.g. between 6 and 9mm or 6 and 8mm e.g. around 7 mm. It may have an axial length of between 10 and 15mm e.g. between 11 and 14mm such as around 12 or 13mm.

**[0073]** The article/consumable may comprise at least one filter element. There may be a terminal filter element at the downstream/mouth end of the article/consumable.

**[0074]** The or at least one of the filter element(s) (e.g. the terminal filter element) may be comprised of cellulose acetate or polypropylene tow. The at least one filter element (e.g. the terminal filter element) may be comprised of activated charcoal. The at least one filter element (e.g. the terminal element) may be comprised of paper. The or each filter element may be at least partly (e.g. entirely) circumscribed with a plug wrap e.g. a paper plug wrap.

**[0075]** The terminal filter element (at the downstream end of the article/consumable) may be joined to the upstream elements forming the article/consumable by a circumscribing tipping layer e.g. a tipping paper layer. The tipping paper may have an axial length longer than the axial length of the terminal filter element such that the tipping paper completely circumscribes the terminal filter element plus the wrapping layer surrounding any adjacent upstream element.

**[0076]** In some embodiments, the article/consumable may comprise an aerosol-cooling element which is adapted to cool the aerosol generated from the aerosol-forming substrate (by heat exchange) before being inhaled by the user.

**[0077]** The article/consumable may comprise a spacer element that defines a space or cavity between the aer-

osol-forming substrate and the downstream end of the consumable. The spacer element may comprise a cardboard tube. The spacer element may be circumscribed by the (paper) wrapping layer.

**[0078]** According to another aspect of the present invention, there is provided a method of using the smoking substitute system according to the second aspect, the method comprising inserting the aerosol-forming article into the device; and heating the article using the heater of the device.

**[0079]** In some embodiments the method may comprise inserting the article into a cavity within a body of the device and penetrating the article with the heating element of the device upon insertion of the article.

**[0080]** According to one more aspect of the present invention, there is provided a smoking substitute system comprising a heat not burn device including a heater in accordance with the present invention.

**[0081]** The invention includes the combination of the aspects and preferred features described except where such a combination is clearly impermissible or expressly avoided.

**[0082]** The skilled person will appreciate that except where mutually exclusive, a feature or parameter described in relation to any one of the above aspects may be applied to any other aspect. Furthermore, except where mutually exclusive, any feature or parameter described herein may be applied to any aspect and/or combined with any other feature or parameter described herein.

### **SUMMARY OF THE FIGURES**

**[0083]** So that the invention may be understood, and so that further aspects and features thereof may be appreciated, embodiments illustrating the principles of the invention will now be discussed in further detail with reference to the accompanying figures, in which:

Figure 1A is a schematic of a smoking substitute system;

Figure 1B is a schematic of a variation of the smoking substitute system of Figure 1A;

Figure 2A is a front view of a first embodiment of a smoking substitute system with the consumable engaged with the device;

Figure 2B is a front view of the first embodiment of the smoking substitute system with the consumable disengaged from the device;

Figure 2C is a section view of the consumable of the first embodiment of the smoking substitute system;

Figure 2D is a detailed view of an end of the device of the first embodiment of the smoking substitute sys-

tem;

Figure 2E is a section view of the first embodiment of the substitute smoking system;

Figure 3 illustrates a perspective view of the heater of the heat not burn device in accordance with an embodiment of the substitute smoking system;

#### **DETAILED DESCRIPTION OF THE INVENTION**

**[0084]** Aspects and embodiments of the present invention will now be discussed with reference to the accompanying figures. Further aspects and embodiments will be apparent to those skilled in the art. All documents mentioned in this text are incorporated herein by reference.

**[0085]** Figure 1A is a schematic providing a general overview of a smoking substitute system 100. The system 100 includes a substitute smoking device 101 and an aerosol-forming article in the form of a consumable 102, which comprises an aerosol former 103. The system is configured to vaporise the aerosol former by heating the aerosol former 103 (so as to form a vapour/aerosol for inhalation by a user).

**[0086]** In the illustrated system, the heater 104 forms part of the consumable 102 and is configured to heat the aerosol former 103. In this variation, the heater 104 is electrically connectable to the power source 105, for example, when the consumable 102 is engaged with the device 101. Heat from the heater 104 vaporises the aerosol former 103 to produce a vapour. The vapour subsequently condenses to form an aerosol, which is ultimately inhaled by the user.

**[0087]** The system 100 further comprises a power source 105 that forms part of the device 101. In other embodiments the power source 105 may be external to (but connectable to) the device 101. The power source 105 is electrically connectable to the heater 104 such that it is able to supply power to the heater 104 (i.e. for the purpose of heating the aerosol former 103). Thus, control of the electrical connection of the power source 105 to the heater 104 provides control of the state of the heater 104. The power source 105 may be a power store, for example a battery or rechargeable battery (e.g. a lithium ion battery).

**[0088]** The system 100 further comprises an I/O module comprising a connector 106 (e.g. in the form of a USB port, Micro USB port, USB-C port, etc.). The connector 106 is configured for connection to an external source of electrical power, e.g. a mains electrical supply outlet. The connector 106 may be used in substitution for the power source 105. That is the connector 106 may be electrically connectable to the heater 104 so as to supply electricity to the heater 104. In such embodiments, the device may not include a power source, and the power source of the system may instead comprise the connector 106 and an external source of electrical power (to which the connec-

tor 106 provides electrical connection).

**[0089]** In some embodiments, the connector 106 may be used to charge and recharge the power source 105 where the power source 105 includes a rechargeable battery.

**[0090]** The system 100 also comprises a user interface (UI) 107. Although not shown, the UI 107 may include input means to receive commands from a user. The input means of the UI 107 allows the user to control at least one aspect of the operation of the system 100. The input means may, for example, be in the form of a button, touch-screen, switch, microphone, etc.

**[0091]** The UI 107 also comprises output means to convey information to the user. The output means may, for example, comprise lights (e.g. LEDs), a display screen, speaker, vibration generator, etc.

**[0092]** The system 100 further comprises a controller 108 that is configured to control at least one function of the device 101. In the illustrated embodiment, the controller 108 is a component of the device 101, but in other embodiments may be separate from (but connectable to) the device 101. The controller 108 is configured to control the operation of the heater 104 and, for example, may be configured to control the voltage applied from the power source 105 to the heater 104. The controller 108 may be configured to toggle the supply of power to the heater 104 between an on state, in which the full output voltage of the power source 105 is applied to the heater 104, and an off state, in which the no voltage is applied to the heater 104.

**[0093]** Although not shown, the system 100 may also comprise a voltage regulator to regulate the output voltage from the power source 105 to form a regulated voltage. The regulated voltage may then be applied to the heater 104.

**[0094]** In addition to being connected to the heater 104, the controller 108 is operatively connected to the UI 107. Thus, the controller 108 may receive an input signal from the input means of the UI 107. Similarly, the controller 108 may transmit output signals to the UI 107. In response, the output means of the UI 107 may convey information, based on the output signals, to a user. The controller also comprises a memory 109, which is a non-volatile memory. The memory 109 includes instructions, which, when implemented, cause the controller to perform certain tasks or steps of a method.

**[0095]** Figure 1B is a schematic showing a variation of the system 100 of Figure 1A. In the system 100' of Figure 1B, the heater 104 forms part of the device 101, rather than the consumable 102. In this variation, the heater 104 is electrically connected to the power source 105.

**[0096]** Figures 2A and 2B illustrate a heated-tobacco (HT) smoking substitute system 200. The system 200 is an example of the systems 100, 100' described in relation to Figures 1A or 1B. System 200 includes an HT device 201 and an HT consumable 202. The description of Figures 1A and 1B above is applicable to the system 200 of Figures 2A and 2B, and will thus not be repeated.



**[0097]** The device 201 and the consumable 202 are configured such that the consumable 202 can be engaged with the device 201. Figure 2A shows the device 201 and the consumable 202 in an engaged state, whilst Figure 2B shows the device 201 and the consumable 202 in a disengaged state.

**[0098]** The device 201 comprises a body 209 and cap 210. In use the cap 210 is engaged at an end of the body 209. Although not apparent from the figures, the cap 210 is moveable relative to the body 209. In particular, the cap 210 is slideable and can slide along a longitudinal axis of the body 209.

**[0099]** The device 201 comprises an output means (forming part of the UI of the device 201) in the form of a plurality of light-emitting diodes (LEDs) 211 arranged linearly along the longitudinal axis of the device 201 and on an outer surface of the body 209 of the device 201. A button 212 is also arranged on an outer surface of the body 209 of the device 201 and is axially spaced (i.e. along the longitudinal axis) from the plurality of LEDs 211.

**[0100]** Figure 2C show a detailed section view of the consumable of 202 of the system 200. The consumable 202 generally resembles a cigarette. In that respect, the consumable 202 has a generally cylindrical form with a diameter of 7 mm and an axial length of 70 mm. The consumable 202 comprises an aerosol forming substrate 213, a terminal filter element 214, an upstream filter element 215 and a spacer element 216. In other embodiments, the consumable may further comprise a cooling element. A cooling element may exchange heat with vapour that is formed by the aerosol-forming substrate 213 in order to cool the vapour so as to facilitate condensation of the vapour.

**[0101]** The aerosol-forming substrate 213 is substantially cylindrical and is located at an upstream end 217 of the consumable 202, and comprises the aerosol former of the system 200. In that respect, the aerosol forming substrate 213 is configured to be heated by the device 201 to release a vapour. The released vapour is subsequently entrained in an airflow flowing through the aerosol-forming substrate 213. The airflow is produced by the action of the user drawing on a downstream 218 (i.e. terminal or mouth) end of the consumable 202.

**[0102]** In the present embodiment, the aerosol forming substrate 213 comprises tobacco material that may, for example, include any suitable parts of the tobacco plant (e.g. leaves, stems, roots, bark, seeds and flowers). The tobacco may comprise one or more of leaf tobacco, stem tobacco, tobacco powder, tobacco dust, tobacco derivatives, expanded tobacco, homogenised tobacco, shredded tobacco, extruded tobacco, cut rag tobacco and/or reconstituted tobacco (e.g. slurry recon or paper recon). For example, the aerosol-forming substrate 213 may comprise a gathered sheet of homogenised (e.g. paper/slurry recon) tobacco or gathered shreds/strips formed from such a sheet.

**[0103]** In order to generate an aerosol, the aerosol forming substrate 213 comprises at least one volatile

compound that is intended to be vaporised/aerosolised and that may provide the user with a recreational and/or medicinal effect when inhaled. The aerosol-forming substrate 213 may further comprise one or more additives. For example, such additives may be in the form of humectants (e.g. propylene glycol and/or vegetable glycerine), flavourants, fillers, aqueous/non-aqueous solvents and/or binders.

**[0104]** The terminal filter element 214 is also substantially cylindrical and is located downstream of the aerosol forming substrate 213 at the downstream end 218 of the consumable 202. The terminal filter element 214 is in the form of a hollow bore filter element having a bore 219 (e.g. for airflow) formed therethrough. The diameter of the bore 219 is 2 mm. The terminal filter element 214 is formed of a porous (e.g. monoacetate) filter material. As set forth above, the downstream end 218 of the consumable 202 (i.e. where the terminal filter 214 is located) forms a mouthpiece portion of the consumable 202 upon which the user draws. Airflow is drawn from the upstream end 217, through the components of the consumable 202, and out of the downstream end 218. The airflow is driven by the user drawing on the downstream end 218 (i.e. the mouthpiece portion) of the consumable 202.

**[0105]** The upstream filter element 215 is located axially adjacent to the aerosol-forming substrate 213, between the aerosol-forming substrate 213 and the terminal filter element 214. Like the terminal filter 214, the upstream filter element 215 is in the form of a hollow bore filter element, such that it has a bore 220 extending axially therethrough. In this way, the upstream filter 215 may act as an airflow restrictor. The upstream filter element 215 is formed of a porous (e.g. monoacetate) filter material. The bore 220 of the upstream filter element 215 has a larger diameter (3 mm) than the terminal filter element 214.

**[0106]** The spacer 216 is in the form of a cardboard tube, which defines a cavity or chamber between the upstream filter element 215 and the terminal filter element 214. The spacer 216 acts to allow both cooling and mixing of the vapour/aerosol from the aerosol-forming substrate 213. The spacer has an external diameter of 7 mm and an axial length of 14mm.

**[0107]** Although not apparent from the figure, the aerosol-forming substrate 213, upstream filter 215 and spacer 216 are circumscribed by a paper wrapping layer. The terminal filter 214 is circumscribed by a tipping layer that also circumscribes a portion of the paper wrapping layer (so as to connect the terminal filter 214 to the remaining components of the consumable 202). The upstream filter 215 and terminal filter 214 are circumscribed by further wrapping layers in the form of plug wraps.

**[0108]** Returning now to the device 201, Figure 2D illustrates a detailed view of the end of the device 201 that is configured to engage with the consumable 202. The cap 210 of the device 201 includes an opening 221 to an internal cavity 222 (more apparent from Figure 2D) defined by the cap 210. The opening 221 and the cavity

222 are formed so as to receive at least a portion of the consumable 202. During engagement of the consumable 202 with the device 201, a portion of the consumable 202 is received through the opening 221 and into the cavity 222. After engagement (see Figure 2B), the downstream end 218 of the consumable 202 protrudes from the opening 221 and thus also protrudes from the device 201. The opening 221 includes laterally disposed notches 226. When a consumable 202 is received in the opening 221, these notches 226 remain open and could, for example, be used for retaining a cover in order to cover the end of the device 201.

**[0109]** Figure 2E shows a cross section through a central longitudinal plane through the device 201. The device 201 is shown with the consumable 202 engaged therewith.

**[0110]** The device 201 comprises a heater 204 comprising heating element 223. The heater 204 forms part of the body 209 of the device 201 and is rigidly mounted to the body 209. In the illustrated embodiment, the heater 204 is a rod heater with a heating element 223 having a circular transverse profile. In other embodiments the heater may be in the form of a blade heater (e.g. heating element with a rectangular transverse profile) or a tube heater (e.g. heating element with a tubular form).

**[0111]** The heating element 223 of the heater 204 projects from an internal base of the cavity 222 along a longitudinal axis towards the opening 221. As is apparent from the figure, the length (i.e. along the longitudinal axis) of the heating element is less than a depth of the cavity 222. In this way, the heating element 223 does not protrude from or extend beyond the opening 221.

**[0112]** When the consumable 202 is received in the cavity 222 (as is shown in Figure 2E), the heating element 223 penetrates the aerosol-forming substrate 213 of the consumable 202. In particular, the heating element 223 extends for nearly the entire axial length of the aerosol-forming substrate 213 when inserted therein. Thus, when the heater 204 is activated, heat is transferred radially from an outer circumferential surface the heating element 223 to the aerosol-forming substrate 213.

**[0113]** In an embodiment, as shown in Figure 3, the heating element 223 of the heater 204 has a substantially longitudinal configuration. The longitudinal heating element 223 includes a resistive heating track formed thereon. The heating track may be configured with a power source of the device 201 to supply heat to the aerosol forming substrate 213 of the consumable 202. The heating element 223 has a proximal end and a distal end. The heater 204 is mounted to the device 201 in the vicinity of the internal base of the cavity 222 at the proximal end. The heating track may be connected to the power source at a contact location 230 formed at the proximal end of the heating element 223 through connecting means. The contact location 230 comprises connection means such as, but not limited to, connecting pads 231 connected to the power source through electrical wires 232. In a non-limiting embodiment, the connection zone extends up to

a length of 2mm of the heating element 223 from the base. The heating element 223 further includes a tapered tip or a conical tip for penetrating the consumable 202 when received in the cavity 222. The tapered tip 223B is located at the distal end of the heating element 223. The heating element 223 is formed from a heater material having a first thermal conductivity. In one aspect, the heating element has a width of 2.15mm.

**[0114]** The heater 204 further includes a mount 233 that surrounds at least a portion of the heating element 223 and the heating track in the vicinity of the proximal end of the heating element 223. The mount 233 is formed from a mount material having a second thermal conductivity, with the second thermal conductivity being at least 3 times lower than the first thermal conductivity. In a preferred embodiment, the second thermal conductivity is 6 times lower than the first thermal conductivity. In a more preferred embodiment, the second thermal conductivity is 10 times lower than the first thermal conductivity. The heater material may be alumina and the mount material may be zirconia. Zirconia material used can be 10 times less heat conductive than Alumina, thereby more heat is imparted and kept in the region where it is needed with less losses in heat. This in turn leads to more efficient heating and lower power consumption. Generally, the region where heat is needed the most is a portion defined along a length of the heating element 223 between the mount 233 and the conical tip. In a non-limiting embodiment, the said portion is 12mm in length and the conical tip has a height of 2mm. The resistivity of the heating track is substantially uniform along the said portion of the longitudinal heating element 223 and the tip.

**[0115]** In a non-limiting embodiment, the mount 233 extends longitudinally along the heating element 223 by a distance between 1 and 4mm. In a preferred embodiment, a buffer region of 0.5mm to 1mm may be defined between the connection zone and the mount 233. The mount 233 may have a width more than the width of the heating element 223. In a preferred embodiment, the mount 233 has a width of 4mm and a length of 2mm along a longitudinal axis of the heating element 223. In one aspect, the mount 233 comprises a passage through which the heating element 223 extends such that the contact location 230 is on an opposite side of the mount 233 with respect to the heating portion of the heater 204.

**[0116]** In a preferred embodiment, the mount 233 is connected to the device. The mount 233 may be bonded to the device 201 through mechanical means.

#### Detailed description: Power source of HT device

**[0117]** The device 201 further comprises an electronics cavity 224. A power source, in the form of a rechargeable battery 205 (a lithium ion battery), is located in electronics cavity 224.

**[0118]** The device 201 includes a connector (i.e. forming part of an IO module of the device 201) in the form of a USB port 206. The connector may alternatively be,

for example, a micro-USB port or a USB-C port for examples. The USB port 206 may be used to recharge the rechargeable battery 205.

**[0119]** The device 201 includes a controller (not shown) located in the electronics cavity 224. The controller comprises a microcontroller mounted on a printed circuit board (PCB). The USB port 206 is also connected to the controller 208 (i.e. connected to the PCB and microcontroller).

**[0120]** The controller 208 is configured to control at least one function of the device 202. For example, the controller 208 is configured to control the operation of the heater 204. Such control of the operation of the heater 204 may be accomplished by the controller toggling the electrical connection of the rechargeable battery 205 to the heater 204. For example, the controller 208 is configured to control the heater 204 in response to a user depressing the button 212. Depressing the button 212 may cause the controller to allow a voltage (from the rechargeable battery 205) to be applied to the heater 204 (so as to cause the heating element 223 to be heated).

**[0121]** The controller is also configured to control the LEDs 211 in response to (e.g. a detected) a condition of the device 201 or the consumable 202. For example, the controller may control the LEDs to indicate whether the device 201 is in an on state or an off state (e.g. one or more of the LEDs may be illuminated by the controller when the device is in an on state).

**[0122]** The device 201 comprises a further input means (i.e. in addition to the button 212) in the form of a puff sensor 225. The puff sensor 225 is configured to detect a user drawing (i.e. inhaling) at the downstream end 218 of the consumable 202. The puff sensor 225 may, for example, be in the form of a pressure sensor, flowmeter or a microphone. The puff sensor 225 is operatively connected to the controller 208 in the electronics cavity 224, such that a signal from the puff sensor 225, indicative of a puff state (i.e. drawing or not drawing), forms an input to the controller 208 (and can thus be responded to by the controller 208).

**[0123]** The features disclosed in the foregoing description, or in the following claims, or in the accompanying drawings, expressed in their specific forms or in terms of a means for performing the disclosed function, or a method or process for obtaining the disclosed results, as appropriate, may, separately, or in any combination of such features, be utilised for realising the invention in diverse forms thereof.

**[0124]** While the invention has been described in conjunction with the exemplary embodiments described above, many equivalent modifications and variations will be apparent to those skilled in the art when given this disclosure. Accordingly, the exemplary embodiments of the invention set forth above are considered to be illustrative and not limiting. Various changes to the described embodiments may be made without departing from the spirit and scope of the invention.

**[0125]** For the avoidance of any doubt, any theoretical

explanations provided herein are provided for the purposes of improving the understanding of a reader. The inventors do not wish to be bound by any of these theoretical explanations.

**[0126]** Any section headings used herein are for organizational purposes only and are not to be construed as limiting the subject matter described.

**[0127]** Throughout this specification, including the claims which follow, unless the context requires otherwise, the words "have", "comprise", and "include", and variations such as "having", "comprises", "comprising", and "including" will be understood to imply the inclusion of a stated integer or step or group of integers or steps but not the exclusion of any other integer or step or group of integers or steps.

**[0128]** It must be noted that, as used in the specification and the appended claims, the singular forms "a," "an," and "the" include plural referents unless the context clearly dictates otherwise. Ranges may be expressed herein as from "about" one particular value, and/or to "about" another particular value. When such a range is expressed, another embodiment includes from the one particular value and/or to the other particular value. Similarly, when values are expressed as approximations, by the use of the antecedent "about," it will be understood that the particular value forms another embodiment. The term "about" in relation to a numerical value is optional and means, for example, +/- 10%.

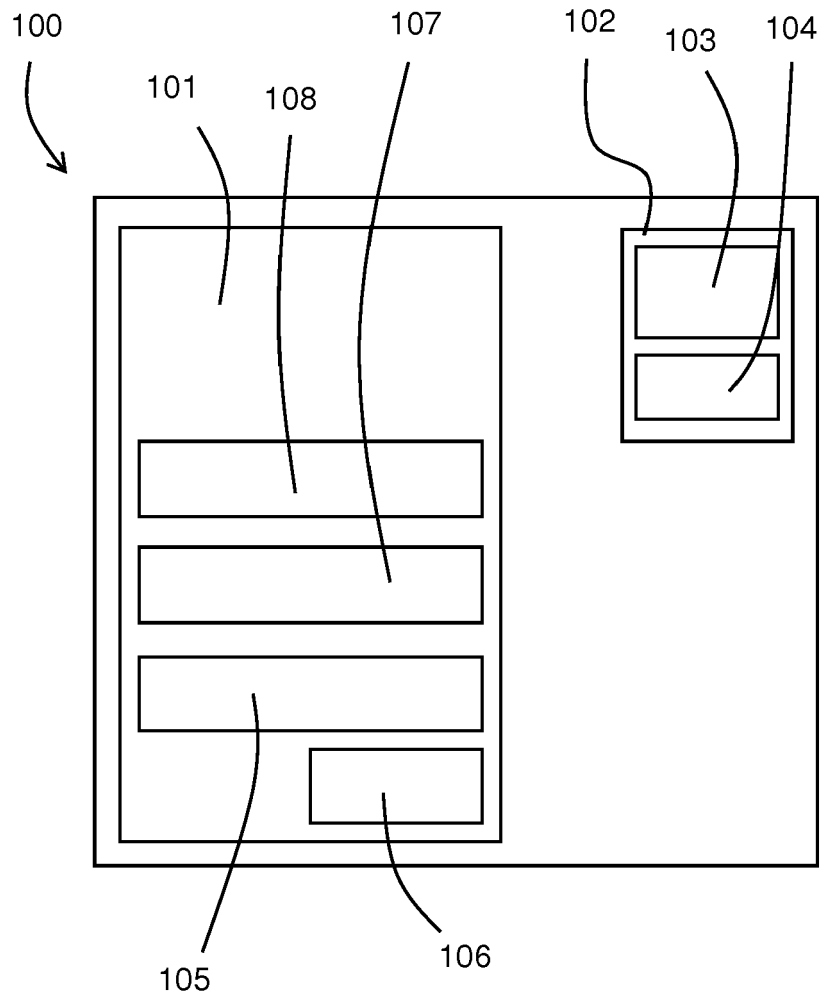
**[0129]** The words "preferred" and "preferably" are used herein refer to embodiments of the invention that may provide certain benefits under some circumstances. It is to be appreciated, however, that other embodiments may also be preferred under the same or different circumstances. The recitation of one or more preferred embodiments therefore does not mean or imply that other embodiments are not useful, and is not intended to exclude other embodiments from the scope of the disclosure, or from the scope of the claims.

## Claims

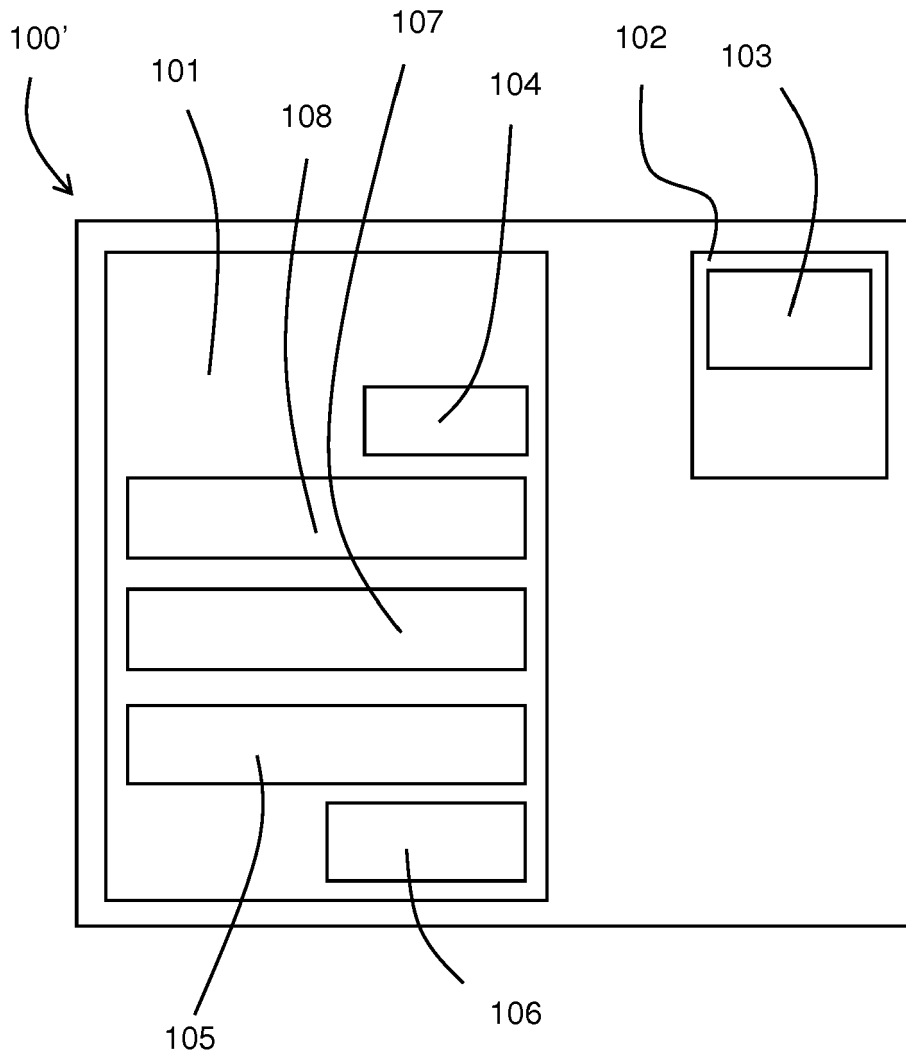
1. A heater for a heat not burn device; the heater including a longitudinal heating element including a resistive heating track formed thereon; the heater further including a mount surrounding a portion of the heating element and the heating track, wherein the heating element is formed from a heater material of a first thermal conductivity and the mount is formed from a mount material of a second thermal conductivity; the second thermal conductivity being lower than the first thermal conductivity.
2. A heater according to claim 1, wherein the first thermal conductivity is at least 3 times greater than the second thermal conductivity, preferably the first thermal conductivity is 6 times greater than the second thermal conductivity, more preferably the first ther-

mal conductivity is 10 times greater or more than the second thermal conductivity.

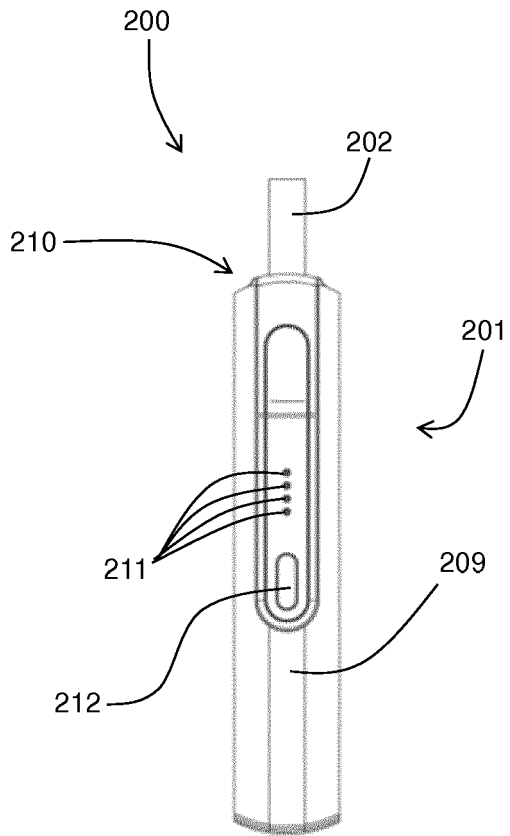
3. A heater according to at least one of the preceding claims, wherein the longitudinal heating element is configured to penetrate the tobacco portion of a consumable engaged with the device. 5
4. A heater according to at least one of the preceding claims, wherein the heater material is alumina. 10
5. A heater according to at least one of the preceding claims, wherein the mount material is zirconia.
6. A heater according to at least one of the preceding claims, wherein the resistivity of the heating track is substantially uniform along a portion of the longitudinal heating element extending between the mount and a heating region of the longitudinal heating element. 15  
20
7. A heater according to at least one of the preceding claims, wherein the mount extends longitudinally along the heating element by a distance of between 1 and 4mm. 25
8. A heater according to at least one of the preceding claims, wherein the longitudinal heating element is located within a passage through the mount. 30
9. A heater according to at least one of the preceding claims, wherein the heater includes connection means connected to the heater track at a contact location. 35
10. A heater as according to at least one of the preceding claims, wherein the contact location is on an opposite side of the mount to the heating portion of the heater.
11. A heater as according to at least one of the preceding claims, wherein the mount is connected to the device. 40
12. A heater as according to at least one of the preceding claims, wherein the mount is bonded to the device. 45
13. A substitute smoking system comprising a heat not burn device including a heater according to at least one of the preceding claim. 50
14. A method of using the system according to claim 13, the method comprising:
  - inserting the article into the device; and
  - heating the article using the heater of the device. 55



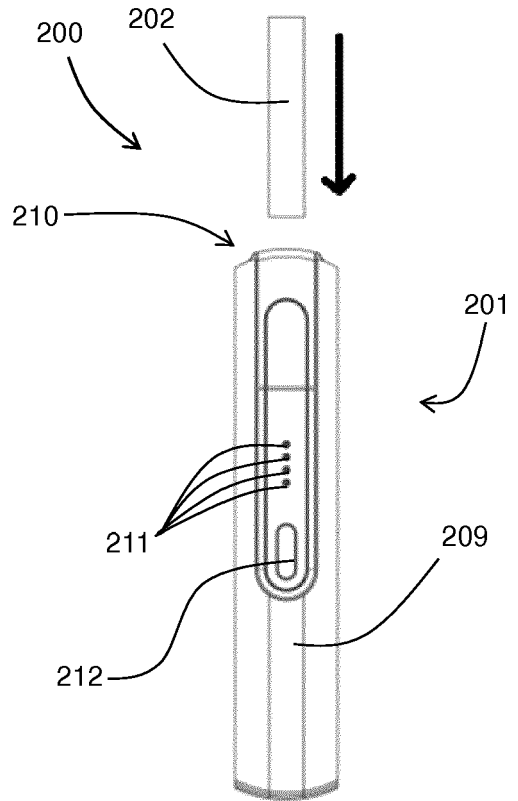
**FIG1A**



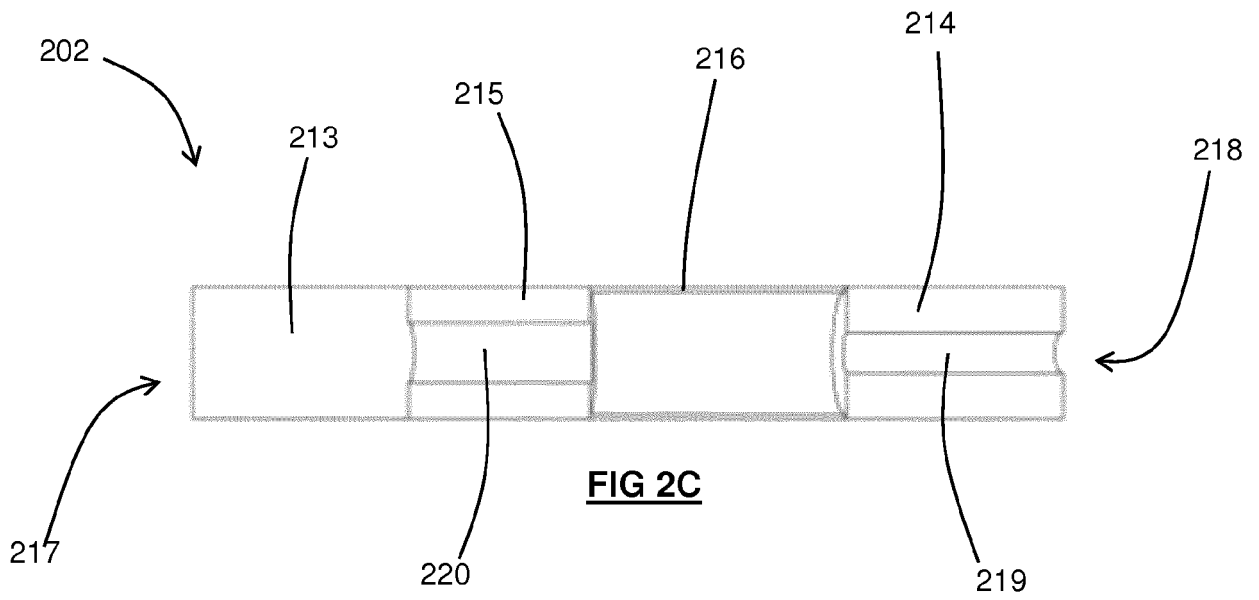
**FIG1B**



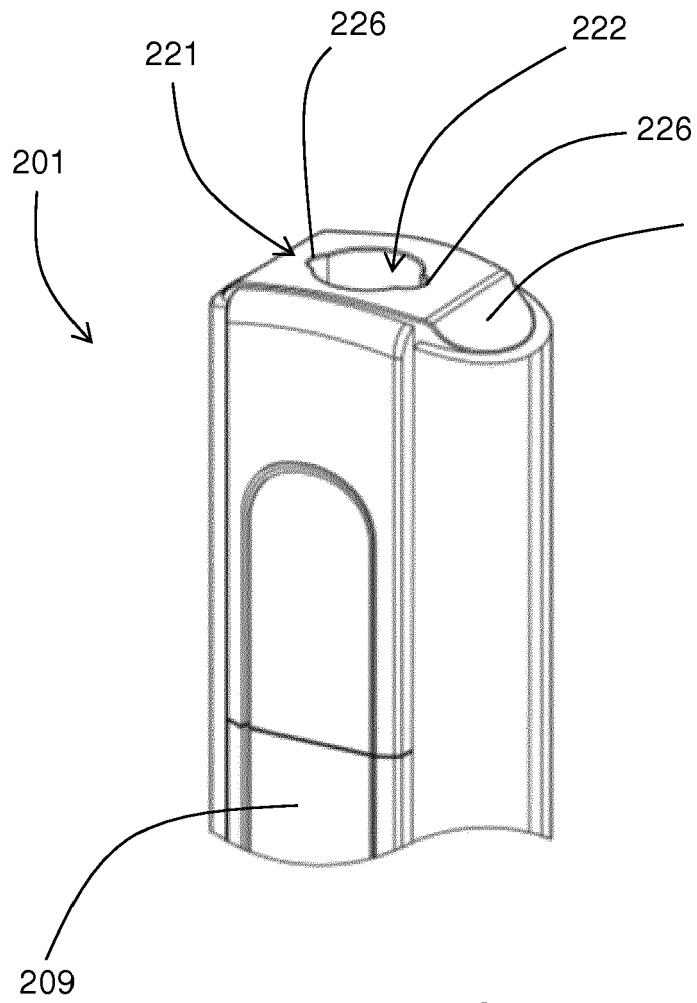
**FIG 2A**



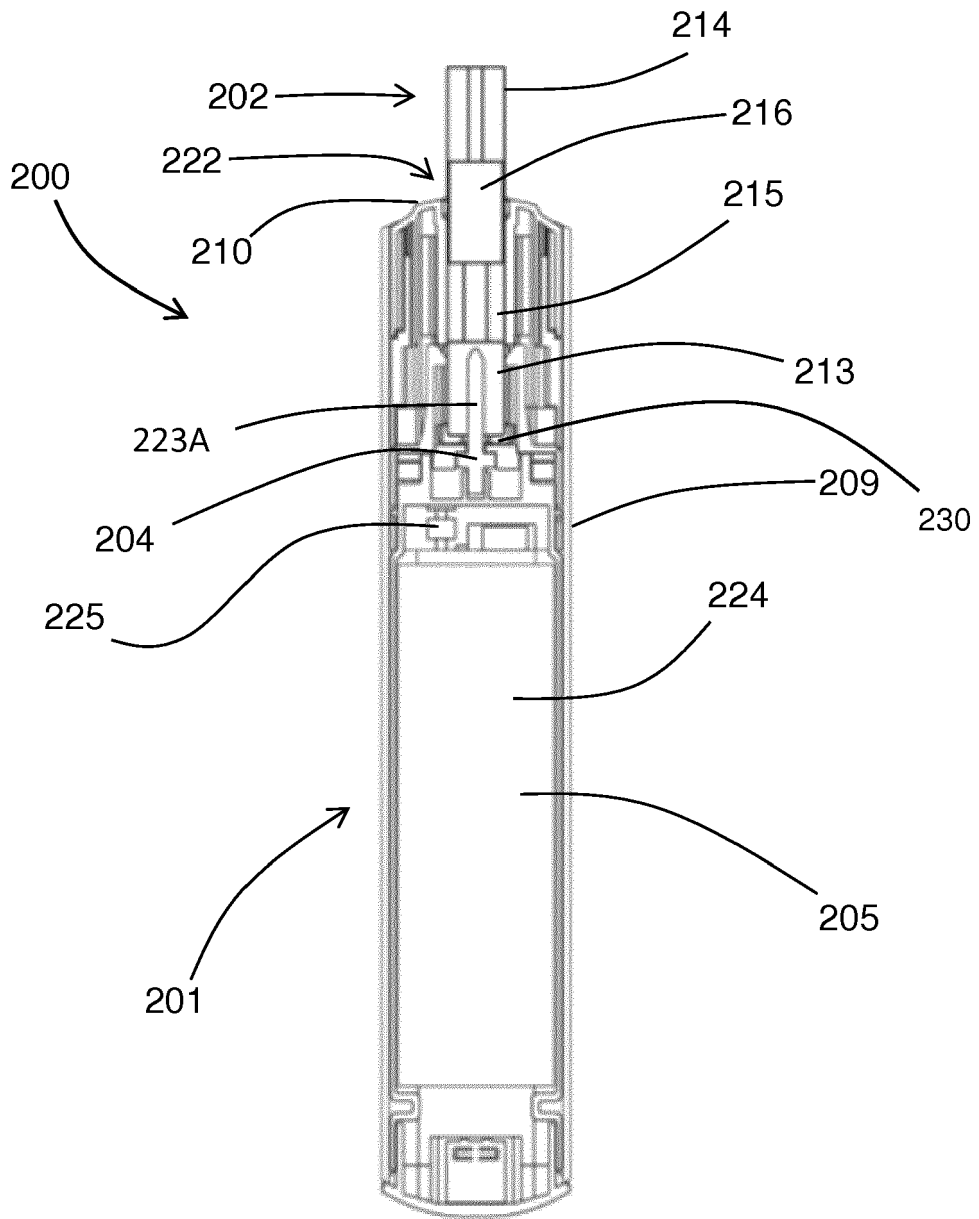
**FIG 2B**



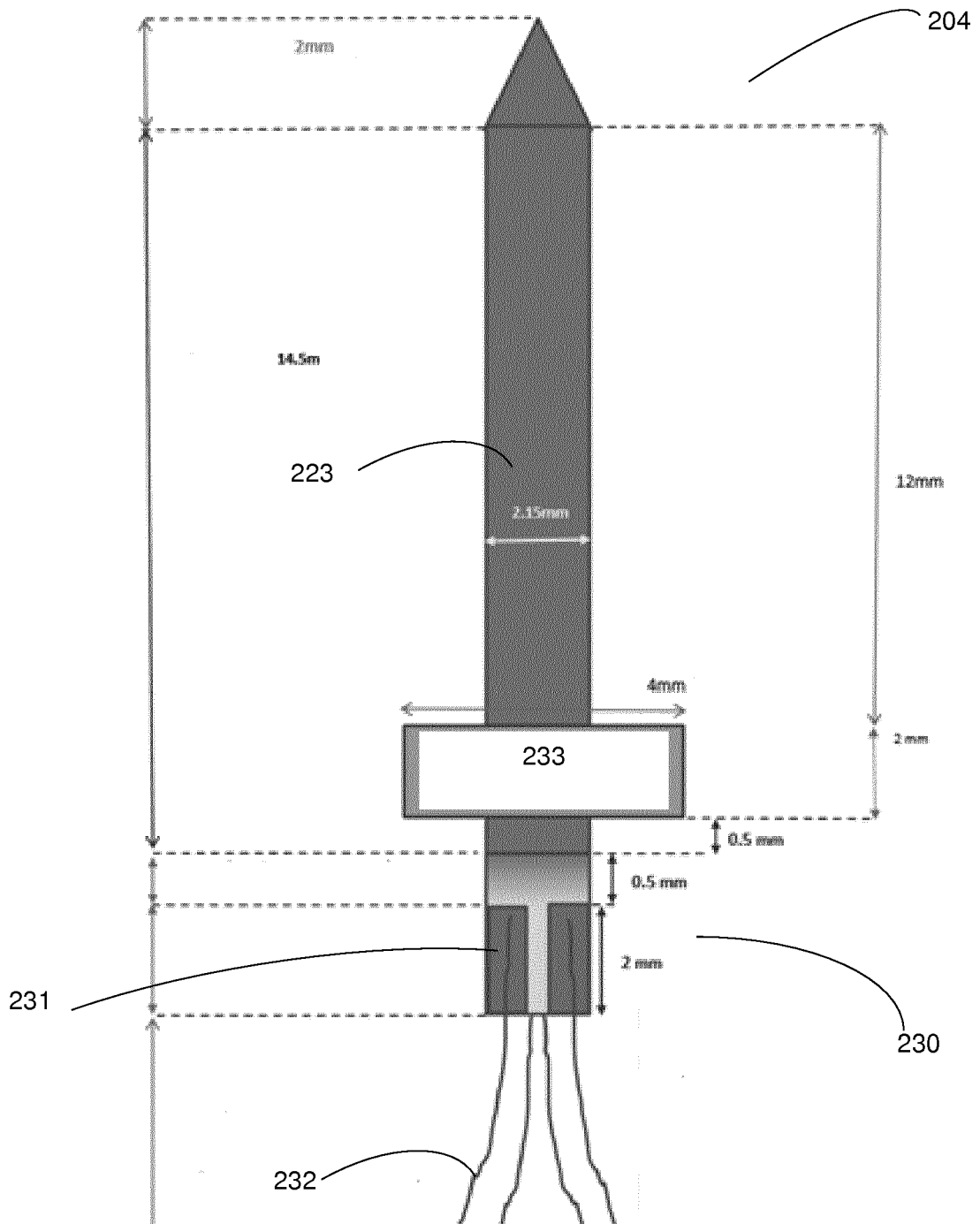




**FIG 2D**



**FIG 2E**



**FIG 3**



EUROPEAN SEARCH REPORT

Application Number  
EP 19 02 0180

5

10

15

20

25

30

35

40

45

50

55

DOCUMENTS CONSIDERED TO BE RELEVANT			
Category	Citation of document with indication, where appropriate, of relevant passages	Relevant to claim	CLASSIFICATION OF THE APPLICATION (IPC)
X	WO 2014/102092 A1 (PHILIP MORRIS PROD [CH]) 3 July 2014 (2014-07-03) * page 3, line 11 - page 5, line 29; claims; figures * * page 10, line 9 - line 11 * * page 13, line 6 - page 14, line 34 * -----	1-14	INV. A24F47/00
X	EP 2 921 065 A1 (PHILIP MORRIS PRODUCTS SA [CH]) 23 September 2015 (2015-09-23) * paragraph [0014] - paragraph [0023]; claims; figures * * paragraph [0076] - paragraph [0086] * -----	1-14	
X	WO 2016/124552 A1 (PHILIP MORRIS PRODUCTS SA [CH]) 11 August 2016 (2016-08-11) * page 2, line 6 - page 3, line 19; claims; figures * -----	1-14	
X	WO 2019/020826 A1 (PHILIP MORRIS PRODUCTS SA [CH]) 31 January 2019 (2019-01-31) * page 2, line 7 - page 5, line 16; claims; figures * -----	1-14	TECHNICAL FIELDS SEARCHED (IPC)
X	CN 109 288 133 A (HUNAN SIJIA XINJIN ELECTRONIC TECH CO LTD) 1 February 2019 (2019-02-01) * paragraph [0048] - paragraph [0058]; figures * -----	1,3,8-14	A24F A61M
X	WO 2018/217054 A1 (KT & G CORP [KR]) 29 November 2018 (2018-11-29) * paragraph [0085] * -----	1-14	
X	CN 208 242 853 U (SHENZHEN SHUNBAO TECH CO LTD) 18 December 2018 (2018-12-18) * paragraph [0034] - paragraph [0059]; figures * -----	1-3,6, 8-14	
The present search report has been drawn up for all claims			
Place of search <b>Munich</b>		Date of completion of the search <b>2 October 2019</b>	Examiner <b>Marzano Monterosso</b>
CATEGORY OF CITED DOCUMENTS X : particularly relevant if taken alone Y : particularly relevant if combined with another document of the same category A : technological background O : non-written disclosure P : intermediate document		T : theory or principle underlying the invention E : earlier patent document, but published on, or after the filing date D : document cited in the application L : document cited for other reasons ..... & : member of the same patent family, corresponding document	

EPO FORM 1503 03.82 (P04/C01)

ANNEX TO THE EUROPEAN SEARCH REPORT  
ON EUROPEAN PATENT APPLICATION NO.

EP 19 02 0180

5 This annex lists the patent family members relating to the patent documents cited in the above-mentioned European search report.  
The members are as contained in the European Patent Office EDP file on  
The European Patent Office is in no way liable for these particulars which are merely given for the purpose of information.

02-10-2019

Patent document cited in search report	Publication date	Patent family member(s)	Publication date
WO 2014102092 A1	03-07-2014	AR 094332 A1	29-07-2015
		AU 2013369493 A1	19-03-2015
		BR 112015015098 A2	11-07-2017
		CA 2886395 A1	03-07-2014
		CN 104470387 A	25-03-2015
		DK 2882308 T3	12-12-2016
		DK 3108760 T3	05-03-2018
		EP 2882308 A1	17-06-2015
		EP 3108760 A1	28-12-2016
		EP 3180998 A1	21-06-2017
		ES 2604907 T3	09-03-2017
		ES 2661166 T3	27-03-2018
		HK 1204879 A1	11-12-2015
		HU E029759 T2	28-04-2017
		HU E036091 T2	28-06-2018
		IL 237922 A	31-12-2018
		JP 5854394 B2	09-02-2016
		JP 2015524261 A	24-08-2015
		KR 20150097819 A	26-08-2015
		KR 20150099704 A	01-09-2015
		KR 20160114743 A	05-10-2016
		LT 2882308 T	10-11-2016
		LT 3108760 T	12-03-2018
		MX 356757 B	12-06-2018
		NO 3108760 T3	07-07-2018
		NZ 706399 A	27-04-2018
		PH 12015500432 A1	20-04-2015
		PL 2882308 T3	31-03-2017
		PL 3108760 T3	29-06-2018
		PT 2882308 T	08-11-2016
		PT 3108760 T	14-05-2018
		RU 2016143547 A	18-12-2018
		SG 11201501704R A	29-04-2015
		SI 3108760 T1	30-03-2018
		TW 201433269 A	01-09-2014
		UA 114651 C2	10-07-2017
		US 2015163859 A1	11-06-2015
		US 2017164659 A1	15-06-2017
		WO 2014102092 A1	03-07-2014
		ZA 201501364 B	23-12-2015
-----			
EP 2921065 A1	23-09-2015	AU 2016239643 A1	17-08-2017
		AU 2016239746 A1	06-07-2017
		BR 112017018626 A2	17-04-2018
		BR 112017018675 A2	17-04-2018
		CA 2978506 A1	06-10-2016

EPO FORM P0459

For more details about this annex : see Official Journal of the European Patent Office, No. 12/82

ANNEX TO THE EUROPEAN SEARCH REPORT  
ON EUROPEAN PATENT APPLICATION NO.

EP 19 02 0180

5 This annex lists the patent family members relating to the patent documents cited in the above-mentioned European search report.  
The members are as contained in the European Patent Office EDP file on  
The European Patent Office is in no way liable for these particulars which are merely given for the purpose of information.

02-10-2019

Patent document cited in search report	Publication date	Patent family member(s)	Publication date	
		CA 2981196 A1	06-10-2016	
		CN 107404948 A	28-11-2017	
		CN 107427079 A	01-12-2017	
		EP 2921065 A1	23-09-2015	
		EP 2921066 A1	23-09-2015	
		EP 3277108 A1	07-02-2018	
		EP 3277109 A1	07-02-2018	
		JP 2018511314 A	26-04-2018	
		JP 2018511316 A	26-04-2018	
		KR 20170133330 A	05-12-2017	
		KR 20170133333 A	05-12-2017	
		PH 12017500987 A1	18-12-2017	
		RU 2017134602 A	05-04-2019	
		RU 2017134811 A	05-04-2019	
		SG 11201705399P A	30-10-2017	
		SG 11201708054T A	30-10-2017	
		US 2018007971 A1	11-01-2018	
		US 2018235278 A1	23-08-2018	
		WO 2016156103 A1	06-10-2016	
		WO 2016156121 A1	06-10-2016	
		ZA 201704916 B	31-07-2019	
-----				
WO 2016124552	A1	11-08-2016	CA 2974234 A1	11-08-2016
			CN 107205491 A	26-09-2017
			EP 3253236 A1	13-12-2017
			ES 2724626 T3	12-09-2019
			JP 2018504130 A	15-02-2018
			KR 20170110590 A	11-10-2017
			RU 2017131056 A	05-03-2019
			TR 201905221 T4	21-05-2019
			US 2018049471 A1	22-02-2018
			WO 2016124552 A1	11-08-2016
-----				
WO 2019020826	A1	31-01-2019	TW 201909763 A	16-03-2019
			WO 2019020826 A1	31-01-2019
-----				
CN 109288133	A	01-02-2019	NONE	
-----				
WO 2018217054	A1	29-11-2018	NONE	
-----				
CN 208242853	U	18-12-2018	NONE	
-----				

EPO FORM P0459

For more details about this annex : see Official Journal of the European Patent Office, No. 12/82

55