



(12) **EUROPEAN PATENT APPLICATION**

(43) Date of publication:
04.11.2020 Bulletin 2020/45

(51) Int Cl.:
A45F 3/04 (2006.01) **A45C 13/26** (2006.01)
A45C 13/30 (2006.01)

(21) Application number: **20179575.4**

(22) Date of filing: **25.10.2018**

(84) Designated Contracting States:
AL AT BE BG CH CY CZ DE DK EE ES FI FR GB GR HR HU IE IS IT LI LT LU LV MC MK MT NL NO PL PT RO RS SE SI SK SM TR

(72) Inventors:
• **de Groot, Joris Jesaja Rowan**
5613 BE Eindhoven (NL)
• **Jacobs, Franciscus Johanna**
6035 CZ Ospel (NL)

(30) Priority: **25.10.2017 NL 2019800**

(74) Representative: **Arnold & Siedsma**
Bezuidenhoutseweg 57
2594 AC The Hague (NL)

(62) Document number(s) of the earlier application(s) in accordance with Art. 76 EPC:
18202666.6 / 3 476 247

(71) Applicant: **FJ Create B.V.**
6035 CZ Ospel (NL)

Remarks:

This application was filed on 11.06.2020 as a divisional application to the application mentioned under INID code 62.

(54) **BACKPACK**

(57) The invention relates to a bag comprising:
- a bag-like holder comprising a rear wall (3) and a carrying strip (22) provided over at least a part of the width of the rear wall and attached to the rear wall with stitching, wherein the carrying strip is attached only partially to the rear wall for the purpose of forming at least a passage (66) between the carrying strip and the rear wall, wherein the passage (66) is formed by absence of the stitching and wherein at the position of the passage (66) the carrying strip is provided with a first opening;
- at least one closing belt (40) to be fastened to the carrying strip for closing of a closing part (20) of the bag-like holder, wherein the closing belt (40) is provided with a second opening;
- a connecting element (55) for connecting the closing belt (40) to the carrying strip (22) when the closing belt (40) is arranged in the passage (66) between the carrying strip (22) and the rear wall (3) and the connecting element (55) is arranged through the first opening in the carrying strip (22) and the second opening in the closing belt (40).

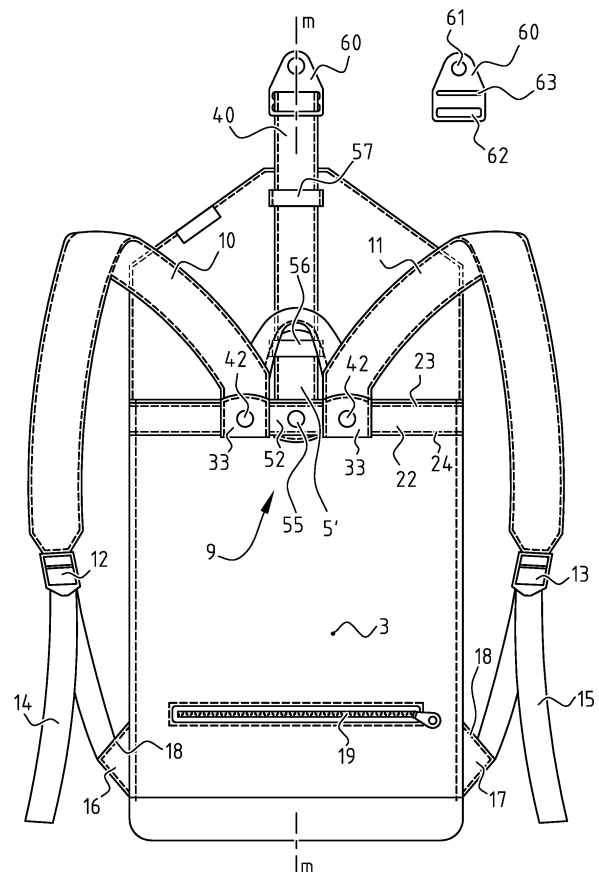

FIG. 2

Description

[0001] The invention relates to a bag, particularly a backpack.

[0002] A backpack or rucksack is a bag which is carried on the back. Some backpacks are provided with an internal or external frame, although there are also numerous backpacks in which such a frame is not present. A backpack can be characterized in that it comprises a holder in which luggage can be arranged, wherein the holder is hung on the back of the user by means of one or more carrying belts, such as shoulder straps, which are guided round the shoulder of the user. These carrying belts support the greater part of the weight of the backpack and the contents thereof.

[0003] Numerous different types of backpack are known. The thing all these backpacks have in common is that the fastening of the carrying belts to the holder can become damaged after (possibly prolonged) use. The weight having to be supported by the carrying belts is high and the forces resulting therefrom, which are continuously exerted on the fastening of the carrying belts to the holder of the backpack, can for instance result in tearing of the carrying belts or of the material of the holder. This is the case particularly, though not exclusively, when the carrying belts are fastened to the holder with a hard and stiff connecting element such as a metal fastening screw or the like. Said forces here concentrate on a small area (i.e. a relatively small contact surface between the connecting element and the material of the carrying belt and the holder). The risk of damage to the material of the carrying belt and holder is hereby considerable.

[0004] An example of such a backpack is described in the Japanese document JP2002233408 A. The document describes a backpack to which are fastened two carrying belts with which a user can carry the backpack. The carrying belts (8) are fastened to the backpack by securing them with hooks (18) to a horizontal reinforcing band (17), this in turn being fastened to the backpack.

[0005] A drawback of known backpacks can be that the carrying belts and any belts that may be used to close the backpack tend to tear loose at the position of said hooks. This tearing loose has been found to be caused by the great forces being exerted on a relatively small area (i.e. the area defined by the dimensions in cross-section of the hook with which the carrying belts are fastened). For the same reason, the carrying belts of the known backpacks further have to be manufactured from a material which has good resistance to tearing, which limits the material choice and/or increases costs. A further drawback is that high structural demands are made of the connecting means (for instance the above mentioned hooks).

[0006] It is an object of the invention to provide an improved backpack in which the above stated drawback is obviated or reduced.

[0007] It is also an object of the invention to provide a backpack with a relatively small risk of tearing, also in

the case of prolonged and intensive use.

[0008] At least one of the above stated objectives and/or other objectives is achieved according to a first aspect of the invention in a bag, particularly a backpack, comprising:

- a bag-like holder comprising a rear wall and a carrying strip provided over at least a part of the width of the rear wall and attached to the rear wall with stitching, wherein the carrying strip is attached only partially to the rear wall for the purpose of forming at least a passage between the carrying strip and the rear wall, wherein the passage is formed by absence of the stitching and wherein at the position of the passage the carrying strip is provided with a first opening;
- at least one closing belt to be fastened to the carrying strip for closing of a closing part of the bag-like holder, wherein the closing belt is provided with a second opening;
- a connecting element for connecting the closing belt to the carrying strip when the closing belt is arranged in the passage between the carrying strip and the rear wall and the connecting element is arranged through the first opening in the carrying strip and through the second opening in the closing belt.

[0009] In a preferred embodiment the closing belt has a first free outer end at which a buckle is arranged and a second free outer end in which the second opening is arranged.

[0010] In a preferred embodiment the first free end of the closing belt comprises a magnetic closure.

[0011] In a preferred embodiment the buckle is provided with an element, for instance a passage in which is mounted a magnetic part, forming a magnetic closing together with another magnetic part which is mounted in the front side of the holder.

[0012] In a preferred embodiment a third opening is arranged at the position of the passage in the rear wall. The connecting element may extend through the first opening in the carrying strip, through the second opening in the closing belt and through the third opening in the rear wall, when the closing belt is arranged in the passage between the carrying strip and the rear wall.

[0013] In a preferred embodiment the holder is provided on the upper side with a closable opening and further comprises a front wall, a rear wall facing toward the back of the user, a left-hand side wall, a right-hand side wall, a bottom and a closing part, such as a closing flap, with which the holder can be closed in known manner.

[0014] Arranging the carrying elements on such a carrying strip using a loop in the outer end enables the occurring forces to be transmitted to the carrying elements evenly distributed over the carrying strip and over the width of each of the carrying elements. The risk of damage as a result of excessive loading of the holder, carrying strip or carrying element can thereby be reduced.

[0015] The bag can be a frameless bag (i.e. a bag without internal or external strengthening frame) or a bag with such a frame. In this latter case there is sometimes the option of arranging a carrying strap on the frame itself, whereby the risk of tearing can per se be reduced. Such a bag however has a less attractive appearance (for instance in the case of an external frame) or requires one or more openings in the woven material of the holder in order to provide the carrying straps with the possibility of being fastened to the internal frame via these openings.

[0016] The above stated fastening can comprise a connecting element to be secured in the openings, such as an assembly of a bolt and a nut. Other types of connecting element can however also be applied. It is for instance also possible to fixedly clamp the outer end of the carrying element to the other part of the carrying element using a clamp.

[0017] In determined embodiments of the invention the carrying strip extends in a direction substantially transversely of the axial direction (for instance a direction corresponding to the centre line between the bottom and the closing element of the bag).

[0018] The one or more passages can be embodied to extend in a substantially axial direction so that one or more closing belts can easily be slid through the passages from top to bottom.

[0019] In order to form the passage the carrying strip can be attached to the rear wall with stitching which is interrupted at the position of the passages.

[0020] Further details, features and properties of the invention will be elucidated on the basis of the following description of several embodiments thereof. Reference is made in the description to the figures, in which:

Figure 1 is a view of a person carrying an embodiment of the backpack according to the invention;
 Figure 2 is a view of the rear side of the backpack of Figure 1;
 Figure 3 is a view of the front side of the backpack of Figures 1 and 2;
 Figure 4 is a right-hand side view;
 Figure 5 is a left-hand side view of the backpack;
 Figure 6 is a detail view of a carrying element;
 Figure 7 is a detail view of a closing belt;
 Figure 8 is a detail view of a carrying strip;
 Figures 9A-9C are respective perspective views showing the fastening of a carrying belt to the carrying strip.

[0021] Referring to the figures, a user (P) carrying a backpack on his back (R) is shown. The backpack comprises a bag-like holder 1 which is provided on the upper side with a closable opening. The bag-like holder 1 is constructed from inter alia a front wall 2, a rear wall 3 facing toward the back of the user, a left-hand side wall 5, a right-hand side wall 6, a bottom 4 and a closing part 20, such as a closing flap 20 with which the holder can be closed in known manner. Figure 2 shows that a zip

fastening 19 is arranged in the rear wall 3 of the holder. This zip fastening can be opened in order to gain access to a compartment of the holder provided on rear wall 3.

[0022] In order to enable holder 1 to be carried on the back a number of carrying elements, particularly a number of carrying straps, is provided. In the shown embodiment holder 1 is supported by a first carrying element 10 and a second carrying element 11. Carrying element 10 is fastened with its one outer end to the rear wall 3 of holder 1, this at a position just above the centre of the holder, while the opposite outer end of carrying element 10 is fastened by means of stitching 18 to a support 16 provided on the lower side of rear wall 3. In the shown embodiment carrying element 10 comprises a carrying belt or carrying strap. The carrying belt or carrying strap is constructed from two parts which are mutually connected with a buckle 12 so that the length of the carrying belt or carrying strap can be adjusted as desired. The carrying element is thus adjustable in the shown embodiment. The second carrying element 11 has the same construction and is fastened on the lower side to a similar support 17.

[0023] The connection of each of the carrying elements 10, 11 to the rear wall 3 of holder 1 is susceptible to wear and damage. It is after all the case that relatively large forces are exerted on this connection, since substantially the whole weight of the backpack and contents rests thereon. In known backpacks (wherein carrying belts are fastened directly to the rear wall or a reinforcement provided therein via fastening means such as screws and the like) it is common in practice that, after (possibly prolonged) use, damage to the connection occurs, for instance tearing of the carrying elements and/or the rear wall or damage at the position of said fastening means. This damage can eventually result in one or more of the carrying elements becoming wholly or partially detached from the holder, whereby the backpack becomes unusable. In the shown embodiment of the fastening of the invention this is however no longer the case.

[0024] An embodiment of a carrying element 10, 11 according to the invention is shown in more detail in figure 6. Carrying element 10, 11 comprises an elongate main part and an oblique part 31 extending at a slight angle relative to the main part. This oblique part comprises a bendable end part 33 and a part 32 connecting to the end part 33. In determined embodiments a fold 36 is provided between the bendable end part 33 and the part 32 connecting thereto (although in other embodiments this fold has been dispensed with). The fold facilitates the bending of end part 33. The bent end part 33 forms a loop which can be arranged round a carrying strip 22 secured to the rear wall of the backpack.

[0025] In the shown embodiment carrying strip 22 extends substantially transversely of the axial direction of the backpack and is secured to rear wall 3 with upper stitching 23 and lower stitching 24. As shown in figure 8, carrying strip 22 can also be provided with axially extending stitching 41 which provides for an extra strong con-

nection between the carrying strip and the rear wall of the holder. Stitching 23, 24 is interrupted at a number of locations so as to form a number of passages 64, 65, 66 between the inner side of carrying strip 22 and the outer side of rear wall 3. Passages 64, 65 have a width such that the outer end, more particularly the bendable part 33, of a carrying element 10, 11 can be passed there-through. The stitching is further interrupted for the purpose of forming a third passage 66 (figure 8) along which a closing belt 40 can be passed.

[0026] Figures 9A-9C show the manner of fastening of carrying elements 10, 11 to carrying strip 22 in more detail. Figure 9A shows the outer end 33 of carrying element 10 which is carried into a passage 64, 65 in the direction P_1 . Once outer end 33 has been slid far enough through passage 64, 65, for instance when the upper side of carrying strip 22 has reached the bend 30 in carrying element 10, the bendable outer end 33 can be bent (P_2) so that outer end 33 can be placed on carrying strip 22. This situation is shown in figure 9B. Outer end 33 is then fastened to another part of carrying belt 10, 11 and/or to rear wall 3 of the holder. There are different ways of fastening the outer end 33, once it has been bent, to the carrying belt and/or the holder.

[0027] The fastening can be realized in different ways. The figures show an embodiment in which arranged in the bendable end part 33 is a first opening 35, arranged in the part 32 of the carrying belt connecting thereto is a second opening 34, and arranged in carrying strip 22 itself is an opening 37. The openings are dimensioned such and positioned in such a manner that all openings lie one above the other and wholly or partially overlap. A passage through end part 33, strip 22 and connecting part 32 is hereby realized.

[0028] A connecting element 38 can be placed into this passage in order to enable fastening of the loop to the carrying strip. Connecting element 38 can take numerous forms. In the embodiment shown in figure 9B connecting element 38 comprises a bolt 42 provided with a wide head and a nut 39 which can be screwed thereon.

[0029] In determined embodiments a (fourth) opening is in any case also arranged in rear wall 3 of holder 1 at a corresponding position. In this embodiment the passage therefore also extends through the material of holder 1 itself so that connecting element 38 passes not only through the carrying element and the carrying strip, but also through the holder. Nut 39 is then screwed on on the inner side of the bag-like holder.

[0030] By fastening the carrying elements to the carrying strip with a loop the load-bearing forces on carrying elements 10, 11, carrying strip 22 and/or rear wall 3 are distributed well over the whole width of the carrying element and particularly at the portion along the lower edge of carrying strip 22. In other words, a line coupling (i.e. a coupling over the line formed by fold 36 of the bent carrying element) occurs here, rather than a point coupling between a carrying element and the carrying strip (i.e. a point coupling at the position of the connecting element).

The load-bearing forces are in any case not exerted primarily on the connecting element 38. The risk of tearing of the openings at the position of connecting element 38 is thus greatly reduced. The forces exerted on carrying strip 22 are moreover transmitted via all stitching 23, 24, 41 to the rear wall of the backpack. By providing the carrying strip over more than half the width of the rear wall of holder 1, preferably over the whole width of the rear wall or even over the whole width of the rear wall and a part of the side walls, and stitching it on over this width, the load-bearing forces on carrying strip 22 are distributed over a relatively wide area of the holder. This also reduces the risk of damage to the backpack.

[0031] Figure 2 further shows that the first carrying belt 10 is passed through a passage 64 (see figure 8) which is positioned to the left of the centre line (m) and the second carrying element 11 engages on the strip 22 in that it is passed through a right-hand passage 65 (see figure 8) positioned to the right of the centre line (m). The two carrying elements 10, 11 are positioned mirror-symmetrically relative to the axial centre line in order to bring about a balanced distribution of forces on carrying strip 22. The above stated closing belt 40 is arranged at a position between the two carrying elements 10, 11 (figure 2). This closing belt 40 is arranged on the holder in known manner by means of a connecting element 55 arranged through openings in closing belt 40, rear wall 3 and strip 22. Support tongues 56, 57 are further arranged on closing flap 20 in order to guide closing belt 40 neatly upward from carrying strip 22. The buckle 60 is arranged at the free outer end of closing belt 40. The length of closing belt 40 can be varied (in known manner) by sliding closing belt 40 through two slots 62, 63 in buckle 60. Buckle 60 is also provided with an element 61. Element 61 is a passage in which is mounted a magnetic part, this functioning together with another magnetic part which is mounted in the front side of the bag as magnetic closure of the bag. In determined embodiments use is made of a closure from Fidlock GmbH.

[0032] Carrying elements 10, 11 and strip 22 can be manufactured from different materials. In a determined embodiment carrying belts 10, 11 are manufactured largely from leather or woven material.

[0033] Further, the disclosure comprises examples according to the following clauses:

Clause 1. Bag, comprising:

- a bag-like holder comprising a rear wall and a carrying strip provided over at least a part of the width of the rear wall and attached to the rear wall with stitching, wherein the carrying strip is attached only partially to the rear wall for the purpose of forming at least a passage between the carrying strip and the rear wall, wherein a passage is formed by absence of the stitching;
- at least one carrying element to be fastened to the carrying strip for carrying of the bag-like hold-

er by the user, wherein each carrying element comprises a loop-like outer end which extends through the passage and round the carrying strip in use;

- a fastening for fastening an end part of the loop-like outer end of the carrying element to another part of the carrying element.

Clause 2. Bag as defined in clause 1, wherein the bag-like holder, the carrying strip and, preferably, the carrying element are manufactured from flexible material, for instance from at least one of woven material or leather; and/or wherein the bag is embodied without support frame.

Clause 3. Bag as defined in any one of the preceding clauses, wherein the passage extends from the lower edge to the upper edge of the carrying strip.

Clause 4. Bag as defined in any one of the preceding clauses, configured to pass the carrying element through the whole passage and around the whole carrying strip for the purpose of being fastened to the carrying strip.

Clause 5. Bag as defined in any one of the preceding clauses, wherein the width of a passage corresponds to the width of the bendable part of the carrying element.

Clause 6. Bag as defined in any one of the preceding clauses, wherein a first opening is formed in the bendable end part and a corresponding second opening is formed in the part of the carrying element connecting to the end part, and wherein, in the situation in which the carrying element has been passed through the passage and bent, the first and second opening overlap each other partially or wholly.

Clause 7. Bag as defined in any one of the preceding clauses, comprising at least a third opening which is arranged in the carrying strip such that, in the situation in which the carrying element has been passed through the passage and bent, the first, second and third openings overlap each other partially or wholly.

Clause 8. Bag as defined in any one of the preceding clauses, comprising at least a fourth opening which is arranged in the rear wall such that, in the situation in which the carrying element has been passed through the passage and bent, the first, second, third and fourth openings overlap each other partially or wholly.

Clause 9. Bag as defined in clause 8 or 9, wherein the dimensions and position of the opening in the carrying strip have been chosen relative to the dimensions and position of the first and second opening in the carrying element such that the connecting element extends substantially movably in the third opening in use.

Clause 10. Bag as defined in any one of the preceding clauses, wherein the carrying element and carrying strip are embodied to fasten the carrying element releasably to the holder and/or wherein the bag

is a backpack, wherein the rear wall of the bag-like holder faces toward the back of a user in use.

Clause 11. Bag as defined in any one of the preceding clauses, wherein the carrying element comprises a bendable end part, wherein the bendable end part is configured to be passed behind the carrying strip via a passage and to then be bent, wherein the fastening is configured to fasten the bendable outer end, which has been passed through the passage and bent, to another part of the carrying element.

Clause 12. Bag as defined in any one of the preceding clauses, wherein the loop-like outer end of the carrying element extends round the carrying strip such that the forces on the carrying element are at least partially, preferably substantially, absorbed by the lower edge of the carrying strip.

Clause 13. Bag as defined in any one of the preceding clauses, wherein the contact surface between the carrying element and the carrying strip is substantially linear, wherein the length of the linear contact amounts to at least 2 cm, preferably at least 4 cm.

Clause 14. Bag as defined in any one of the preceding clauses, wherein the fastening comprises a connecting element to be secured in the openings, wherein the connecting element preferably comprises a bolt and nut assembly.

Clause 15. Bag as defined in any one of the preceding clauses, wherein the carrying strip extends in a direction substantially transversely of the axial direction, the one or more passages extend in a substantially axial direction, and/or the passages extend at symmetrical positions relative to an axial centre line (m) and/or comprising a left-hand carrying element engaging on a first passage which is positioned to the left of the centre line (m) and a right-hand carrying element engaging on a second passage which is positioned to the right of the centre line (m).

[0034] The present invention is not limited to the embodiment described here. The scope of protection is defined by the appended claims, within the scope of which many modifications and adjustments can be envisaged.

Claims

1. Bag, comprising:

- a bag-like holder comprising a rear wall (3) and a carrying strip (22) provided over at least a part of the width of the rear wall and attached to the rear wall with stitching, wherein the carrying strip is attached only partially to the rear wall for the purpose of forming at least a passage (66) between the carrying strip and the rear wall, wherein the passage (66) is formed by absence of the stitching and wherein at the position of the passage (66) the carrying strip is provided with a

- first opening;
 - at least one closing belt (40) to be fastened to the carrying strip for closing of a closing part (20) of the bag-like holder, wherein the closing belt (40) is provided with a second opening;
 - a connecting element (55) for connecting the closing belt (40) to the carrying strip (22) when the closing belt (40) is arranged in the passage (66) between the carrying strip (22) and the rear wall (3) and the connecting element (55) is arranged through the first opening in the carrying strip (22) and through the second opening in the closing belt (40).
2. Bag according to claim 1, wherein the closing belt (40) has a first free outer end at which a buckle (60) is arranged and a second free outer end in which the second opening is arranged.
 3. Bag according to claim 2, wherein the first free end of the closing belt (40) comprises a magnetic closure.
 4. Bag according to claim 2 or 3, wherein the buckle (60) is provided with an element (61), for instance a passage in which is mounted a magnetic part, forming a magnetic closing together with another magnetic part which is mounted in the front side of the holder.
 5. Bag according to any of the preceding claims, wherein at the position of the passage (66) a third opening is arranged in the rear wall (3) and wherein the connecting element (55) extends through the first opening in the carrying strip (22), through the second opening in the closing belt (40) and through the third opening in the rear wall (3) when the closing belt (4) is arranged in the passage (60) between the carrying strip (22) and the rear wall (3).
 6. Bag as claimed in any of the proceedings claims, wherein the holder (1) is provided on the upper side with a closable opening and further comprises a front wall (2), a rear wall (3) facing toward the back of the user, a left-hand side wall (5), a right-hand side wall (6), a bottom (4) and a closing part (20), such as a closing flap, with which the holder can be closed in known manner.
 7. Bag as claimed in any of the preceding claims, wherein the bag-like holder and the closing belt (40) are manufactured from flexible material, for instance from at least one of woven material or leather; and/or wherein the bag is embodied without support frame.
 8. Bag as claimed in any one of the preceding claims, wherein the passage (66) extends from the lower edge to the upper edge of the carrying strip.
 9. Bag as claimed in any one of the preceding claims, wherein the width of the passage (66) corresponds to the width of the closing belt (40).
 10. Bag as claimed in any one of the preceding claims, wherein the first and second openings in the carrying strip (22) and the closing belt (40) overlap each other when the closing belt (40) is arranged in the passage (66) and is connected to the carrying strip (22).
 11. Bag as claimed in any one of the preceding claims, wherein the closing belt (40) and carrying strip are embodied to fasten the closing belt (40) releasably to the holder and/or wherein the bag is a backpack, wherein the rear wall of the bag-like holder faces toward the back of a user in use.
 12. Bag as claimed in any one of the preceding claims, wherein the carrying strip (22) extends in a direction substantially transversely of the axial direction, the one or more passages (66) extend in a substantially axial direction.

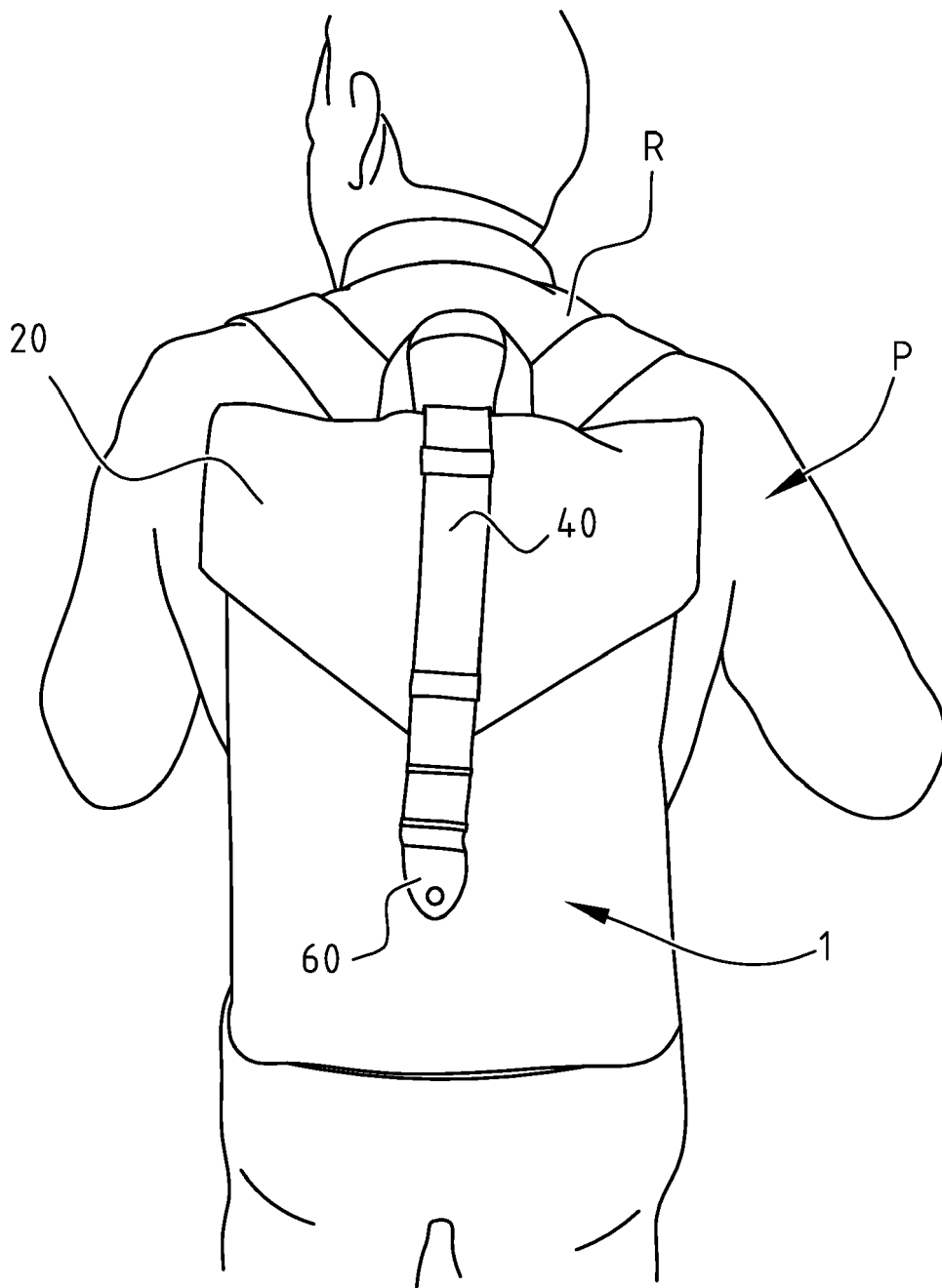

FIG. 1

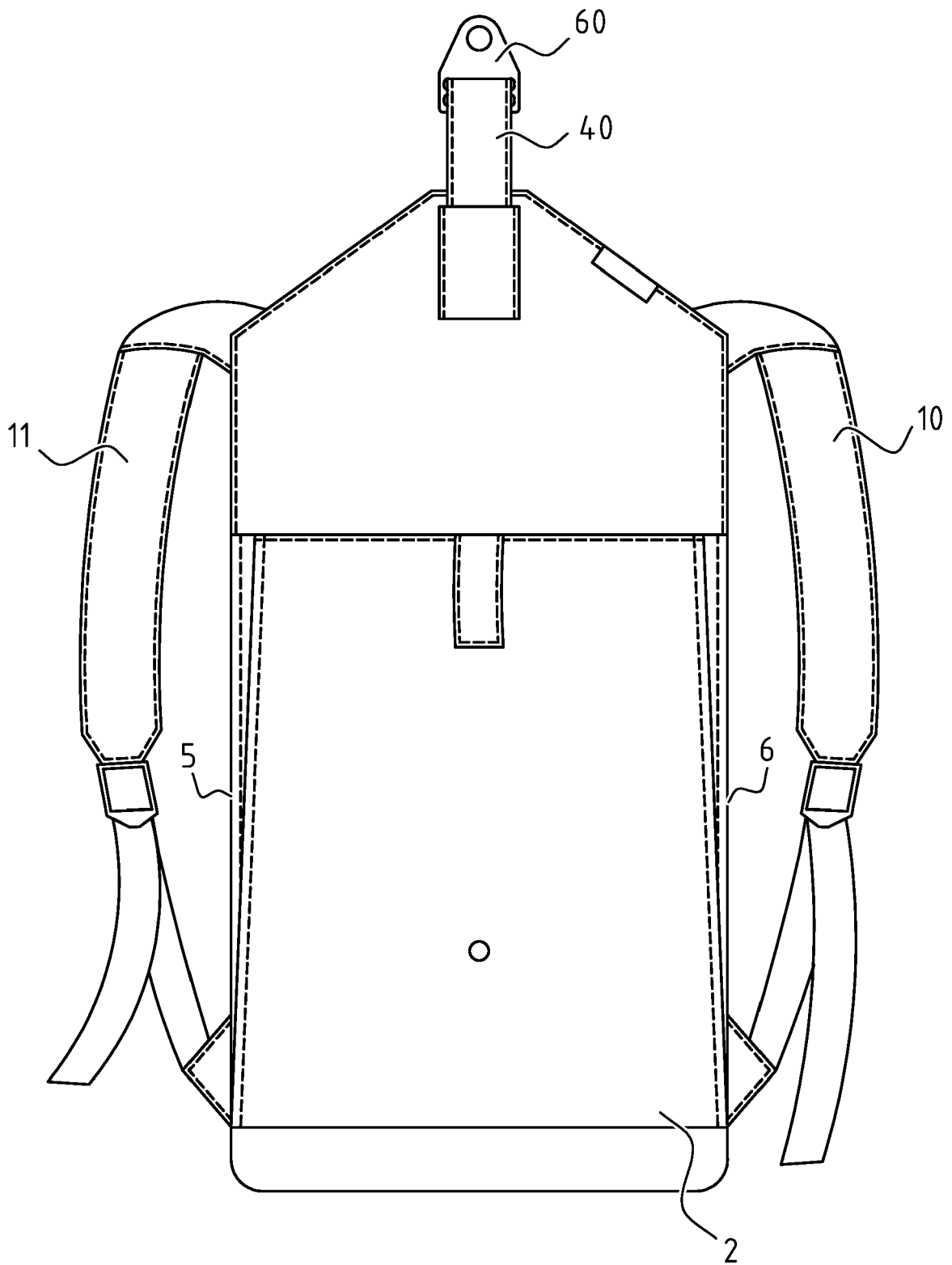

FIG. 3

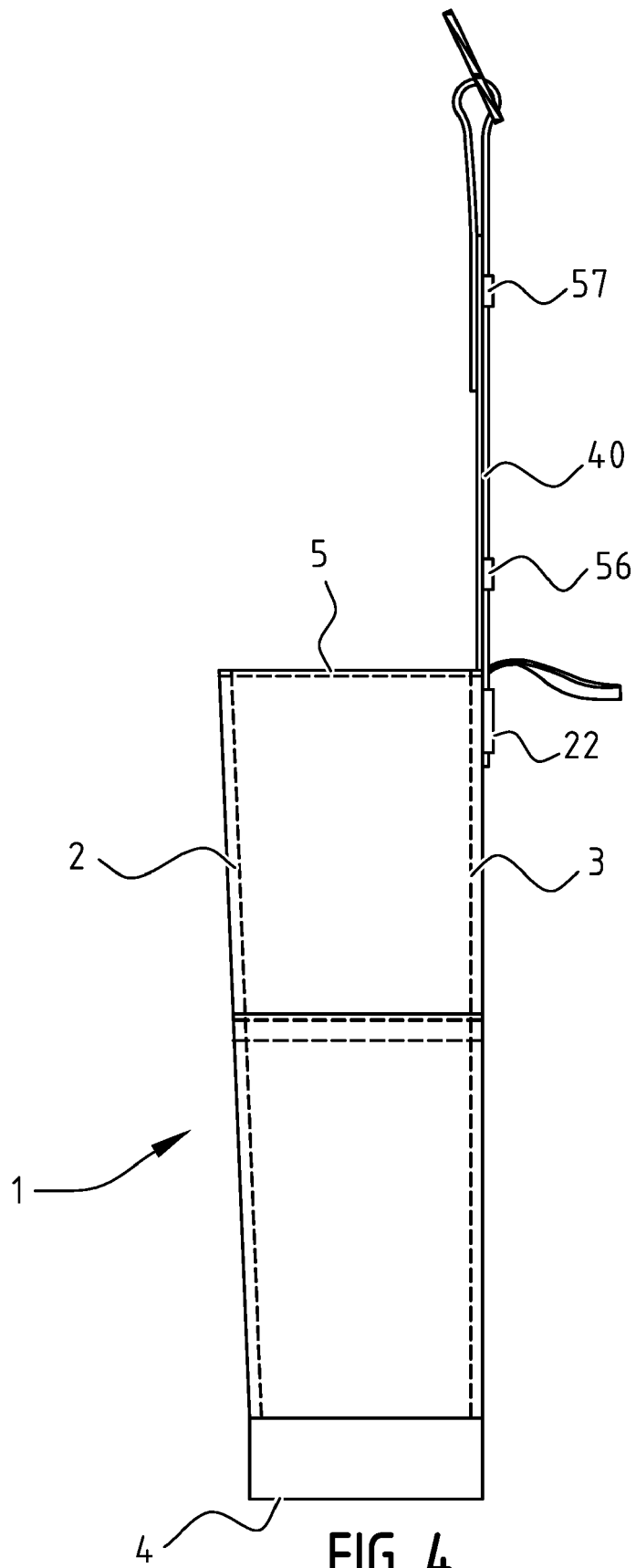

FIG. 4

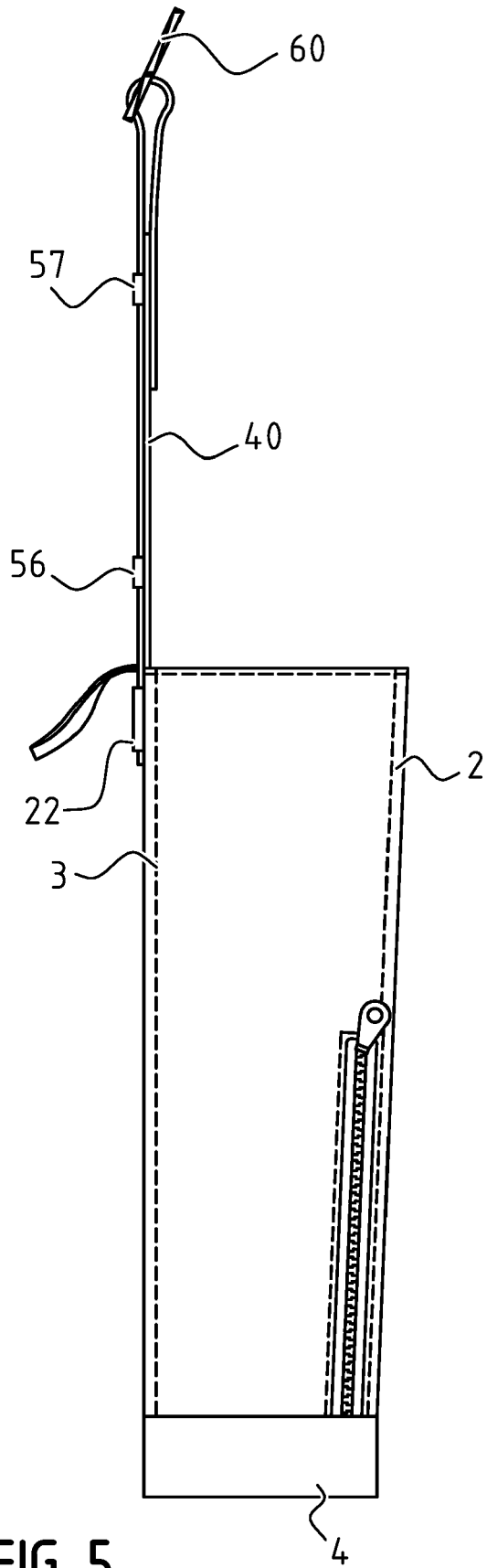

FIG. 5

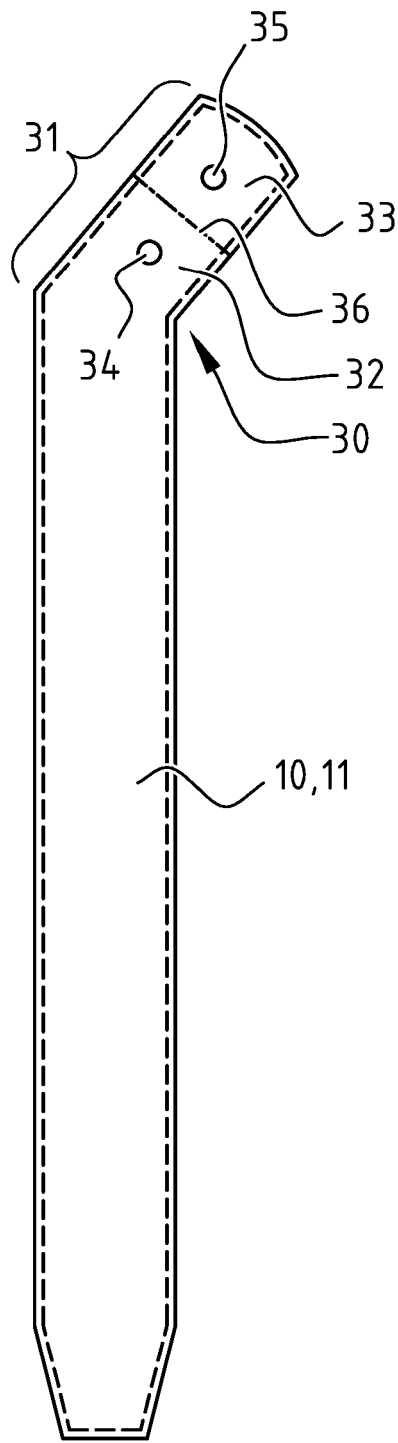

FIG. 6

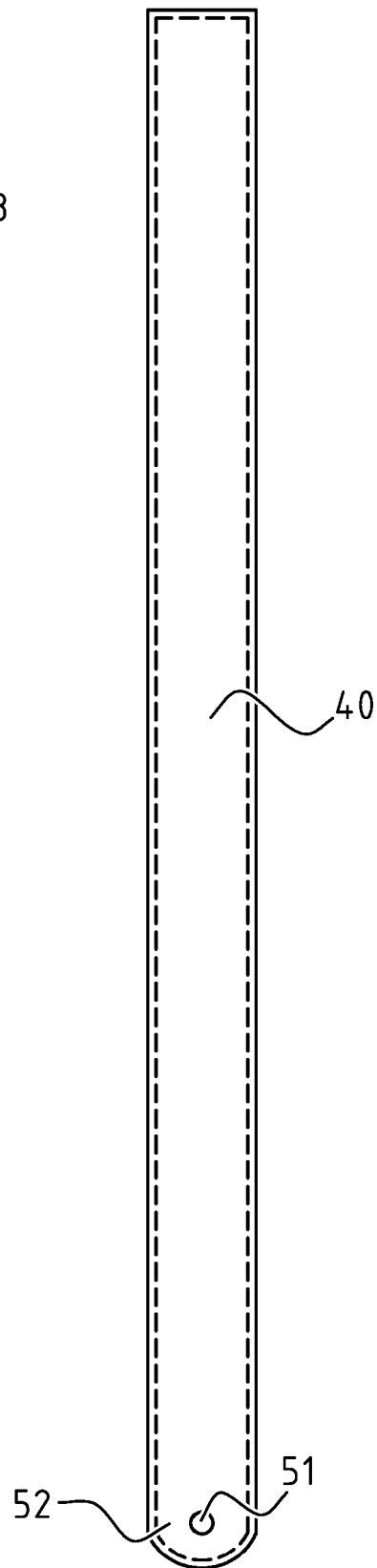

FIG. 7

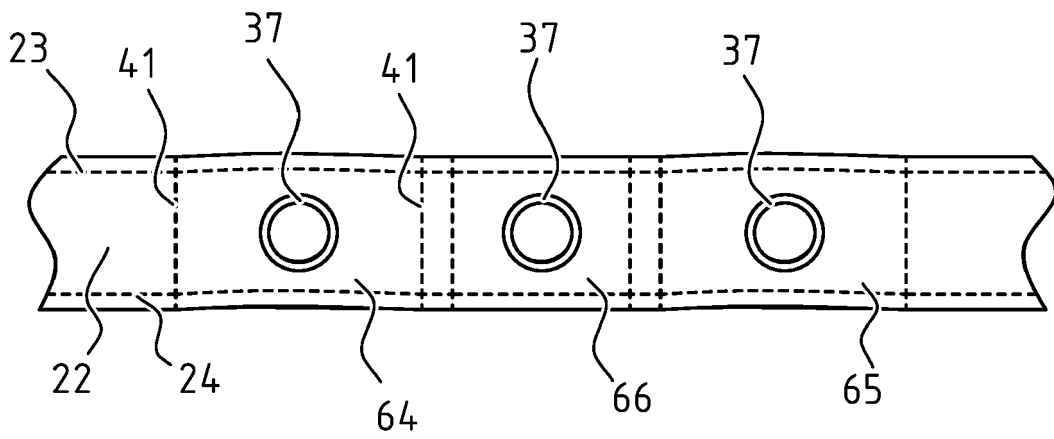

FIG. 8

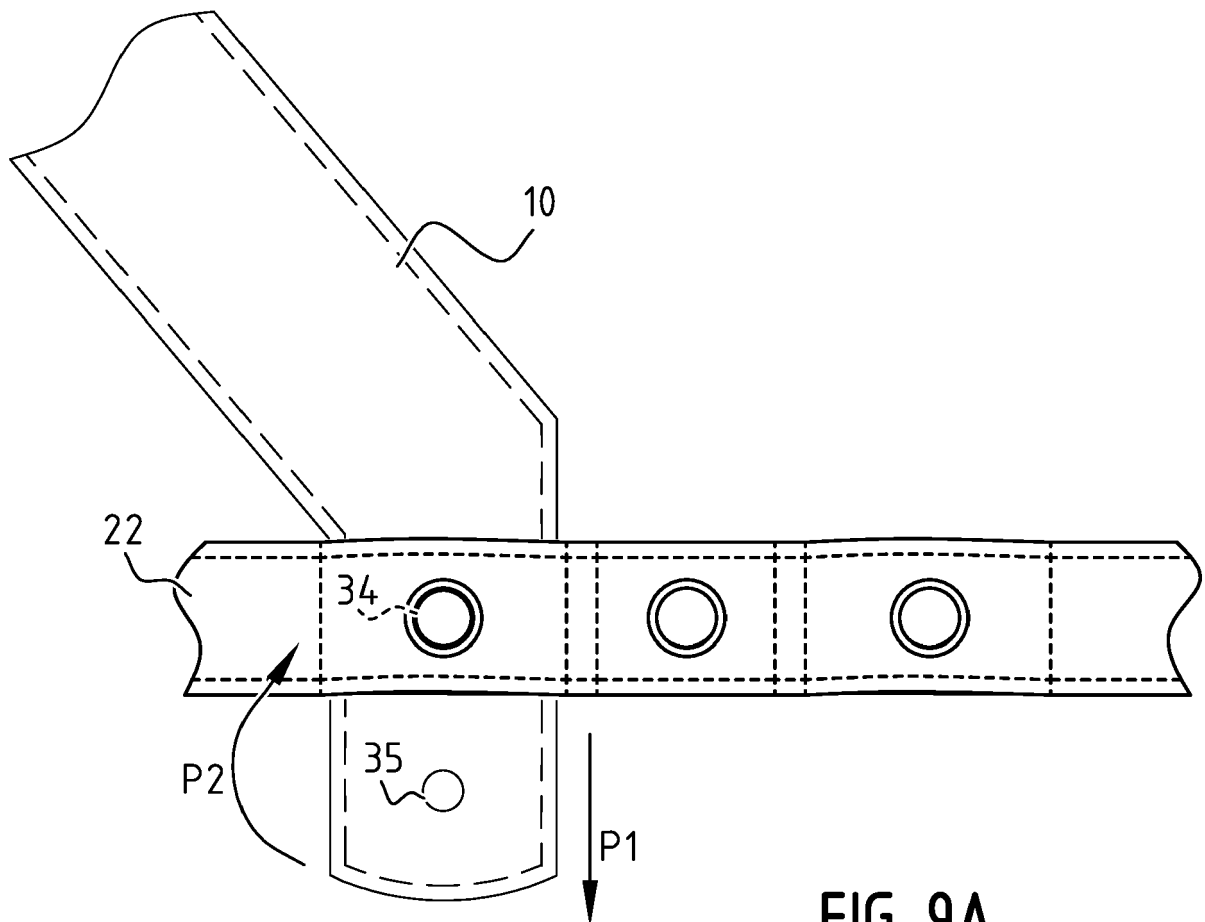

FIG. 9A

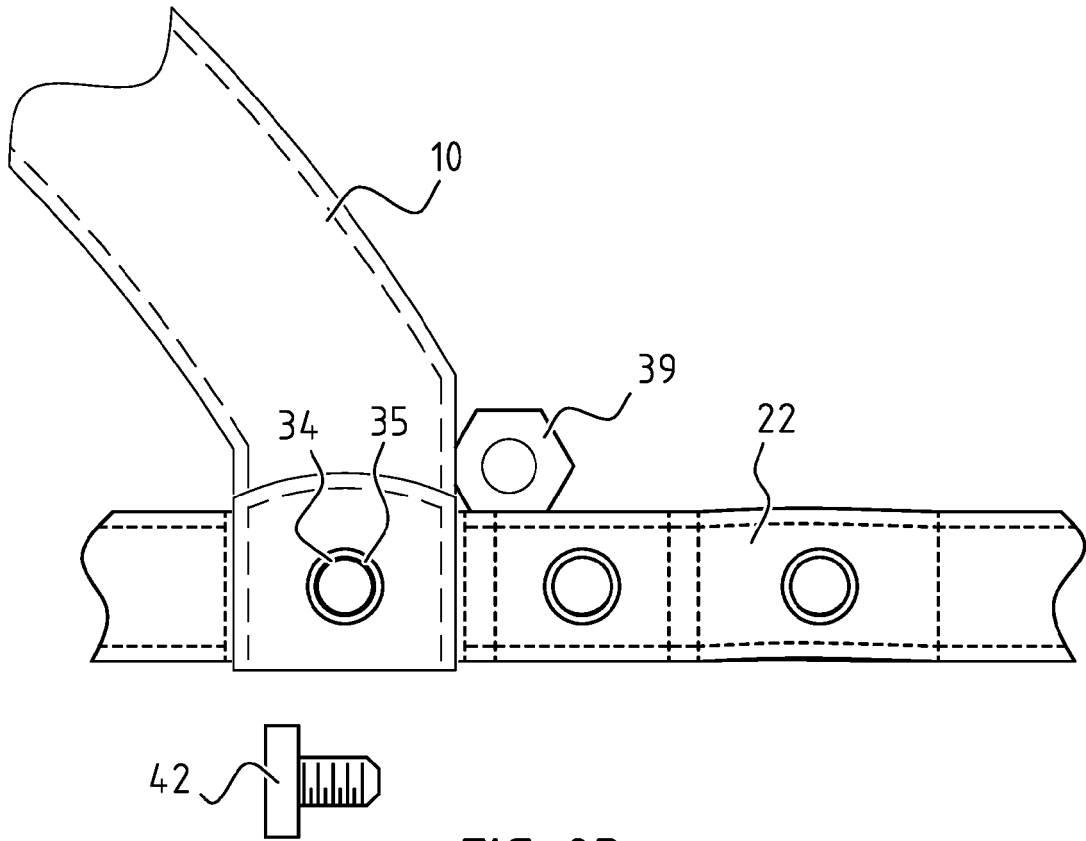

FIG. 9B

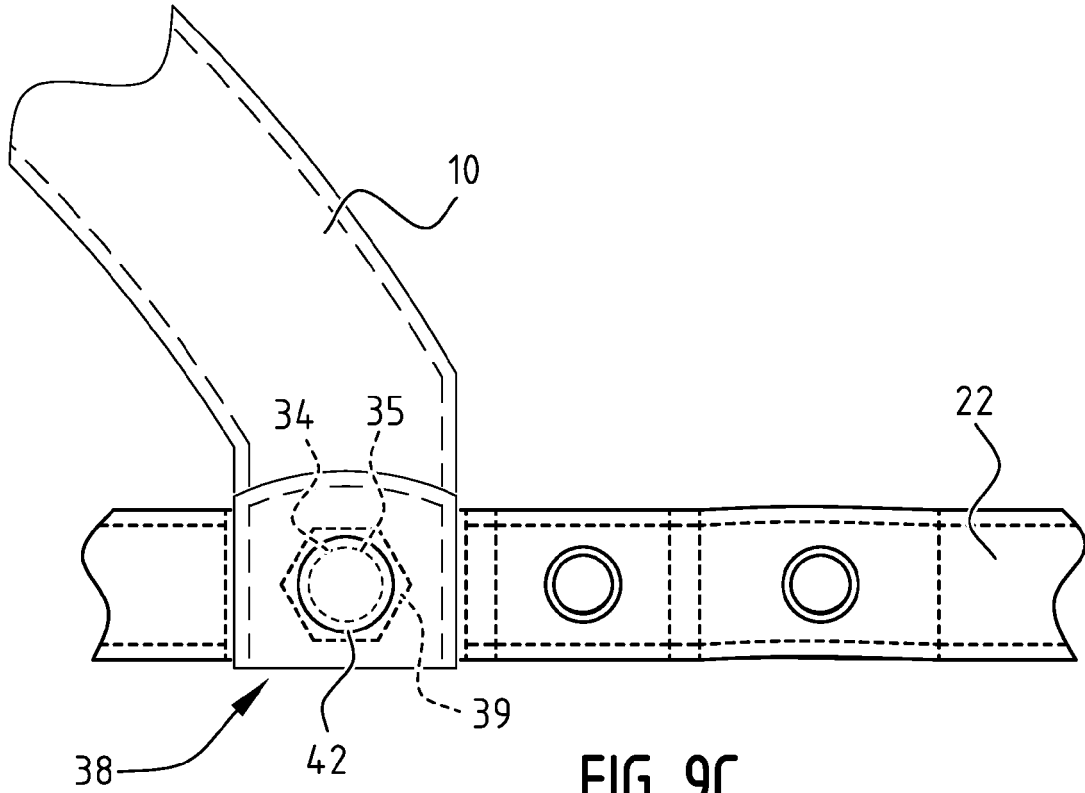

FIG. 9C



EUROPEAN SEARCH REPORT

Application Number
EP 20 17 9575

5

10

15

20

25

30

35

40

45

50

55

DOCUMENTS CONSIDERED TO BE RELEVANT			
Category	Citation of document with indication, where appropriate, of relevant passages	Relevant to claim	CLASSIFICATION OF THE APPLICATION (IPC)
A,D	JP 2002 233408 A (KITADA KK; HOKUTO MFG) 20 August 2002 (2002-08-20) * paragraph [0011] - paragraph [0037]; figures * -----	1-12	INV. A45F3/04 A45C13/26 A45C13/30
A	JP 2006 000382 A (KAZAMA KK) 5 January 2006 (2006-01-05) * figures * -----	1-12	
A	US 3 802 613 A (DROEGER J) 9 April 1974 (1974-04-09) * figure 2 * -----	1-12	
			TECHNICAL FIELDS SEARCHED (IPC)
			A45F A45C B65D
The present search report has been drawn up for all claims			
Place of search The Hague		Date of completion of the search 22 September 2020	Examiner van de Beek-Duijker
CATEGORY OF CITED DOCUMENTS X : particularly relevant if taken alone Y : particularly relevant if combined with another document of the same category A : technological background O : non-written disclosure P : intermediate document		T : theory or principle underlying the invention E : earlier patent document, but published on, or after the filing date D : document cited in the application L : document cited for other reasons & : member of the same patent family, corresponding document	

1
EPO FORM 1503 03.82 (P04C01)

**ANNEX TO THE EUROPEAN SEARCH REPORT
ON EUROPEAN PATENT APPLICATION NO.**

EP 20 17 9575

5 This annex lists the patent family members relating to the patent documents cited in the above-mentioned European search report.
The members are as contained in the European Patent Office EDP file on
The European Patent Office is in no way liable for these particulars which are merely given for the purpose of information.

22-09-2020

10	Patent document cited in search report	Publication date	Patent family member(s)	Publication date
	JP 2002233408	A	20-08-2002	NONE

	JP 2006000382	A	05-01-2006	NONE
15	-----			
	US 3802613	A	09-04-1974	NONE

20				
25				
30				
35				
40				
45				
50				
55				

EPO FORM P0459

For more details about this annex : see Official Journal of the European Patent Office, No. 12/82

REFERENCES CITED IN THE DESCRIPTION

This list of references cited by the applicant is for the reader's convenience only. It does not form part of the European patent document. Even though great care has been taken in compiling the references, errors or omissions cannot be excluded and the EPO disclaims all liability in this regard.

Patent documents cited in the description

- JP 2002233408 A [0004]