

(19)



(11)

EP 3 757 482 B1

(12)

EUROPEAN PATENT SPECIFICATION

(45) Date of publication and mention of the grant of the patent:
24.08.2022 Bulletin 2022/34

(51) International Patent Classification (IPC):
F25B 1/04 ^(2006.01) **F25B 31/02** ^(2006.01)
F25B 43/00 ^(2006.01)

(21) Application number: **20179067.2**

(52) Cooperative Patent Classification (CPC):
F25B 1/04; F25B 31/026; F25B 43/006;
F25B 2500/18

(22) Date of filing: **09.06.2020**

(54) **COMPRESSOR AND HOUSEHOLD APPLIANCE**

KOMPRESSOR UND HAUSHALTSGERÄT

COMPRESSEUR ET APPAREIL MÉNAGER

(84) Designated Contracting States:
AL AT BE BG CH CY CZ DE DK EE ES FI FR GB GR HR HU IE IS IT LI LT LU LV MC MK MT NL NO PL PT RO RS SE SI SK SM TR

(73) Proprietor: **BSH Hausgeräte GmbH**
81739 München (DE)

(30) Priority: **26.06.2019 EP 19382541**

(72) Inventor: **Ruiz Bermejo, Jose Antonio**
26540 Alfaro (La Rioja) (ES)

(43) Date of publication of application:
30.12.2020 Bulletin 2020/53

(56) References cited:
JP-A- 2005 146 987 US-A- 4 194 370
US-A1- 2012 171 066

EP 3 757 482 B1

Note: Within nine months of the publication of the mention of the grant of the European patent in the European Patent Bulletin, any person may give notice to the European Patent Office of opposition to that patent, in accordance with the Implementing Regulations. Notice of opposition shall not be deemed to have been filed until the opposition fee has been paid. (Art. 99(1) European Patent Convention).

Description

[0001] The present invention relates to a compressor for a household appliance and to a household appliance with such a compressor.

[0002] Household appliances like refrigerators, heat pump dryers, heat pump washers, heat pump washer-dryers or heat pump dishwashers comprise a compressor for compressing a gaseous phase of a refrigerant. For storing a liquid phase of the refrigerant, an accumulator can be provided. The accumulator can be placed outside a compressor housing of the compressor.

[0003] US 4,194,370 A describes a gas-liquid separating and liquid storage device for a refrigeration system having a reservoir in which fluid is whirled about an upright axis of said reservoir, an improved gas outlet means disposed centrally of said reservoir comprising an upright tube open at the opposite ends thereof, a cup surrounding at least a portion of said tube and having an open upper end disposed near the upper end of said tube and a bottom wall joined in sealed relation to the exterior of said tube, said bottom wall having at least one liquid metering orifice extending therethrough and a cap mounted on the upper end of said cup, said cup having a top wall overlying the upper end of said tube in spaced relation therefrom with a pressure equalizing vent in said top wall communicating with the space over said tube upper end, said cap also having a sleeve dependent therefrom extending into the annular space defined between said tube and cup with the lower end of said sleeve spaced above said cup bottom wall, said cap top wall having inlet means for communicating the reservoir with the annular space defined between said cup and said cup sleeve, the lower end of said tube serving as the gas exit from said reservoir.

[0004] It is one object of the present invention to provide an improved compressor.

[0005] Accordingly, a compressor for a household appliance is provided. The compressor comprises a compressor housing, wherein the compressor housing receives a compression chamber for compressing a gaseous phase of a refrigerant, and an accumulator for storing a liquid phase of the refrigerant, wherein the accumulator is provided inside the compressor housing. The compressor housing encloses the accumulator and an internal volume which receives the compression chamber, wherein the accumulator comprises a separation wall which separates the accumulator from the internal volume, wherein the accumulator comprises a backing pipe for holding back the liquid phase of the refrigerant in the accumulator, wherein the backing pipe is connected to a suction port of the compressor, wherein the backing pipe is arranged at least partly outside the compressor housing, wherein the backing pipe is guided through the compressor housing, and wherein the backing pipe is connected to the suction port outside the compressor housing.

[0006] Due to the fact that the accumulator is provided

inside the compressor housing, an external accumulator can be avoided. In this way, additional available space around the compressor can be obtained. This improves the space requirements for the compressor which is of significant importance in some applications like heat pump dryers, heat pump washers, heat pump washer-dryers or heat pump dishwashers. Furthermore, the compressor can be produced at lower costs. The cost reduction comes from the fact that when assembling the compressor housing, the accumulator can be integrated into the compressor during assembly of the compressor housing.

[0007] There can also be the case that there is no liquid phase. In this case, the complete refrigerant is in the gaseous phase. This means that the accumulator is only used when the liquid phase has to be stored prior to evaporation thereof. The compressor is able to compress the gaseous phase. The compressor preferably is a rotary compressor or can be named rotary compressor. A "refrigerant" is a substance or mixture, usually a fluid, used in a heat pump and refrigeration cycle. In most cycles it undergoes phase transitions from a liquid to a gas and back again. The gaseous phase can be transferred into the liquid phase and vice versa. The gaseous phase can be named gaseous refrigerant. The liquid phase can be named liquid refrigerant.

[0008] The compressor housing preferably has a cylindrical shape with an outer wall, a bottom cap and a top cap. The caps hermetically close the outer wall at its ends. The compressor housing can be made of steel. The outer wall can be rotation-symmetric to a centerline. The centerline is preferably arranged horizontally so that also the compressor housing is arranged horizontally. However, the compressor can also be arranged vertically. The accumulator uses the bottom cap and part of the outer wall as outer shell. In particular, the accumulator is arranged inside the compressor housing. The centerline can be arranged horizontally or vertically. In other words, the compressor can be a horizontal compressor or a vertical compressor.

[0009] The compressor housing encloses the accumulator and an internal volume which receives the compression chamber, wherein the accumulator comprises a separation wall which separates the accumulator from the internal volume.

[0010] The separation wall prevents the refrigerant from entering the internal volume of the compressor itself. The separation wall can be a steel membrane. A "membrane" is a metal sheet that hermetically seals the compressor from the internal volume. Neither gas nor liquid can pass through the membrane. The membrane can be a steel sheet. The compressor can have a plurality of compressor parts that are necessary to compress the gaseous phase of the refrigerant. The compressor parts can include an electro motor, a steering system, valves, pipes, a discharge port, a piston or pistons, a muffler, a cylinder or the like. The compressor parts are also arranged inside the internal volume.

[0011] According to a further embodiment, the accumulator is provided between the separation wall and a bottom cap of the compressor housing, wherein the bottom cap has an inlet for taking in the gaseous phase and the liquid phase of the refrigerant.

[0012] To provide enough space for the accumulator, the bottom cap can be extended. The inlet can be a pipe that is arranged horizontally or radially to the cylindrical compressor housing.

[0013] According to a further embodiment, the accumulator comprises a filter which is arranged downstream the inlet and inside the compressor housing.

[0014] Both, the gaseous phase and the liquid phase pass through the filter when entering the accumulator. The filter is suitable of removing particles from the liquid phase.

[0015] According to a further embodiment, the filter is cylindrical, wherein the filter is plugged on the inlet.

[0016] For maintenance, the filter is replaceable.

[0017] According to a further embodiment, the filter is plate-shaped, wherein the filter is attached to an end of the inlet.

[0018] The filter is attached to an end of the inlet that protrudes inside the compressor housing. The filter can have a circular shape.

[0019] According to a further embodiment, the inlet comprises an expansion, wherein the filter is attached to an end of the expansion.

[0020] The expansion increases a diameter of the inlet so that the filter has a bigger cross-sectional area. Filtration can be improved in that way.

[0021] According to a further embodiment, the filter is plate-shaped, wherein the filter is attached to the compressor housing.

[0022] In particular, the filter can be attached to the separation wall, the bottom cap and the outer wall of the compressor housing.

[0023] According to a further embodiment, the filter comprises a mesh.

[0024] In particular, the filter comprises a metal mesh or a polymer mesh.

[0025] The accumulator comprises a backing pipe for holding back the liquid phase of the refrigerant in the accumulator.

[0026] The backing pipe retains the liquid phase in the accumulator until it evaporates. The backing pipe allows the gaseous phase to leave the accumulator. In this way, the backing pipe is used for separating the liquid phase from the gaseous phase of the refrigerant. The backing pipe has a bore through which oil for lubricating movable parts of the compressor can pass.

[0027] According to a further embodiment, the accumulator comprises a cover which covers the backing pipe for preventing the liquid phase of the refrigerant from entering the backing pipe and allowing the gaseous phase of the refrigerant to enter the backing pipe.

[0028] The cover is optional. The cover is only used in design cases of the compressor in which the liquid phase

of the refrigerant could directly flow from the inlet into the backing pipe. The cover can be a steel plate. The cover is arranged with a distance from an upper end of the backing pipe so that the gaseous phase can enter the backing pipe. The cover prevents the liquid phase leaving the inlet from directly going into the backing pipe.

[0029] The backing pipe is connected to a suction port of the compressor.

[0030] The suction port can be an internal suction port or an external suction port. "Internal" means that the suction port is arranged inside the compressor housing. "External" means that the suction port is arranged outside the compressor housing. In accordance with the invention the suction port is external.

[0031] Thus, the backing pipe is arranged at least partly outside the compressor housing, wherein the backing pipe is guided through the compressor housing, and wherein the backing pipe is connected to the suction port outside the compressor housing.

[0032] The backing pipe is guided through the compressor housing to the outside.

[0033] All the afore mentioned design options of the compressor can be applied to both, horizontal compressors and vertical compressors.

[0034] Further, a household appliance comprising such a compressor is provided.

[0035] The household appliance can be a laundry dryer, a dishwasher, a refrigerator, a deep freezer or the like. In the case that the household appliance is a laundry dryer or a dishwasher, the compressor can be part of a heat pump. In particular, the household appliance can be a heat pump dryer, a heat pump washer, a heat pump washer-dryer or a heat pump dishwasher.

[0036] Further possible implementations or alternative solutions of the invention also encompass combinations - that are not explicitly mentioned herein - of features described above or below with regard to the embodiments. The person skilled in the art may also add individual or isolated aspects and features to the most basic form of the invention.

[0037] Further embodiments, features and advantages of the present invention will become apparent from the subsequent description and dependent claims, taken in conjunction with the accompanying drawings, in which:

Fig. 1 shows a schematic perspective view of one embodiment of a household appliance;

Fig. 2 shows a cross-sectional view of one embodiment of a compressor for the household appliance according to Fig. 1;

Fig. 3 shows an enlarged view of the compressor according to the view III of Fig. 2;

Fig. 4 shows a further cross-sectional view of the compressor according to the intersection line IV-IV of Fig. 2;

Fig. 5 shows a further cross-sectional view of the compressor according to the intersection line V-V of Fig. 4;

Fig. 6 shows a cross-sectional view of a further embodiment of a compressor for the household appliance according to Fig. 1;

Fig. 7 shows a further cross-sectional view of the compressor according to the intersection line VII-VII of Fig. 6;

Fig. 8 shows a cross-sectional view of a further embodiment of a compressor for the household appliance according to Fig. 1;

Fig. 9 shows a cross-sectional view of a further embodiment of a compressor for the household appliance according to Fig. 1; and

Fig. 10 shows a cross-sectional view of a further embodiment of a compressor for the household appliance according to Fig. 1.

[0038] In the Figures, like reference numerals designate like or functionally equivalent elements, unless otherwise indicated.

[0039] Fig. 1 shows a schematic perspective view of one embodiment of a household appliance 1. The household appliance 1 can be a laundry dryer, a dishwasher, a refrigerator, a deep freezer or the like. The household appliance 1 has a housing 2 comprising a bottom 3, a ceiling 4 which is arranged opposite the bottom 3, two opposing side walls 5, 6 and a back wall 7. The housing 2 is cuboid-shaped. The housing 2 has a front wall 8 which opposes the back wall 7. A door 9 is provided at the front wall 8 which can be opened to put laundry or other items into the household appliance 1. In this case, the household appliance 1 is a front loader. The door 9 can also be provided at the ceiling 4. In this case, the household appliance 1 is a top loader.

[0040] Fig. 2 shows a cross-sectional view of one embodiment of a compressor 10 for the household appliance 1. Fig. 3 shows an enlarged view of the compressor 10 according to the view III of Fig. 2. Fig. 4 shows a further cross-sectional view of the compressor 10 according to the intersection line IV-IV of Fig. 2. Fig. 5 shows a further cross-sectional view of the compressor 10 according to the intersection line V-V of Fig. 4. In the following, Figs. 2 to 5 are referred to at the same time.

[0041] In the case that the household appliance 1 is a laundry dryer or a dishwasher, the compressor 10 is part of a heat pump. The compressor 10 is a rotary compressor. In particular, the compressor 10 is a horizontal rotary compressor. The compressor 10 comprises a compressor housing 11. The compressor housing 11 receives movable parts (not shown) of the compressor 10 which are used to compress a gaseous phase GR of a refrigerant.

A "refrigerant" is a substance or mixture, usually a fluid, used in a heat pump and refrigeration cycle. In most cycles it undergoes phase transitions from a liquid to a gas and back again. The refrigerant also has a liquid phase LR. The gaseous phase GR can be transferred into the liquid phase LR and vice versa. The gaseous phase GR can be named gaseous refrigerant. The liquid phase LR can be named liquid refrigerant.

[0042] The compressor housing 11 has a cylindrical outer wall 12 which can be rotation-symmetric to a centerline 13. The compressor housing 11 further has a bottom cap 14 and a top cap 15 which hermetically close the outer wall 12 at its ends. In use of the compressor 10, the centerline 13 is arranged horizontally as shown in Fig. 2.

[0043] In the compressor housing 11, an accumulator 16 for storing the liquid phase LR of the refrigerant is received. The accumulator 16 uses parts of the compressor housing 11 as outer shell. The accumulator 16 is part of the compressor 10. The accumulator 16 is dedicated to store the liquid phase LR of the refrigerant before entering the compressor 10 itself. This is because only the gaseous phase GR but not the liquid phase LR can be compressed. The compressor housing 11 has an internal volume 17 which comprises the afore-mentioned movable parts of the compressor 10. In other words, the parts of the compressor 10 that are necessary for the compressing function of the compressor 10 are arranged inside the internal volume 17. The internal volume 17 is separated from the accumulator 16 by means of a separation wall 18. The separation wall 18 is a hermetic sealed wall which fluidly separates the accumulator 16 from the internal volume. No fluid can pass through the separation wall 18 itself. The separation wall 18 can be made of steel.

[0044] As can be seen from Figs. 2, 3 and 5, the accumulator 16 has an inlet 19 which can be provided on top of the bottom cap 14. The gaseous phase GR of the refrigerant and the liquid phase LR of the refrigerant can enter the accumulator 16 through the inlet 19. The inlet 19 can be a pipe that is arranged parallel to the centerline 13. The inlet 19 can be welded to the bottom cap 14. The inlet 19 is arranged horizontally. The inlet 19 can also be arranged radially to the housing 11.

[0045] The accumulator 16 comprises a backing pipe 20 which prevents the liquid phase LR from entering an external suction port (not shown) of the compressor 10, in particular from entering a compression chamber 23 of the compressor 10, and allows only the gaseous phase GR of the refrigerant entering it. The backing pipe 20 holds back the liquid phase LR in the accumulator 16. The backing pipe 20 is arranged at least partly inside the accumulator 16. For this reason, the backing pipe 20 can be named internal pipe. The backing pipe 20 is arranged perpendicular to the centerline 13 and runs therefore vertically. The backing pipe 20 breaks through the outer wall 12 of the compressor housing 11. The backing pipe 20 is connected to the afore mentioned external suction port

of the compressor 10. The backing pipe 20 has a bore (not shown) through which oil for lubricating movable parts of the compressor 10 can pass.

[0046] The accumulator 16 comprises a filter 21. The filter 21 is capable of removing particles like dust from the liquid phase LR of the refrigerant when entering the accumulator 16 through the inlet 19. The filter 21 is plate-shaped. The filter 21 can be a mesh, in particular a metal mesh, that is connected to the outer wall 12, the bottom cap 14 and the separation wall 18. The filter 21 is arranged horizontally. In particular, the filter 21 is arranged perpendicular to the backing pipe 20.

[0047] The accumulator 16 further has an optional cover 22. The cover 22 is plate-shaped and covers the backing pipe 20 such that the liquid phase LR of the refrigerant entering the accumulator 16 through the inlet 19 cannot enter the backing pipe 20 directly. The cover 22 can be a steel plate. The cover 22 can have a circular, a rectangular or any other suitable shape. The cover 22 can be connected to the filter 21 so that the filter 21 and the cover 22 form a single component. The cover 22 can be also connected to the outer wall 12. For example, the cover 22 can be welded to the outer wall 12. The cover 22 is arranged with a distance from an upper end of the backing pipe 20.

[0048] Now returning back to Fig. 2, the compressor 10 comprises the compression chamber 23 which is arranged inside the internal volume 17 or is part of the internal volume 17. In the compression chamber 23, the gaseous phase GR of the refrigerant is compressed. The compression chamber 23 has a suction port 24 which takes in the gaseous phase GR of the refrigerant. The suction port 24 can be a pipe. As mentioned before, the suction port 24 can be an external suction port. In this case, the suction port 24 is guided through the compressor housing 11. The suction port 24 is then connected to the backing pipe 20 outside the compressor housing 11.

[0049] However, as will be mentioned later, the suction port 24 can also be an internal suction port. In this case, the suction port 24 is not guided through the compressor housing 11. Rather, the suction port 24 is connected to the backing pipe 20 inside the compressor housing 11. The compressor 10 has a plurality of compressor parts 25 that are necessary to compress the gaseous phase GR of the refrigerant. The compressor parts 25 can include an electro motor, a steering system, valves, pipes, a discharge port or the like.

[0050] The function of the compressor 10 is as follows. The gaseous phase GR of the refrigerant enters the accumulator 16 through the inlet 19. In case that there is also the liquid phase LR of the refrigerant, the liquid phase LR also enters the accumulator 16 through the inlet 19. However, it is also possible that there is no liquid phase LR. This is the case when all the refrigerant is in the gaseous phase GR. Both, the liquid phase LR and the gaseous phase GR pass through the filter 21, wherein particles can be removed from the liquid phase LR. The cover 22, which is in this case needed, prevents the liquid

phase LR from entering the backing pipe 20 directly. The gaseous phase GR of the refrigerant can be directly fed to the suction port 24 by means of the backing pipe 20. In this case, the suction port 24 is an external suction port. The liquid phase LR is stored in the accumulator 16 until it evaporates and enters the suction port 24 of the compressor 10 through the backing pipe 20 as gaseous phase GR. In this way, the liquid phase LR is separated from the gaseous phase GR of the refrigerant.

[0051] Due to the fact that the accumulator 16 is arranged inside the compressor housing 11, an external accumulator can be avoided. In this way, additional available space around the compressor 10 can be obtained. This improves the space requirement for the compressor 10 which is very important in some applications like heat pump dryers, heat pump washers, heat pump washer-dryers or heat pump dishwashers. Furthermore, the compressor 10 can be produced at lower costs. The cost reduction comes from the fact that the assembly of the bottom cap 14 can be done in the same way as it is done currently. However, when assembling the bottom cap 14, the accumulator 16 can be integrated into the compressor 10.

[0052] Figs. 6 and 7 show cross-sectional views of a further example of the compressor 10 not belonging to the invention.

[0053] The example of the compressor 10 according to Figs. 6 and 7 differs from the embodiment of the compressor 10 according to Figs. 2 to 5 only in that the backing pipe 20 is not connected to an external suction port but to an internal suction port (not shown) of the compressor 10. The backing pipe 20 is connected to an outlet 26 of the accumulator 16. The outlet 26 is a pipe that is arranged horizontally. The outlet 26 is connected to the suction port 24 of the compressor 10. In this case, the suction port 24 is an internal suction port. The outlet 26 is guided through the separation wall 18. In other words, the backing pipe 20 is guided through the separation wall 18 by means of the outlet 26.

[0054] Fig. 8 shows a cross-sectional view of a further embodiment of the compressor 10. The embodiment of the compressor 10 according to Fig. 8 differs from the embodiment of the compressor 10 according to Figs. 2 to 5 only in that the filter 21 is not plate-shaped. The filter 21 has a cylindrical geometry and is plugged on the inlet 19. The filter 21 is a cylindrical mesh. As can be seen from Fig. 8, the inlet 19 is arranged in a distance from the backing pipe 20. Thus, in the layout shown in Fig. 8, the cover 22 can be dispensable because the backing pipe 20 is placed so far away from the inlet 19 that the liquid phase LR of the refrigerant cannot directly reach the backing pipe 20. As shown in Fig. 8, the inlet 19 itself can run straight horizontally. Alternatively, the inlet 19 can have a bend downwards so that the inlet 19 at least partly runs vertically (not shown).

[0055] Fig. 9 shows a cross-sectional view of a further embodiment of the compressor 10. The embodiment of the compressor 10 according to Fig. 9 differs from the

embodiment of the compressor 10 according to Figs. 2 to 5 only in that the filter 21 is directly attached to an end of the inlet 19 that extends into the accumulator 16. The filter 21 is plate-shaped. The filter 21 can have a circular shape. The filter 21 is a mesh. As can be seen from Fig. 9, the inlet 19 is arranged in a distance from the backing pipe 20. Thus, in the layout shown in Fig. 9, the cover 22 can be dispensable because the backing pipe 20 is placed so far away from the inlet 19 that the liquid phase LR of the refrigerant cannot directly reach the backing pipe 20. As shown in Fig. 9, the inlet 19 itself can run straight horizontally. Alternatively, the inlet 19 can have a bend downwards so that the inlet 19 at least partly runs vertically (not shown).

[0056] Fig. 10 shows a cross-sectional view of a further embodiment of the compressor 10. The embodiment of the compressor 10 according to Fig. 10 differs from the embodiment of the compressor 10 according to Fig. 9 only in that the inlet 19 comprises a cone-shaped expansion 27 that extends into the accumulator 16. The filter 21 is attached to the expansion 27. The filter 21 is plate-shaped. The filter 21 can have a circular shape. The filter 21 is a mesh. The expansion 27 increases a diameter of the inlet 19 so that the filter 21 has a bigger cross-sectional area. Filtration can be improved in that way.

[0057] As can be seen from Fig. 10, the inlet 19 is arranged in a distance from the backing pipe 20. Thus, in the layout shown in Fig. 10, the cover 22 can be dispensable because the backing pipe 20 is placed so far away from the inlet 19 that the liquid phase LR of the refrigerant cannot directly reach the backing pipe 20. As shown in Fig. 10, the inlet 19 itself can run straight horizontally. Alternatively, the inlet 19 can have a bend downwards so that the inlet 19 at least partly runs vertically (not shown).

[0058] Although the present invention has been described in accordance with preferred embodiments, it is obvious for the person skilled in the art that modifications are possible in all embodiments.

Reference Numerals:

[0059]

- 1 household appliance
- 2 housing
- 3 bottom
- 4 ceiling
- 5 side wall
- 6 side wall
- 7 back wall
- 8 front wall
- 9 door
- 10 compressor
- 11 compressor housing
- 12 outer wall
- 13 centerline
- 14 bottom cap

- 15 top cap
- 16 accumulator
- 17 internal volume
- 18 separation wall
- 5 19 inlet
- 20 backing pipe
- 21 filter
- 22 cover
- 23 compression chamber
- 10 24 suction port
- 25 compressor part
- 26 outlet
- 27 expansion
- 15 GR gaseous phase
- LR liquid phase

Claims

- 20 1. A compressor (10) for a household appliance (1), comprising a compressor housing (11), wherein the compressor housing (11) receives a compression chamber (23) for compressing a gaseous phase (GR) of a refrigerant, and an accumulator (16) for storing a liquid phase (LR) of the refrigerant, wherein the accumulator (16) is provided inside the compressor housing (11), wherein the compressor housing (11) encloses the accumulator (16) and an internal volume (17) which receives the compression chamber (23), and wherein the accumulator (16) comprises a separation wall (18) which separates the accumulator (16) from the internal volume (17), wherein the accumulator (16) comprises a backing pipe (20) for holding back the liquid phase (LR) of the refrigerant in the accumulator (16), **characterised in that** the backing pipe (20) is connected to a suction port (24) of the compressor (10), wherein the backing pipe (20) is arranged at least partly outside the compressor housing (11), wherein the backing pipe (20) is guided through the compressor housing (11), and wherein the backing pipe (20) is connected to the suction port (24) outside the compressor housing (11).
- 25
- 30
- 35
- 40
- 45 2. The compressor according to claim 1, wherein the accumulator (16) is provided between the separation wall (18) and a bottom cap (14) of the compressor housing (11), and wherein the bottom cap (14) has an inlet (19) for taking in the gaseous phase (GR) and the liquid phase (LR) of the refrigerant.
- 50
- 55 3. The compressor according to claim 2, wherein the accumulator (16) comprises a filter (21) which is arranged downstream the inlet (19) and inside the compressor housing (11).
- 4. The compressor according to claim 3, wherein the

filter (21) is cylindrical, and wherein the filter (21) is plugged on the inlet (19).

5. The compressor according to claim 3, wherein the filter (21) is plate-shaped, and wherein the filter (21) is attached to an end of the inlet (19). 5
6. The compressor according to claim 5, wherein the inlet (19) comprises an expansion (27), and wherein the filter (21) is attached to an end of the expansion (27). 10
7. The compressor according to claim 3, wherein the filter (21) is plate-shaped, and wherein the filter (21) is attached to the compressor housing (11). 15
8. The compressor according to one of claims 3 - 7, wherein the filter (21) comprises a mesh.
9. The compressor according to one of claims 1 - 8, wherein the accumulator (16) comprises a cover (22) which covers the backing pipe (20) for preventing the liquid phase (LR) of the refrigerant from entering the backing pipe (20) and allowing the gaseous phase (GR) of the refrigerant to enter the backing pipe (20). 20 25
10. A household appliance (1) comprising a compressor (10) according to one of claims 1 - 9. 30

Patentansprüche

1. Kompressor (10) für ein Haushaltsgerät (1), der ein Kompressorgehäuse (11) umfasst, wobei das Kompressorgehäuse (11) eine Kompressionskammer (23) zum Komprimieren einer Gasphase (GR) eines Kältemittels enthält und einen Speicher (16) zum Speichern einer Flüssigphase (LR) des Kältemittels, wobei der Speicher (16) in dem Kompressorgehäuse (11) vorgesehen ist, wobei das Kompressorgehäuse (11) den Speicher (16) und ein Innenvolumen (17) umgibt, das die Kompressionskammer (23) enthält, und wobei der Speicher (16) eine Trennwand (18) umfasst, die ihn von dem Innenvolumen (17) trennt, wobei der Speicher (16) eine Rückhalteleitung (20) zum Zurückhalten der Flüssigphase (LR) des Kältemittels im Speicher (16) umfasst, **dadurch gekennzeichnet, dass** die Rückhalteleitung (20) mit einem Sauganschluss (24) des Kompressors (10) verbunden ist, wobei die Rückhalteleitung (20) zumindest teilweise außerhalb des Kompressorgehäuses (11) angeordnet ist, durch das Kompressorgehäuse (11) führt und außerhalb des Kompressorgehäuses (11) mit dem Sauganschluss (24) verbunden ist. 35 40 45 50 55
2. Kompressor nach Anspruch 1, wobei der Speicher

(16) zwischen der Trennwand (18) und einem unteren Verschluss (14) des Kompressorgehäuses (11) vorgesehen ist und der untere Verschluss (14) einen Einlass (19) zum Einlassen der Gasphase (GR) und der Flüssigphase (LR) des Kältemittels aufweist.

3. Kompressor nach Anspruch 2, wobei der Speicher (16) einen Filter (21) umfasst, der nach dem Einlass (19) und im Kompressorgehäuse (11) angeordnet ist.
4. Kompressor nach Anspruch 3, wobei der Filter (21) zylinderförmig und auf den Einlass (19) aufgesteckt ist.
5. Kompressor nach Anspruch 3, wobei der Filter (21) plattenförmig und an einem Ende des Einlasses (19) angebracht ist.
6. Kompressor nach Anspruch 5, wobei der Einlass (19) eine Aufweitung (27) umfasst und der Filter (21) an einem Ende der Aufweitung (27) angebracht ist.
7. Kompressor nach Anspruch 3, wobei der Filter (21) plattenförmig und an dem Kompressorgehäuse (11) angebracht ist.
8. Kompressor nach einem der Ansprüche 3 bis 7, wobei der Filter (21) ein Sieb umfasst.
9. Kompressor nach einem der Ansprüche 1 bis 8, wobei der Speicher (16) eine Abdeckung (22) umfasst, die die Rückhalteleitung (20) abdeckt, um zu verhindern, dass die Flüssigphase (LR) des Kältemittels in die Rückhalteleitung (20) einströmt, und zu ermöglichen, dass die Gasphase (GR) des Kältemittels in die Rückhalteleitung (20) einströmen kann.
10. Haushaltsgerät (1) mit einem Kompressor (10) nach einem der Ansprüche 1 bis 9.

Revendications

1. Compresseur (10) pour un appareil ménager (1), comprenant un logement de compresseur (11), dans lequel le logement de compresseur (11) reçoit une chambre de compression (23) pour comprimer une phase gazeuse (GR) d'un réfrigérant, et un accumulateur (16) pour stocker une phase liquide (LR) du réfrigérant, dans lequel l'accumulateur (16) est prévu à l'intérieur du logement de compresseur (11), dans lequel le logement de compresseur (11) contient l'accumulateur (16) et un volume interne (17) qui reçoit la chambre de compression (23), et dans lequel l'accumulateur (16) comprend une paroi de séparation (18) qui sépare l'accumulateur (16) du volume interne (17), dans lequel l'accumulateur (16)

- comprend un tuyau de refoulement (20) pour retenir la phase liquide (LR) du réfrigérant dans l'accumulateur (16), **caractérisé en ce que** le tuyau de refoulement (20) est connecté à un orifice d'aspiration (24) du compresseur (10), dans lequel le tuyau de refoulement (20) est agencé au moins partiellement à l'extérieur du logement de compresseur (11), dans lequel le tuyau de refoulement (20) est guidé au travers du logement de compresseur (11) et dans lequel le tuyau de refoulement (20) est connecté à l'orifice d'aspiration (24) à l'extérieur du logement de compresseur (11). 5 10
2. Compresseur selon la revendication 1, dans lequel l'accumulateur (16) est prévu entre la paroi de séparation (18) et un capuchon de fond (14) du logement de compresseur (11), et dans lequel le capuchon de fond (14) comporte une entrée (19) pour l'admission de la phase gazeuse (GR) et de la phase liquide (LR) du réfrigérant. 15 20
3. Compresseur selon la revendication 2, dans lequel l'accumulateur (16) comprend un filtre (21) qui est agencé en aval de l'entrée (19) et à l'intérieur du logement de compresseur (11). 25
4. Compresseur selon la revendication 3, dans lequel le filtre (21) est cylindrique, et dans lequel le filtre (21) est branché sur l'entrée (19). 30
5. Compresseur selon la revendication 3, dans lequel le filtre (21) est en forme de plaque, et dans lequel le filtre (21) est fixé sur une extrémité de l'entrée (19).
6. Compresseur selon la revendication 5, dans lequel l'entrée (19) comprend une chambre d'expansion (27), et dans lequel le filtre (21) est fixé sur une extrémité de la chambre d'expansion (27). 35
7. Compresseur selon la revendication 3, dans lequel le filtre (21) est en forme de plaque, et dans lequel le filtre (21) est fixé sur le logement de compresseur (11). 40
8. Compresseur selon l'une quelconque des revendications 3 à 7, dans lequel le filtre (21) comprend un maillage. 45
9. Compresseur selon l'une quelconque des revendications 1 à 8, dans lequel l'accumulateur (16) comprend un moyen de recouvrement (22) qui recouvre le tuyau de refoulement (20) pour empêcher que la phase liquide (LR) du réfrigérant ne pénètre à l'intérieur du tuyau de refoulement (20) et pour permettre que la phase gazeuse (GR) du réfrigérant pénètre à l'intérieur du tuyau de refoulement (20). 50 55
10. Appareil ménager (1) comprenant un compresseur (10) selon l'une quelconque des revendications 1 à 9.

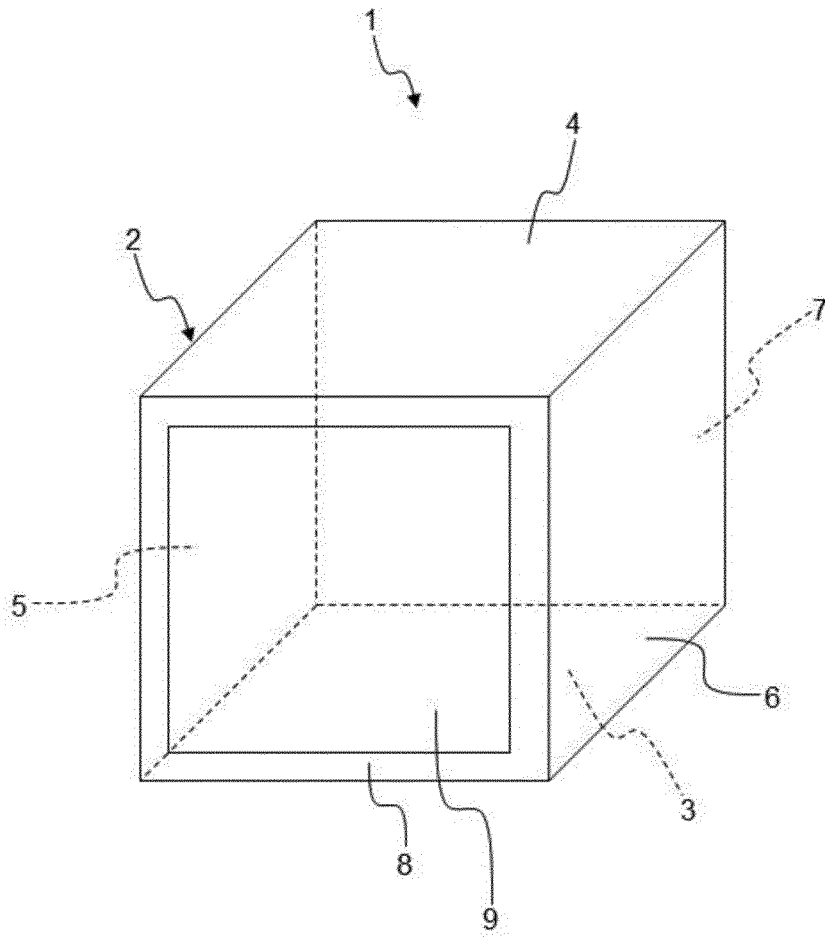

Fig. 1

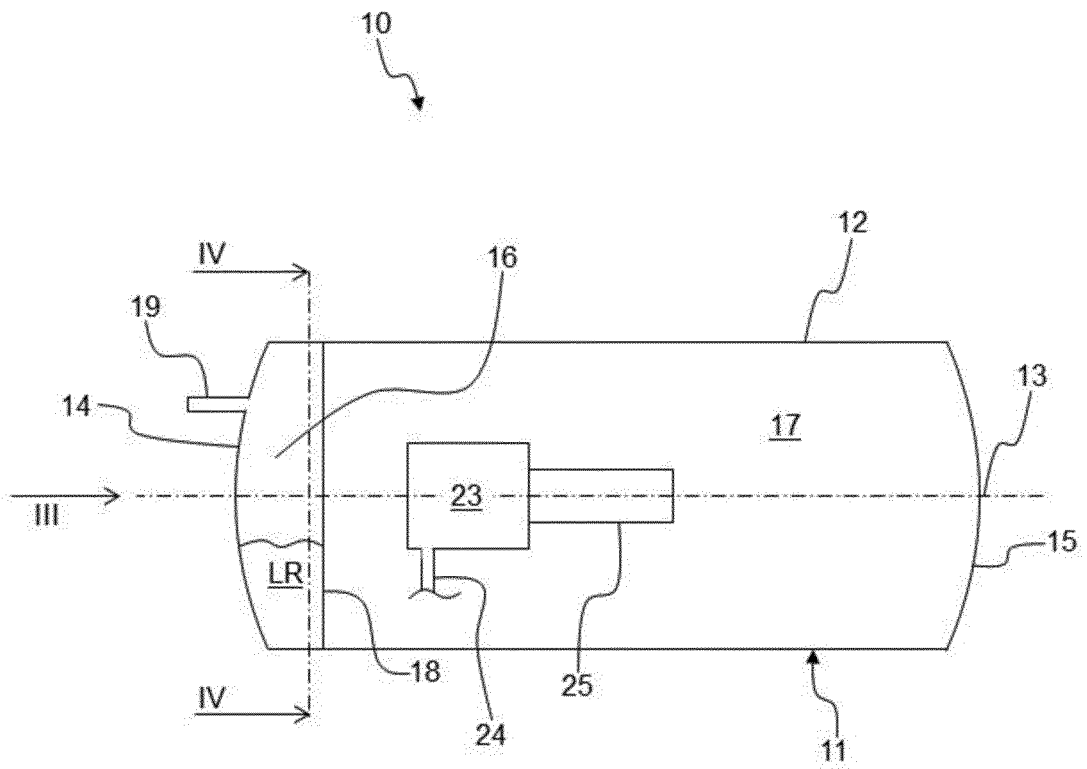

Fig. 2

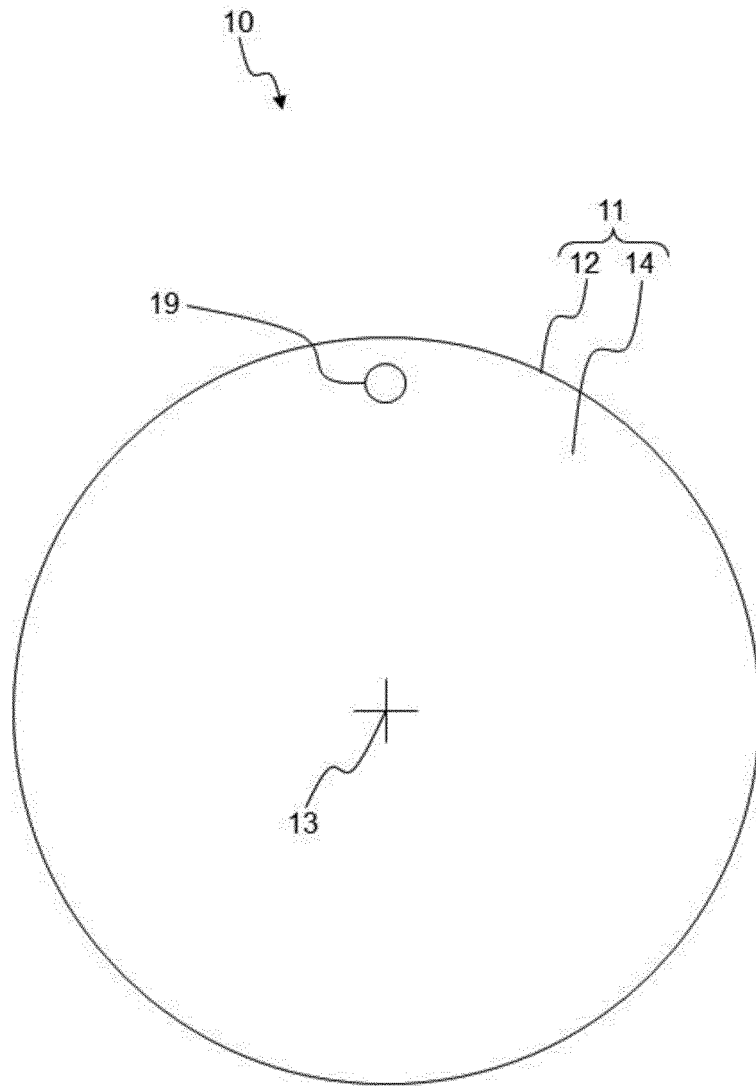

Fig. 3

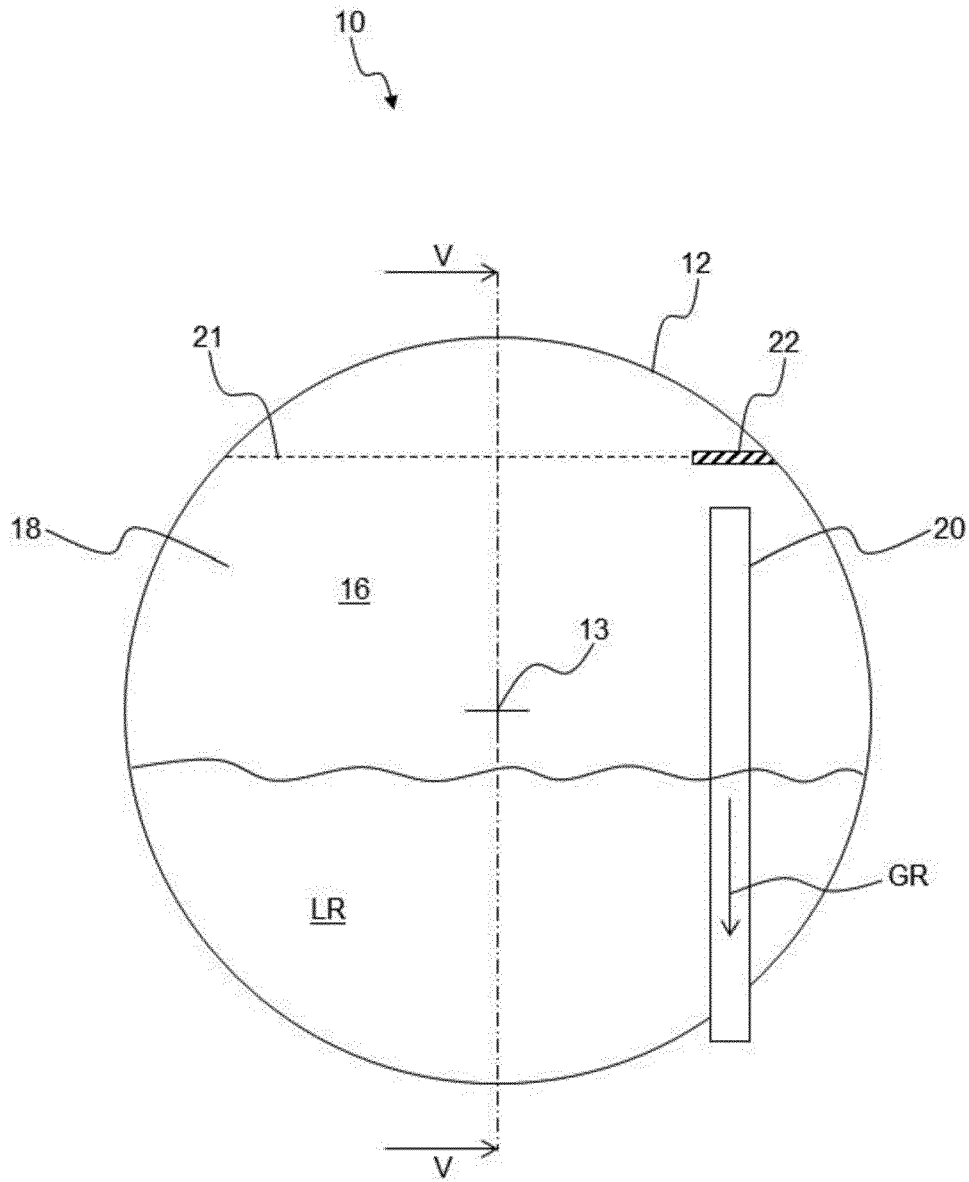

Fig. 4

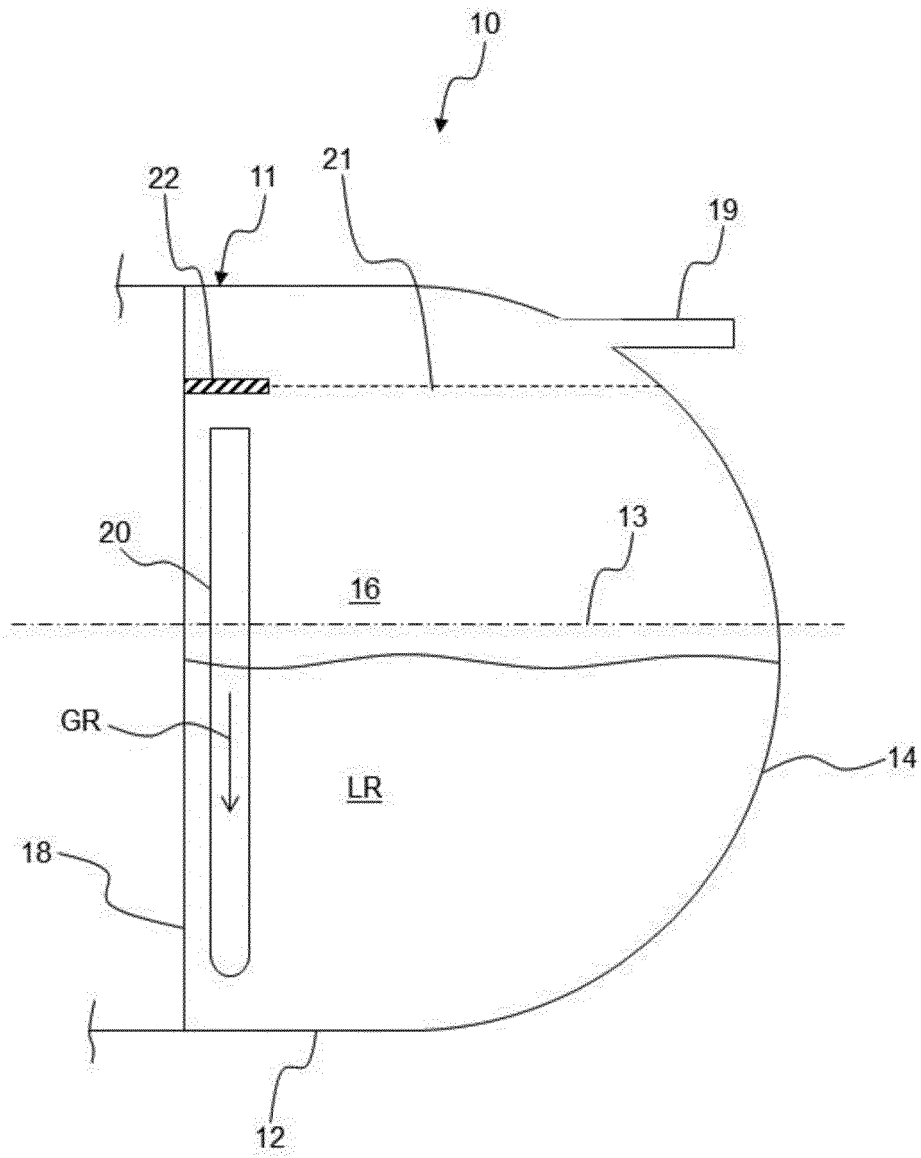

Fig. 5

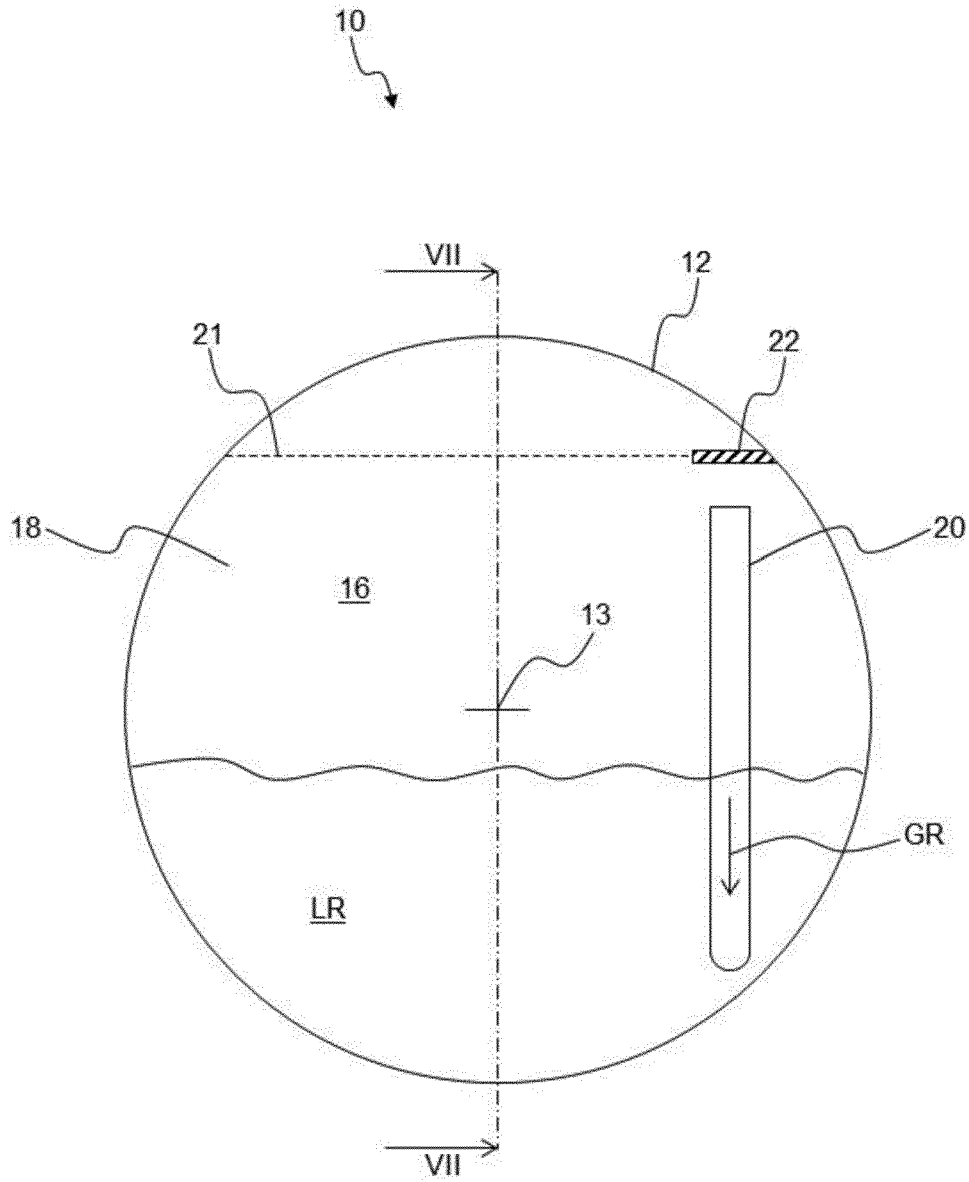

Fig. 6

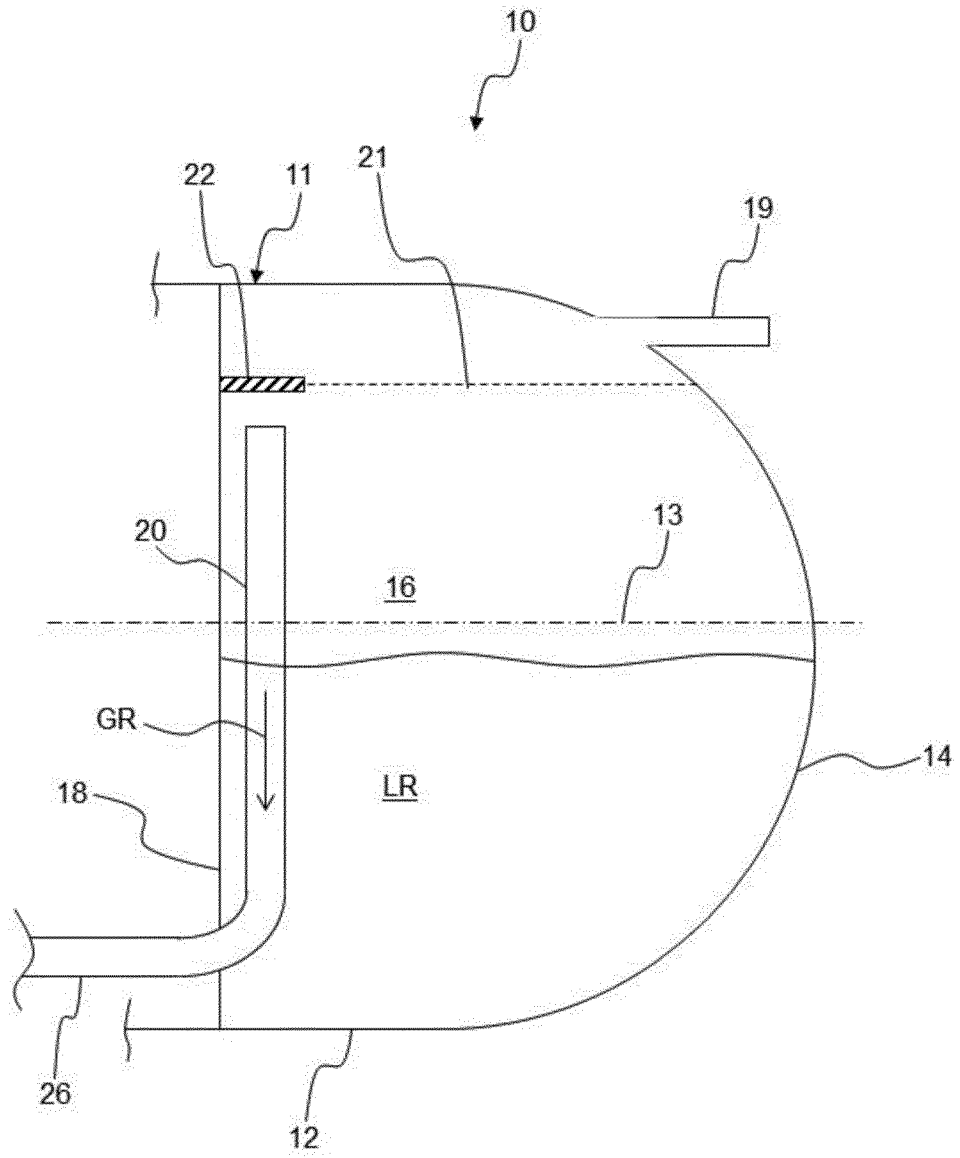

Fig. 7



Fig. 8

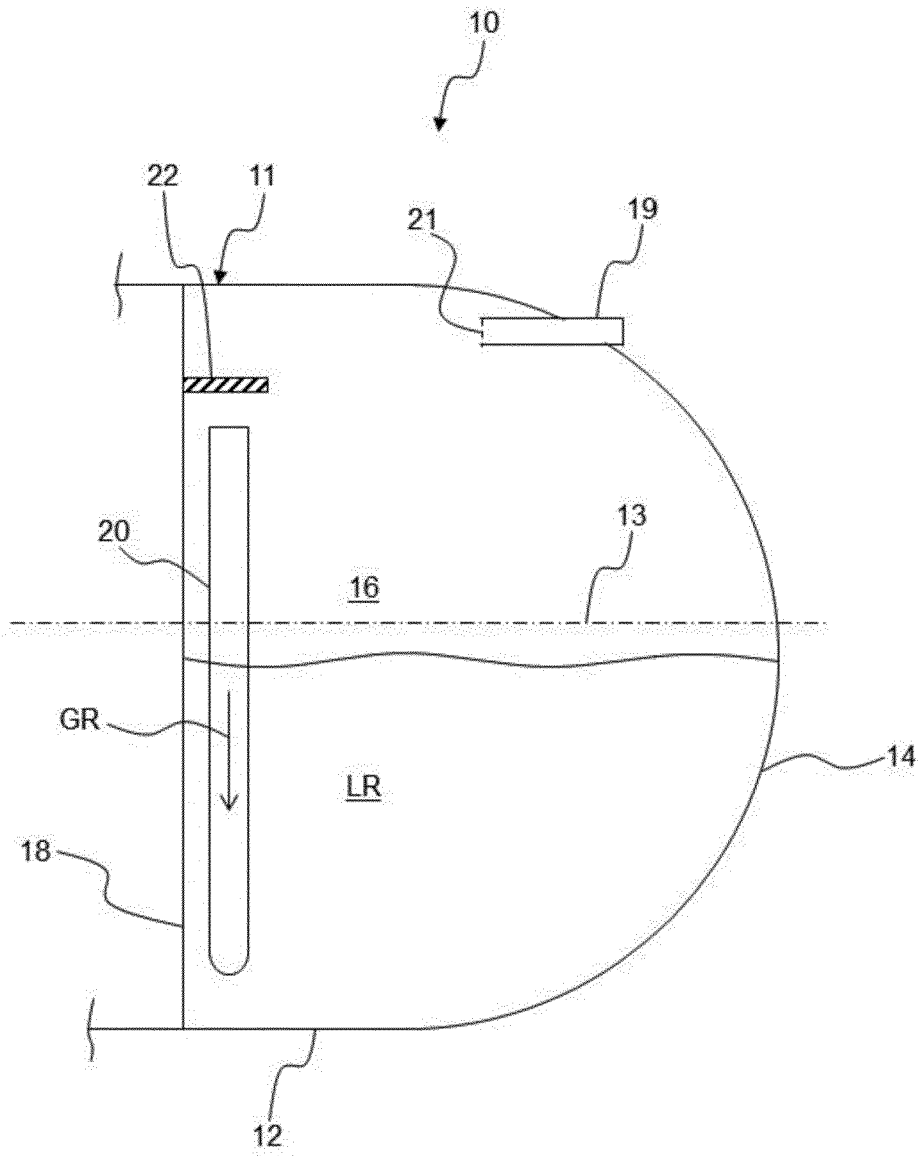

Fig. 9

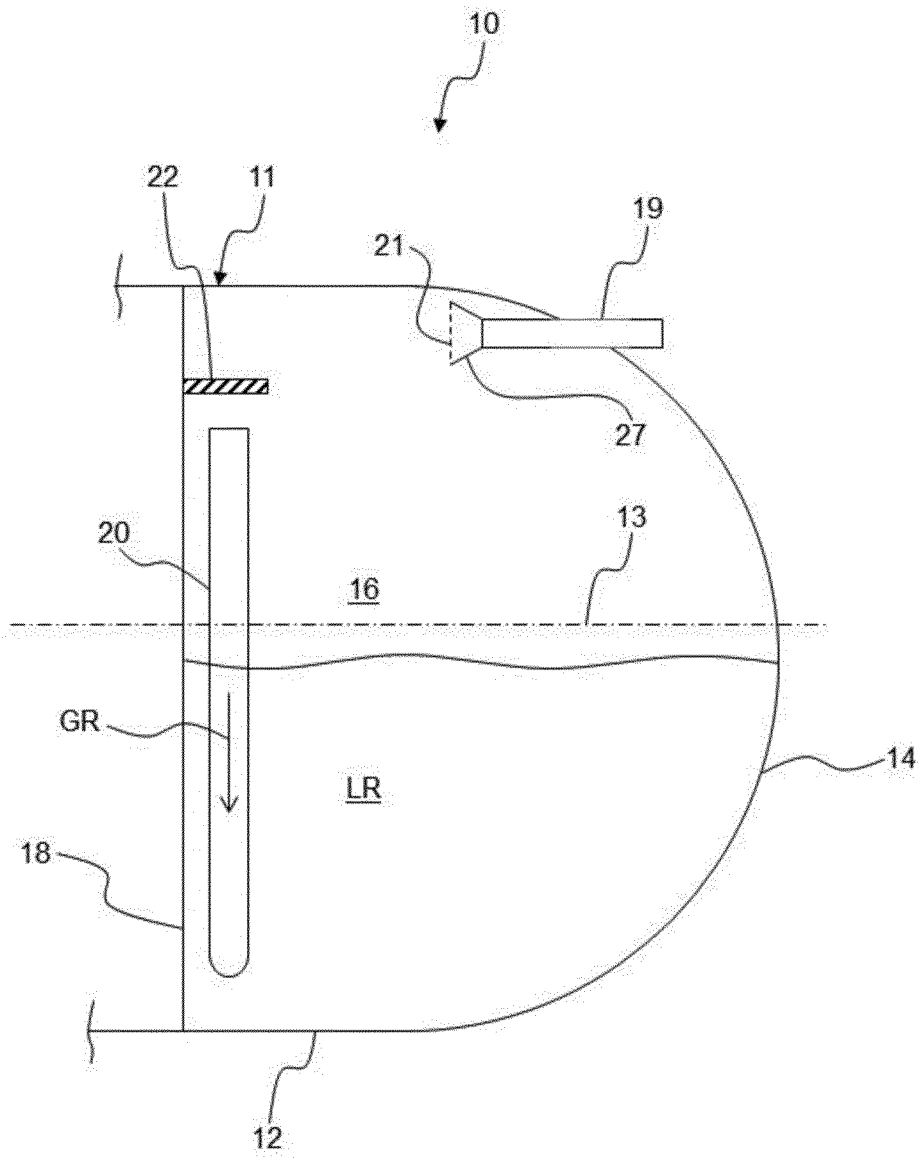

Fig. 10

REFERENCES CITED IN THE DESCRIPTION

This list of references cited by the applicant is for the reader's convenience only. It does not form part of the European patent document. Even though great care has been taken in compiling the references, errors or omissions cannot be excluded and the EPO disclaims all liability in this regard.

Patent documents cited in the description

- US 4194370 A [0003]