

(19)



(11)

EP 3 757 505 A1

(12)

EUROPEAN PATENT APPLICATION

(43) Date of publication:
30.12.2020 Bulletin 2020/53

(51) Int Cl.:
F41H 5/02 (2006.01)

(21) Application number: **19461550.6**

(22) Date of filing: **28.06.2019**

(84) Designated Contracting States:
**AL AT BE BG CH CY CZ DE DK EE ES FI FR GB
 GR HR HU IE IS IT LI LT LU LV MC MK MT NL NO
 PL PT RO RS SE SI SK SM TR**
 Designated Extension States:
BA ME
 Designated Validation States:
KH MA MD TN

(72) Inventors:
 • **LITWIN, Lukasz**
63-440 Rasków (PL)
 • **STARCZEWSKI, Lech**
05-070 Sulejówek (PL)
 • **SZUDROWICZ, Marek**
05-074 Nowy Konik, gm. Halinów (PL)
 • **SZCZESNIAK, Krzysztof**
05-070 Sulejówek (PL)
 • **GMITRZUK, Michal**
03-890 Warszawa (PL)

(71) Applicants:
 • **LUBAWA S.A.**
63-400 Ostrów Wielkopolski (PL)
 • **Wojskowy Instytut Techniki Panczernej i
 Samochodowej**
05-070 Sulejówek (PL)

(74) Representative: **Malcherek, Piotr**
Rzecznicy Patentowi INVENT Sp. z o.o.
ul. Gen. Ch. de Gaulle'a 8
43-100 Tychy (PL)

(54) **A BALISTIC PROTECTIVE NET MODULE**

(57) A module of ballistic net (1) provided to protect vehicles, structures or other facilities against consequences of impacts effected by hits of armour-piercing rocket-propelled grenades ejected by grenade launchers. The module net (1) comprises cords (2, 3), where the mutually crossing cords (2, 3) are joined together at the locations of intersections of cords (2) and cords (3) by means of connectors (4). An individual connector (4) comprises a body (5) having a bottom plane (6) shaped in the form of a quadrangle, in particular a square, and a top plane (7). Side walls (8) of the body (5) have the form of regular trapeziums and converge towards the top plane (7) of the body down the full height of the body (5). Side edges (9) in between of mutually adjacent side walls (8) are inclined against the height (h) of the connector (4) body (5) at the angle (α) selected from the range from 2.5° to 5°. The arrangement of connectors (4) joined to cords (2,3) of the net enables displacement of connectors (4) outwardly in relation to the mesh of the net (1) when a grenade hits the net, which leads to destruction of the external shell of a grenade hitting the net (1) by means of inclined side edges (9) of connectors (4).

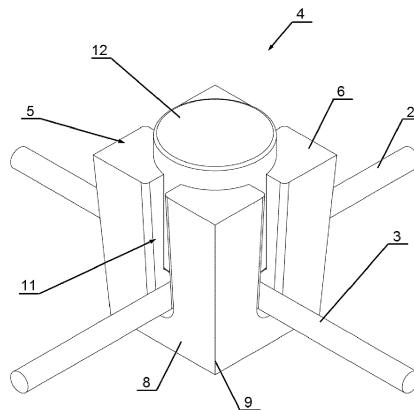

Fig. 2

EP 3 757 505 A1

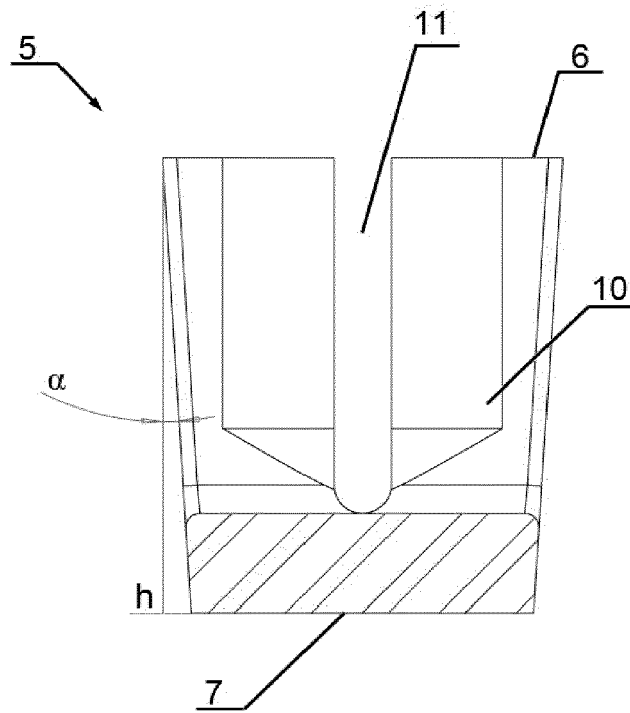

Fig. 4

Description

Subject of the invention

[0001] The invention refers to a module of a ballistic net that comprises mutually crossing net cords as well as connectors designed to join intersecting cords of the net, whereas such a net is meant to protect vehicles, structures or other facilities against consequences of impacts effected by hits of armour-piercing rocket-propelled grenades (RPG) ejected by grenade launchers.

State of the art

[0002] The patent description WO2014/065924 discloses a module of a ballistic net provided with a frame designed to support a net made up of mutually crossing cords. The net cords are stretched between frame components or boundary tubular members that are designed to fix the net to the frame. Connectors are provided at points of cords intersections and designed so that to enable throughout passage of intersecting cords. A module of the ballistic net discloses a connecting element which includes a multi-sided body having a hexagon base, with an open cavity therein and with two pairs of slots made in side walls of the connecting element. The pairs of slots are positioned in mutually opposite fashion so that to receive cords of the net. Net cords are pushed into two pairs of slots and then secured by means of a tightly fitted plug designed to fix positions of intersecting net cords and lock their mutual positions.

[0003] In turn, document US2010/0288114A1 discloses a similar module of a ballistic net provided with connectors of various shapes. For instance, the description discloses a connector that has the shape of a polyhedral body with an octagonal base and a flat bottom side of the body has two mutually crosswise slots designed to receive net cords pushed therein in tightly fitted manner. The opposite base of the connector has a shaped tip with bevelled side walls. Therefore the net cords are fixed to connectors at the net intersections. Consequently a portion of a grenade can pass through the net meshes but its remaining parts is at least partly fragmented by edges of connectors.

[0004] Also EP2662657 discloses a module of ballistic net designed to protect buildings and vehicles. Similarly, it is also the solution where flexible and mutually intersecting cords are stretched on a frame. The frame itself is fixed to the protected facility by means of brackets that enable adjustment of the distance between the ballistic net and the facility. At the locations of flexible cords intersections connectors are provided in the form of hard points designed to penetrate outer shells of grenades that hit the ballistic net. The hard points are shaped in a special manner so that they tumble and angle inwardly towards the net meshes at the moment of grenade hits, which entails destruction of outer grenade shells and penetration of their interiors. The hard points are provided

with cavities or longitudinal slots to enable fixation of net cords, nevertheless other design of hard points is disclosed as well, where the hard points have slots for cords provided on the both base planes so that such connectors make up a kind of a spacer between two nets stretched on the frame. Yet another design of a connector is disclosed as well, provided with slots for cords and a cavity for a stud that makes up a kind of a plug designed to fix the cords. In particular, connectors of polyhedral shape are disclosed, where corners of the polyhedral embodiment of these connectors are designed to penetrate outer shells of grenades.

[0005] Moreover, EP2780657 disclosed a module of ballistic net designed for protection of buildings and vehicles. Flexible cords that make up a net are stretched on a frame that is fixed to the protected facilities. Special connectors are provided at selected locations of cords intersections designed to receive intersecting cords. The connector bodies have a cavity located beyond their front surface. The cavity receives intersecting cords with interference fit, which are secured with a plug, whereas a protrusion is provided on the front plane of the connector body. These connectors are meant to destruct shells of grenades hitting the ballistic net, therefore connectors and protrusions on their front planes can be of various shapes suitable for that purpose. This solution discloses various shapes of connectors, including ones with cylindrical or octagonal shapes as well as ones with additional edges and provided with tapered plugs.

[0006] Furthermore, the application description PL126568U for an utility model discloses a module of ballistic net with boundaries designed to mount the module on a frame. A net made of cords is stretched between the boundaries, and the intersecting cords are fixed together at the points of intersections by means of connectors. Each single connector has a shape of a polyhedral body with an internal cavity designed to receive a plug inserted with interference fit. Side walls of the body are provided with slots, open at their tops and designed to receive cords, where these slots are located in pairs, opposite one to another. The connector body has a base plane of quadrangle shape and slots are located in centre of each side wall of the body, whilst the end section of the cavity in the connector body has converging surfaces, whereas the plug itself has a cylindrical form and ends up with a tapered tip.

Aim of the invention

[0007] The invention is aimed to provide a new design of a ballistic net module to improve efficiency of grenade destruction and to enable easy manufacturing and installation.

[0008] The invention refers specifically to a module of ballistic net for protection of vehicles, structures or other facilities against hits of rocket propelled grenades (RPG) ejected by grenade launchers, according to the preamble of the independent claim. The essence of the invention

consists in that the bodies of connectors have bottom plane in the form of a rectangle, in particular a square, whilst side walls of these connectors have the form of regular trapezium and converge towards the top plane of the body down the full height of the connector, whereas edges in between of side walls are inclined against the height of the connector at the angle ranging from $2,5^\circ$ to 5° . Consequently, the layout of connectors combined with net cords guarantees that hit of grenade leads to displacement of connectors outwards with simultaneous pivoting of them and tilted side edges of connectors pierce and destruct outer shells of grenade hitting the net.

[0009] The module of a ballistic net according to the present invention comprises connectors that reliably fix intersecting cords of the net and enable easy assembling and installation. But first and foremost, side walls of connectors are inclined down its full height, which facilitates targeting of the grenade cone into the net mesh and, at the same time, inclined side edges of connectors squeeze the grenade cone down its full length and break the grenade shell, which improves efficiency of the outer shell destruction. When a grenade hits the net according to the present invention, connectors are pushed away and pivoted outwardly, which leads to incision of the outer shell of the grenade by inclined edges of connectors. Therefore the outer shell of the grenade is penetrated down a much longer distance, which improves efficiency of the grenade destruction and prevents from its explosion. In addition, the top plane surface area of the connector body is reduced at the net side exposed to shooting, i.e. where the grenades arrive from, which enlarges the surface area of the net mesh and also increases the probability that the grenade tip enters the net mesh. Another desirable effect is also associated with the less surface area at the site of grenade impacts, which reduces that probability that the grenade explodes due to impacting a net connector hard point.

Drawing and embodiment

[0010] The invention shall be explained in details by the following embodiment and accompanying drawings, in which:

fig. 1 illustrates the net module in a schematic front view,

fig. 2 is a schematic isometric view of the connector with intersecting cords and the locking plug,

fig. 3 presents projection view of the connector body from the bottom side,

fig. 4 is a cross-section of the connector body down the A-A plane in fig. 3,

fig. 5 presents projection view of the connector body from the top side,

fig. 6 is a side view of the locking plug,

fig. 7 is an isometric view of the locking plug,

5 fig. 8 is a half-section schematic longwise view of the connector body with the plug in place,

10 fig. 9 is a graphic schematic explanation of the ballistic net safeguarding effect during subsequent phases of a grenade hit as seen from the side of protected facility, and

15 fig. 10 is a graphic schematic explanation of the ballistic net safeguarding effect during subsequent phases of a grenade hit as shown in the longwise section.

[0011] A module of ballistic net 1 designed to protect vehicles, structures and other facilities against consequences of impacts effected by hits of armour-piercing rocket-propelled grenades (RPG) ejected by grenade launchers, comprises mutually crossing cords 2 and 3 that make up a net. The cords 2 and 3 can be made, for instance, of aramid fibres and preferably coated with a polyester material. The net 1 is fixed to a frame that is not shown on the drawing. The cords 2 and 3 at the points of mutual intersections are joined together by means of connectors 4 that can be made for instance of steel or composite materials. Each single connector 4 has a body 5 shaped in the form of a polyhedral with a bottom plane 6 with the quadrangular shape, in particular a square, and a top plane 7. Side walls 8 have the form of regular trapezium and converge towards the top plane 7 of the body down the full height h of the body 5 of the connector 4, whereas side edges 9 in between of mutually adjacent side walls 8 are inclined against the height h of the connectors' body 5 at the angle α selected from the range from 2.5° to 5° , for instance 3.6° . The bottom plane 6 facing the protected facility has an internal cavity 10. In addition, the side walls 8 have slots 11 made at the elevation of the internal cavity 10. These slots are open at the side of the bottom plane and designed to receive cords 2 and 3. After placing the cords 2 and 3 in slots 11, the cavity 10 is filled with a locking plug 12 tightly fitted into the cavity.

[0012] Fig. 9 and fig. 10 explain subsequent phases of the net 1 behaviour after it is hit by a grenade. The arrangement of connectors 4 joined to cords 2 and 3 in sliding and pivoted manner enables displacement of connectors 4 outwardly with respect to the net mesh when a grenade hits the net, which leads to destruction of the external shell of a grenade hitting the net 1 by means of inclined side edges 9 of connectors 4.

[0013] Detailed parameters of the net, for instance diameters and number of cords as well as distances between adjacent cords or degree of connector density within the net module can be determined by experiments depending on specific purpose of ballistic net modules

according to the present invention.

Reference numbers

[0014]

1 - module of ballistic net	5
2 - cords	
3 - cords	10
4 - connector	
5 - body of the connector	15
6 - bottom plane	
7 - top plane	
8 - side walls	20
9 - side edges	
10 - cavity in the bottom plane	25
11 - slots in side walls	
12 - plug	30
h - height of the connector	
α - inclination angle between the side edge of the connector body to its height	35

in the form of a quadrangle, in particular a square, whilst the side walls (8) have the form of regular trapeziums and converge towards the top plane (7) of the body down the full height of the body (5) of the connector (4), whereas side edges (9) in between of mutually adjacent side walls (8) are inclined against the height (h) of the body (5) of the connector (4) at the angle (α) selected from the range from 2.5° to 5° so that the arrangement of connectors (4) joined to cords (2,3) of the net enables displacement of connectors (4) outwardly when a grenade hits the net, which leads to destruction of the external shell of a grenade hitting the net (1) by means of inclined side edges (9) of connectors (4).

Claims

1. A module of ballistic net (1) provided to protect vehicles, structures or other facilities against consequences of impacts effected by hits of armour-piercing rocket-propelled grenades ejected by grenade launchers, where the module comprises cords (2, 3) that make up the net (1), where the mutually crossing cords (2, 3) are joined together at the locations of intersections of cords (2) and cords (3) by means of connectors (4) and each individual connector (4) comprises a body (5) shaped in the form of polyhedral and having a bottom plane (6), side walls (8) and top plane (7), whereas the bottom plane (6) facing the facility to be protected has an internal cavity (10) designed to receive a plug (12) tightly fitted into the cavity (10) and meant to lock cords (2, 3) of the net (1), whilst side walls (8) have slots (11) made at the elevation of the internal cavity (10), open at the side of the bottom plane (6) and designed to receive cords (2, 3), **characterized in that** single body (5) of the connector (4) has its bottom plane (6) shaped

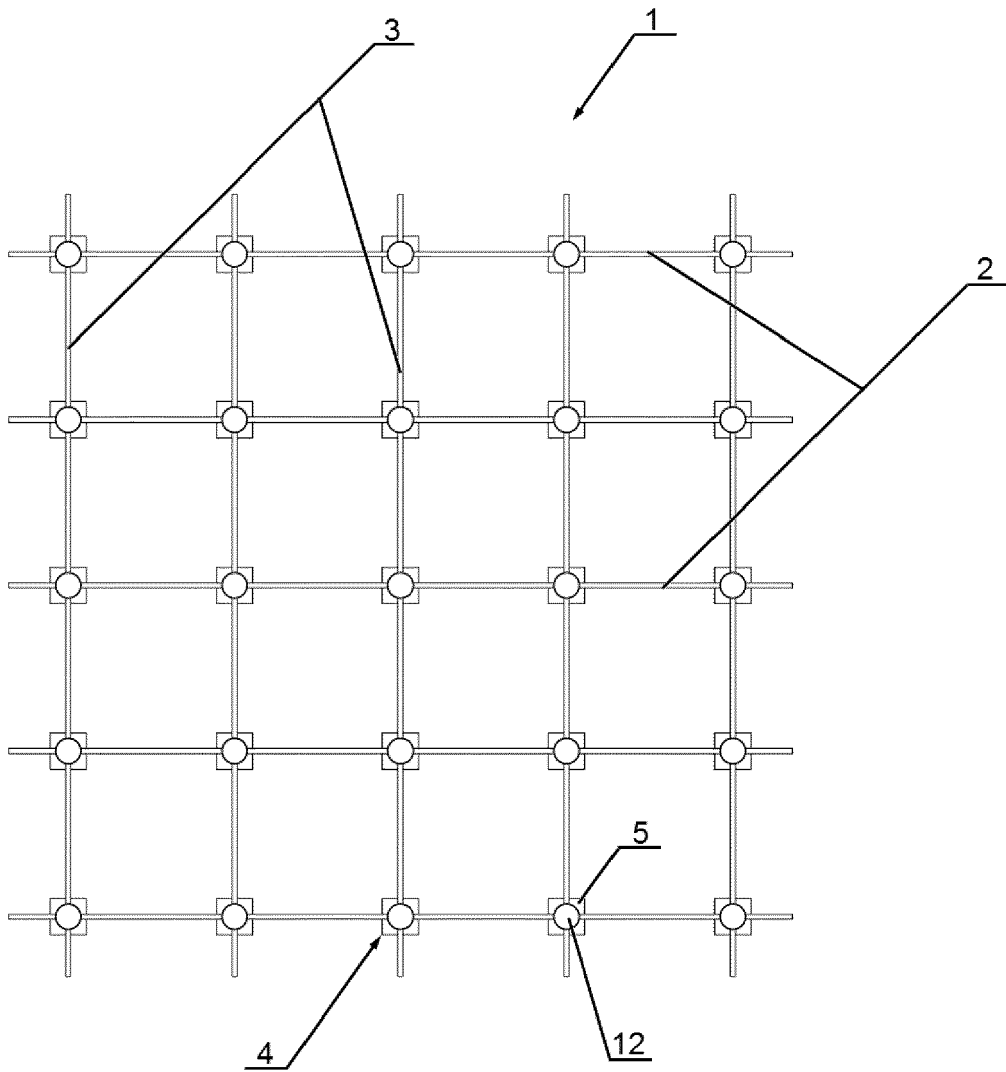

Fig. 1

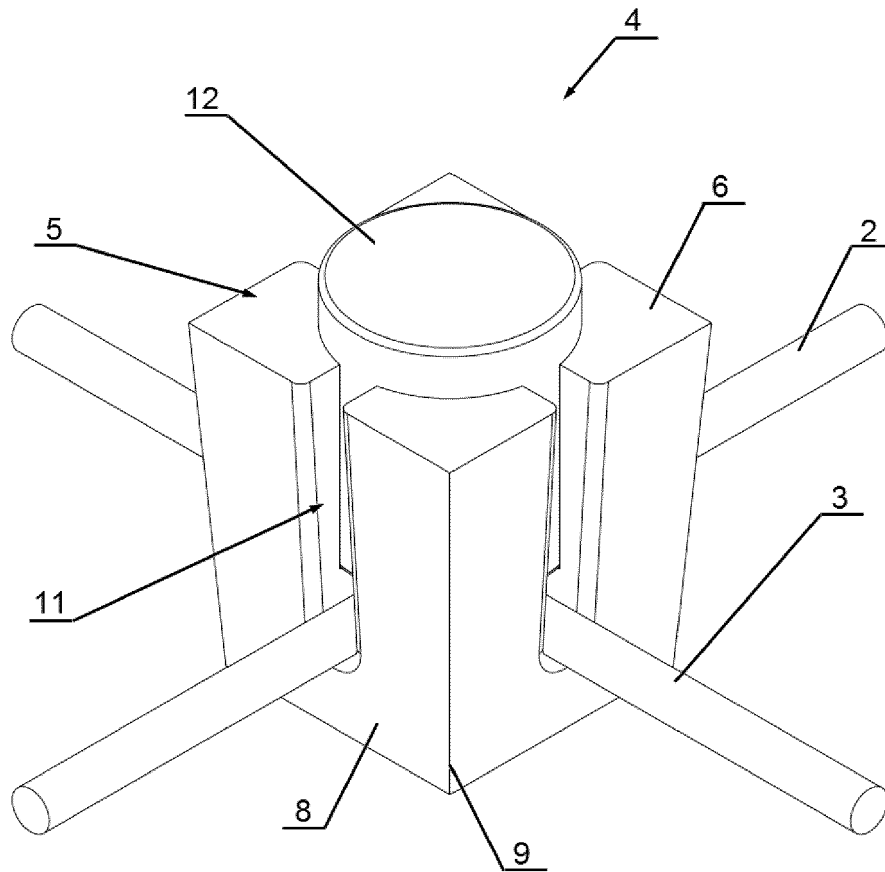

Fig. 2

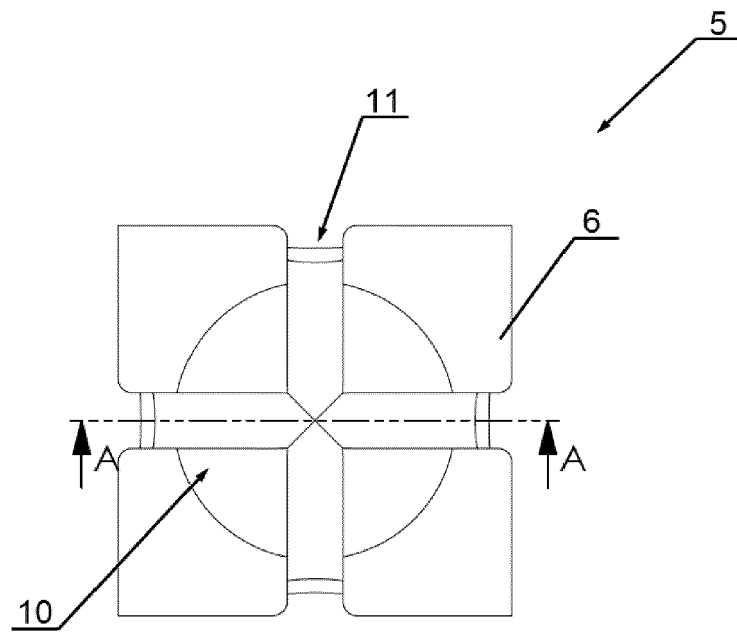

Fig. 3

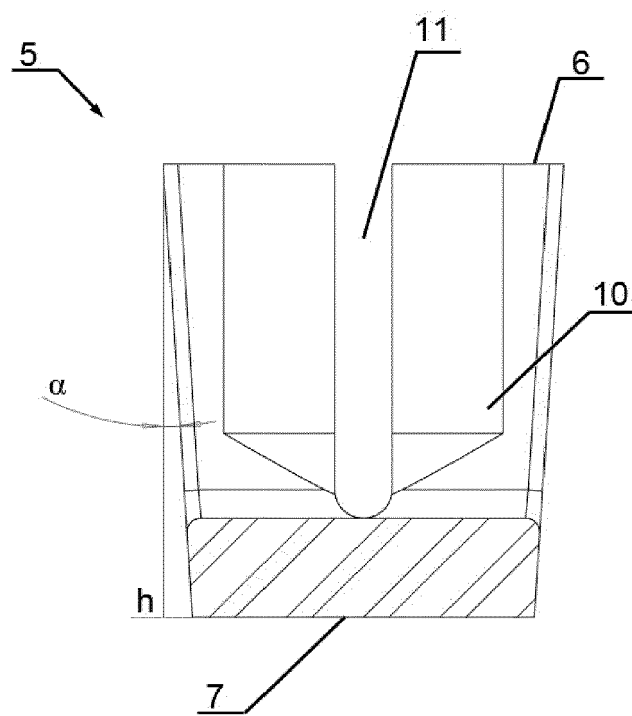

Fig. 4

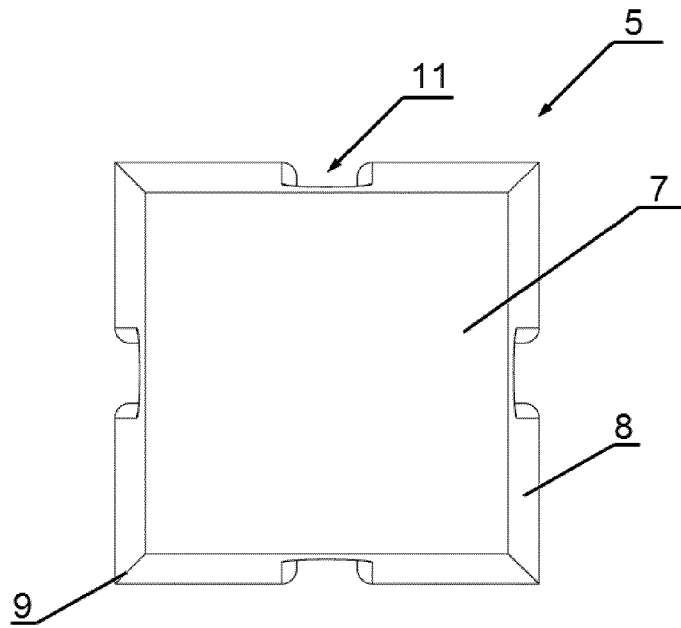

Fig. 5

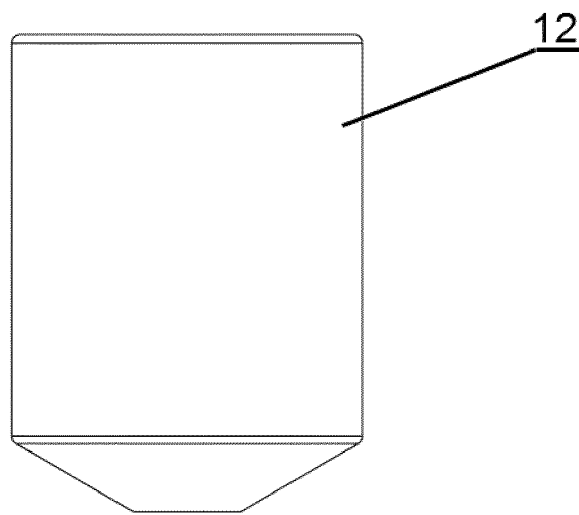

Fig. 6

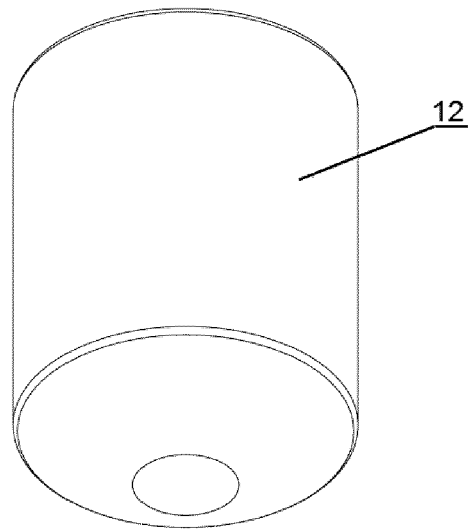

Fig. 7

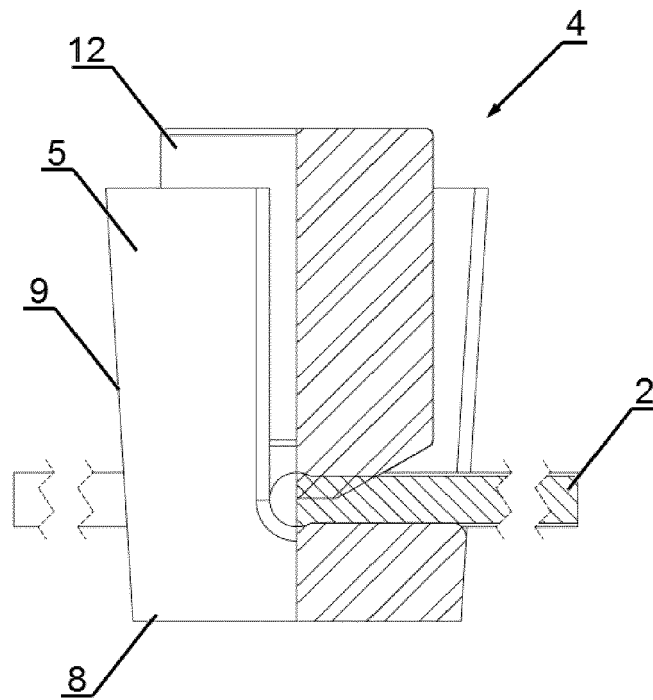

Fig. 8

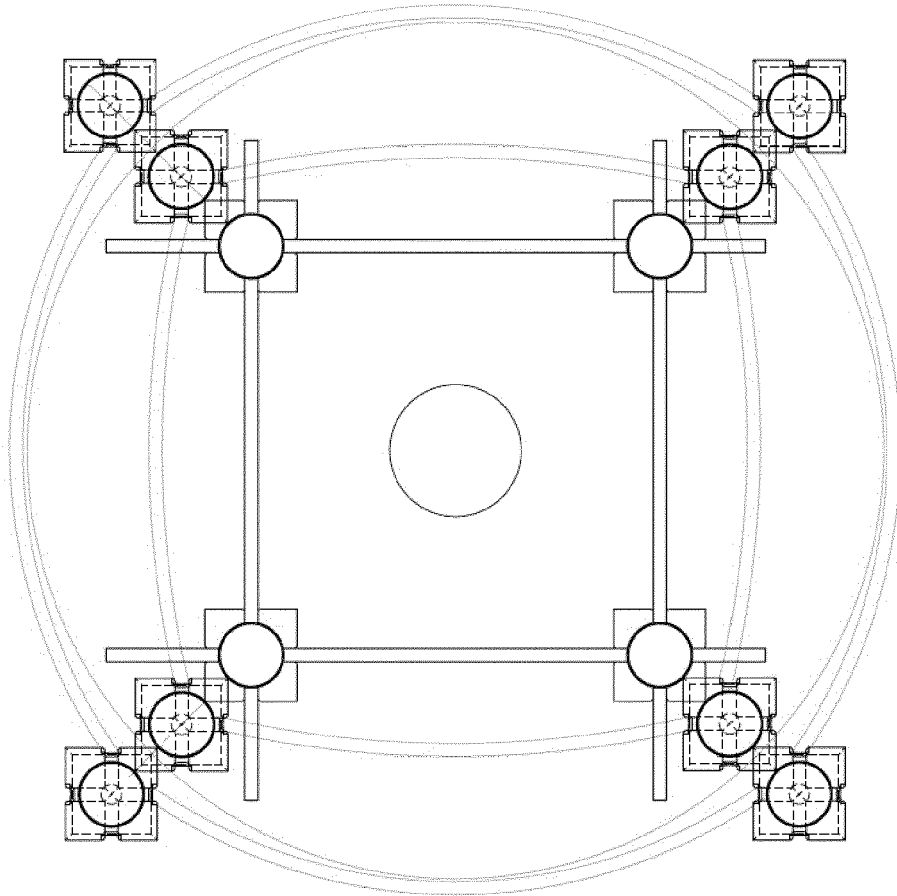

Fig. 9

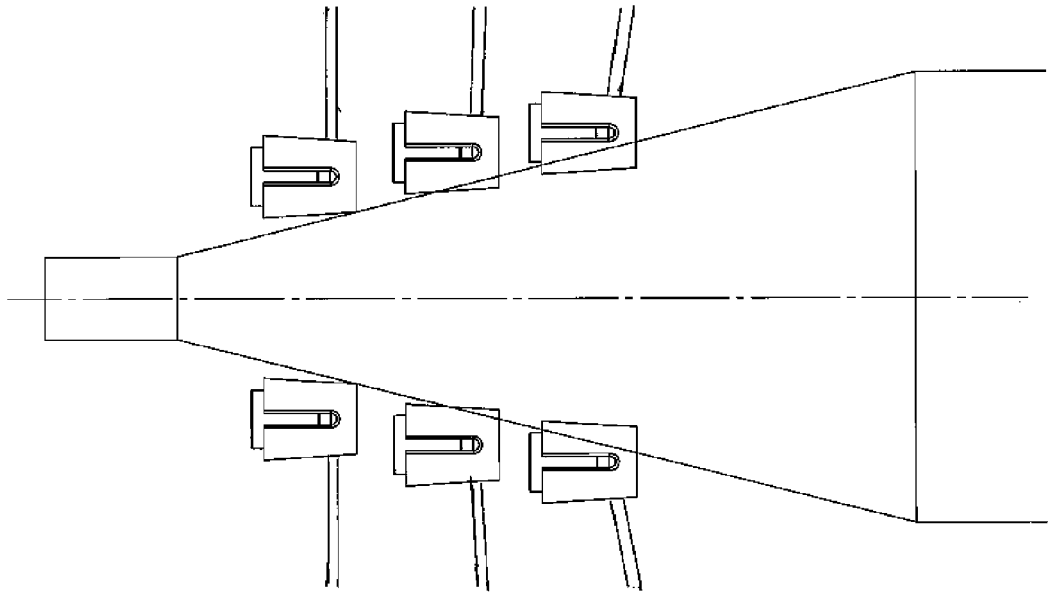

Fig. 10



EUROPEAN SEARCH REPORT

Application Number
EP 19 46 1550

5

10

15

20

25

30

35

40

45

50

55

DOCUMENTS CONSIDERED TO BE RELEVANT			
Category	Citation of document with indication, where appropriate, of relevant passages	Relevant to claim	CLASSIFICATION OF THE APPLICATION (IPC)
A	EP 2 662 657 A2 (FOSTER MILLER INC [US]) 13 November 2013 (2013-11-13) * paragraph [0032]; claim 1; figures 6a,6b *	1	INV. F41H5/02
A	----- US 2010/288114 A1 (SOUKOS KONSTANTINOS N [GR]) 18 November 2010 (2010-11-18) * claim 1; figures 4-7 *	1	
A	----- DE 691 067 C (TRAPEZDRAHT SIEB G M B H) 16 May 1940 (1940-05-16) * claim 2 *	1	
A	----- EP 2 533 006 A2 (PLASAN SASA LTD [IL]) 12 December 2012 (2012-12-12) * paragraph [0040]; claim 1; figures 5-7 *	1	
The present search report has been drawn up for all claims			TECHNICAL FIELDS SEARCHED (IPC)
			F41H
Place of search		Date of completion of the search	Examiner
The Hague		15 January 2020	Beaufumé, Cédric
CATEGORY OF CITED DOCUMENTS			
X : particularly relevant if taken alone Y : particularly relevant if combined with another document of the same category A : technological background O : non-written disclosure P : intermediate document		T : theory or principle underlying the invention E : earlier patent document, but published on, or after the filing date D : document cited in the application L : document cited for other reasons & : member of the same patent family, corresponding document	

1
EPO FORM 1503 03/02 (P04/C01)

ANNEX TO THE EUROPEAN SEARCH REPORT
ON EUROPEAN PATENT APPLICATION NO.

EP 19 46 1550

5 This annex lists the patent family members relating to the patent documents cited in the above-mentioned European search report.
The members are as contained in the European Patent Office EDP file on
The European Patent Office is in no way liable for these particulars which are merely given for the purpose of information.

15-01-2020

Patent document cited in search report	Publication date	Patent family member(s)	Publication date
EP 2662657 A2	13-11-2013	AU 2009271716 A1	21-01-2010
		CA 2721701 A1	21-01-2010
		EP 2265889 A2	29-12-2010
		EP 2662657 A2	13-11-2013
		IL 208683 A	31-12-2014
		IL 228028 A	28-09-2017
		JP 5518842 B2	11-06-2014
		JP 2011518305 A	23-06-2011
		PL 2662657 T3	29-12-2017
		US 2009266227 A1	29-10-2009
		US 2012067199 A1	22-03-2012
		US 2012180639 A1	19-07-2012
		WO 2010008428 A2	21-01-2010
US 2010288114 A1	18-11-2010	AT 500483 T	15-03-2011
		CA 2692757 A1	22-01-2009
		CY 1111620 T1	07-10-2015
		JP 2010533279 A	21-10-2010
		US 2010288114 A1	18-11-2010
		ZA 201000198 B	29-09-2010
DE 691067 C	15-01-2020	NONE	
EP 2533006 A2	12-12-2012	AU 2012203499 A1	20-12-2012
		CA 2779218 A1	06-12-2012
		EP 2533006 A2	12-12-2012
		ES 2693536 T3	12-12-2018
		IL 213397 A	31-05-2015
		IL 213972 A	31-03-2015
		PL 2533006 T3	30-11-2018
		RU 126113 U1	20-03-2013
		TR 201816060 T4	21-11-2018
		US 2014007762 A1	09-01-2014

REFERENCES CITED IN THE DESCRIPTION

This list of references cited by the applicant is for the reader's convenience only. It does not form part of the European patent document. Even though great care has been taken in compiling the references, errors or omissions cannot be excluded and the EPO disclaims all liability in this regard.

Patent documents cited in the description

- WO 2014065924 A [0002]
- US 20100288114 A1 [0003]
- EP 2662657 A [0004]
- EP 2780657 A [0005]
- PL 126568 U [0006]