

(19)



(11)

EP 3 757 984 B1

(12)

EUROPEAN PATENT SPECIFICATION

(45) Date of publication and mention of the grant of the patent:
30.11.2022 Bulletin 2022/48

(51) International Patent Classification (IPC):
G10H 1/057 (2006.01) **G10H 1/053** (2006.01)
G10H 1/34 (2006.01) **G10H 7/02** (2006.01)
G10H 1/18 (2006.01)

(21) Application number: **20180044.8**

(52) Cooperative Patent Classification (CPC):
G10H 1/053; G10H 1/057; G10H 1/342; G10H 1/18; G10H 7/02; G10H 2230/075; G10H 2250/541

(22) Date of filing: **15.06.2020**

(54) ELECTRONIC MUSICAL INSTRUMENT, METHOD AND PROGRAM

ELEKTRONISCHES MUSIKINSTRUMENT, VERFAHREN UND PROGRAMM

INSTRUMENT DE MUSIQUE ÉLECTRONIQUE, PROCÉDÉ ET PROGRAMME

(84) Designated Contracting States:
AL AT BE BG CH CY CZ DE DK EE ES FI FR GB GR HR HU IE IS IT LI LT LU LV MC MK MT NL NO PL PT RO RS SE SI SK SM TR

(72) Inventor: **SATO, Hiroki**
Tokyo, 205-8555 (JP)

(30) Priority: **27.06.2019 JP 2019120368**

(74) Representative: **Plougmann Vingtoft a/s**
Strandvejen 70
2900 Hellerup (DK)

(43) Date of publication of application:
30.12.2020 Bulletin 2020/53

(56) References cited:
US-A- 5 147 970 **US-A1- 2008 245 213**
US-A1- 2009 080 677

(73) Proprietor: **Casio Computer Co., Ltd.**
Tokyo 151-8543 (JP)

EP 3 757 984 B1

Note: Within nine months of the publication of the mention of the grant of the European patent in the European Patent Bulletin, any person may give notice to the European Patent Office of opposition to that patent, in accordance with the Implementing Regulations. Notice of opposition shall not be deemed to have been filed until the opposition fee has been paid. (Art. 99(1) European Patent Convention).

Description

TECHNICAL FIELD

[0001] The present disclosure relates to an electronic musical instrument, a method and a program.

BACKGROUND ART

[0002] In the related art, a variety of technologies for reproducing sounds of musical instruments with strings, including an acoustic piano, a guitar and the like, in an electronic musical instrument are developed. In the musical instruments with strings, not only a usual musical instrument sound but also a sound that is generated as a result of contact of the string with another object is generated. Therefore, also in the electronic musical instruments, it is attempted to reproduce such contact sound.

[0003] For example, JP-A-2011-154394 discloses technology of reproducing a sound of a damper coming into contact with a vibrating string upon key release of an acoustic piano.

[0004] According to the technology disclosed in JP-A-2011-154394, only the same monotonous contact sound is always reproduced.

[0005] US 2009/080677 A1 discloses a stringed instrument and preamplifier combination where the preamplifier simulates the sound of analog tube amplifiers, and contains only solid state active devices. The preamplifier uses a diode branch with the diode biased into its forward active region and as a non-linear resistive element to provide signal-modulated gain on the operational amplifier gain stage. An alternative embodiment supplements the diode branch with series and parallel resistors as additional design optimization parameters. Another alternative embodiment adds symmetrical output clipping diodes to simulate a vacuum tube push-pull output independently of the diode branch.

[0006] US 5 147 970 A discloses an electronic musical instrument for generating musical tones on the basis of characteristics of input waveform signal. A vibration of a string is picked up by a pickup to be converted to an electric signal. A pitch extracting circuit obtains pitch data expressing a pitch or a duration of the string vibration from the electric signal. A musical tone generating circuit generates a musical tone having a corresponding tone pitch in accordance with the pitch data. An envelope extracting circuit extracts an envelope from the electric signal detected by the pickup and supplies a signal expressing the envelope to a multiplier. The extracted envelope signal is multiplied to the musical tone signal by a multiplier after a predetermined timing has been past. In other case, the extracted envelope signal is mixed with a synthesized envelope signal at a desired ratio, thereafter the mixed envelope signal is imparted to the musical tone signal by multiplying processing.

[0007] US 2008/245213 A1 discloses a music sound

generator imitates released key string vibration sounds (RKSV) and cabinet resonances of an acoustic piano. When a key is pressed, waveform is readout from a normal music sound waveform memory 15. The normal sound waveform is inputted into a filter 21, and inputted into a filter 22 through a band-pass filter 33. Output waveform of a cabinet resonance waveform memory 17 is inputted into a filter 23 when the key is pressed. Outputs of the filters are synthesized by an adder 27 through multipliers 24 through 26. When the key is pressed, a cut-off frequency of the filter 22 is sufficiently low and RKSV is not generated. If the damper is not on when key-releasing, the cut-off frequency is returned to normal and RKSV is generated. A level controller 32 attenuates the RKSV and the cabinet resonance for a longer time than the normal music sound.

SUMMARY OF DISCLOSURE

[0008] The invention is as defined by the appended claims.

[0009] According to the present disclosure, it is possible to favorably reproduce a contact sound that is generated when playing the acoustic musical instrument.

BRIEF DESCRIPTION OF DRAWINGS

[0010]

FIG. 1A is a view for illustrating a contact sound that is generated in an acoustic piano;

FIG. 1B is a view for illustrating Comparative Example where a contact sound that is generated in the acoustic piano is not reproduced, and an embodiment of the present disclosure where the contact sound is reproduced;

FIG. 2A is a view for illustrating a contact sound that is generated in a guitar;

FIG. 2B is a view for illustrating Comparative Example where a contact sound that is generated in the guitar is not reproduced, and an embodiment of the present disclosure where the contact sound is reproduced;

FIG. 3 depicts an example of an outer shape of an electronic musical instrument in accordance with an embodiment of the present disclosure;

FIG. 4 is a block diagram depicting a hardware configuration of the electronic musical instrument;

FIG. 5 is a view for illustrating a normal waveform and a difference waveform;

FIG. 6 is a block diagram depicting a schematic configuration of a sound source LSI;

FIG. 7 is a view for illustrating addition processing of the normal waveform and the difference waveform;

FIG. 8A depicts an example of an envelope for generating a piano sound;

FIG. 8B depicts an example of the envelope for gen-

erating the piano sound;
 FIG. 8C depicts an example of the envelope for generating the piano sound;
 FIG. 9A depicts an example of an envelope for generating a guitar sound;
 FIG. 9B depicts an example of the envelope for generating the guitar sound;
 FIG. 9C depicts an example of the envelope for generating the guitar sound;
 FIG. 10 is a flowchart depicting a sequence of processing that is executed by a CPU; and
 FIG. 11 is a subroutine flowchart depicting a sequence of sound source LSI control processing of step S108 in FIG. 10.

DESCRIPTION OF EMBODIMENTS

[0011] Hereinbelow, after describing the principle of the present disclosure, embodiments based on the principle of the present disclosure will be described with reference to the accompanying drawings.

[0012] In the description of the drawings, the same elements are denoted with the same reference signs, and the overlapping descriptions are omitted. Also, for convenience of descriptions, the dimensional ratios in the drawings may be different from the actual ratios due to exaggerated illustrations.

<Principle of Present Disclosure>

[0013] First, in a musical instrument with strings, a cause of a contact sound that is generated as a result of contact of the string with another object, and an output image of a waveform including the contact sound are described.

[0014] FIG. 1A is a view for illustrating a contact sound that is generated in an acoustic piano. FIG. 1B illustrates an output image diagram of a waveform that does not include a contact sound generated in the acoustic piano (Comparative Example), and an output image diagram of a waveform that includes the contact sound (first embodiment).

[0015] In an acoustic piano 100 as shown in FIG. 1A, when a key 110 is released, a damper 120 comes into contact with a string 130, so that vibration of the string 130 is attenuated. Even when felt used for the damper 120 is made of a soft material, the felt applies a larger resistance to the string 130, as compared to the air. Therefore, when the damper 120 comes into contact with the string 130, the vibration of the string 130 is irregularly attenuated, so that a contact sound is generated. While an amplitude of the string 130 is large, the damper 120 is bounced (jumped up) by the string 130 and cannot be thus in contact with the string 130 for a long time. However, as the amplitude of the string 130 becomes smaller over time, a time period for which the damper 120 is in contact with the string 130 becomes longer, and the contact sound is emphasized among sounds being pro-

duced.

[0016] In an electronic musical instrument configured to reproduce sounds of the acoustic piano 100, as shown in an upper drawing of FIG. 1B (Comparative Example), a level of sound, i.e., an amplitude of a waveform upon the key release is controlled so as to change over time, in accordance with an envelope that reproduces an envelope of amplitudes of the string 130 upon the key release. However, in the electronic musical instrument of the related art, the change in contact sound over time as described above is not reproduced. Therefore, in an electronic musical instrument of the present embodiment, as shown in a lower drawing of FIG. 1B (the first embodiment of the present disclosure), a threshold value envelope indicating threshold values of generation of the contact sound is set, and when an amplitude envelope of a waveform exceeds the threshold value envelope, amplitudes of the waveform are restricted, so that the contact sound is generated. Thereby, a distortion sound corresponding to a waveform of which amplitudes are restricted is generated as a sound that simulates the contact sound. For example, amplitudes of a waveform with respect to a sound upon the key release of the acoustic piano 100 are controlled so as to be largely restricted over time. Also, the distortion sound as the contact sound is controlled so as to be further emphasized as a time period k1, a time period k2, and a time period k3 progress, as shown in the lower drawing of FIG. 1B, for example (a difference value between a broken line value of the broken line indicative of the threshold value envelope and a solid line value of the solid line indicative of an amplitude envelope gradually increases as the time period k1, the time period k2, and the time period k3 progress, so that the amplitudes of the waveform are largely restricted over time and the contact sound that is the distortion sound is further emphasized over time). Therefore, it is possible to favorably reproduce the contact sound of the damper 120 and the string 130, which is generated upon the key release in the acoustic piano 100.

[0017] FIG. 2A is a view for illustrating a contact sound that is generated in a guitar. FIG. 2B is an output image diagram of a waveform that does not include a contact sound generated in the guitar (Comparative Example), and an output image diagram of a waveform that includes the contact sound (second embodiment).

[0018] Also in plucked string instruments such as a guitar 200 as shown in FIG. 2A, when a string release where a player's finger F releases from a string 210 is performed, a contact sound is generated. More specifically, while the finger F presses the string 210, the contact sound is not generated because the string 210 vibrates about a fret 220 as a support point. However, when the finger F starts to move away from the fret 220, the support point of the string 210 moves from the fret 220 to the finger F, so that the string 210 vibrates about the finger F as a support point. When the string 210 comes into contact with the fret 220 or the like, the contact sound is generated. For this reason, in the guitar 200, the contact

sound starts to be heard immediately after the string releases, unlike the acoustic piano 100. Then, as the amplitude of the string 210 becomes smaller over time or the finger F moves away from the fret 220, the contact sound becomes difficult to be heard.

[0019] In the electronic musical instrument configured to reproduce sounds of the guitar 200, as shown in an upper drawing of FIG. 2B, a level of sound, i.e., an amplitude of a waveform upon the key release is controlled so as to change over time, in accordance with an envelope that reproduces an envelope of amplitudes of the string 210 upon the key release. More specifically, the amplitude of the waveform is controlled so as to increase over time during a time period k4 immediately after the key release of the electronic musical instrument, i.e., immediately after the key release of the guitar 200, and to attenuate over time during time periods k5 and k6 thereafter, for example. The threshold value envelope is set as shown in a lower drawing of FIG. 2B, for example. The distortion sound as the contact sound is controlled so that it is emphasized over time during the time period k4 (because the difference value between the broken line value of the broken line and the solid line value of the solid line becomes gradually larger), is attenuated over time during the time period k5 (because the difference value between the broken line value of the broken line and the solid line value of the solid line becomes gradually smaller), and is not heard during the time period k6 (because the solid line value has not reached the broken line value). Thereby, it is possible to favorably reproduce the contact sound that is generated when the string 210 comes into contact with the fret or the like upon the key release in the guitar 200.

[0020] In the below, a configuration, processing and the like of the electronic musical instrument configured to reproduce the contact sounds as described above are described with reference to the drawings.

[Embodiment of Disclosure]

(Configuration)

[0021] FIG. 3 depicts an example of an outer shape of an electronic musical instrument in accordance with an embodiment of the present disclosure. FIG. 4 is a block diagram depicting a hardware configuration of the electronic musical instrument. FIG. 5 is a view for illustrating a normal waveform and a difference waveform.

[0022] As shown in FIGS. 3 and 4, an electronic musical instrument 300 includes a CPU (Central Processing Unit) 310, a RAM (Random Access Memory) 320, a ROM (Read Only Memory) 330, a switch panel 340, an LCD (liquid crystal monitor) 350, a keyboard 360, a sound source LSI (large-scale integration) 370, a D/A converter 380, an amplifier 385 and a timer counter 390. The CPU 310, the RAM 320, the ROM 330 and the sound source LSI 370 are each connected to a bus 395. Also, the switch panel 340, the LCD 350 and the keyboard 360 are each

connected to the bus 395 via each of an I/O interface 345, an LCD controller 355 and a key scanner 365.

[0023] The CPU 310 as a processor is configured to control the respective constituent elements and to execute a variety of calculation processing, in accordance with programs. The RAM 320 is configured to temporarily store programs, data and the like, as a work area.

[0024] The ROM 330 as a memory has a program area and a data area, and stores a variety of programs, data and the like in advance. The ROM 330 is configured to store a plurality of pieces of waveform data corresponding to multiple musical instrument sounds, as a waveform memory, for example.

[0025] More specifically, the ROM 330 is configured to store first waveform data of a normal waveform and second waveform data (positive/negative inversion data) of a difference waveform as shown in FIG. 5, with respect to a sound of a musical instrument that generates a contact sound of a string. The normal waveform is a waveform corresponding to a usual musical instrument sound having intervals and not including a contact sound of a string. On the other hand, the difference waveform is a waveform in which a portion exceeding a certain clipping level is cut out from the normal waveform and is made into an opposite phase, i.e., a sign (positive/negative) of the portion is inverted. The difference waveform is generated in advance, based on a normal waveform and a clipping level set in accordance with an envelope of the normal waveform. The clipping level may be set to a level obtained by multiplying a fixed ratio (for example, 90%) by a level indicated by the envelope of the normal waveform. However, the method of setting the clipping level is not limited to the above example, and the clipping level may be varied over time, in accordance with a playing method, and the like. In the meantime, for a musical instrument that does not generate a contact sound of a string, the ROM 330 stores data of a normal waveform, and does not store data of a difference waveform.

[0026] Returning to FIG. 4, the switch panel 340 includes a plurality of switches 341, and is configured to receive a user operation of pressing each of the plurality of switches 341. For example, the switch panel 340 includes the plurality of switches 341 corresponding to multiple musical instrument sounds, and receives a user operation of selecting a certain musical instrument sound from the multiple musical instrument sounds. The I/O interface 345 is configured to monitor each of the plurality of switches 341 of the switch panel 340, and, when it is detected that each of the plurality of switches 341 is pressed, notifies the detection to the CPU 310.

[0027] The LCD 350 is configured to display a variety of information. The LCD controller 355 is an IC (integrated circuit) configured to control the LCD 350.

[0028] The keyboard 360 has a plurality of keys 361 as operation elements, and is configured to receive user operations of pressing and releasing the keys, as a user operation. Each of the plurality of keys 361 is configured to operate at one end of a leaf spring or the like, as a

support point, and may include a plurality of switches (contact points) that is sequentially turned on or off by the key pressing or the key release.

[0029] The key scanner 365 is configured to monitor each of the plurality of keys 361 of the keyboard 360, and to detect whether each of the plurality of keys 361 is pressed or released. When the key pressing is detected, the key scanner 365 detects and notifies, to the CPU 310, a key number (note number) of the pressed key 361, and a velocity upon the key pressing corresponding to a key pressing speed. Also, when the key release is detected, the key scanner 365 detects and notifies, to the CPU 310, a key number of the released key 361, and a velocity upon the key release corresponding to a key release speed. The key scanner 365 may detect the velocity upon the key pressing or upon the key release by measuring a difference between times at which at least two switches of each of the plurality of keys 361 are detected to be on or off.

[0030] The sound source LSI 370 as a processor adopts a well-known waveform memory reading method, and is configured to read out and process waveform data corresponding to a musical instrument sound selected by the user from the ROM 330, and to output the same to the D/A converter 380. The sound source LSI 370 will be described later in detail with reference to FIG. 5.

[0031] The D/A converter 380 is configured to convert digital waveform data output from the sound source LSI 370 into analog waveform signals, and to output the same to the amplifier 385. The amplifier 385 is configured to amplify the analog waveform signals output from the D/A converter 380, and to output the same to a speaker, an output terminal or the like (not shown).

[0032] The timer counter 390 includes a counter configured to increment a value every 1 μ sec, for example, and is configured to measure time.

[0033] In the meantime, the electronic musical instrument 300 may include a constituent element, in addition to the above-described constituent elements, and may not include some of the above-described constituent elements.

[0034] Subsequently, the sound source LSI 370 is described in detail. FIG. 6 is a block diagram depicting a schematic configuration of the sound source LSI. FIG. 7 is a view for illustrating addition processing of the normal waveform and the difference waveform.

[0035] As shown in FIG. 6, the sound source LSI 370 includes a plurality of generator sections 371 (for example, corresponding to 256 channels), and a generator mixer 372 configured to mix waveform data that is output from each of the generator sections 371. Each of the generator sections 371 includes a normal channel (also referred to as a normal system or a first system) 373 including a normal waveform generator (first waveform generator) 3731, a normal waveform filter 3732, a normal waveform amplifier (first waveform amplifier) 3733 and the like, a difference channel (also referred to as a difference system or a second system) 374 including a dif-

ference waveform generator (second waveform generator) 3741, a difference waveform filter 3742, a difference waveform amplifier (second waveform amplifier) 3743 and the like, and a section mixer 375 configured to mix (add) waveform data (also referred to as "output data") in each channel. Also, each of the generator sections 371 further includes a normal waveform filter envelope generator 3734, a normal waveform amplifier envelope generator 3735, an envelope detector 3736, a difference waveform filter envelope generator 3744, an envelope comparison unit 3745 and a threshold value envelope generator 3746 for controlling each of the constituent elements. Meanwhile, in the below, as shown in FIG. 6, the envelope generator is also denoted as "EG".

[0036] The normal waveform generator 3731 is configured to read out, from the ROM 330, normal waveform data corresponding to a musical instrument sound selected by the user at a reading speed corresponding to the key number of the pressed key 361, and to generate normal waveform data corresponding to the key number. The normal waveform filter 3732 is configured to control a quality of sound corresponding to the normal waveform data, in accordance with a filter envelope generated by the normal waveform filter EG 3734 and indicating a temporal change in a cutoff frequency of a filter (for example, a low-pass filter). The normal waveform amplifier 3733 is configured to control a level of sound corresponding to the normal waveform data, i.e., an amplitude of the normal waveform, in accordance with an amplifier envelope generated by the normal waveform amplifier EG 3735 and indicating a temporal change in a volume of sound (level). That is, the normal waveform data is input to the normal waveform generator 3731, and is output from the normal waveform amplifier 3733. The envelope detector 3736 includes an absolute value circuit (full wave rectification circuit), a low-pass filter and the like, and is configured to detect an amplitude envelope of a waveform indicated by the normal waveform data output from the normal waveform amplifier 3733.

[0037] The difference waveform generator 3741 is configured to read out, from the ROM 330, difference waveform data corresponding to a musical instrument sound selected by the user at a reading speed corresponding to the key number of the pressed key 361, and to generate difference waveform data corresponding to the key number. The difference waveform generator 3741 is configured to read out the difference waveform data at a timing that is synchronous with the reading timing of the normal waveform data. The difference waveform filter 3742 is configured to control a quality of sound corresponding to the difference waveform data, in accordance with a filter envelope generated by the difference waveform filter EG 3744. The difference waveform amplifier 3743 is configured to control a level of sound corresponding to the difference waveform data, in accordance with an amplifier envelope output by the envelope comparison unit 3745. In the present embodiment, the envelope comparison unit 3745 is configured to out-

put an amplifier envelope (multiplication coefficient) of the difference waveform, based on a comparison result of the amplitude envelope of the normal waveform detected by the envelope detector 3736 and a threshold value envelope generated by the threshold EG 3746. Therefore, it can be said that an output value of the difference waveform amplifier 3743 is a value in which a shape of the difference waveform is adjusted based on the difference between the envelopes. In other words, it can be said that a waveform of output values when the difference of the comparison result is a second difference larger than a first difference is adjusted so that it is larger than a waveform when the difference of the comparison result is the first difference.

[0038] More specifically, the threshold EG 3746 is configured to generate a threshold value envelope indicating a temporal change in threshold value that is determined in accordance with a musical instrument sound selected by the user, as shown in FIGS. 1B and 2B. The envelope comparison unit 3745 is configured to output an amplifier envelope (multiplication coefficient) indicating a temporal change in level (difference) that is obtained by subtracting a level of the threshold value envelope generated by the threshold EG 3746 from a level of the amplitude envelope of the normal waveform detected by the envelope detector 3736. Therefore, as the level obtained by the subtraction is larger, the envelope comparison unit 3745 outputs an amplifier envelope having a larger level. Thereby, as shown in FIGS. 1B and 2B, as an amplitude of a waveform corresponding to the amplitude envelope largely exceeds the threshold value envelope, the amplitude is largely restricted. In the meantime, when a value of the level obtained by the subtraction is a negative value, the envelope comparison unit 3745 may output an amplifier envelope of which a value of a level is zero.

[0039] If the comparison result by the envelope comparison unit 3745 is the same, the multiplication coefficient becomes zero, so that the difference waveform is not output from the difference waveform amplifier 3743. The normal waveform output from the normal waveform amplifier 3733 is output from the section mixer 375, as it is.

[0040] As the comparison result becomes larger, the multiplication coefficient approximates to 1 from 0, and a shape of the difference waveform output from the difference waveform amplifier 3743 approximates to a shape of the stored difference waveform. A waveform having such a shape that a waveform of the portions of the normal waveform exceeding the clipping level is slightly changed so as to approximate to the clipping level as the multiplication coefficient approximates to 1 from 0 is output from the section mixer 375.

[0041] When the multiplication coefficient is 1.0, a shape of the difference waveform that is output from the difference waveform amplifier 3743 becomes the same as the shape of the stored difference waveform, and a waveform having such a shape that the portions of the normal waveform exceeding the clipping level are clipped

is output from the section mixer 375.

[0042] As a result, as shown in the embodiment of the present disclosure of FIG. 2B, an amplitude of a waveform at a boundary between time periods k4 and k5 in which the difference value between the envelope and the clipping level is large is located on a broken line-side between the solid line value and the broken line value. On the other hand, an amplitude of a waveform at a boundary between time periods k5 and k6 in which the difference value between the envelope and the clipping level is small is located on the solid line-side between the solid line value and the broken line value.

[0043] In the meantime, the multiplication coefficient may also be a value larger than 1.0.

[0044] In a case where the present disclosure is applied and a half of the 256 waveform generators, for example, is used for oscillation of the difference waveform, the number of simultaneous tones may be restricted to 128 from 256. However, according to the present disclosure, it is possible to favorably express the contact sound by the simple processing of using the existing waveform generators.

[0045] Each of the EGs 3734, 3735, 3744 and 3746 as described above is configured to generate each envelope as shown in FIGS. 8A and 8B, based on parameters relating to each envelope and supplied from the CPU 310, upon the key pressing and upon the key release. The parameters include a parameter relating to target levels L0 to L4, a parameter relating to rates R1 to R4 for reaching the target levels, and the like. When the value of the amplifier envelope generated by the normal waveform amplifier EG 3735 becomes zero and an operation of the normal waveform amplifier 3733 is thus stopped, an operation of the normal waveform generator 3731 is also stopped. Also, when the value of the amplifier envelope output by the envelope comparison unit 3745 becomes zero and an operation of the difference waveform amplifier 3743 is thus stopped, an operation of the difference waveform generator 3741 is also stopped.

[0046] In the meantime, each of the EGs 3734, 3735, 3744 and 3746 may be supplied with a parameter corresponding to a velocity from the CPU 310 or may generate each envelope corresponding to the velocity. For example, each of the EGs 3734, 3735, 3744 and 3746 may be supplied, from the CPU 310, with parameters including a release rate R4 of which gradient is set gentler as a value of the velocity is smaller, i.e., a key release speed is lower.

[0047] The section mixer 375 is configured to mix a normal waveform indicated by the normal waveform data output from the normal waveform amplifier 3733 and a difference waveform indicated by the difference waveform data output from the difference waveform amplifier 3743. The section mixer 375 outputs data (addition data) of a waveform (added waveform) obtained by adding the normal waveform and the difference waveform, for example, as shown in FIG. 7. Thereby, the section mixer 375 can output the data of the added waveform corre-

sponding to the distortion sound as a sound that simulates the contact sound. More specifically, the section mixer 375 is configured to output, as waveform data reproducing a virtual clipping, data of the added waveform obtained by adding portions of the normal waveform and a difference waveform corresponding to portions of the normal waveform exceeding a certain clipping level.

[0048] The amplitudes of the normal waveform and the difference waveform are respectively controlled, in accordance with the amplifier envelope generated by the normal waveform amplifier EG 3735 and the amplifier envelope output by the envelope comparison unit 3745, as described above. Therefore, an addition ratio of the normal waveform and the difference waveform in the section mixer 375 is also controlled in accordance with the envelopes, and the addition ratio is controlled, so that data of the added waveform including various clipping shapes is output, as shown in FIG. 7. For example, when the addition ratio is 1:1, data of the added waveform in which the amplitude is favorably restricted in the clipping level is output. Also, when the addition ratio is smaller than 1:1 (namely, the addition ratio of the difference waveform to the normal waveform is smaller than 1), data of the added waveform in which a degree of distortion is smaller is output. The added waveform may be a waveform corresponding to a modest contact sound such as a sound that is generated when the soft damper 120 comes into contact with the string 130 in the acoustic piano 100 as shown in FIG. 1A. Also, when the addition ratio is larger than 1:1 (namely, the addition ratio of the difference waveform to the normal waveform is larger than 1), data of the added waveform in which a degree of distortion is larger is output. The added waveform may be a waveform corresponding to a contact sound in which higher harmonics are emphasized, such as a sound that is generated when the string 210 comes into contact with the rigid metal fret 220 in the guitar 200 as shown in FIG. 2A.

[0049] Also, the addition ratio of the normal waveform and the difference waveform is controlled in the section mixer 375, instead of the threshold value envelope or in addition to the threshold value envelope. For example, the operation of the threshold EG 3746 may be stopped, and an amplifier envelope that is similar to the amplitude envelope of the normal waveform detected by the envelope detector 3736 may be output by the envelope comparison unit 3745. In this case, the ratio of the normal waveform and the difference waveform that are input to the section mixer 375 is controlled to a value close to 1:1. Then, in the section mixer 375, the addition ratio of the normal waveform data and the difference waveform data may be adjusted to a setting value of the addition ratio supplied from the CPU 310. Thereby, the addition ratio can be controlled by the simpler method than a method of individually controlling each of the EGs 3735 and 3746 and the like. Alternatively, in the section mixer 375, a rough addition ratio of the normal waveform and the difference waveform may be set as a fixed ratio, and a slight

variation in the addition ratio over time may be reproduced by each of the EGs 3735 and 3746 and the like. Also, the section mixer 375 may be supplied, from the CPU 310, with a setting value of the addition ratio corresponding to a velocity, and may adjust the addition ratio of the normal waveform and the difference waveform to the setting value of the addition ratio corresponding to a velocity.

[0050] Also, the sound source LSI 370 may be configured to implement functions, in addition to the above-described functions, and may also be configured not to implement some of the above-described functions. For example, each of the waveform generators 3731 and 3741 may be configured to execute loop processing of repeatedly reading out each waveform data from the ROM 330, thereby generating each waveform data corresponding to a sustained sound. Also, the generator mixer 372 may be supplied, from the CPU 310, with a setting value of a level corresponding to a velocity or may adjust a value of a level of sound corresponding to each waveform data output from each generator section 371 to the setting value of a level corresponding to a velocity.

(Examples of Envelope)

[0051] Subsequently, examples of the envelope that is generated by each of the EGs 3734, 3735, 3744 and 3746 are described. FIGS. 8A to 8C depict examples of an envelope that is generated for an acoustic piano sound. FIGS. 9A to 9C depict examples of an envelope that is generated for a guitar sound.

[0052] As described above, in the acoustic piano 100 as shown in FIG. 1A, when the key release is performed on the key 110, a sound of the damper 120 coming into contact with the string 130 is generated, and a ratio of the contact sound in the sound being produced increases over time. In order to favorably reproduce the phenomenon, the normal waveform filter EG 3734 and the difference waveform filter EG 3744 generate a filter envelope as shown in FIG. 8A, the normal waveform amplifier EG 3735 generates an amplifier envelope as shown in FIG. 8B, and the threshold value EG 3746 generates a threshold value envelope as shown in FIG. 8C. In the example of FIG. 8C, a value of the threshold value envelope upon the key pressing is set to 1.0 that is the maximum value, so that the contact sound is not generated upon the key pressing. Also, a value of the threshold value envelope upon the key release is set smaller over time, so that the contact sound can be easily heard over time. In the meantime, as described above, in addition to each envelope as shown in FIGS. 8A to 8C, the addition ratio of the normal waveform and the difference waveform may be controlled in the section mixer 375, and the addition ratio of the normal waveform and the difference waveform in the section mixer 375 may be set to about 1:0.6.

[0053] Also, in the guitar 200 as shown in FIG. 2A, when the release is performed on the string 210, a sound of the string 210 coming into contact with the fret 220 or

the like is generated, and the contact sound is difficult to be heard over time. In order to reproduce the phenomenon, the normal waveform filter EG 3734 and the difference waveform filter EG 3744 generate a filter envelope as shown in FIG. 9A, the normal waveform amplifier EG 3735 generates an amplifier envelope as shown in FIG. 9B, and the threshold value EG 3746 generates a threshold value envelope as shown in FIG. 9C. In the example of FIG. 9C, a value of the threshold value envelope upon the key pressing is set smaller than a value of the normal waveform amplifier envelope during a certain time period immediately after the key is pressed, so that the contact sound is generated upon the key release and during a certain time period when pressing the key. Also, a value of the threshold value envelope upon the key release is set to the minimum value immediately after the key release, and increases toward 1.0 that is the maximum value. Thereby, the contact sound is difficult to be heard over time. In the meantime, as described above, in addition to each envelope as shown in FIGS. 9A to 9C, the addition ratio of the normal waveform and the difference waveform may be controlled in the section mixer 375, and the addition ratio of the normal waveform and the difference waveform in the section mixer 375 may be set to about 1:1.5.

(Processing)

[0054] Subsequently, processing that is executed by the CPU 310 is described in detail. FIG. 10 is a flowchart depicting a sequence of processing that is executed by the CPU. FIG. 11 is a subroutine flowchart depicting a sequence of sound source LSI control processing of step S108 in FIG. 10. Algorithms shown in each flowchart are stored as programs in the ROM 330 or the like, and are executed by the CPU 310.

[0055] As shown in FIG. 10, when a power supply becomes on, the CPU 310 first executes initialization processing on each constituent element of the electronic musical instrument 300 (step S101). Then, the CPU 310 executes user interface processing (UI processing) of displaying a variety of information on the LCD 350 or receiving a user operation via the switch panel 340 (step S102). For example, the CPU 310 receives a user operation of selecting a certain musical instrument sound from the multiple musical instrument sounds, via the switch panel 340.

[0056] Subsequently, the CPU 310 determines whether the user has performed the key pressing (step S103). When it is determined that the key pressing has been performed (step S103: YES), the CPU 310 executes key pressing processing (also referred to as "sound producing processing" or "note-on processing") (step S104). The key pressing processing includes processing of acquiring a key number and a velocity of the key 361 on which the key pressing has been performed, processing of assigning the generator section 371, and the like, for example. Also, the key pressing processing includes con-

trol processing for causing the sound source LSI 370 to execute initialization and operation start of each of the waveform generators 3731 and 3741 in the assigned generator section 371, readout of the waveform data in each of the waveform generators 3731 and 3741 of which operations have started, initialization of each of the EGs 3734, 3735, 3744 and 3746, and the like. In the meantime, the operation of each of the EGs 3734, 3735, 3744 and 3746 is automatically started in EG steady processing of step S107, which will be described later. On the other hand, when it is determined that the key pressing has not been performed (step S103: NO), the CPU 310 proceeds to processing of step S105.

[0057] Subsequently, the CPU 310 determines whether the user has performed the key release (step S105). When it is determined that the key release has been performed (step S105: YES), the CPU 310 executes key release processing (also referred to as "silencing processing", "sound muffling processing" or "note-off processing") (step S106). The key release processing includes processing of acquiring a key number and a velocity of the key 361 on which the key release has been performed, control processing of each of the EGs 3734, 3735, 3744 and 3746, and the like, for example. That is, the CPU 310 executes, as the key release processing, processing of shifting each of the EGs 3734, 3735, 3744 and 3746 to a release state, for example. On the other hand, when it is determined that the key release has not been performed (step S105: NO), the CPU 310 proceeds to processing of step S107.

[0058] Subsequently, the CPU 310 executes EG steady processing (step S107). More specifically, the CPU 310 supplies parameters corresponding to the selected musical instrument sound and the current state to each of the EGs 3734, 3735, 3744 and 3746, thereby executing processing of generating envelopes. Then, the CPU 310 executes sound source LSI control processing (step S108). The sound source LSI control processing will be described later in detail with reference to FIG. 11.

[0059] Subsequently, the CPU 310 determines whether a value counted by the timer counter 390 is equal to or greater than 1000 μ sec, i.e., 1ms (step S109). When it is determined that the counted value is not equal to or greater than 1000 μ sec, i.e., is less than 1000 μ sec (step S109: NO), the CPU 310 stands by until the counted value becomes equal to or greater than 1000 μ sec. On the other hand, when it is determined that the counted value is equal to or greater than 1000 μ sec (step S109: YES), the CPU 310 subtracts 1000 μ sec from the value counted by the timer counter 390 (step S110), and returns to the processing of step S102. That is, the CPU 310 executes the processing of step S109 and S110 so as to execute the processing from step S102 to S108 every 1000 μ sec on average.

[0060] Subsequently, the sound source LSI control processing of step S108 is described in detail. The CPU 310 controls the sound source LSI 370 to execute processing from step S201 to S206 shown in FIG. 11.

[0061] More specifically, as shown in FIG. 11, in the sound source LSI 370, the filter envelope generated by the difference waveform filter EG 3744 is set in the difference waveform filter 3742 (step S201). Also, the amplifier envelope output by the envelope comparison unit 3745 is set in the difference waveform amplifier 3743 (step S202). Also, the filter envelope generated by the normal waveform filter EG 3734 is set in the normal waveform filter 3732 (step S203), and the amplifier envelope generated by the normal waveform amplifier EG 3735 is set in the normal waveform amplifier 3733 (step S204).

[0062] Then, it is determined whether both a value of the amplifier envelope generated by the normal waveform amplifier EG 3735 and a value of the amplifier envelope output by the envelope comparison unit 3745 have reached zero and the operations of both the normal waveform amplifier 3733 and the difference waveform amplifier 3743 have stopped (step S205).

[0063] When it is determined that the operations of both the amplifiers 3733 and 3743 have stopped (step S205: YES), the operations of the normal waveform generator 3731 and the difference waveform generator 3741 are also stopped (step S206), and the sound source LSI control processing is over. On the other hand, when it is determined that the operations of both the amplifiers 3733 and 3743 have not stopped (step S205: NO), the sound source LSI control processing is over.

[0064] The present embodiment achieves following effects.

[0065] The electronic musical instrument 300 outputs the data of the added waveform obtained by adding the normal waveform and the difference waveform corresponding to the portions of the normal waveform exceeding a certain clipping level. Thereby, the electronic musical instrument 300 can reproduce the contact sound of the string that is generated in the musical instrument with strings and changes over time and in accordance with a playing method and the like simply by executing the addition processing that is relatively simple signal processing.

[0066] Also, in the electronic musical instrument 300, the difference waveform is a waveform in which a sign of the portions of the normal waveform exceeding a certain clipping level is inverted. Thereby, the electronic musical instrument 300 can add the normal waveform and the difference waveform corresponding to the portions of the normal waveform exceeding a certain clipping level and can output the data of the added waveform in which a virtual clipping is reproduced.

[0067] Also, in the electronic musical instrument 300, the output value of the difference waveform amplifier 3743 is adjusted, based on the difference between the amplitude envelope of the normal waveform detected by the envelope detector 3736 and the threshold value envelope generated by the threshold EG 3746. Thereby, the electronic musical instrument 300 can favorably reproduce the contact sound that changes in accordance with movement of actual strings in a musical instrument

with strings.

[0068] Also, in the electronic musical instrument 300, the threshold value indicated by the threshold value envelope is determined, in accordance with the musical instrument sound selected by the user. Thereby, the electronic musical instrument 300 can favorably reproduce the contact sound that is different for each musical instrument.

[0069] Also, in the electronic musical instrument 300, the normal waveform and the difference waveform are added with a certain ratio. Thereby, the electronic musical instrument 300 can output the data of the added waveform including various clipping shapes.

[0070] Also, in the electronic musical instrument 300, the addition ratio of the normal waveform and the difference waveform when the guitar sound is selected from the multiple musical instrument sounds is set larger than the addition ratio when the acoustic piano sound is selected. Thereby, the electronic musical instrument 300 can favorably reproduce the contact sound of the soft damper 120 coming into contact with the string 130 in the acoustic piano 100 and the contact sound of the string 210 coming into contact with the rigid metal fret 220 in the guitar 200.

[0071] In the meantime, the present disclosure is not limited to the above-described embodiment, and can be diversely changed and improved within the claims.

[0072] For example, in the above-described embodiment, the difference waveform data is generated in advance and is stored in the ROM 330. However, the difference waveform data may not be stored in the ROM 330. In this case, when the normal waveform data is read out from the ROM 330, the difference waveform data may be generated based on the normal waveform data.

[0073] Also, in the above-described embodiment, the clipping level is set in the positive region of the normal waveform. However, the clipping level may also be set in the negative region of the normal waveform. In this case, the difference waveform is generated as a waveform corresponding to portions in the negative region of the normal waveform exceeding a certain clipping level. Also, the clipping level may be set for both the positive and negative regions of the normal waveform.

[0074] Also, in the above-described embodiment, the parameter, the setting value and the like corresponding to the velocity are supplied from the CPU 310 to the sound source LSI 370. However, a parameter, a setting value and the like corresponding to an element other than the velocity may be supplied to the sound source LSI 370. As the element other than the velocity, after-touch that can be detected by a pressure sensor or the like may be exemplified.

[0075] Also, in the above-described embodiment, the processing shown in FIG. 10 is executed by the CPU 310. However, at least some of the processing shown in FIG. 10 may be executed by the sound source LSI 370.

[0076] Also, in the above-described embodiment, the contact sounds that are generated in the acoustic piano

100 and the guitar 200 are reproduced in the electronic musical instrument 300. However, contact sounds that are generated in other musical instruments with strings may also be reproduced. As the other musical instruments, folk musical instruments such as sitar having a contact plate (bridge), a fretless bass, and the like may be exemplified. In the folk musical instruments such as sitar, even when vibration of the string is small to some extent, a long and stable contact sound is generated. In order to reproduce such contact sound, the electronic musical instrument 300 may control so that a value of a level obtained by subtracting a level of the threshold value envelope from a level of the amplitude envelope is a positive value for a long time.

[0077] Also, in the above-described embodiment, the contact sounds that are generated in the musical instruments with strings are reproduced in the electronic musical instrument 300. However, the contact sounds may be reproduced in other instruments. As the other instruments, a PC and the like that are used for music production may be exemplified.

Reference Signs List

[0078]

- 300: electronic musical instrument
- 310: CPU
- 320: RAM
- 330: ROM
- 340: switch panel
- 350: LCD
- 360: keyboard
- 370: sound source LSI
- 371: generator section
- 372 generator mixer
- 373: normal channel
- 3731: normal waveform generator
- 3732: normal waveform filter
- 3733: normal waveform amplifier
- 374: difference channel
- 3741: difference waveform generator
- 3742: difference waveform filter
- 3743: difference waveform amplifier
- 375: section mixer
- 380: D/A converter
- 385: amplifier
- 390: timer counter

Claims

1. An electronic musical instrument comprising:

a memory that stores first waveform data and second waveform data, wherein the second waveform data is an opposite phase of waveform data corresponding to a portion of the first

waveform data exceeding a certain clipping level;
 a first system (373) that includes at least a first wave generator (3731);
 a second system (374) that includes at least a second wave generator (3741);
 means for inputting, based on a user operation on at least one operation element (361), the first waveform data to the first wave generator (3731) of the first system and the second waveform data to a second wave generator (3741) of the second system;
 means for generating addition data (375) by adding, according to an addition ratio, the first output data output from the first system (373) in response to the input of the first waveform data and the second output data output from the second system (374) in response to the input of the second waveform data; and
 means for controlling the addition ratio, in the means for generating addition data (375), such that the higher the addition ratio of the second output data to the first output data becomes, the greater a degree of distortion of the addition data becomes.

2. The electronic musical instrument according to Claim 1, wherein

the first system includes the first wave generator (3731), a normal waveform filter (3732), a first waveform amplifier (3733) configured to output the first output data, and
 the second system includes the second wave generator (3741), a difference waveform filter (3742), a second waveform amplifier (3743) configured to output the second output data.

3. The electronic musical instrument according to Claim 2, wherein a degree of distortion of the addition data is greater when the addition ratio of the second output data (374) to the first output data (373) is a value larger than 1, and is smaller when the addition ratio is a value smaller than 1.

4. The electronic musical instrument according to Claim 2 or 3, further comprising:

means for detecting (3736) an envelope of the first output data (373) output by the first waveform amplifier (3733);
 means for generating (3746) an envelope corresponding to a set threshold value; and
 means for adjusting an output value of the second output data (374) output by the second waveform amplifier (3743), based on a difference between the detected envelope of the first output data (373) and the envelope correspond-

- ing to the set threshold value.
5. The electronic musical instrument according to Claim 4, wherein a waveform of output values of the second output data (374) when the difference is a first difference is smaller than a waveform of output values of the second output data (374) when the difference is a second difference greater than the first difference.
6. The electronic musical instrument according to Claim 4 or 5, wherein the set threshold value is determined depending on a musical instrument which is selected based on a user operation from a plurality of musical instruments.
7. The electronic musical instrument according to Claim 6, wherein a waveform of the second output data that is added when a guitar is selected from the plurality of musical instruments is greater than a waveform of the second output data that is added when a piano is selected from the plurality of musical instruments.
8. A method comprising:
- storing first waveform data and second waveform data in a memory, wherein the second waveform data is an opposite phase of waveform data corresponding to a portion of the first waveform data exceeding a certain clipping level;
- inputting, based on a user operation on at least one operation element (361), the first waveform data to a first wave generator (3731) of a first system (373) and the second waveform data to a second wave generator (3741) of a second system (374),
- generating addition data by adding, according to an addition ratio, the first output data output from the first system (373) in response to the input of the first waveform data and the second output data output from the second system (374) in response to the input of the second waveform data; and
- controlling the addition ratio such that the higher the addition ratio of the second output data to the first output data becomes, the greater a degree of distortion of the addition data becomes.
9. The method according to Claim 8, wherein a degree of distortion of the addition data is greater when the addition ratio of the second output data (374) to the first output data (373) is a value larger than 1, and is smaller when the addition ratio is a value smaller than 1.
10. The method according to Claim 9, further comprising:
- detecting (3736) an envelope of the first output data (373) output by the first waveform amplifier (3733);
- generating (3746) an envelope corresponding to a set threshold value; and
- adjusting an output value of the second output data (374) output by the second waveform amplifier (3743), based on a difference between the detected envelope of the first output data (373) and the envelope corresponding to the set threshold value.
11. The method according to Claim 10, wherein a waveform of output values of the second output data (374) when the difference is a first difference is smaller than a waveform of output values of the second output data (374) when the difference is a second difference greater than the first difference.
12. The method according to Claim 10 or 11, wherein the set threshold value is determined depending on a musical instrument which is selected based on a user operation from a plurality of musical instruments.
13. The method according to Claim 12, wherein a waveform of the second output data that is added when a guitar is selected from the plurality of musical instruments is greater than a waveform of the second output data that is added when a piano is selected from the plurality of musical instruments.
14. A program for causing a computer to execute a process, the process comprising:
- storing first waveform data and second waveform data in a memory, wherein the second waveform data is an opposite phase of waveform data corresponding to a portion of the first waveform data exceeding a certain clipping level;
- inputting, based on a user operation on at least one operation element (361), the first waveform data to a first wave generator (3731) of a first system (373) and the second waveform data to a second wave generator (3741) of a second system (374),
- generating addition data by adding, according to an addition ratio, the first output data output from the first system (373) in response to the input of the first waveform data and the second output data output from the second system (374) in response to the input of the second waveform data; and
- controlling the addition ratio such that the higher the addition ratio of the second output data to

the first output data becomes, the greater a degree of distortion of the addition data becomes.

Patentansprüche

1. Elektronisches Musikinstrument, umfassend:

einen Speicher, der erste Wellenformdaten und zweite Wellenformdaten speichert, wobei die zweiten Wellenformdaten eine entgegengesetzte Phase von Wellenformdaten sind, die einem Teil der ersten Wellenformdaten entsprechen, der einen bestimmten Begrenzungspegel überschreitet;

ein erstes System (373), das mindestens einen ersten Wellengenerator (3731) aufweist;

ein zweites System (374), das mindestens einen zweiten Wellengenerator (3741) aufweist;

Mittel zum Eingeben der ersten Wellenformdaten in den ersten Wellengenerator (3731) des ersten Systems und der zweiten Wellenformdaten in einen zweiten Wellengenerator (3741) des zweiten Systems auf der Grundlage einer Benutzerbedienung an mindestens einem Bedienungselement (361);

Mittel zum Erzeugen von Additionsdaten (375) durch Addieren, nach einem Additionsverhältnis, der ersten Ausgabedaten, die von dem ersten System (373) in Reaktion auf die Eingabe der ersten Wellenformdaten ausgegeben werden, und der zweiten Ausgabedaten, die von dem zweiten System (374) in Reaktion auf die Eingabe der zweiten Wellenformdaten ausgegeben werden; und

Mittel zum Steuern des Additionsverhältnisses in dem Mittel zum Erzeugen von Additionsdaten (375), sodass der Verzerrungsgrad der Additionsdaten umso größer wird, je höher das Additionsverhältnis der zweiten Ausgabedaten zu den ersten Ausgabedaten wird.

2. Elektronisches Musikinstrument nach Anspruch 1, wobei

das erste System den ersten Wellengenerator (3731), ein Normalwellenformfilter (3732) und einen ersten Wellenformverstärker (3733) aufweist, der zur Ausgabe der ersten Ausgabedaten konfiguriert ist, und

das zweite System den zweiten Wellengenerator (3741), ein Differenzwellenformfilter (3742) und einen zweiten Wellenformverstärker (3743) aufweist, der zur Ausgabe der zweiten Ausgabedaten konfiguriert ist.

3. Elektronisches Musikinstrument nach Anspruch 2, wobei ein Verzerrungsgrad der Additionsdaten grö-

ßer ist, wenn das Additionsverhältnis der zweiten Ausgabedaten (374) zu den ersten Ausgabedaten (373) ein Wert größer als 1 ist, und kleiner ist, wenn das Additionsverhältnis ein Wert kleiner als 1 ist.

4. Elektronisches Musikinstrument nach Anspruch 2 oder 3, weiter umfassend:

Mittel zum Erfassen (3736) einer Hüllkurve der ersten Ausgabedaten (373), die von dem ersten Wellenformverstärker (3733) ausgegeben werden;

Mittel zum Erzeugen (3746) einer Hüllkurve, die einem eingestellten Schwellenwert entspricht; und

Mittel zum Einstellen eines Ausgabewerts der zweiten Ausgabedaten (374), die von dem zweiten Wellenformverstärker (3743) ausgegeben werden, basierend auf einer Differenz zwischen der erfassten Hüllkurve der ersten Ausgabedaten (373) und der Hüllkurve, die dem eingestellten Schwellenwert entspricht.

5. Elektronisches Musikinstrument nach Anspruch 4, wobei eine Wellenform von Ausgabewerten der zweiten Ausgabedaten (374), wenn die Differenz eine erste Differenz ist, kleiner ist als eine Wellenform von Ausgabewerten der zweiten Ausgabedaten (374), wenn die Differenz eine zweite Differenz ist, die größer als die erste Differenz ist.

6. Elektronisches Musikinstrument nach Anspruch 4 oder 5, wobei der eingestellte Schwellenwert in Abhängigkeit von einem Musikinstrument bestimmt wird, das aufgrund einer Benutzerbedienung aus einer Vielzahl von Musikinstrumenten ausgewählt wird.

7. Elektronisches Musikinstrument nach Anspruch 6, wobei eine Wellenform der zweiten Ausgabedaten, die addiert wird, wenn eine Gitarre aus der Vielzahl von Musikinstrumenten ausgewählt wird, größer ist als eine Wellenform der zweiten Ausgabedaten, die addiert wird, wenn ein Klavier aus der Vielzahl von Musikinstrumenten ausgewählt wird.

8. Verfahren umfassend:

Speichern von ersten Wellenformdaten und zweiten Wellenformdaten in einem Speicher, wobei die zweiten Wellenformdaten eine entgegengesetzte Phase von Wellenformdaten sind, die einem Teil der ersten Wellenformdaten entsprechen, der einen bestimmten Begrenzungspegel überschreitet;

Eingeben der ersten Wellenformdaten in einen ersten Wellengenerator (3731) eines ersten Systems (373) und der zweiten Wellenformda-

- ten in einen zweiten Wellengenerator (3741) eines zweiten Systems (374) auf der Grundlage einer Benutzerbedienung an mindestens einem Bedienelement (361),
Erzeugen von Additionsdaten durch Addieren, nach einem Additionsverhältnis, der ersten Ausgabedaten, die von dem ersten System (373) in Reaktion auf die Eingabe der ersten Wellenformdaten ausgegeben werden, und der zweiten Ausgabedaten, die von dem zweiten System (374) in Reaktion auf die Eingabe der zweiten Wellenformdaten ausgegeben werden; und Steuern des Additionsverhältnisses, sodass der Verzerrungsgrad der Additionsdaten umso größer wird, je höher das Additionsverhältnis der zweiten Ausgabedaten zu den ersten Ausgabedaten wird.
9. Verfahren nach Anspruch 8, wobei ein Verzerrungsgrad der Additionsdaten größer ist, wenn das Additionsverhältnis der zweiten Ausgabedaten (374) zu den ersten Ausgabedaten (373) ein Wert größer als 1 ist, und kleiner ist, wenn das Additionsverhältnis ein Wert kleiner als 1 ist.
10. Verfahren nach Anspruch 9, weiter umfassend:
- Erfassen (3736) einer Hüllkurve der ersten Ausgabedaten (373), die von dem ersten Wellenformverstärker (3733) ausgegeben werden;
Erzeugen (3746) einer Hüllkurve, die einem eingestellten Schwellenwert entspricht; und Einstellen eines Ausgabewertes der zweiten Ausgabedaten (374), die von dem zweiten Wellenformverstärker (3743) ausgegeben werden, basierend auf einer Differenz zwischen der erfassten Hüllkurve der ersten Ausgabedaten (373) und der Hüllkurve, die dem eingestellten Schwellenwert entspricht.
11. Verfahren nach Anspruch 10, wobei eine Wellenform von Ausgabewerten der zweiten Ausgabedaten (374), wenn die Differenz eine erste Differenz ist, kleiner ist als eine Wellenform von Ausgabewerten der zweiten Ausgabedaten (374), wenn die Differenz eine zweite Differenz ist, die größer als die erste Differenz ist.
12. Verfahren nach Anspruch 10 oder 11, wobei der eingestellte Schwellenwert in Abhängigkeit von einem Musikinstrument bestimmt wird, das aufgrund einer Benutzerbedienung aus einer Vielzahl von Musikinstrumenten ausgewählt wird.
13. Verfahren nach Anspruch 12, wobei eine Wellenform der zweiten Ausgabedaten, die addiert wird, wenn eine Gitarre aus der Vielzahl von Musikinstrumenten ausgewählt wird, größer ist als eine Wellenform der zweiten Ausgabedaten, die addiert wird, wenn ein Klavier aus der Vielzahl von Musikinstrumenten ausgewählt wird.
14. Programm, das einen Computer veranlasst, einen Prozess auszuführen, wobei der Prozess umfasst:
- Speichern von ersten Wellenformdaten und zweiten Wellenformdaten in einem Speicher, wobei die zweiten Wellenformdaten eine entgegengesetzte Phase von Wellenformdaten sind, die einem Teil der ersten Wellenformdaten entsprechen, der einen bestimmten Begrenzungspegel überschreitet;
Eingeben der ersten Wellenformdaten in einen ersten Wellengenerator (3731) eines ersten Systems (373) und der zweiten Wellenformdaten in einen zweiten Wellengenerator (3741) eines zweiten Systems (374) auf der Grundlage einer Benutzerbedienung an mindestens einem Bedienelement (361),
Erzeugen von Additionsdaten durch Addieren, nach einem Additionsverhältnis, der ersten Ausgabedaten, die von dem ersten System (373) in Reaktion auf die Eingabe der ersten Wellenformdaten ausgegeben werden, und der zweiten Ausgabedaten, die von dem zweiten System (374) in Reaktion auf die Eingabe der zweiten Wellenformdaten ausgegeben werden; und Steuern des Additionsverhältnisses, sodass der Verzerrungsgrad der Additionsdaten umso größer wird, je höher das Additionsverhältnis der zweiten Ausgabedaten zu den ersten Ausgabedaten wird.

Revendications

1. Instrument de musique électronique comprenant :
- une mémoire qui stocke des premières données de forme d'onde et des secondes données de forme d'onde, dans lequel les secondes données de forme d'onde sont une phase opposée des données de forme d'onde correspondant à une partie des premières données de forme d'onde dépassant un certain niveau d'écrêtage ;
un premier système (373) qui inclut au moins un premier générateur d'ondes (3731) ;
un second système (374) qui inclut au moins un second générateur d'ondes (3741) ;
un moyen pour entrer, sur la base d'une opération de l'utilisateur sur au moins un élément d'opération (361), les premières données de forme d'onde dans le premier générateur d'ondes (3731) du premier système et les secondes données de forme d'onde dans un second générateur d'ondes (3741) du second système ;

- un moyen pour générer des données d'addition (375) en additionnant, selon un rapport d'addition, les premières données de sortie délivrées par le premier système (373) en réponse à l'entrée des premières données de forme d'onde et les secondes données de sortie délivrées par le second système (374) en réponse à l'entrée des secondes données de forme d'onde ; et un moyen pour commander le rapport d'addition, dans le moyen pour générer des données d'addition (375), de telle sorte que plus le rapport d'addition des secondes données de sortie aux premières données de sortie est élevé, plus le degré de distorsion des données d'addition est élevé.
- 5
2. Instrument de musique électronique selon la revendication 1, dans lequel
- le premier système inclut le premier générateur d'ondes (3731), un filtre de forme d'onde normale (3732), un premier amplificateur de forme d'onde (3733) configuré pour délivrer les premières données de sortie, et le second système comprend le second générateur d'ondes (3741), un filtre de forme d'onde de différence (3742), un second amplificateur de forme d'onde (3743) configuré pour délivrer les secondes données de sortie.
- 10
3. Instrument de musique électronique selon la revendication 2, dans lequel un degré de distorsion des données d'addition est plus grand lorsque le rapport d'addition des secondes données de sortie (374) aux premières données de sortie (373) est une valeur supérieure à 1, et est plus petit lorsque le rapport d'addition est une valeur inférieure à 1.
- 15
4. Instrument de musique électronique selon la revendication 2 ou 3, comprenant en outre :
- un moyen pour détecter (3736) une enveloppe des premières données de sortie (373) délivrées par le premier amplificateur de forme d'onde (3733) ; un moyen pour générer (3746) une enveloppe correspondant à une valeur de seuil fixée ; et un moyen pour ajuster une valeur de sortie des secondes données de sortie (374) délivrées par le second amplificateur de forme d'onde (3743), sur la base d'une différence entre l'enveloppe détectée des premières données de sortie (373) et l'enveloppe correspondant à la valeur de seuil fixée.
- 20
5. Instrument de musique électronique selon la revendication 4, dans lequel une forme d'onde de valeurs de sortie des secondes données de sortie (374) lors-
- que la différence est une première différence est inférieure à une forme d'onde de valeurs de sortie des secondes données de sortie (374) lorsque la différence est une seconde différence supérieure à la première différence.
- 25
6. Instrument de musique électronique selon la revendication 4 ou 5, dans lequel la valeur de seuil fixée est déterminée en fonction d'un instrument de musique qui est sélectionné sur la base d'une opération de l'utilisateur parmi une pluralité d'instruments de musique.
- 30
7. Instrument de musique électronique selon la revendication 6, dans lequel une forme d'onde des secondes données de sortie qui sont additionnées lorsqu'une guitare est sélectionnée parmi la pluralité d'instruments de musique est supérieure à une forme d'onde des secondes données de sortie qui sont additionnées lorsqu'un piano est sélectionné parmi la pluralité d'instruments de musique.
- 35
8. Procédé comprenant de :
- stocker des premières données de forme d'onde et des secondes données de forme d'onde dans une mémoire, dans lequel les secondes données de forme d'onde sont une phase opposée des données de forme d'onde correspondant à une partie des premières données de forme d'onde dépassant un certain niveau d'écrtage ; entrer, sur la base d'une opération de l'utilisateur sur au moins un élément d'opération (361), les premières données de forme d'onde dans un premier générateur d'ondes (3731) d'un premier système (373) et les secondes données de forme d'onde dans un second générateur d'ondes (3741) d'un second système (374), générer des données d'addition en additionnant, selon un rapport d'addition, les premières données de sortie délivrées par le premier système (373) en réponse à l'entrée des premières données de forme d'onde et les secondes données de sortie délivrées par le second système (374) en réponse à l'entrée des secondes données de forme d'onde ; et commander le rapport d'addition de telle sorte que plus le rapport d'addition des secondes données de sortie aux premières données de sortie est élevé, plus le degré de distorsion des données d'addition est élevé.
- 40
9. Procédé selon la revendication 8, dans lequel un degré de distorsion des données d'addition est plus grand lorsque le rapport d'addition des secondes données de sortie (374) aux premières données de sortie (373) est une valeur supérieure à 1, et est plus petit lorsque le rapport d'addition est une valeur in-
- 45
- 50
- 55

férieure à 1.

10. Procédé selon la revendication 9, comprenant en outre de :

détecter (3736) une enveloppe des premières données de sortie (373) délivrées par le premier amplificateur de forme d'onde (3733) ;
généraliser (3746) une enveloppe correspondant à une valeur de seuil fixée ; et
ajuster une valeur de sortie des secondes données de sortie (374) délivrées par le second amplificateur de forme d'onde (3743), sur la base d'une différence entre l'enveloppe détectée des premières données de sortie (373) et l'enveloppe correspondant à la valeur de seuil fixée.

5

10

15

11. Procédé selon la revendication 10, dans lequel une forme d'onde de valeurs de sortie des secondes données de sortie (374) lorsque la différence est une première différence est inférieure à une forme d'onde de valeurs de sortie des secondes données de sortie (374) lorsque la différence est une seconde différence supérieure à la première différence.

20

25

12. Procédé selon la revendication 10 ou 11, dans lequel la valeur de seuil fixée est déterminée en fonction d'un instrument de musique qui est sélectionné sur la base d'une opération de l'utilisateur parmi une pluralité d'instruments de musique.

30

13. Procédé selon la revendication 12, dans lequel une forme d'onde des secondes données de sortie qui sont additionnées lorsqu'une guitare est sélectionnée parmi la pluralité d'instruments de musique est supérieure à une forme d'onde des secondes données de sortie qui sont additionnées lorsqu'un piano est sélectionné parmi la pluralité d'instruments de musique.

35

40

14. Programme pour amener un ordinateur à exécuter un processus, le processus comprenant de :

stocker de premières données de forme d'onde et de secondes données de forme d'onde dans une mémoire, dans lequel les secondes données de forme d'onde sont une phase opposée des données de forme d'onde correspondant à une partie des premières données de forme d'onde dépassant un certain niveau d'écrtage ;
entrer, sur la base d'une opération de l'utilisateur sur au moins un élément d'opération (361), les premières données de forme d'onde dans un premier générateur d'ondes (3731) d'un premier système (373) et les secondes données de forme d'onde dans un second générateur d'ondes (3741) d'un second système (374),
généraliser des données d'addition en addition-

45

50

55

nant, selon un rapport d'addition, les premières données de sortie délivrées par le premier système (373) en réponse à l'entrée des premières données de forme d'onde et les secondes données de sortie délivrées par le second système (374) en réponse à l'entrée des secondes données de forme d'onde ; et
commander le rapport d'addition de telle sorte que plus le rapport d'addition des secondes données de sortie aux premières données de sortie est élevé, plus le degré de distorsion des données d'addition est élevé.

FIG. 1A

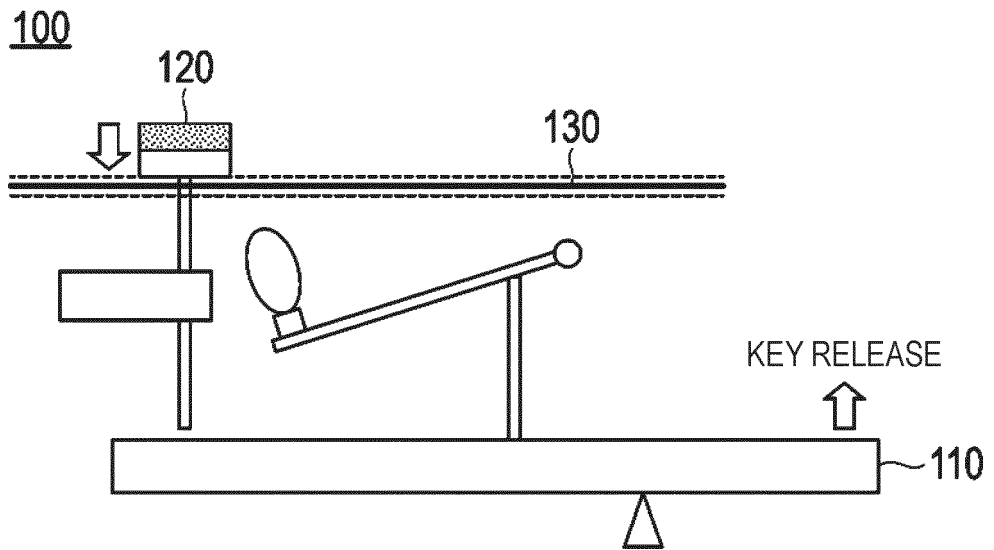

FIG. 1B

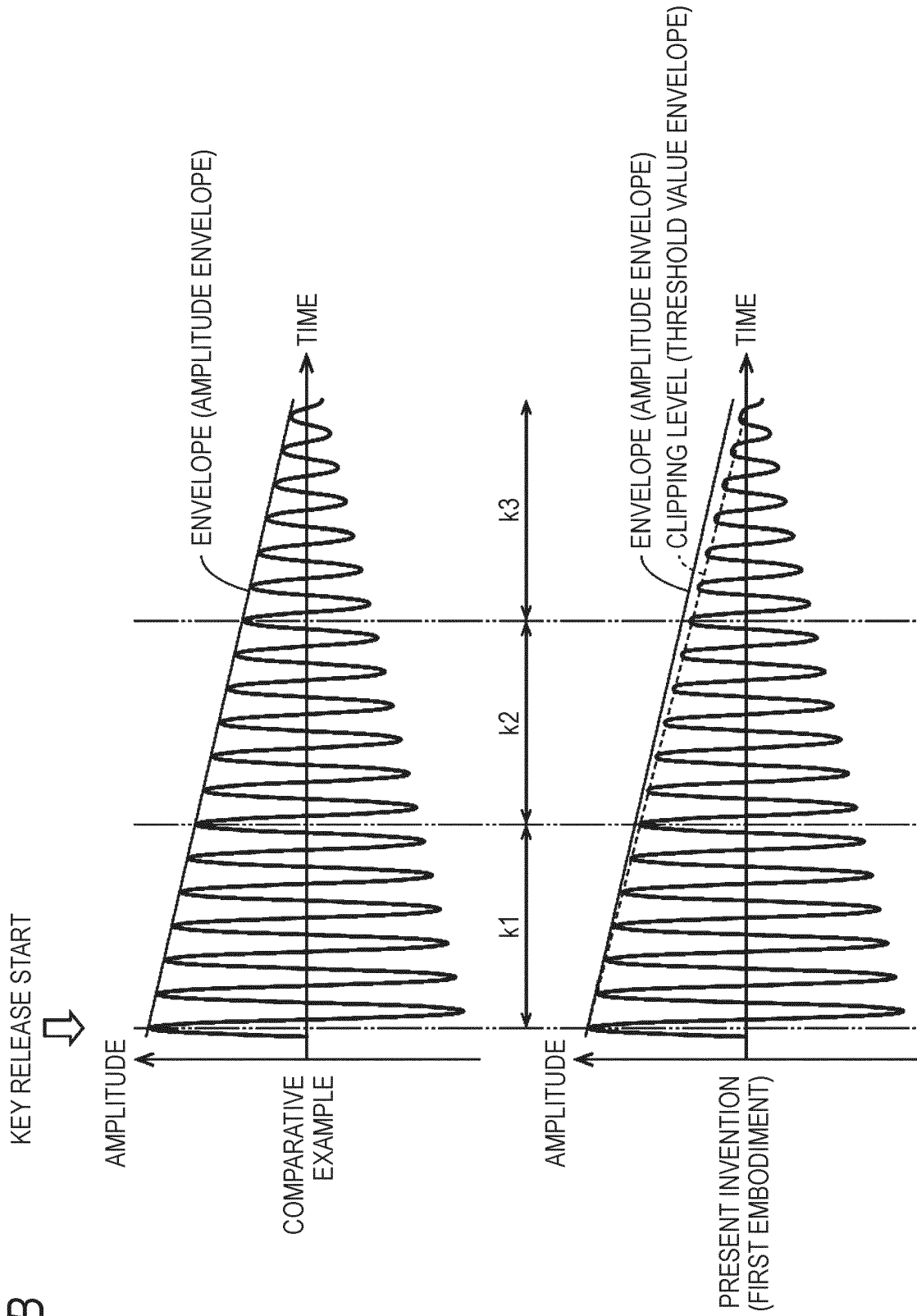

FIG. 2A

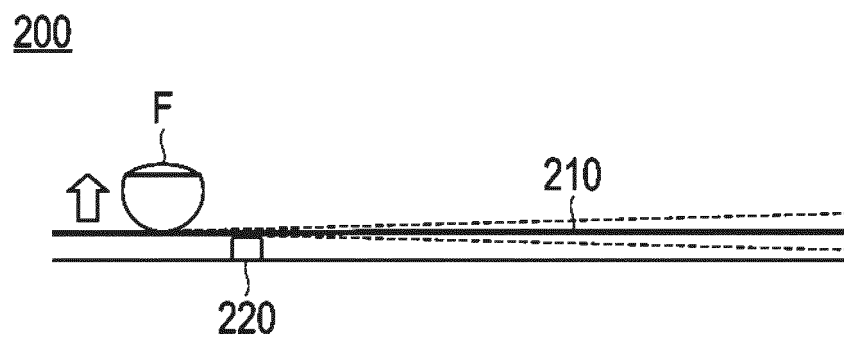

FIG. 2B

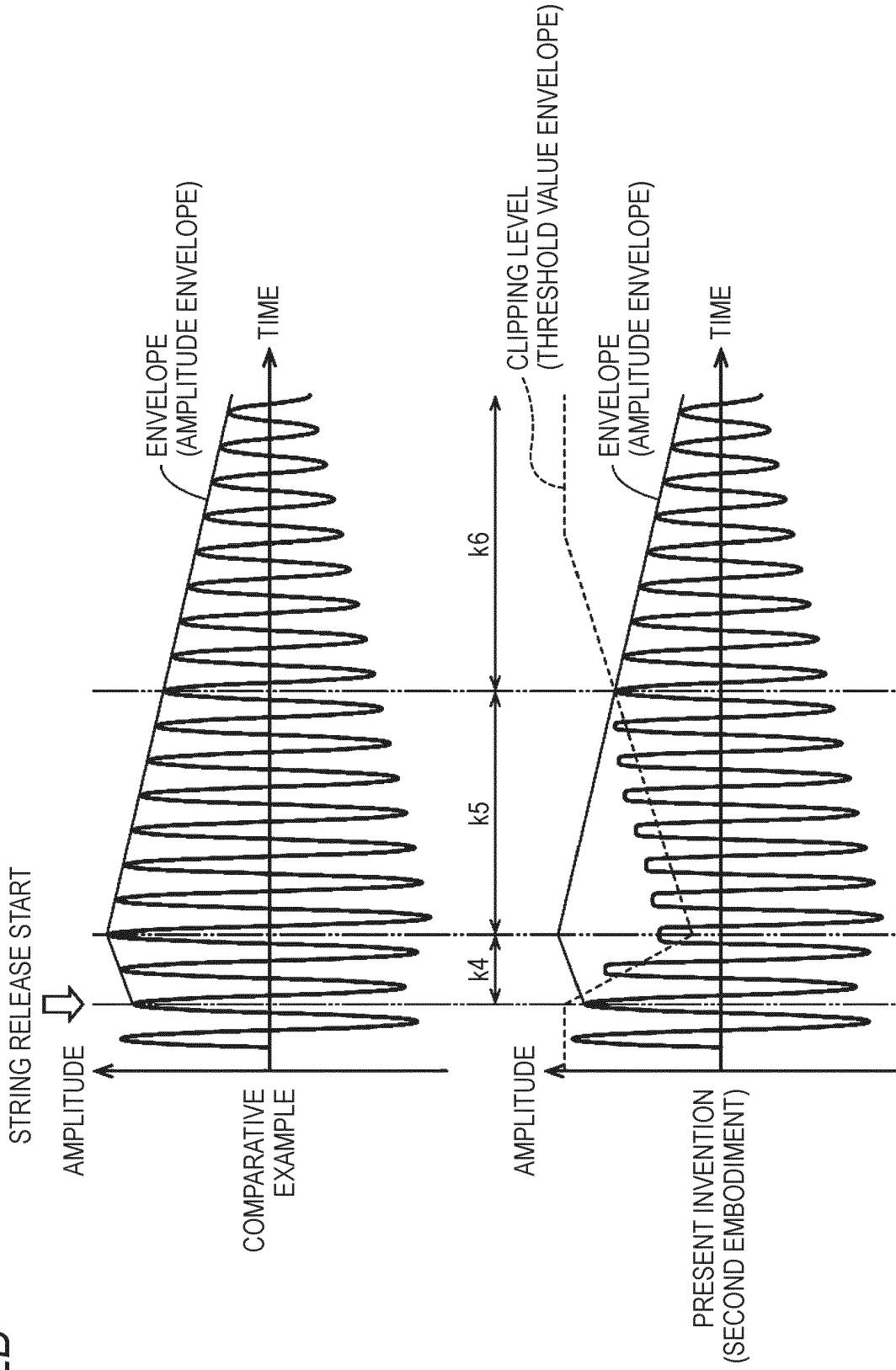

FIG. 3

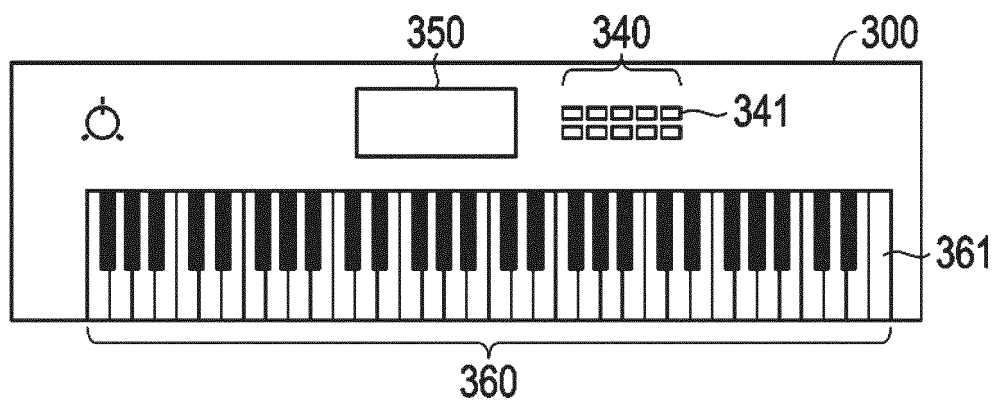

FIG. 4

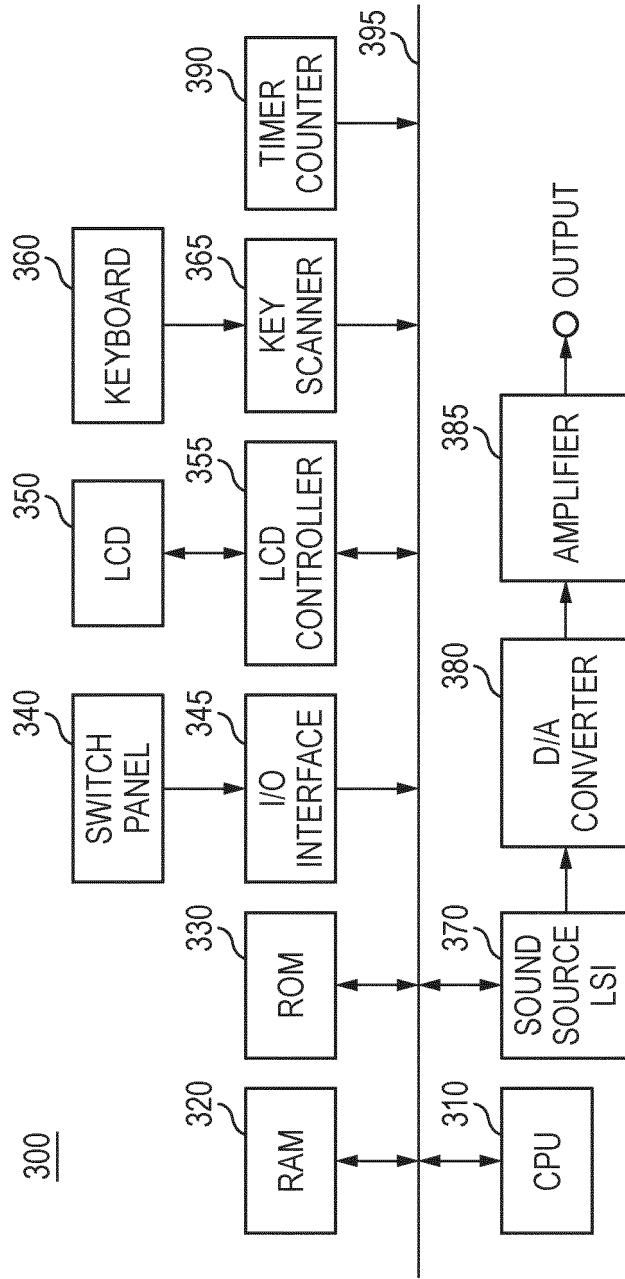

FIG. 5

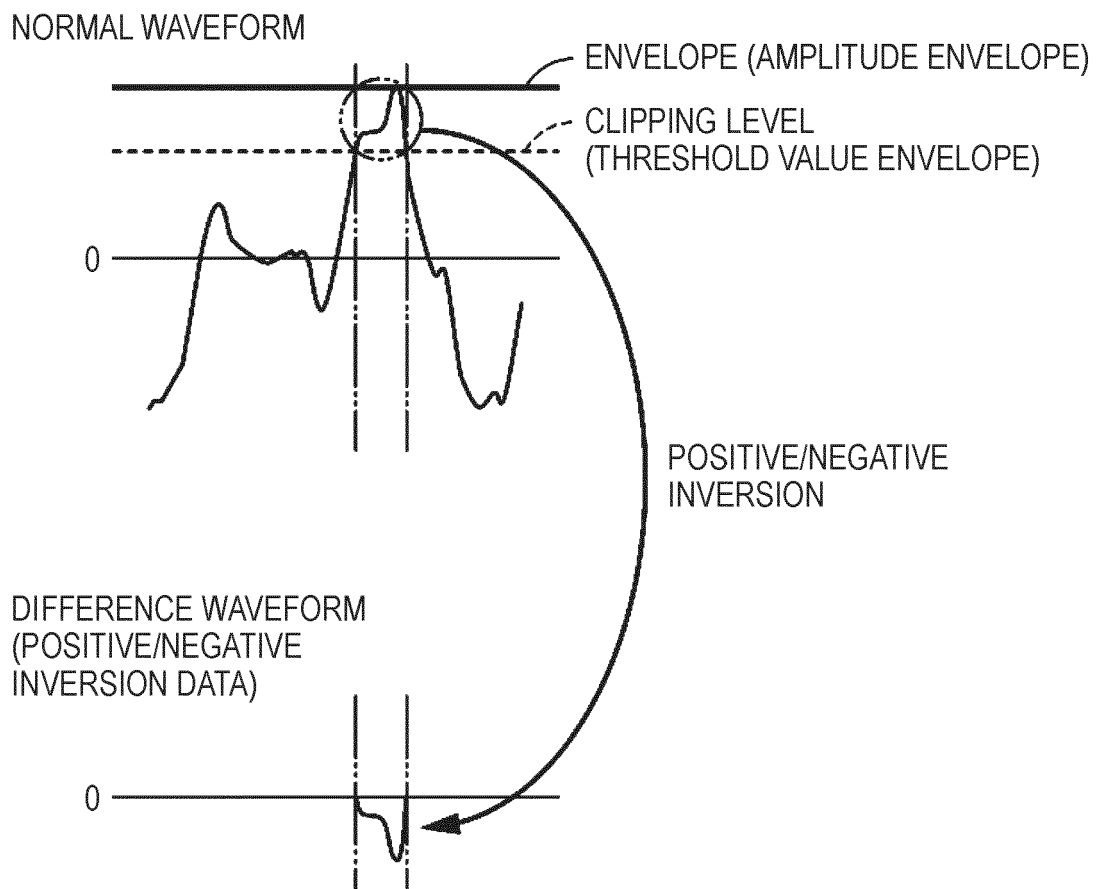

FIG. 6

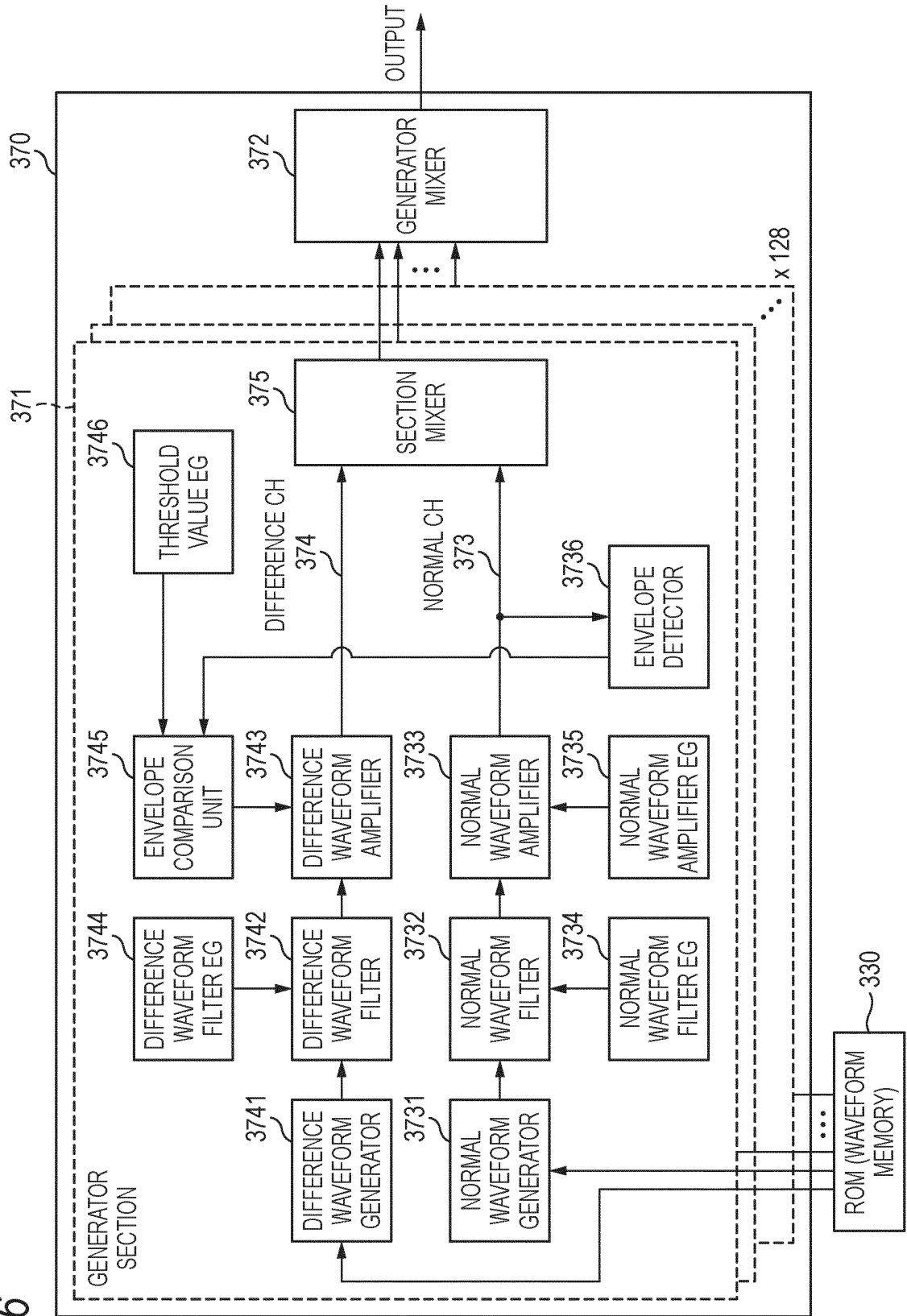

FIG. 7

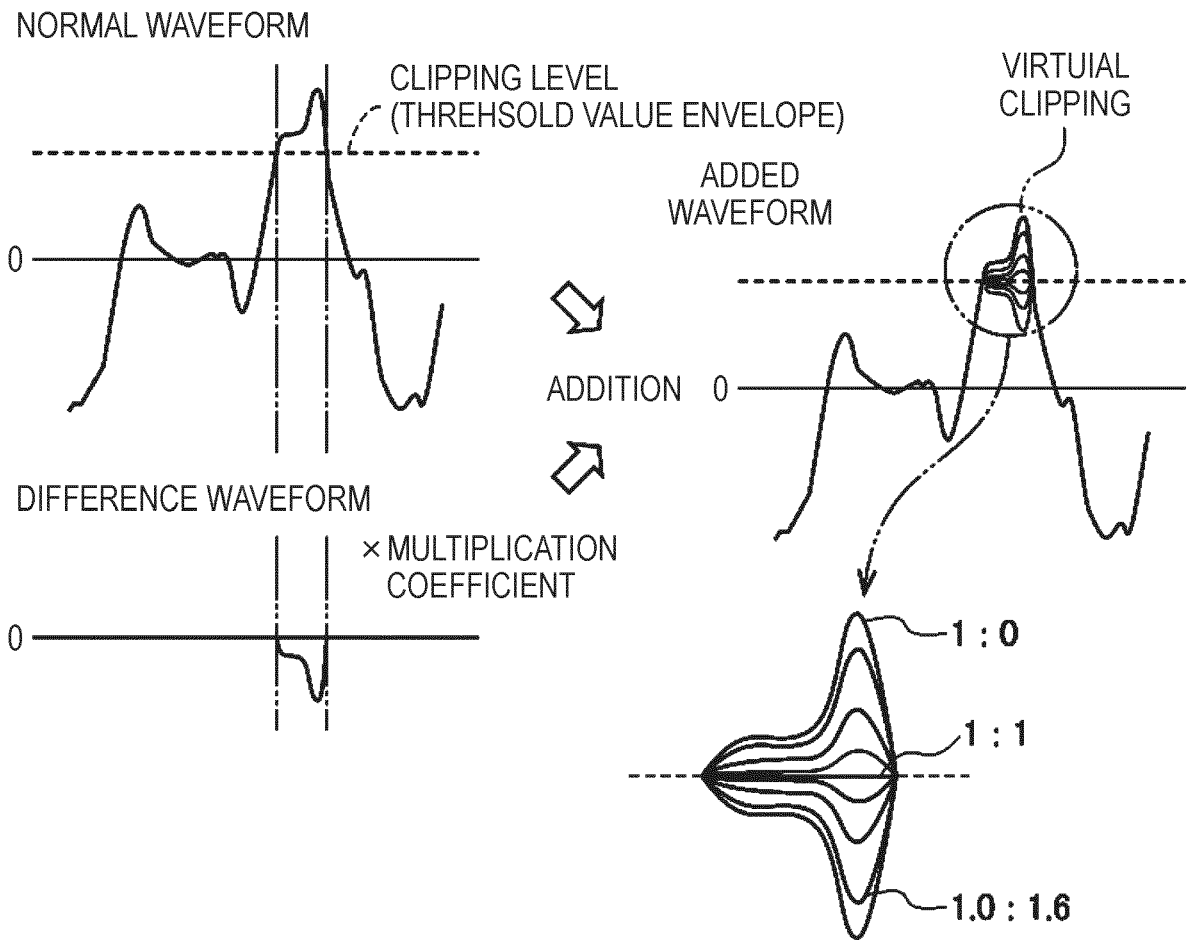

FIG. 8A

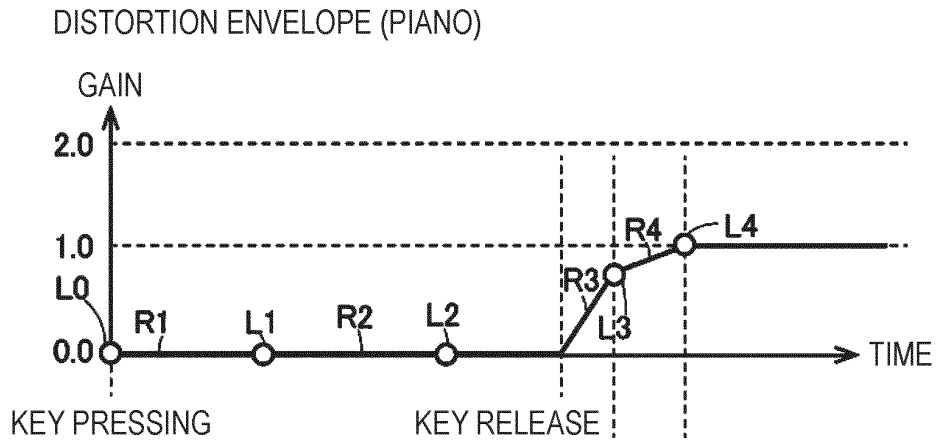

FIG. 8B

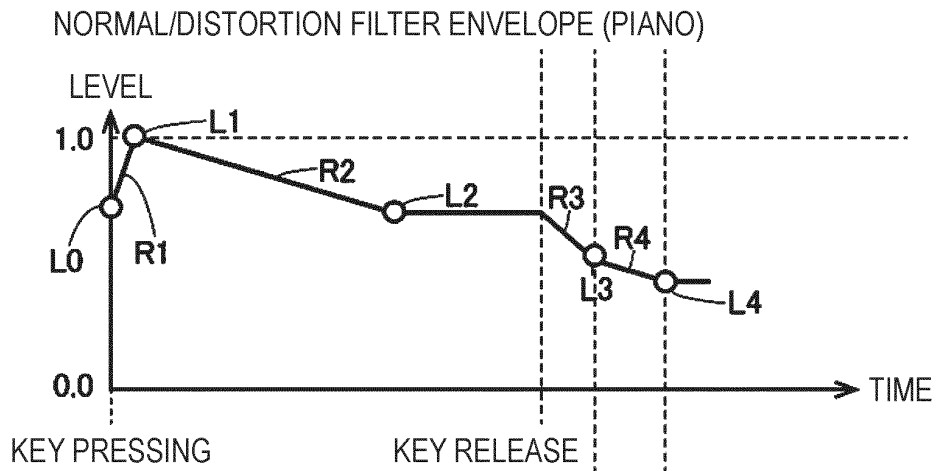

FIG. 8C

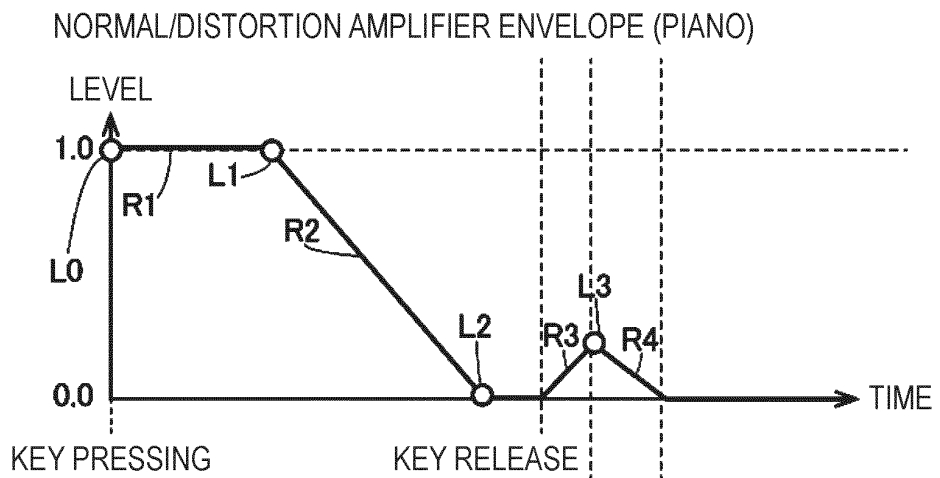

FIG. 9A

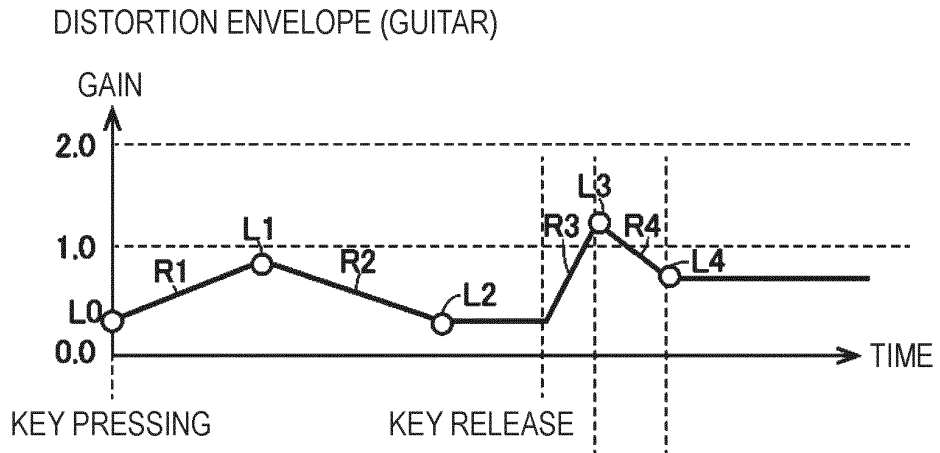

FIG. 9B

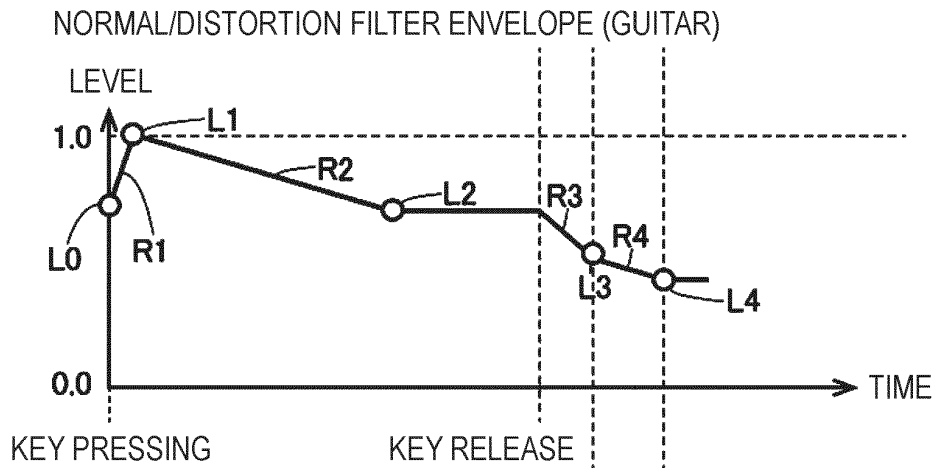

FIG. 9C

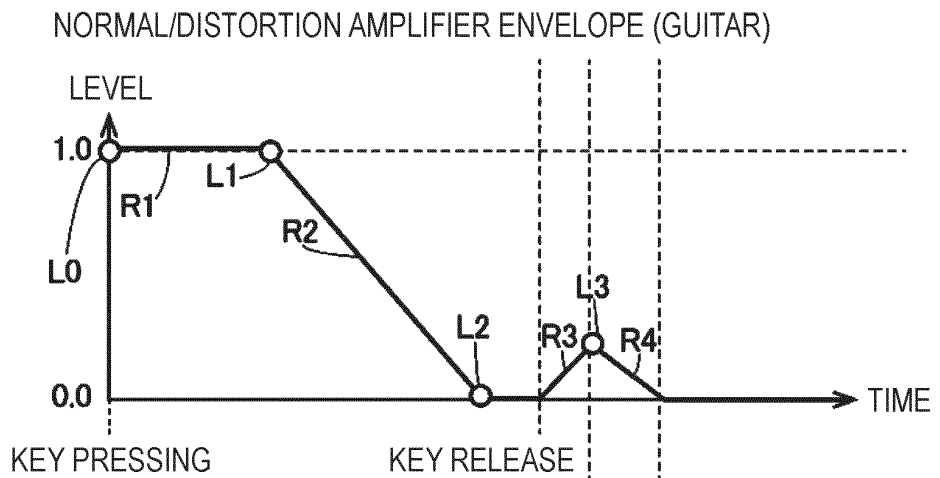

FIG. 10

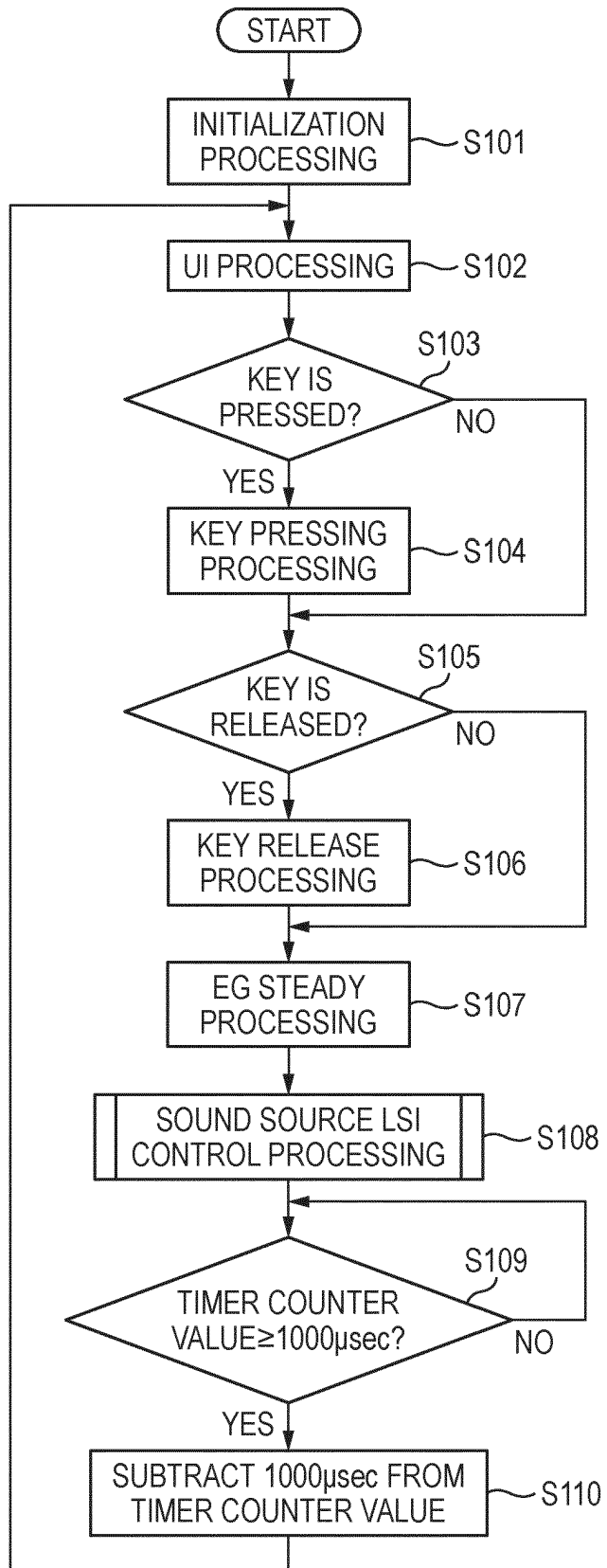
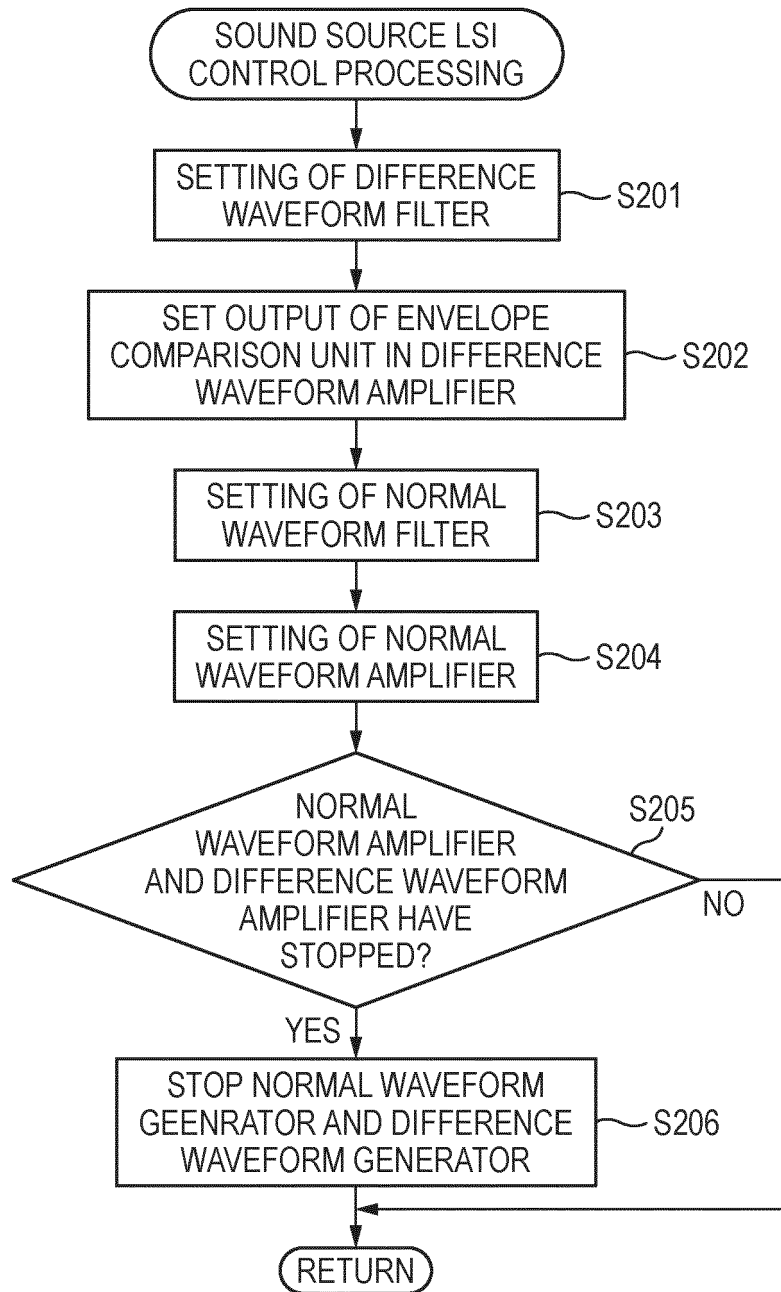

FIG. 11



REFERENCES CITED IN THE DESCRIPTION

This list of references cited by the applicant is for the reader's convenience only. It does not form part of the European patent document. Even though great care has been taken in compiling the references, errors or omissions cannot be excluded and the EPO disclaims all liability in this regard.

Patent documents cited in the description

- JP 2011154394 A [0003] [0004]
- US 2009080677 A1 [0005]
- US 5147970 A [0006]
- US 2008245213 A1 [0007]