



(12) **EUROPEAN PATENT APPLICATION**

(43) Date of publication:
06.01.2021 Bulletin 2021/01

(51) Int Cl.:
E04F 15/04 (2006.01) E04F 15/02 (2006.01)

(21) Application number: **20192928.8**

(22) Date of filing: **11.07.2012**

(84) Designated Contracting States:
AL AT BE BG CH CY CZ DE DK EE ES FI FR GB GR HR HU IE IS IT LI LT LU LV MC MK MT NL NO PL PT RO RS SE SI SK SM TR

(72) Inventors:

- **PERVAN, Darko**
SE-263 61 VIKEN (SE)
- **PERVAN, Tony**
SE-114 59 STOCKHOLM (SE)

(30) Priority: **19.07.2011 SE 1150713**
19.07.2011 US 201161509309 P

(74) Representative: **Välinge Innovation AB**
Patent Department
Prästavägen 513
263 65 Viken (SE)

(62) Document number(s) of the earlier application(s) in accordance with Art. 76 EPC:
16184205.9 / 3 135 838
12815189.1 / 2 734 684

Remarks:
This application was filed on 26-08-2020 as a divisional application to the application mentioned under INID code 62.

(71) Applicant: **Ceraloc Innovation AB**
263 65 Viken (SE)

(54) **MECHANICAL LOCKING SYSTEM FOR BUILDING PANELS**

(57) In accordance with the present inventive concept, there is provided building panels provided with a locking system for vertical locking of a first (1) and a second (1') building panel by a vertical displacement of the panels relative each other. A displaceable tongue (30) provided in a sidewardly open displacement groove (40)

at an edge of the second building panel is configured to be displaced into a tongue groove (20) of the first building panel when a tongue pressing surface (32) provided on the displaceable tongue and a strip pressing surface (33) provided on a strip (8) of the first building panel are displaced vertically against each other.

Fig. 2a

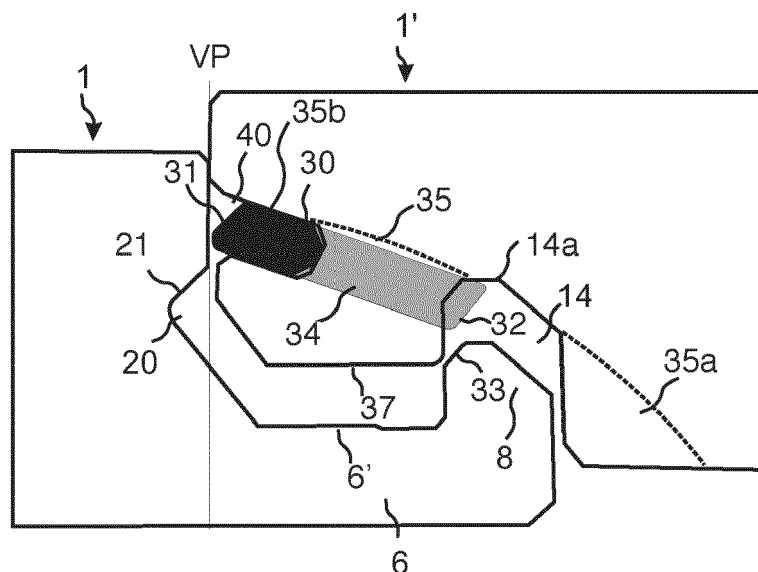

Description

TECHNICAL FIELD

[0001] The disclosure generally relates to the field of mechanical locking systems for floor panels and building panels. The disclosure shows floorboards, locking systems, installation methods and production methods.

FIELD OF APPLICATION OF THE INVENTION

[0002] The present invention is particularly suitable for use in floating floors, which are formed of floor panels which are joined mechanically with a locking system integrated with the floor panel, i.e. mounted at the factory, are made up of one or more upper layers of veneer, decorative laminate powder based surfaces or decorative plastic material, an intermediate core of wood-fibre-based material or plastic material and preferably a lower balancing layer on the rear side of the core.

[0003] The following description of known technique, problems of known systems and objects and features of the invention will therefore, as a non-restrictive example, be aimed above all at this field of application and in particular at panels formed as rectangular floor panels with long and short edges intended to be mechanically joined to each other on both long and short edges.

[0004] The long and short edges are mainly used to simplify the description of the invention. The panels may be square. The invention is preferably used on the short edges. It should be emphasised that the invention may be used in any floor panel and it may be combined with all types of known locking system formed on the long edges, where the floor panels are intended to be joined using a mechanical locking system connecting the panels in the horizontal and vertical directions on at least two adjacent sides.

[0005] The invention may also be applicable to, for instance, solid wooden floors, parquet floors with a core of wood or wood-fibre-based material and a surface of wood or wood veneer and the like, floors with a printed and preferably also varnished surface, floors with a surface layer of plastic or cork, linoleum, rubber. Even floors with hard surfaces such as stone, tile and similar materials are included and floorings with soft wear layer, for instance needle felt glued to a board. The invention may also be used for joining building panels which preferably contain a board material for instance wall panels, ceilings, furniture components and similar.

BACKGROUND OF THE INVENTION

[0006] Laminate flooring usually comprises a core of a 6-12 mm fibre board, a 0.2-0.8 mm thick upper decorative surface layer of laminate and a 0.1-0.6 mm thick lower balancing layer of laminate, plastic, paper or like material. A laminate surface comprises of melamine-impregnated paper. The most common core material is fi-

breboard with high density and good stability usually called HDF - High Density Fibreboard. Sometimes also MDF - Medium Density Fibreboard - is used as core.

[0007] Traditional laminate floor panels of this type have been joined by means of glued tongue-and-groove joints.

In addition to such traditional floors, floor panels have been developed which do not require the use of glue and instead are joined mechanically by means of so-called mechanical locking systems. These systems comprise locking means, which lock the panels horizontally and vertically. The mechanical locking systems are usually formed by machining of the core of the panel. Alternatively, parts of the locking system may be formed of a separate material, for instance aluminium or HDF, which is integrated with the floor panel, i.e. joined with the floor panel in connection with the manufacture thereof.

[0008] The main advantages of floating floors with mechanical locking systems are that they are easy to install. They may also easily be taken up again and used once more at a different location.

DEFINITION OF SOME TERMS

[0009] In the following text, the visible surface of the installed floor panel is called "*front side*", while the opposite side of the floor panel, facing the sub floor, is called "*rear side*". The edge between the front and rear side is called "*joint edge*". By "*horizontal plane*" is meant a plane, which extends parallel to the outer part of the surface layer. Immediately juxtaposed upper parts of two adjacent joint edges of two joined floor panels together define a "*vertical plane*" perpendicular to the horizontal plane. By "*vertical locking*" is meant locking parallel to the vertical plane in D1 direction. By "*horizontal locking*" is meant locking parallel to the horizontal plane in D2 direction.

[0010] By "*up*" is meant towards the front side, by "*down*" towards the rear side, by "*inwardly*" mainly horizontally towards an inner and centre part of the panel and by "*outwardly*" mainly horizontally away from the centre part of the panel.

[0011] By "*locking systems*" are meant co acting connecting elements, which connect the floor panels vertically and/or horizontally.

RELATED ART AND PROBLEMS THEREOF

[0012] For mechanical joining of long edges as well as short edges in the vertical and in the first horizontal direction perpendicular to the edges several methods may be used. One of the most used methods is the angle-snap method. The long edges are installed by angling. The panel is then displaced in locked position along the long side. The short edges are locked by horizontal snapping. The vertical connection is generally a tongue and a groove. During the horizontal displacement, a strip with a locking element is bent and when the edges are in contact, the strip springs back and a locking element en-

ters a locking groove and locks the panels horizontally. Such a snap connection is complicated since a hammer and a tapping block may need to be used to overcome the friction between the long edges and to bend the strip during the snapping action.

[0013] Similar locking systems may also be produced with a rigid strip and they are connected with an angling-angling method where both short and long edges are angled into a locked position.

[0014] Recently new and very efficient locking systems have been introduced with a separate flexible or displaceable integrated tongue on the short edge that allows installation with only an angling action, generally referred to as "vertical folding". Such a system is described in WO 2006/043893 (Valinge Innovation AB).

[0015] Several versions are used on the market as shown in figures 1a-1f. Figure 1a, 1b show a flexible tongue 30 with a flexible snap tab extending from the edge. Figure 1c, 1d show a displaceable tongue with an inner flexible part that is bendable horizontally in a cross section of the tongue or along the joint. Such systems are referred to as vertical snap systems and they provide an automatic locking during the folding action.

[0016] The locking system may also be locked with a side push action such that a displaceable tongue 30 is pushed into a locked position from the long side edge when adjacent sort side edges are folded down to the sub floor. Such a side push action could be difficult to combine with a simple angling and the friction may be too strong for wide panels.

[0017] Figure 1e shows a fold down system with a flexible tongue 30 that is made in one piece with the core. Figure 1f shows a long edge locking system in a fold down system that is connected with angling.

[0018] Although such systems are very efficient, there is still room for improvements. Vertical snap systems are designed with the tongue on the strip panel. The reason is that an inclined sliding surface can only be formed on the fold panel when the upper edges are made without a bevel and this is generally the case. It is difficult to insert the separate tongue 30 during production into a groove 40 over a strip 6 comprising a locking element 8. The locking force is dependant on the snapping resistance. High locking force can only be accomplished with high snapping resistance when the tongue is pressed inwardly and when it snaps back into a tongue groove 40. This creates separation forces that tend to push the panels apart during folding. The locking may lose its strength if the flexibility and pressing force of the tongue decreases over time. The flexibility must be considerable and allow that a flexible tongue is displaced in two directions about 1-2 mm. The material, which is used to produce such tongues, is rather expensive and glass fibres are generally used to reinforce the flexible tongue.

[0019] It would be a major advantage if the separate tongue could be fixed to the fold panel and if snapping could be eliminated in a system that locks automatically during folding.

SUMMARY

[0020] An overall objective of embodiments of the present invention is to provide a locking system for primarily rectangular floor panels with long and short edges installed in parallel rows, which allows that the short edges may be locked to each other automatically without a snap action that creates a locking resistance and separation forces of the short edges during folding. A specific objective is to provide a locking system with a separate displaceable tongue on the fold panel that may lock without any contact with the sharp upper edge of the strip panel and that the tongue is displaced essentially in one direction only from an inner part of a groove and outwardly.

[0021] The above objects of embodiments of the invention are achieved wholly or partly by locking systems and floor panels according to the independent claims. Embodiments of the invention are evident from the dependent claims and from the description and drawings.

[0022] A first aspect of the invention are building panels provided with a locking system for vertical locking of a first and a second building panel by a vertical displacement of the panels relative each other. A sidewardly open tongue groove is provided at an edge of the first building panel. A strip protrudes below the tongue groove and outwardly beyond the upper part of the edge of said first panel. A displaceable tongue is provided in a sidewardly open displacement groove at an edge of the second building panel. The displaceable tongue comprises a main body extending along the edge of the second panel and preferably a tongue locking surface, located at an upper and outer part of the displaceable tongue, configured to cooperate with a groove locking surface of the tongue groove for a vertical locking of the first and the second building panel. The displaceable tongue comprises an inner part, spaced inwardly from an upper part of an edge of said second panel, the inner part comprises a tongue pressing surface configured to cooperate with a strip pressing surface on the strip. The displaceable tongue is configured to be displaced into the tongue groove when the tongue and the strip pressing surface are displaced vertically against each other to obtain the vertical locking.

[0023] The displaceable tongue is preferably an injection-moulded tongue.

[0024] The displaceable tongue may be asymmetric and comprising a protrusion and the second panel may comprise a cavity for housing the protrusion.

[0025] The protrusion may comprise a flexible part.

[0026] The strip may be provided with a locking element that cooperates with a downwardly open locking groove formed on the second panel for locking the first and the second building panel in a horizontal direction.

[0027] The tongue pressing surface is preferably positioned on the protrusion and the strip pressing surface is preferably located on the locking element.

[0028] The strip pressing surface is most preferably

located on an inclined surface of the locking element that is directed towards the edge of the first building panel.

[0029] The locking system may comprise a cavity that extends from the displacement groove to the locking groove.

[0030] The strip and the tongue pressing surfaces may be inclined against a horizontal plane with an angle of about 25 to 75 degrees.

[0031] The displacement groove may be inclined and comprise an inner part that extends downwards.

[0032] The building panels may be locked vertically by two pairs of cooperating surfaces comprising the groove locking surface and the tongue locking surface, and an upper part of the strip and a lower part of the edge of the second panel, respectively.

[0033] The groove locking surface and the tongue locking surface may be inclined against a horizontal plane.

[0034] The groove locking surface and the tongue locking surface may be inclined with an angle of about 10 to 60 degrees to a horizontal plane.

[0035] The displaceable tongue may be provided with a flexible friction element.

[0036] The displaceable tongue may comprise at least two protrusions extending from the main tongue body and each protrusion may comprise said tongue pressing surface located at an outer part of the protrusion that during locking is in contact with a locking element provided on the strip.

[0037] The building panel may be a floor panel and the outer part of the displaceable tongue is preferably in an unlocked position located in the displacement groove.

[0038] The displacement groove may extend vertically above the locking groove.

[0039] The locking groove may be located vertically below the upper part of the displacement groove.

[0040] An upper part of the locking element may be located vertically below the tongue locking surface of the displaceable tongue.

[0041] An upper part of the locking groove may be located vertically below the tongue locking surface of the displaceable tongue.

[0042] The innermost part of the displaceable tongue may be below the outermost part of such tongue.

[0043] The tongue pressing surface may be located vertically below the tongue locking surface.

[0044] An upper part of the locking element may be located in the lower half of an intermediate core of the first building panel.

[0045] The strip may be flexible such that it bends downwards during locking.

[0046] The cavity may be larger than the protrusion such that there is a space S of at least about 1-3 mm.

[0047] The displaceable tongue may be gradually inserted into the tongue groove from a tongue part, which is adjacent an installed long edge, to another tongue part adjacent a free long edge.

BRIEF DESCRIPTION OF THE DRAWINGS

[0048] The disclosure will in the following be described in connection to exemplary embodiments and in greater detail with reference to the appended exemplary drawings, wherein:

Figs 1a-f illustrate locking systems according to known technology.

Figs 2a-d illustrate a short edge locking system according to an embodiment of the invention.

Figs 3a-3d illustrate a short edge locking system according to preferred embodiments of the invention.

Figs 4a-e illustrate preferred embodiments of short edge locking systems.

Figs 5a-e illustrate vertical folding of three panels according to an embodiment of the invention.

Figs 6a-e illustrate the flexibility of the locking systems during locking and preferred embodiments of displaceable tongues.

Figs 7a-c illustrate tongue blanks according to embodiments of the invention comprising several displaceable tongues.

DESCRIPTION OF EMBODIMENTS OF THE INVENTION

[0049] To facilitate understanding, several locking systems in the figures are shown schematically. It should be emphasised that improved or different functions may be achieved using combinations of the preferred embodiments.

[0050] All embodiments may be used separately or in combinations. Angles, dimensions, rounded parts, spaces between surfaces etc are only examples and may be adjusted within the basic principles of the invention. Figures 2a-2d show a first preferred embodiment of a short edge locking system provided with a flexible and displaceable tongue 30 in an edge of a second panel 1' inserted in a displacement groove 40 and extending along the edge of the second panel. The displaceable tongue 30 has a tongue locking surface 31 located at an upper and outer part that cooperates with a groove locking surface 21 located at an inner and upper part of a tongue groove 20 formed in an adjacent edge of a first panel 1. The locking surfaces lock the panels in a first vertical direction. The locking surfaces are preferably inclined with an angle A2 that is about 10 - 60 degrees. The displacement groove is preferably also inclined and the outer part is closer to the panel surface than an inner part.

[0051] The first panel 1 comprises a protruding strip 6 that extends outwardly beyond a vertical plane VP. The strip comprises a locking element 8. The second panel 1' comprises a locking groove 14 that cooperates with the locking element 8 and locks the panels in a horizontal direction. The strip 6 has an upper part 6', which is in contact with a lower part 37 of the adjacent edge and locks the panels in a second vertical direction.

[0052] The displaceable tongue 30 comprises a protrusion 34 extending from a main tongue body 36. The second panel 1' comprises at least one cavity 35 for housing the protrusion. The cavity extends from the displacement groove to the locking groove 14.

The cavity may be formed by a screw cutter or by displaceable saw blades.

The protrusion comprises a tongue pressing surface 32 which cooperates with a strip pressing surface 33 on the locking element. The strip pressing surface 33 and the tongue pressing surface 32 are inclined with an angle A1 which is preferably 25 - 75 degrees against a horizontal plane HP.

[0053] The displaceable tongue is displaced essentially in one direction towards the tongue groove 20 when the inclined pressing surfaces are sliding against each other during the vertical displacement of the adjacent edges. The tongue may be locked with a strong pressure against the groove locking surface 21 and the locking element 8 prevents the tongue from sliding back into the displacement groove.

[0054] One major problem related to a "press lock system" as described above is the risk that panel may split with a crack 50 between the displacement groove 40 and the locking groove 14 as shown in figure 2d. Therefore it is preferable that the upper parts of the locking groove 14a and the locking element 8a are made in the lower part of the floor panel, preferably below the centre line C that divides the floor panel in two equal parts, one upper part UP and one lower part LP. It is also preferable that the tongue pressing surface 32 is located vertically below the tongue locking surface 31. The tongue pressing surface and the tongue locking surface are preferably offset vertically and are preferably located on different horizontal planes H2, H1. It is also preferred that an upper part of the locking element 8a and/or an upper part of the locking groove 14a are located vertically below the tongue locking surface 31. The innermost part of the displaceable tongue 30 is preferably located below the outermost part of such tongue.

[0055] The cavities 35 are preferably formed by rotating saw blades and comprise preferably an upper rounded part with an outer part 35b that is located above an inner part 35a as shown in figure 2d. The cavity is preferably formed such that it intersects the inner part 14b of the locking groove 14.

[0056] Figures 3a -3d show the locking function during the vertical displacement of the second panel 1' against the first panel 1. The displaceable tongue 30 is gradually pressed into the tongue groove 20 by the cooperating

pressing surfaces 32,33 and the panels are locked vertically with two pairs of cooperating locking surfaces, the tongue locking surface 31 and the groove locking surface 21 and an upper part 6' of the strip 6 and a lower part 37 of the adjacent edge 1'.

[0057] Figures 4a-4e show different embodiments. Figure 4a shows a displaceable tongue 30 with a protrusion 34 located under the main tongue body. The locking groove 14 is located vertically under an upper part of the displacement groove 40. Figure 4b shows a tongue pressing surface 32 that locks against a strip pressing surface that is not active in the horizontal locking. Figure 4c shows that the same locking surface 33 on the locking element 8 may be used as a pressing surface and as a locking surface for the horizontal locking. Figure 4d shows that the strip pressing surface may be formed on a separate pushing rod 42. Figure 4e shows a protrusion 34 that comprises a curved cross section and a locking element that comprises an upper part 44 formed as local protrusion that protrudes above the inner part of the locking groove 14 and into the cavities 35.

[0058] Figures 5a -5e show vertical folding of three panels wherein the long edges 2,2' are connected with angling and the short edges 1, 1' with a scissor like motion that combines angling and vertical displacement. Figure 5b shows that the displaceable tongue is gradually inserted into the tongue groove 20 from one part of the edges that is adjacent to the installed long edge 2 to the other free long edge. Figure 5c shows the tongue in the cross section A-A and figures 5d, 5e show the tongue position in the cross sections B-B, and C-C. The strip 6 and the locking element 8 are in this embodiment designed such that they bend backwards during locking and this facilitates locking since the necessary flexibility may be provided partly or completely with such strip bending. The locking groove is positioned vertically under the lower part of the displacement groove 40.

[0059] Figure 6a shows that the locking system may be formed such that several parts are flexible for example the protrusion 34, the locking strip 6 and the locking element 8. This flexibility may be used to reduce or eliminate production tolerances and to facilitate an easy and strong locking. Figure 6a shows that the strip 6 may be bent downwards and the locking element 8 may be bent downwards and outwardly. Such a strip bending may facilitate locking that may even be accomplished with a displaceable tongue that comprises a limited flexibility such as a tongue that essentially comprises wood fibre material. A locking may be accomplished with a flexibility where a part of the displaceable tongue 30 is bended or compressed marginally for example only about 0,1 - 1,0 mm in the horizontal direction.

[0060] Figure 6b and 6c show embodiments of the tongue. The displaceable tongue 30 may be fixed into the displaceable groove with a friction connection 38. The protrusion 34 may comprise flexible parts 39 that create a pre tension against the tongue groove 20. The cavity 35 may be considerably larger than the protrusion and

preferably there is a space S that may be about 1-3 mm.

[0061] Figure 6d shows a locking system with a sliding surface 45 that protrudes beyond a vertical plane VP. The tongue groove 20 is preferably formed on an inclined edge surface 46. Such an embodiment offers the advantages that the displaceable tongue 30 may be pressed inwardly and the conventional two-way snapping action may be combined with a one way pressing motion that may be used to create the final locking.

[0062] Figure 6e shows a separate tongue 30, located in a sideways open groove 40 on the second panel 1', comprising an upwardly extending snap tab 47 that cooperates with a downwardly extending sliding surface 45 that is located on the first panel 1 and that protrudes beyond the upper edge and the vertical plane VP. The second panel 1' comprises preferably an inclined edge surface 46' located above and and/or below the tongue 30. An easy snapping may be obtained even with panels that have straight and sharp upper adjacent edges. The snap tab may be replaced with a displaceable tongue that comprises flexible snapping protrusions along its length. The locking system shown in figure 1d may also be adjusted such that it comprises inclined edge surfaces and such a design may be used to increase the strength of the joint.

[0063] The locking system according to the invention may also be formed without a locking groove 14 and a locking element 8 such that it only locks the edges in a vertical direction. The locking element 8 may be replaced with local protrusions that extend upwards from a strip 6 and are in locked position located in the cavities. The short edges may be locked horizontally by friction between the long edges.

[0064] All locking systems may be designed such that they can be unlocked with angling and/or sliding along the edges.

[0065] Figure 7a, 7b show a tongue blank 43 that comprise several displaceable tongues that are preferably asymmetric along the tongue length. Figure 7a shows injection-moulded tongues 30 and figure 7b shows displaceable tongues 30 made of a wood based material that is preferably machined and punched.

[0066] The cavities 35 that are preferably formed by rotating saw blades comprises an upper part that is rounded and may comprise an inner part that is located below an outer part.

The locking system may be partly or completely formed by carving tools.

Embodiments:

[0067]

Item 1. Building panels provided with a locking system for vertical locking of a first (1) and a second building panel (1') by a vertical displacement of the panels (1,1') relative each other, the building panels comprising:

a sidewardly open tongue groove (20) is provided at an edge of the first building panel (1), and a strip (6) protrudes below the tongue groove (20) and outwardly beyond an upper part of the edge of said first building panel (1);

a displaceable tongue (30) is provided in a sidewardly open displacement groove (40) at an edge of the second building panel, the displaceable tongue (30) comprises a main body extending along the edge of the second panel and a tongue locking surface (31) located at an upper and outer part of the tongue, the tongue locking surface is configured to cooperate for vertical locking with a groove locking surface (21) of the tongue groove (20) **characterised** in that the displaceable tongue comprises an inner part (34) spaced inwardly from an upper part of the edge of said second panel (1'),

that the inner part comprises a tongue pressing surface (32) configured to cooperate with a strip pressing surface (33) on the strip (6), such that the displaceable tongue (30) is displaced into the tongue groove when the tongue pressing surface and the strip pressing surface (32,33) are displaced vertically against each other to obtain a locking of the first and the second building panel (1,1') in a vertical direction.

Item 2. The building panels as in item 1, wherein said displaceable tongue (30) is asymmetric and comprises a protrusion (34) and the second panel (1') comprises a cavity (35) for housing the protrusion.

Item 3. The building panels as in item 2, wherein the protrusion (34) comprises a part (38) that is flexible.

Item 4. The building panels as in item 2 or 3, wherein the cavity (35) is larger than the protrusion (34) such that there is a space S of about at least about 1-3 mm.

Item 5. The building panels as in any one of the items 2-4, wherein the strip (6) comprises a locking element (8) configured to cooperate with a downwardly open locking groove (14), formed on the second panel, for locking of the first and the second building panel (1,1') in a horizontal direction.

Item 6. The building panels as in item 5, wherein the tongue pressing surface (32) is provided on the protrusion (34) and the strip pressing surface (33) is provided on the locking element (8).

Item 7. The building panels as in item 6, wherein the strip pressing surface (33) is provided at an inclined surface of the locking element (8) directed towards the first edge.

Item 8. The building panels as in item 5, wherein the

strip pressing surface (33) is provided at an upper part of the locking element (8).

Item 9. The building panels as in any one of the items 5-8, wherein the cavity (35) extends from the displacement groove (40) to the locking groove (14). 5

Item 10. The building panels as in any one of items 5-9, wherein the displacement groove (40) extends vertically above the locking groove (14). 10

Item 11. The building panels as in any one of items 5-10, wherein an upper part (8a) of the locking element (8) is located vertically below the tongue locking surface (31) of the displaceable tongue (30). 15

Item 12. The building panels as in any one of items 5-11, wherein an upper part (14a) of the locking groove (14) is located vertically below the tongue locking surface (31) of the displaceable tongue (30). 20

Item 13. The building panels as in any one of items 5-12, wherein an upper most part of the locking element is located in a lower half of an intermediate core of the first building panel. 25

Item 14. The building panels as in any one of the preceding items, wherein the tongue and the strip pressing surface (32,33) are inclined against a horizontal plane (HP) with an angle (A1) of about 25 to 75 degrees. 30

Item 15. The building panels as in any one of the preceding items, wherein the displacement groove (40) is inclined and comprises an inner part that extends downwards. 35

Item 16. The building panels as in any one of preceding items, wherein the first and the second building panel (1,1') are locked vertically by a first and a second pair of cooperating surfaces, the first pair comprises the tongue locking surface (31) and the groove locking surface (21), the second pair comprises an upper part of the strip (6') and a lower part of the edge (37) of the second panel (1'). 40 45

Item 17. The building panels as in any one of the preceding items, wherein said groove locking surface (21) and tongue locking surface (31) are inclined against a horizontal plane. 50

Item 18. The building panels as in any one of preceding items, wherein the groove locking surface (21) and the tongue locking surface are inclined with an angle (A2) of about 10 to about 60 degrees. 55

Item 19. The building panels as in any one of preceding items, wherein the displaceable tongue (30)

comprises a flexible friction element (38).

Item 20. The building panels as in any one of the preceding items, wherein the displaceable tongue (30) comprises at least two protrusions (34) extending from the main body (36), wherein each protrusion comprises said tongue pressing surface (32) at an outer part of the protrusion, wherein each tongue pressing surface is configured to be in contact during locking with a locking element provided on the strip.

Item 21. The building panels as in any one of the preceding items, wherein the building panel (1,1') is a floor panel.

Item 22. The building panels as in any one of the preceding items, wherein the upper and outer part of the displaceable tongue in an unlocked position is located in the displacement groove (40).

Item 23. The building panels as in any one of the preceding items, wherein the innermost part of the displaceable tongue (30) is below the outermost part of the displaceable tongue.

Item 24. The building panels as in any one of the preceding items, wherein the tongue pressing surface (32) is located vertically below the tongue locking surface (31) .

Item 25. The building panels as in any one of the preceding items, wherein the strip is flexible such that it bends downwards during locking.

Item 26. The building panels as in any one of the preceding items, wherein the displaceable tongue (30) is gradually inserted into the tongue groove (20) from a tongue part, which is adjacent to an installed long edge (2), to another tongue part, which is adjacent to a free long edge.

Item 27. The building panels as in item 1, wherein the strip (6) comprises a locking element (8) configured to cooperate with a downwardly open locking groove (14), formed on the second panel, for locking of the first and the second building panel (1,1') in a horizontal direction.

Item 28. The building panels as in one of the preceding items, wherein the displaceable tongue is an injection-moulded tongue.

Claims

1. Building panels provided with a locking system for vertical locking of a first (1) and a second (1') building panel by a vertical displacement of the second build-

ing panel (1') against the first building panel (1), the building panels comprising:

- a sidewardly open tongue groove (20) provided at an edge of the first building panel (1);
 a strip (6) protruding below the tongue groove (20) and outwardly beyond an upper part of the edge of said first building panel (1),
 the strip (6) comprising a locking element (8) configured to cooperate with a downwardly open locking groove (14) formed on the second building panel for locking of the first and the second building panel (1, 1') in a horizontal direction; and
 a displaceable tongue (30) provided in a sidewardly open displacement groove (40) at an edge of the second building panel, the displaceable tongue (30) comprising a main body extending along the edge of the second building panel and a tongue locking surface (31) located at an upper and outer part of the tongue, the tongue locking surface being configured to cooperate with a groove locking surface (21) of the tongue groove (20) for vertical locking, wherein the displaceable tongue comprises an inner part spaced inwardly from an upper part of the edge of said second building panel (1'), and the inner part comprises a tongue pressing surface (32) configured to cooperate with a strip pressing surface (33) on the strip (6) such that the displaceable tongue (30) is displaced into the tongue groove when the tongue pressing surface (32) and the strip pressing surface (33) are displaced vertically against each other to obtain a locking of the first and the second building panels (1, 1') in a vertical direction.
2. The building panels as claimed in claim 1, wherein said displaceable tongue (30) comprises a protrusion (34) and the second panel (1') comprises a cavity (35) for housing the protrusion.
 3. The building panels as claimed in claim 1 or 2, wherein the protrusion (34) comprises a part (39) that is flexible.
 4. The building panels as claimed in claim 3, wherein the flexible part (39) creates a pretension against the tongue groove (20).
 5. The building panels as claimed in any one of the claims 2-4, wherein the tongue pressing surface (32) is provided on the protrusion (34) and the strip pressing surface (33) is provided on the locking element (8).
 6. The building panels as claimed in claim 5, wherein the strip pressing surface (33) is provided at an inclined surface of the locking element (8) directed towards the first edge.
 7. The building panels as claimed in any one of the preceding claims, wherein the cavity (35) extends from the displacement groove (40) to the locking groove (14).
 8. The building panels as claimed in any one of the preceding claims, wherein the displacement groove (40) extends vertically above the locking groove (14).
 9. The building panels as claimed in any one of preceding claims, wherein an upper part (8a) of the locking element (8) is located vertically below the tongue locking surface (31) of the displaceable tongue (30).
 10. The building panels as claimed in any one of the preceding claims, wherein an upper most part of the locking element (8) is located in a lower half of an intermediate core of the first building panel (1).
 11. The building panels as claimed in any one of preceding claims, wherein the first and the second building panels (1, 1') are locked vertically by a first and a second pair of cooperating surfaces, the first pair comprising the tongue locking surface (31) and the groove locking surface (21), and the second pair comprising an upper part of the strip (6) and a lower part of an edge (37) of the second building panel (1').
 12. The building panels as claimed in any one of the preceding claims, wherein said groove locking surface (21) and tongue locking surface (31) are inclined against a horizontal plane.
 13. The building panels as claimed in any one of the preceding claims, wherein the displaceable tongue (30) comprises at least two protrusions (34) extending from the main body (36), each protrusion comprising said tongue pressing surface (32) at an outer part of the protrusion, wherein each tongue pressing surface is configured to be in contact during locking with the locking element (8) provided on the strip (6).
 14. The building panels as claimed in any one of the preceding claims, wherein the tongue pressing surface (32) is located vertically below the tongue locking surface (31).
 15. The building panels as claimed in any one of the preceding claims, wherein the second building panel (1') is further configured to be connected to the first building panel (1) by angling, during which angling the displaceable tongue (30) is gradually inserted into the tongue groove (20) along said edge of the first building panel (1), wherein the edges of the first (1) and second (1') building panels are short edges.

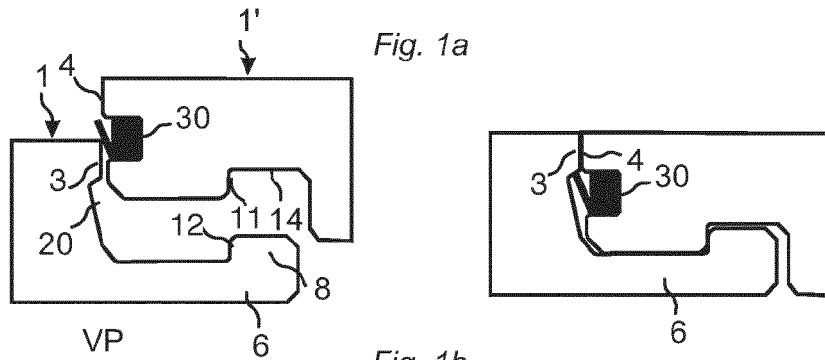

Fig. 1a

Fig. 1b

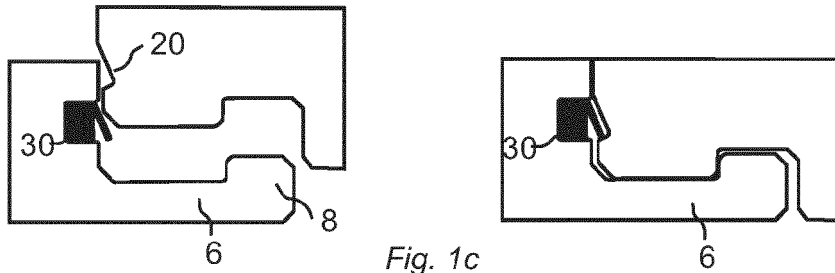

Fig. 1c

Fig. 1d

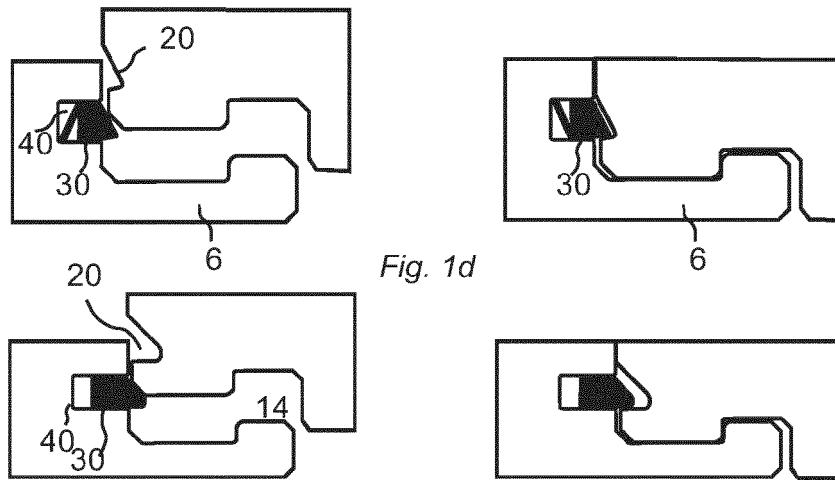
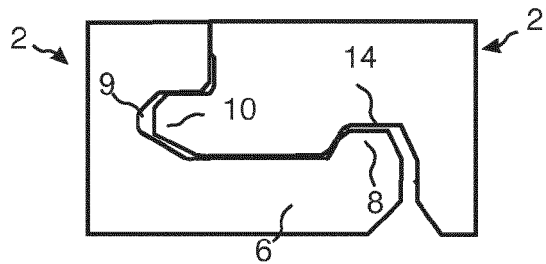

Fig. 1e

Fig. 1f



KNOWN TECHNOLOGY

Fig. 2a

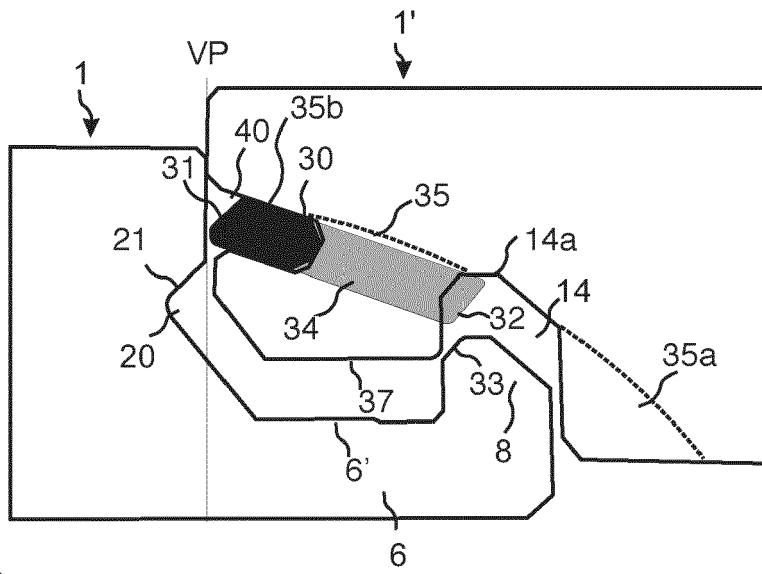

Fig. 2b

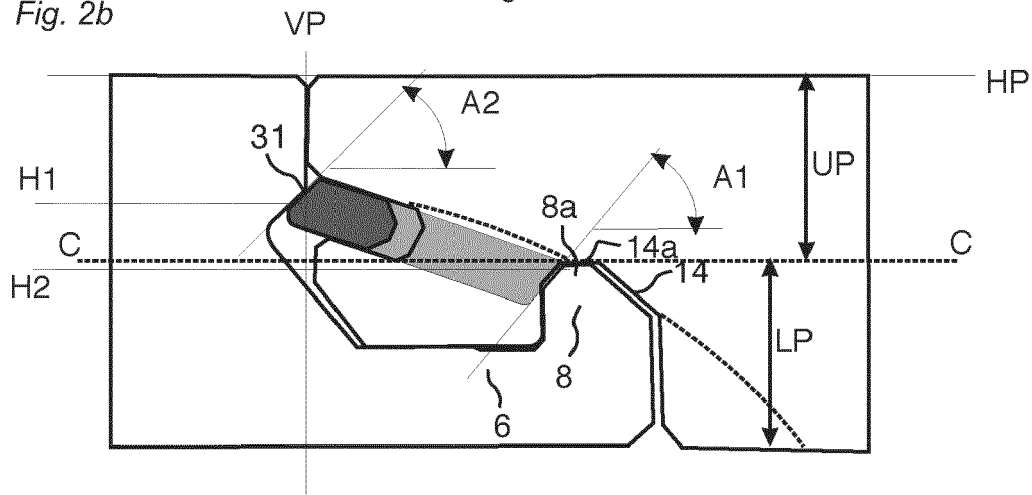

Fig. 2c

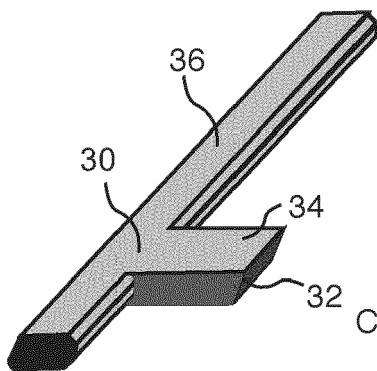

Fig. 2d

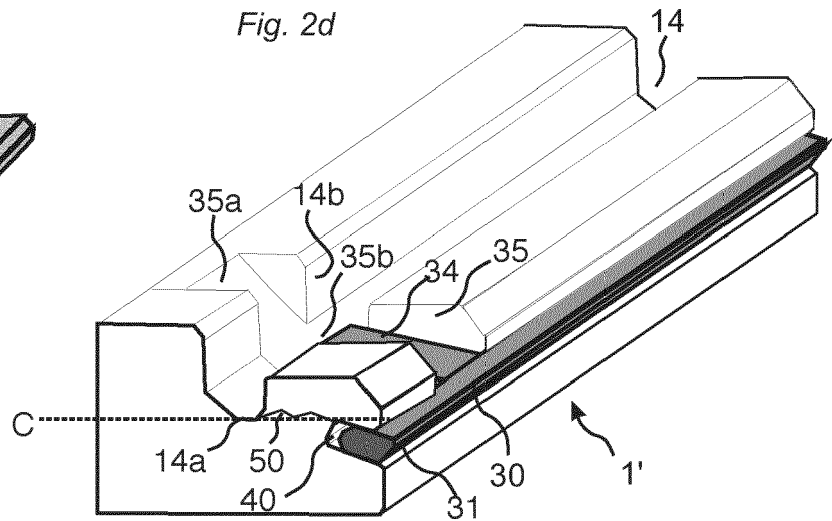

Fig. 3a

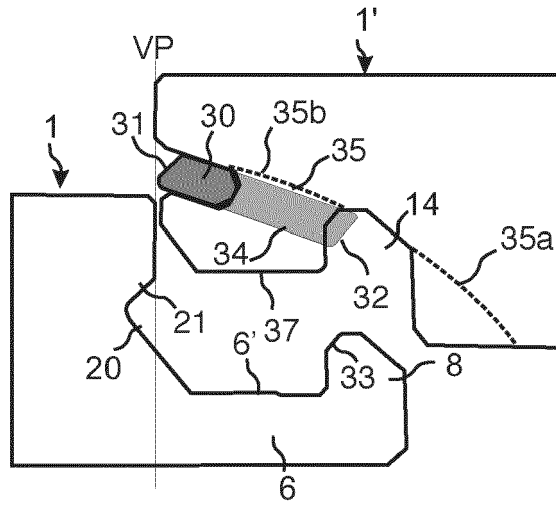

Fig. 3b

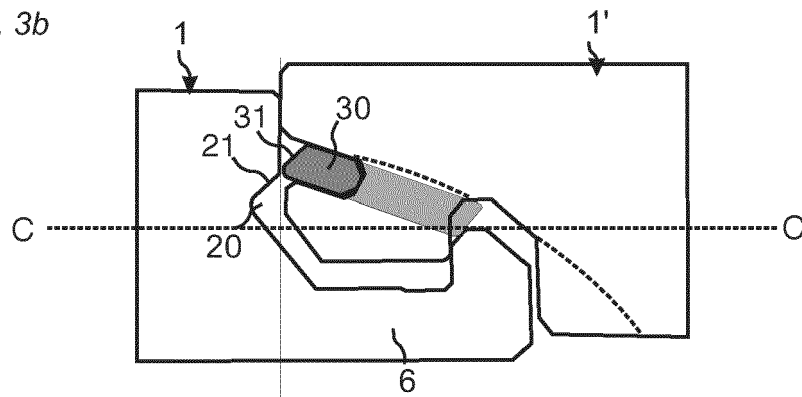

Fig. 3c

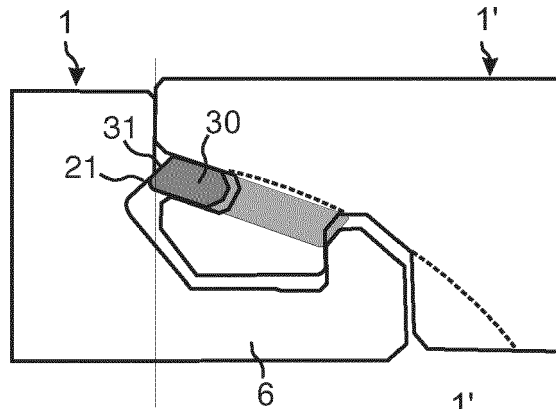

Fig. 3d

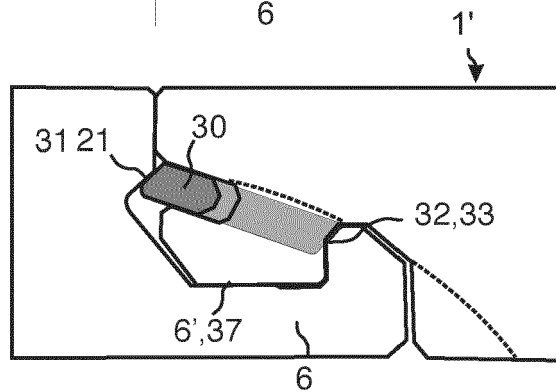

Fig. 4a

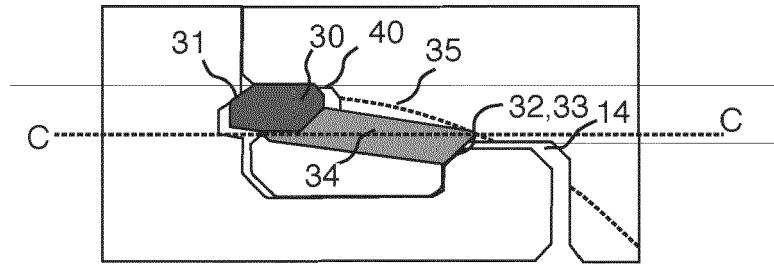

Fig. 4b

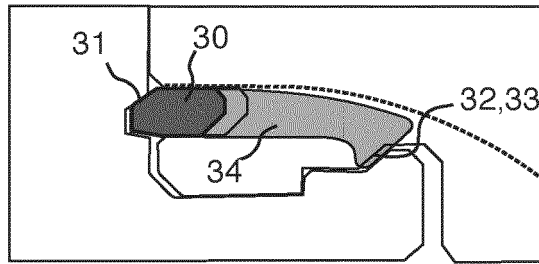

Fig. 4c

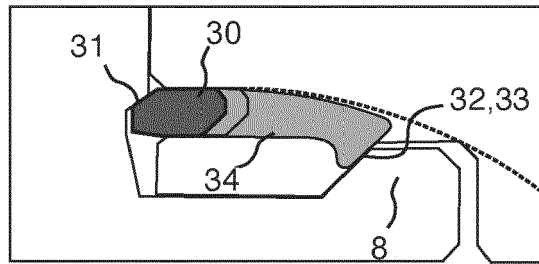

Fig. 4d

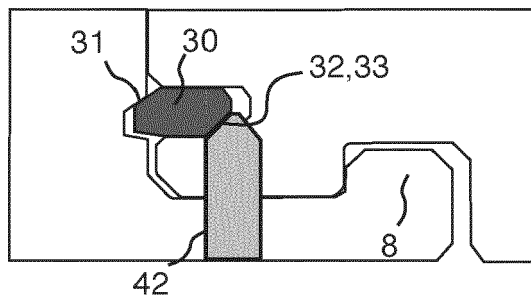
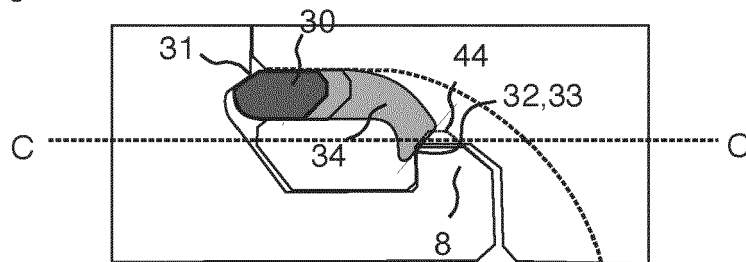

Fig. 4e



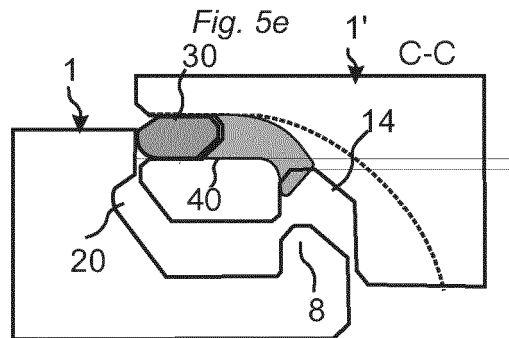
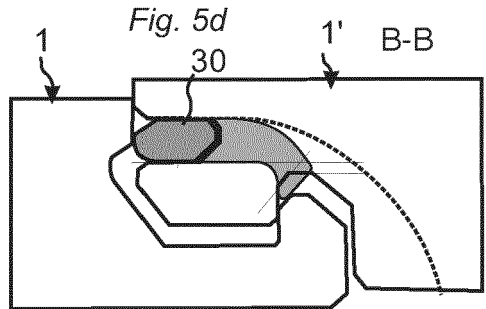
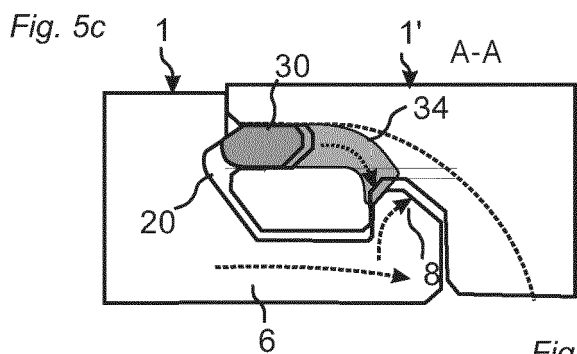
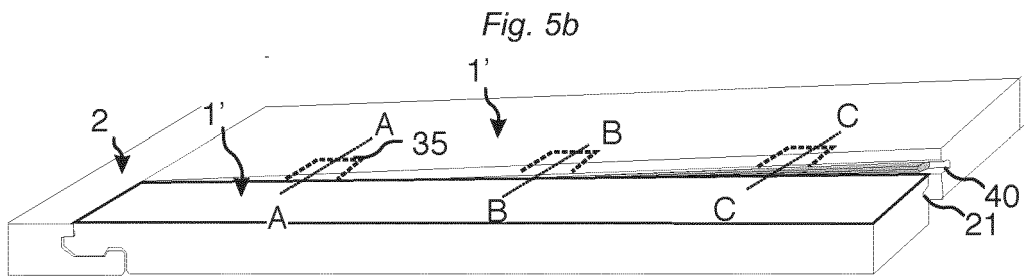
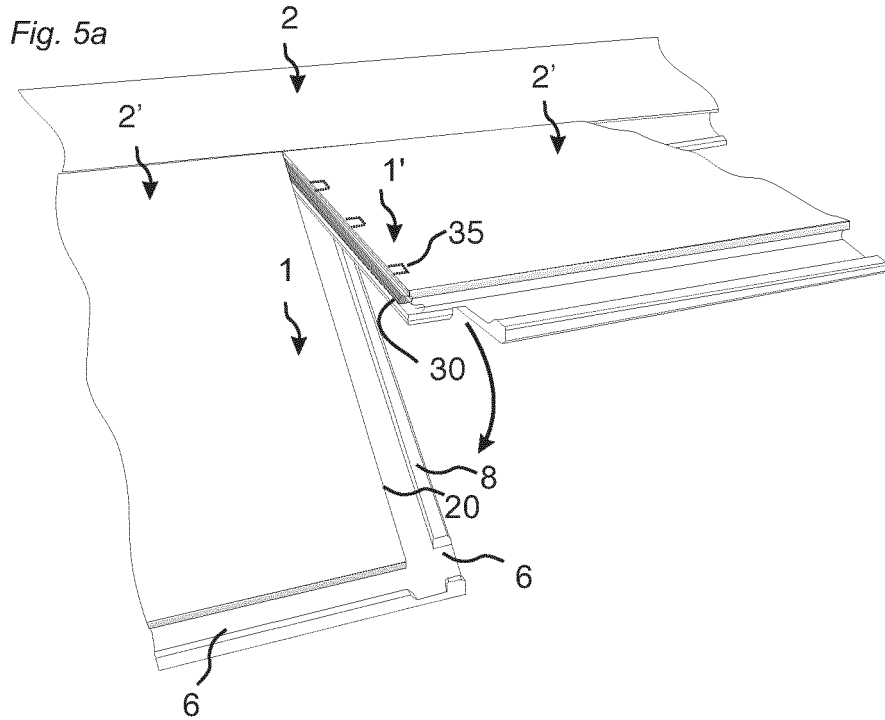

Fig. 6a

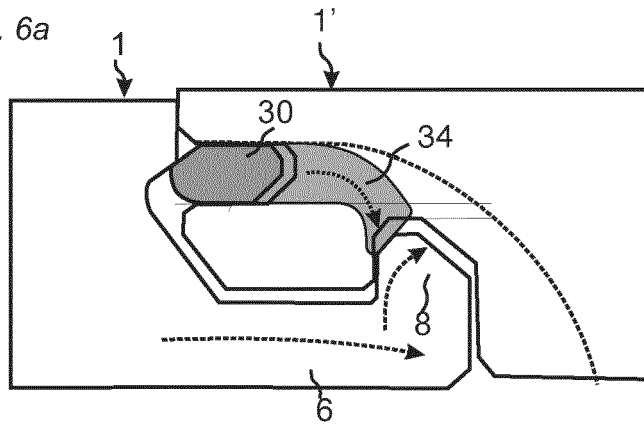

Fig. 6b

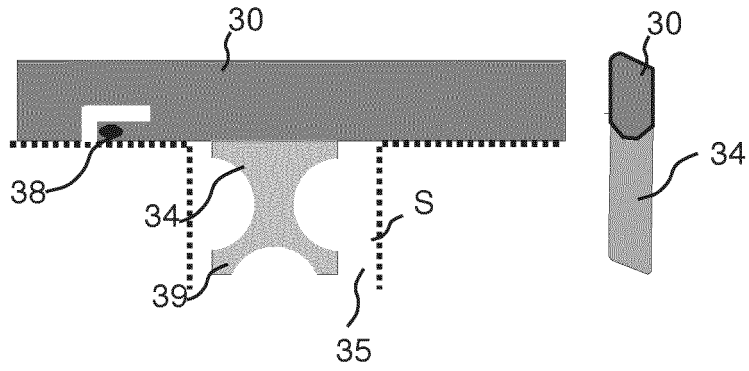

Fig. 6c

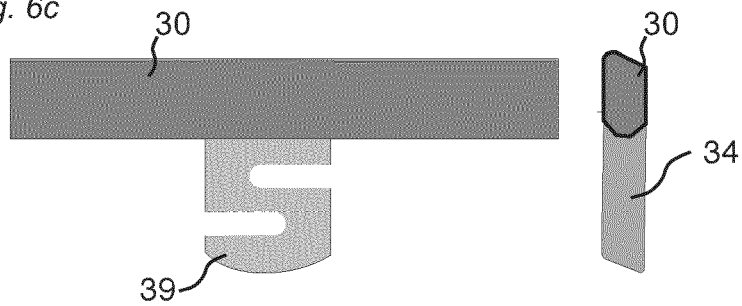

Fig. 6d

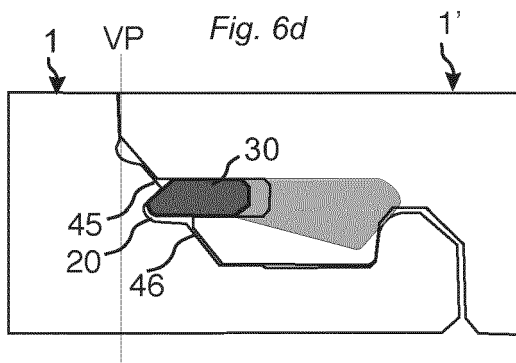

Fig. 6e

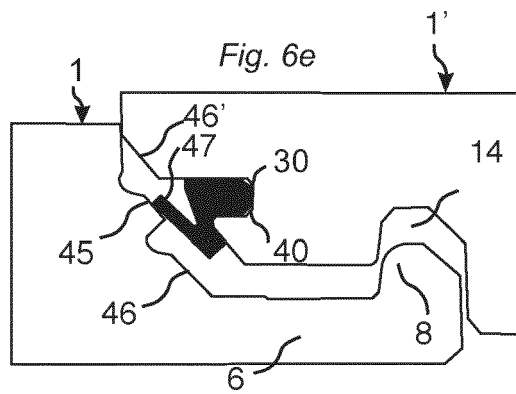

Fig. 7a

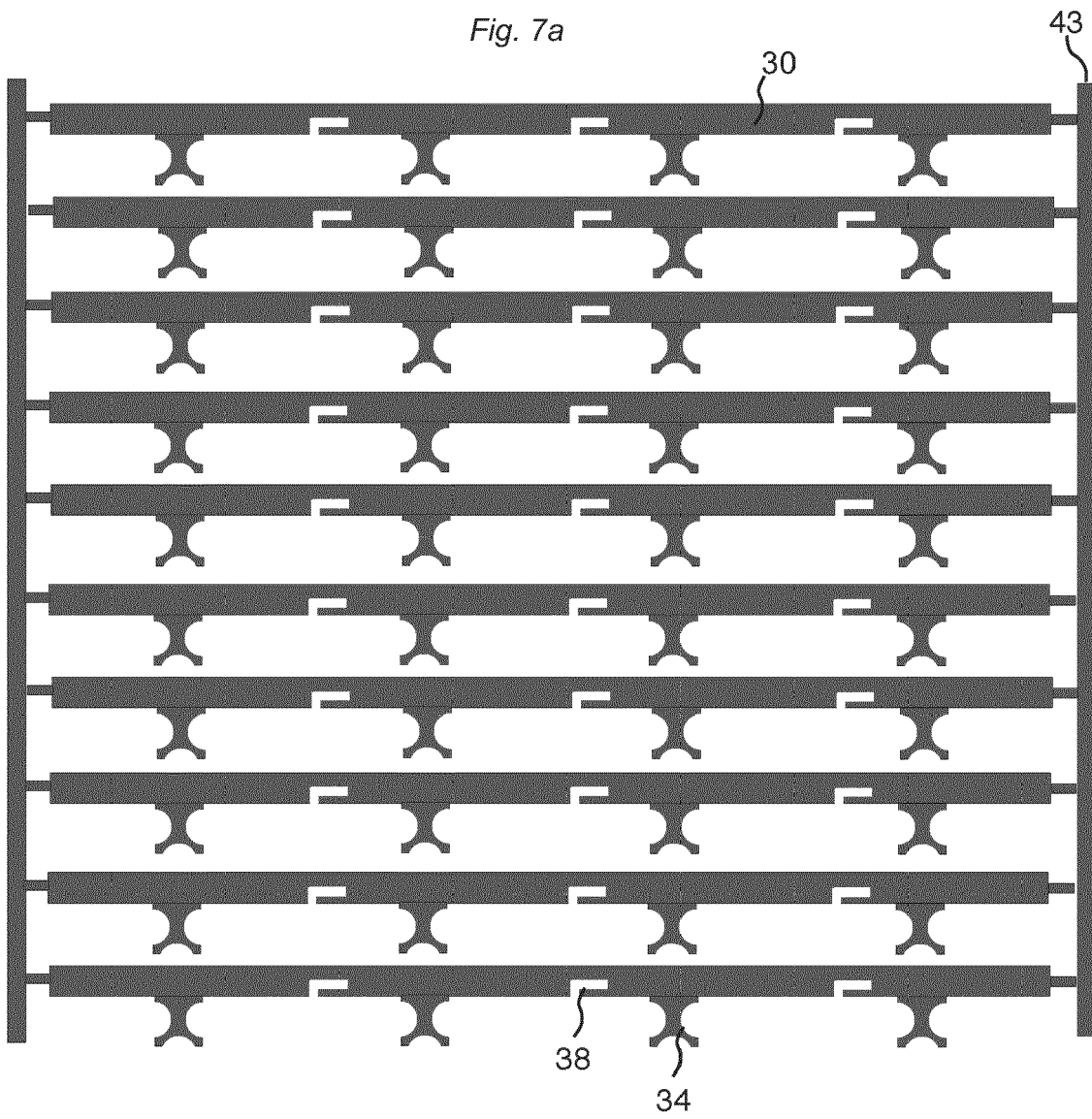
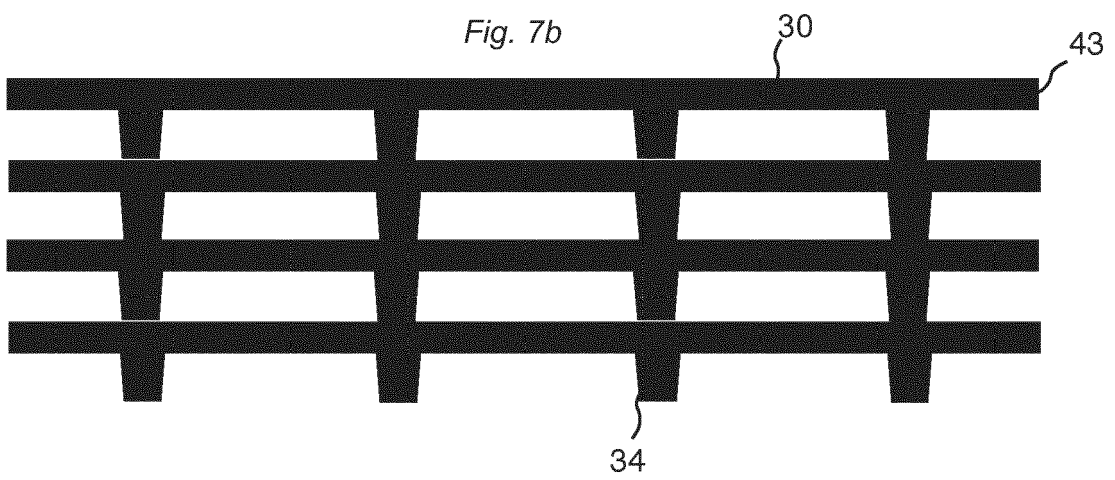

Fig. 7b





EUROPEAN SEARCH REPORT

Application Number
EP 20 19 2928

5

10

15

20

25

30

35

40

45

50

55

DOCUMENTS CONSIDERED TO BE RELEVANT			
Category	Citation of document with indication, where appropriate, of relevant passages	Relevant to claim	CLASSIFICATION OF THE APPLICATION (IPC)
A	EP 1 650 375 A1 (VAELINGE INNOVATION AB [SE]) 26 April 2006 (2006-04-26) * paragraph [0084] - paragraph [0088]; figures 6a-6c, 7 *	1-15	INV. E04F15/04 E04F15/02
Y	EP 2 270 291 A1 (FLOORING TECHNOLOGIES LTD [MT]) 5 January 2011 (2011-01-05) * paragraph [0022] - paragraph [0026]; figures 3-6 *	12	
X	WO 2011/012104 A2 (SCHULTE GUIDO [DE]; ESCHLBECK FRANZ [DE]) 3 February 2011 (2011-02-03)	1-4,7-9, 14,15	
Y	* page 11, line 21 - page 14, line 26;	10-12	
A	figures 1-6 *	5,6,13	
A	DE 10 2009 041297 A1 (SCHULTE GUIDO [DE]) 24 March 2011 (2011-03-24) * abstract; figures 1-5 *	1	
Y	WO 2007/141605 A2 (FLOORING IND LTD [IE]; CAPPELLE MARK [BE]) 13 December 2007 (2007-12-13) * abstract; figures 9, 10 *	10	TECHNICAL FIELDS SEARCHED (IPC) E04F
Y	EP 1 243 721 A2 (AKZENTA PANELEE & PROFILE GMBH [DE]) 25 September 2002 (2002-09-25) * abstract; figures 11, 12 *	11	
The present search report has been drawn up for all claims			
Place of search Munich		Date of completion of the search 1 December 2020	Examiner Khera, Daljit
CATEGORY OF CITED DOCUMENTS X : particularly relevant if taken alone Y : particularly relevant if combined with another document of the same category A : technological background O : non-written disclosure P : intermediate document		T : theory or principle underlying the invention E : earlier patent document, but published on, or after the filing date D : document cited in the application L : document cited for other reasons & : member of the same patent family, corresponding document	

EPO FORM 1503 03.82 (P04C01)

ANNEX TO THE EUROPEAN SEARCH REPORT
ON EUROPEAN PATENT APPLICATION NO.

EP 20 19 2928

5 This annex lists the patent family members relating to the patent documents cited in the above-mentioned European search report.
The members are as contained in the European Patent Office EDP file on
The European Patent Office is in no way liable for these particulars which are merely given for the purpose of information.

01-12-2020

Patent document cited in search report	Publication date	Patent family member(s)	Publication date
EP 1650375	A1	26-04-2006	AT 382113 T 15-01-2008
			AT 535660 T 15-12-2011
			AT 542967 T 15-02-2012
			AU 2005296349 A1 27-04-2006
			BR PI0516331 A 02-09-2008
			CA 2581678 A1 27-04-2006
			CN 101044289 A 26-09-2007
			CN 101684685 A 31-03-2010
			CY 1107360 T1 19-12-2012
			DE 202005021702 U1 16-07-2009
			DE 202005021864 U1 23-09-2010
			DE 202005021865 U1 30-09-2010
			DE 202005021889 U1 05-01-2011
			DE 202005022094 U1 11-07-2013
			DE 202005022095 U1 11-07-2013
			DE 202005022097 U1 16-07-2013
			DE 602004010914 T2 11-12-2008
			DK 1650375 T3 21-04-2008
			DK 1802827 T3 14-05-2012
			DK 1936068 T3 19-03-2012
			DK 2388392 T3 08-04-2019
			EP 1650375 A1 26-04-2006
			EP 1802827 A1 04-07-2007
			EP 1936068 A2 25-06-2008
			EP 2278091 A2 26-01-2011
			EP 2281972 A2 09-02-2011
			EP 2378026 A2 19-10-2011
			EP 2378027 A2 19-10-2011
			EP 2378028 A2 19-10-2011
			EP 2385186 A2 09-11-2011
			EP 2385187 A2 09-11-2011
			EP 2388116 A2 23-11-2011
			EP 2388391 A2 23-11-2011
			EP 2388392 A2 23-11-2011
			EP 2388393 A2 23-11-2011
			EP 2388394 A2 23-11-2011
			EP 2388395 A2 23-11-2011
			EP 2388396 A2 23-11-2011
			EP 2388397 A2 23-11-2011
			EP 2388398 A2 23-11-2011
			EP 2388399 A2 23-11-2011
			EP 2388400 A2 23-11-2011
			EP 2388401 A2 23-11-2011
			EP 2388402 A2 23-11-2011
			EP 2388403 A2 23-11-2011
			EP 2388404 A2 23-11-2011

EPO FORM P0459

For more details about this annex : see Official Journal of the European Patent Office, No. 12/82

55

ANNEX TO THE EUROPEAN SEARCH REPORT
ON EUROPEAN PATENT APPLICATION NO.

EP 20 19 2928

5 This annex lists the patent family members relating to the patent documents cited in the above-mentioned European search report.
The members are as contained in the European Patent Office EDP file on
The European Patent Office is in no way liable for these particulars which are merely given for the purpose of information.

01-12-2020

Patent document cited in search report	Publication date	Patent family member(s)	Publication date
		EP 2388405 A2	23-11-2011
		EP 2388409 A2	23-11-2011
		EP 2390512 A2	30-11-2011
		EP 3608486 A2	12-02-2020
15		ES 2298664 T3	16-05-2008
		ES 2378330 T3	11-04-2012
		ES 2381381 T3	25-05-2012
		ES 2708663 T3	10-04-2019
		ES 2715200 T3	03-06-2019
20		ES 2751352 T3	31-03-2020
		HU E042198 T2	28-06-2019
		HU E043159 T2	29-07-2019
		IL 182264 A	31-10-2012
		JP 4652411 B2	16-03-2011
		JP 2008518130 A	29-05-2008
25		KR 20070063046 A	18-06-2007
		LT 2388392 T	12-03-2019
		LT 2388395 T	10-10-2019
		LT 2388399 T	11-02-2019
		MY 139000 A	28-08-2009
30		NO 338585 B1	12-09-2016
		NZ 554905 A	25-09-2009
		PL 1650375 T3	31-07-2008
		PL 1802827 T3	31-07-2012
		PL 1936068 T3	31-07-2012
		PL 2281972 T3	31-03-2020
35		PL 2388116 T3	30-04-2020
		PL 2388392 T3	31-05-2019
		PL 2388395 T3	31-01-2020
		PL 2388399 T3	30-04-2019
		PL 2388401 T3	31-12-2019
40		PL 2388405 T3	31-05-2019
		PT 1650375 E	17-03-2008
		PT 1802827 E	02-05-2012
		PT 1936068 E	06-03-2012
		PT 2388392 T	25-02-2019
		PT 2388399 T	04-02-2019
45		RU 2373348 C2	20-11-2009
		SI 1650375 T1	30-06-2008
		SI 1802827 T1	31-05-2012
		SI 2388392 T1	30-08-2019
		TR 201901149 T4	21-02-2019
		TR 201901831 T4	21-03-2019
50		TR 201903132 T4	21-03-2019
		TR 201903137 T4	21-03-2019
		UA 90282 C2	26-04-2010

EPO FORM P0459

For more details about this annex : see Official Journal of the European Patent Office, No. 12/82

55

ANNEX TO THE EUROPEAN SEARCH REPORT
ON EUROPEAN PATENT APPLICATION NO.

EP 20 19 2928

5 This annex lists the patent family members relating to the patent documents cited in the above-mentioned European search report.
The members are as contained in the European Patent Office EDP file on
The European Patent Office is in no way liable for these particulars which are merely given for the purpose of information.

01-12-2020

Patent document cited in search report	Publication date	Patent family member(s)	Publication date
		US 2008134607 A1	12-06-2008
		US 2008134614 A1	12-06-2008
		US 2008295432 A1	04-12-2008
		US 2013081349 A1	04-04-2013
		US 2014053497 A1	27-02-2014
		US 2019093370 A1	28-03-2019
		WO 2006043893 A1	27-04-2006
		ZA 200704038 B	27-08-2008

EP 2270291	A1 05-01-2011	AT 510088 T	15-06-2011
		EP 2270291 A1	05-01-2011
		ES 2366820 T3	25-10-2011
		PL 2270291 T3	31-10-2011

WO 2011012104	A2 03-02-2011	BR 112012001893 A2	15-03-2016
		CN 102482886 A	30-05-2012
		DE 102009034902 A1	17-02-2011
		EP 2459818 A2	06-06-2012
		PL 2459818 T3	31-10-2018
		US 2012124932 A1	24-05-2012
		WO 2011012104 A2	03-02-2011

DE 102009041297	A1 24-03-2011	CN 102498251 A	13-06-2012
		DE 102009041297 A1	24-03-2011
		EP 2478168 A2	25-07-2012
		US 2012174521 A1	12-07-2012
		WO 2011032540 A2	24-03-2011

WO 2007141605	A2 13-12-2007	BE 1017157 A3	04-03-2008
		CA 2652722 A1	13-12-2007
		CA 2856920 A1	13-12-2007
		CA 2937782 A1	13-12-2007
		CA 2937817 A1	13-12-2007
		CN 101460688 A	17-06-2009
		CN 104074334 A	01-10-2014
		CN 104563443 A	29-04-2015
		DE 202007018935 U1	22-10-2009
		DK 2029831 T3	26-10-2015
		EP 2029831 A2	04-03-2009
		EP 2843155 A1	04-03-2015
		EP 3239434 A1	01-11-2017
		EP 3663481 A2	10-06-2020
		EP 3663482 A2	10-06-2020
		EP 3680421 A2	15-07-2020
		ES 2550588 T3	10-11-2015
		ES 2632962 T3	18-09-2017

EPO FORM P0459

For more details about this annex : see Official Journal of the European Patent Office, No. 12/82

55

ANNEX TO THE EUROPEAN SEARCH REPORT
ON EUROPEAN PATENT APPLICATION NO.

EP 20 19 2928

5 This annex lists the patent family members relating to the patent documents cited in the above-mentioned European search report.
The members are as contained in the European Patent Office EDP file on
The European Patent Office is in no way liable for these particulars which are merely given for the purpose of information.

01-12-2020

Patent document cited in search report	Publication date	Patent family member(s)	Publication date
		HU E025971 T2	30-05-2016
		PL 2029831 T3	31-12-2015
		PL 2843155 T3	31-10-2017
		PT 2029831 E	12-11-2015
		RU 2008152007 A	20-07-2010
		US 2009193741 A1	06-08-2009
		US 2014033636 A1	06-02-2014
		US 2015204080 A1	23-07-2015
		US 2015204081 A1	23-07-2015
		US 2016251861 A1	01-09-2016
		US 2017051514 A1	23-02-2017
		US 2017284106 A1	05-10-2017
		US 2018127985 A1	10-05-2018
		US 2019048595 A1	14-02-2019
		US 2019330858 A1	31-10-2019
		US 2020063444 A1	27-02-2020
		US 2020270875 A1	27-08-2020
		US 2020270876 A1	27-08-2020
		WO 2007141605 A2	13-12-2007

EP 1243721	A2	25-09-2002	
		AT 222634 T	15-09-2002
		AT 277246 T	15-10-2004
		AU 1546600 A	22-01-2001
		AU 1546800 A	22-01-2001
		CA 2377799 A1	11-01-2001
		CA 2377919 A1	11-01-2001
		EP 1165906 A1	02-01-2002
		EP 1190149 A1	27-03-2002
		EP 1243721 A2	25-09-2002
		EP 2116666 A1	11-11-2009
		EP 2312087 A2	20-04-2011
		ES 2182582 T3	01-03-2003
		ES 2228133 T3	01-04-2005
		PT 1190149 E	31-01-2005
		RU 2224070 C2	20-02-2004
		US 6505452 B1	14-01-2003
		US 7896571 B1	01-03-2011
		WO 0102669 A1	11-01-2001
		WO 0102670 A1	11-01-2001

EPO FORM P0459

For more details about this annex : see Official Journal of the European Patent Office, No. 12/82

REFERENCES CITED IN THE DESCRIPTION

This list of references cited by the applicant is for the reader's convenience only. It does not form part of the European patent document. Even though great care has been taken in compiling the references, errors or omissions cannot be excluded and the EPO disclaims all liability in this regard.

Patent documents cited in the description

- WO 2006043893 A [0014]