



(11) **EP 3 764 005 B1**

(12) **EUROPEAN PATENT SPECIFICATION**

(45) Date of publication and mention of the grant of the patent:
19.01.2022 Bulletin 2022/03

(51) International Patent Classification (IPC):
F24F 7/02^(2006.01)

(21) Application number: **19185668.1**

(52) Cooperative Patent Classification (CPC):
F24F 7/025

(22) Date of filing: **11.07.2019**

(54) **DEVICE WITH A ROOF TURBOFAN FOR EXTRACTING THE AIR FROM A BUILDING HAVING AN AIR TANK WITH A TURBOFAN THEREOF AND METHOD OF BUILDING VENTILATION WITH SUCH DEVICE**

VORRICHTUNG MIT EINEM DACHTURBOLÜFTER ZUR ABSAUGUNG DER LUFT AUS EINEM GEBÄUDE MIT EINEM LUFTBEHÄLTER MIT EINEM TURBOLÜFTER UND VERFAHREN ZUR GEBÄUDEBELÜFTUNG MIT SOLCH EINER VORRICHTUNG

DISPOSITIF COMPORTANT UNE TURBOSOUFFLANTE DE TOIT POUR EXTRAIRE L'AIR D'UN BÂTIMENT AYANT UN RÉSERVOIR D'AIR COMPORTANT UNE TURBOSOUFFLANTE ET PROCÉDÉ DE VENTILATION D'UN BÂTIMENT COMPORTANT UN TEL DISPOSITIF

(84) Designated Contracting States:
AL AT BE BG CH CY CZ DE DK EE ES FI FR GB GR HR HU IE IS IT LI LT LU LV MC MK MT NL NO PL PT RO RS SE SI SK SM TR

(30) Priority: **10.07.2019 LT 2019518**

(43) Date of publication of application:
13.01.2021 Bulletin 2021/02

(73) Proprietor: **Vilnius Gediminas Technical University**
10223 Vilnius (LT)

(72) Inventors:
• **Martinaitis, Vytautas**
10223 Vilnius (LT)

- **Bielskus, Juozas**
10223 Vilnius (LT)
- **Motuzienė, Violeta**
10223 Vilnius (LT)
- **Streckienė, Giedrė**
10223 Vilnius (LT)
- **Rimdzius, Dovydas**
10223 Vilnius (LT)

(74) Representative: **Zaboliene, Reda**
Metida
Business center Vertas
Gyneju str. 16
01109 Vilnius (LT)

(56) References cited:
DE-A1-102004 052 223 **LT-B- 6 613**
US-A- 4 043 777 **US-B1- 6 302 778**

EP 3 764 005 B1

Note: Within nine months of the publication of the mention of the grant of the European patent in the European Patent Bulletin, any person may give notice to the European Patent Office of opposition to that patent, in accordance with the Implementing Regulations. Notice of opposition shall not be deemed to have been filed until the opposition fee has been paid. (Art. 99(1) European Patent Convention).

Description

FIELD OF THE INVENTION

[0001] The invention relates to a field of devices for ventilation, and in particular, a device with a roof turbofan and an air tank with a turbofan thereof to increase the functionality of a roof turbofan.

THE RELATED ART

[0002] The present invention provides a device for ventilation with increased functionality with a roof turbofan that can ensure the required air exchange inside the building and even when the wind does not rotate the roof turbofan sufficiently or completely due to the reduced speed.

[0003] A new device with increased functionality for extracting the air from a building with a roof turbofan, an isobaric tank of variable volume and a turbofan thereof additionally has an axis and a clutch of the roof turbofan through which a torque of the roof turbofan rotated by the wind is transmitted to a multi-stage gear transmission. When the gear transmission is actuated, a cable / wire is driven on an output axis through a pulley to lift an isobaric air tank weight of variable volume and the air is sucked through an air intake valve to fill the air tank. When the maximum volume of the air tank is reached, the air suction is stopped, the valve closes due to its weight, the isobaric air storage tank weight is released to fall freely, so that the compressed air in the air tank starts supplying the air to the compressed air driven turbofan which rotates and extracts the air from the room because of compressed air, thus ensuring ventilation of the room in the absence of the wind and when the roof turbofan does not rotate.

[0004] This technical solution does not require external energy, the structure is simple, the solution is easy to implement.

[0005] Document LT 6613 B (published on 10 April 2019) provides a technical solution where the said roof turbofan ensures ventilation of the air of the room in the absence of the wind, using an air tank of constant volume (isochoric) or of constant pressure (isobaric). The cited document provides a solution where the use of a reversible compressor results in a limited ability to achieve the required pressure and a low operating efficiency when operating in a reverse manner. There is no technical solution for ensuring the required ventilation without a reverse compressor when the wind does not rotate the roof turbofan sufficiently or completely due to its reduced speed.

[0006] The cited solution of the related art is characterized by the following deficiencies:

- The required pressure in the air tank is not reached and the potential of having the required pressure in the air tank is limited;

- Inefficient operation is avoided by rotating the roof turbofan with a reverse compressor (rotation of the roof turbofan using a compressor is inefficient);
- An inefficient system for transferring energy to the air tank will result in higher losses for the air tank.

[0007] This invention provides a technical solution that does not have the above deficiencies.

10 SUMMARY OF THE INVENTION

[0008] This invention provides a technical solution - a structure of a device with a roof turbofan and an air tank and a turbofan thereof to increase the functionality of the roof turbofan, i. e. allowing the air exchange inside the building for a certain period when the wind does not rotate the roof turbofan. The structure of the present invention comprises at least the following elements: a roof turbofan, an axis, which can be connected through a clutch to a multi-stage gear transmission which is connected to an isobaric air tank weight of variable volume through a cable passing through a pulley. If the air change created by the turbofan rotated by the wind inside the building is higher than required at the time, the turbofan is connected through the clutch to the multi-stage gear transmission that is activated and starts lifting the isobaric air tank weight, thus increasing the volume of the air tank to its maximum possible volume. When the air tank is filled with the air, the air can be released at a time when the wind does not rotate the roof turbofan sufficiently or completely, and the building does not achieve the required air exchange and proper ventilation. The air is released from the air tank when the isobaric air tank weight is released to fall freely, the compressed air is released through the compressed air driven turbofan, which sucks the air from the building, thereby ensuring the air circulation inside the building.

[0009] The present invention with a roof turbofan and an compressed air driven turbofan ensures the required air exchange, ventilation for a certain period when the wind does not rotate the roof turbofan sufficiently or completely due to its reduced speed. The present invention does not require an external power source and does not use expensive, short-lived batteries.

45 BRIEF DESCRIPTION OF DRAWINGS

[0010] Figure 1 depicts a schematic, principal view of a structure of a device with an isobaric air tank presented herein.

[0011] Description of numbers marked in the figure:

- 1 - isobaric air storage tank of variable volume;
- 2 - roof turbofan;
- 3 - axis, shaft connecting a turbofan and a clutch;
- 4 - clutch;
- 5 - multi-stage gear transmission;
- 6 - building, room;

- 7 - air intake openings of the building;
- 8 - isobaric air tank weight;
- 9 - pulley;
- 10 - compressed air driven turbofan;
- 11 - air outlet;
- 12 - cable;
- 13 - air exhaust pipe;
- 14 - air intake valve.

[0012] The presented figure is more illustrative, scale, proportions and other aspects do not necessarily correspond to a real technical solution.

THE PREFERRED EMBODIMENTS

[0013] A roof turbofan mounted on the roof of the building and connected to openings through which the air is extracted from the building is rotated by the wind. When the wind rotates the roof turbofan, it extracts the air from the building through the air outlet opening. When the air is extracted from the building by the roof turbofan, the pressure inside the building decreases, thereby the air intake through the air inlet openings, for example, open windows, doors, leaks of the building, dedicated air inlet openings, etc., increases. In this way, the air exchange is created inside the building, the required level of ventilation is maintained. When the wind does not rotate the turbofan sufficiently or completely, the air is not extracted from the building or is extracted insufficiently, the air exchange decreases, the building is ventilated insufficiently, or it is not ventilated at all. Usually, the roof turbofan is not connected to any external power sources, so if the wind does not rotate the turbofan properly, the air exchange inside the building decreases, the amount of ventilated air decreases and the air quality inside the building deteriorates. The present invention solves a technical problem by at least temporarily ensuring an increase in the air exchange of the roof turbofan inside the building when the wind does not rotate the turbofan sufficiently or completely due to its reduced speed.

[0014] In the present invention, a multi-stage gear transmission is used. The main purpose of this gear transmission is to convert a high speed and a low torque of the roof turbofan into a low speed and a high torque to lift the isobaric air tank weight. This device not only converts the speed and force but also it lifts the isobaric air tank weight and, when necessary, releases the isobaric air tank weight to fall freely.

[0015] The present invention provides a new device with increased functionality with a roof turbofan (2), an isobaric air storage tank (1) of variable volume with an compressed air driven turbofan (10), which ensures the greater air exchange when the wind does not rotate the roof turbofan (2) sufficiently or completely due to its reduced speed (Figure 1). The device with increased functionality comprises at least the following components (Figure 1):

- the roof turbofan (2) which extracts the air from the building (6) when it is rotated by the wind,
- the shaft (3) connecting the roof turbofan (2) and the clutch (4),
- 5 - the clutch (4) connected to the multi-stage gear transmission (5),
- the multi-stage gear transmission (5) which is connected by the cable (12) passing through the pulley (9) to the isobaric air tank weight (8) and, if necessary, lifts the isobaric air tank weight (8) upwards until the maximum volume of the air storage tank (1) is reached,
- the pulley (9) through which the cable (12) connecting the multi-stage gear transmission (5) to the isobaric air tank weight (8) passes;
- 15 - the isobaric air tank weight (8) which is lifted by the cable (12) when the roof turbofan (2) is driven by the wind and in the absence of wind the isobaric air tank weight (8) is released to fall and compresses the air in the air storage tank (1),
- the air storage tank (1) where the air is accumulated through the air intake valve (14) and, if necessary, when the wind does not rotate the roof turbofan (2), the air from the air storage tank (1) is released through the compressed air driven turbofan (10),
- 25 - the air tank intake valve (14) through which the air is sucked from the environment to the air storage tank (1) when the isobaric air tank weight (8) is lifted. The air can be sucked into the air storage tank (1) from the room where the air storage tank (1) is, from another room or from the outside by using a nozzle which is tightly connected to the air storage tank (1) and the air intake valve (14) is mounted at its other end,
- 35 - the compressed air driven turbofan (10) through which the compressed air coming out of the air storage tank (1) sucks the air from the building (6) and releases it through the air outlet (11),
- the air outlet (11) through which the air is released to the outside,
- 40 - the cable (12) passing through the pulley (9) and attached to the isobaric air tank weight (8);
- the exhaust pipe (13), its one end is tightly connected to the air storage tank (1) and the other end is connected to the air outlet (11) or the compressed air driven turbofan (10) adjacent thereto;
- 45 - other components.

[0016] In the present invention, the air storage tank (1) is designed to store and release the energy when the energy is accumulated in the form of compressed air. The air storage tank (1) can be installed both inside and outside the building. In the present invention, the air storage tank (1) is a volume of air surrounded by a certain mechanically rigid material, having two holes, openings or other structural solution for air inlet and outlet. The air storage tank (1) may be made of mechanically rigid materials capable of withstanding the given air pressure,

such as various metals, plastics, or other materials having similar physical, chemical properties. The most important requirement for the material of the air storage tank (1) is that the material must be air-proof and water-proof. The structure of the air storage tank (1) must also ensure the complete leak-tightness of the air storage tank (1). In the present invention, the air storage tank (1) of constant pressure, variable volume (isobaric) is used. The air storage tank (1) is capable of varying its volume at a given internal air pressure. In the present invention, the most commonly used structure is whereby the side walls of the air storage tank (1) can deform, change the shape without losing its tightness. The air storage tank (1) has a structural element for creating the air pressure inside the air storage tank (1): an isobaric air tank weight (8) of a certain weight is placed on the upper part of the air storage tank (1), which creates the internal air pressure in the air storage tank (1). In a particular case, walls of the air storage tank (1) may be flexible and the air storage tank (1) itself may be placed underwater, in which case the internal pressure in the air storage tank (1) is created by the water surrounding the air storage tank (1). Usually one roof turbofan (2) is connected to one air storage tank (1) but more than one roof turbofan (2) can be connected to one air storage tank (1).

[0017] The roof turbofan (2) is a device designed to extract the air from the building (6). The roof turbofan (2) does not require an external power source, the roof turbofan (2) is powered by the wind. The amount of the air extracted by the roof turbofan (2) depends on the energy supplied by the wind to the roof turbofan (2). Usually, the roof turbofan (2) is placed on the roof of the building (6) but in other cases it can also be placed elsewhere on the outside of the building (6). The roof turbofan (2) is connected to the air outlet or other structural element that communicates with the air inside the building (6), i. e. capable of extracting the air from the building (6). As usual, the roof turbofan (2) is not rigidly mechanically connected to other elements of the building, the roof turbofan (2) is attached to the air outlet so that it can rotate freely about its axis of rotation. In the present invention, the shaft (3) is attached to the axis of rotation of the roof turbofan (2) around which the roof turbofan (2) rotates.

[0018] In the present invention, the axis, shaft (3) is an elongated element made of a mechanically rigid material, such as metal, plastic, or other material having similar physical properties. The length of the shaft (3) may be selected with respect to the structure of the device of the present invention with increased functionality with the roof turbofan, features of the building (6), and other aspects. The roof turbofan (2) has one shaft (3). The purpose of the shaft is to connect the roof turbofan (2) and the clutch (4). The shaft (3) mechanically connects the roof turbofan (2) and the clutch (4).

[0019] The clutch (4), connection mechanism is attached to the other end of the shaft (3), than the roof turbofan (2). The clutch (4) in the whole structure of the present invention is for connecting or disconnecting the

shaft (3) of the roof turbofan (2) to the multi-stage gear transmission (5). In the present invention, the clutch (4) is a mechanical or electromechanical device. As mentioned, one axis of the clutch (4) is attached to the roof turbofan (2) and the other axis is attached to the multi-stage gear transmission (5). In addition to the aforesaid axes, the clutch (4) has a controlling element which connects or disconnects different axes of the clutch (4). The said controlling mechanism may be mechanical, i. e. the clutch (4) is connected or disconnected under mechanical force (e. g. ratio of gravity and centrifugal force). In another embodiment of the present invention, the controlling element of the clutch (4) may be electromechanical, i. e. the clutch (4) disconnects or connects axes depending on the electrical signal that controls the operation of the clutch (4). The said controlling electrical signal is transmitted to the control mechanism of the clutch (4) from the ventilation system of the building or from other systems determining the need for ventilation inside the building.

[0020] The clutch (4) mechanically connects or disconnects the roof turbofan (2) to the multi-stage gear transmission (5). The mechanism of the multi-stage gear transmission (5) is connected to the isobaric air tank weight (8) through the cable (12) and the pulley (9), which is attached to the ceiling of the building (6) or another element above the tank.

[0021] In the present invention, the multi-stage gear transmission (5), incoming transmission shaft attached to the clutch (4) that transmits the generated speed and force from the roof turbofan (2) to the multi-stage gear transmission (5) is used. The transmission (5) converts a high speed and a low torque generated by the roof turbofan (2) on the output axis of the transmission (5) into a low speed and a high torque. This energy conversion is done using a gear system. An element on which the cable (12) is driven (this element is an integral part of the transmission) is mounted on the output of the transmission (5). When the transmission (5) drives the cable (12) on the output, it lifts the isobaric air tank weight (8) of the air storage tank (1) and also increases the volume of the air storage tank (1). When the volume of the air storage tank (1) is increased, the air intake valve (14) opens in the air storage tank (1). The air intake valve (14) is a device through which room air enters the air storage tank (1). When the isobaric air tank weight (8) of the air storage tank (1) is lifted to the desired height (depends on the default settings), the clutch (4) is disconnected and the multi-stage gear transmission (5) stops lifting the isobaric air tank weight (8), the air intake valve (14) closes due to its weight. When there is insufficient ventilation in the building (6), the the isobaric air tank weight (8) is released to fall freely, thereby reducing the volume of the air storage tank (1) and compressing the air which is directed through the air exhaust pipe (13) to the compressed air driven turbofan (10). The compressed air rotates the compressed air driven turbofan (10), which starts to release the air from the building (6). This acti-

vates the air exchange in the building (6). When the the isobaric air tank weight (8) reaches its lowest position the compressed air driven turbofan (10) stops.

[0022] The pulley (9) is a device consisting of a part fixedly attached to another object and a circular movable part rotating about its axis which is connected to the fixed part of the pulley (9). The cable (12) which is pulled to one side or the other by rotating the circular movable part around its axis is on the outside of the circular movable part of the pulley (9). The pulley (9) connects the multi-stage gear transmission (5) through the cable (12) to the isobaric air tank weight (8). The pulley (9) is attached to the ceiling of the room or building (6). The pulley (9) can be made of various materials (metal, wood, plastic, etc.) which provide the pulley (9) with rigidity and allow the cable (12) to be driven around the pulley (9).

[0023] The cable (12) is a wire, rope, synthetic cable or other flexible and rigid natural or synthetic material, one end of which is attached to the multi-stage gear transmission (5) and the other end is attached to the isobaric air tank weight (8). The pulley (8) is between the multi-stage gear transmission (5) and the isobaric air tank weight (8), the cable (12) is connected to the circular movable part of the pulley (9). In this way, when the isobaric air tank weight (8) rises or descends, the circular movable part of the pulley (9) rotates about its axis, the cable (12) is pulled up or down, thereby transmitting the movement of the isobaric air tank weight (8) to the multi-stage gear transmission (5).

[0024] The air intake valve (14) is a device for introducing room air into the air storage tank (1). The air intake valve (14) can supply the air of the room (6) where the air storage tank (1) is installed. The air can also enter the air storage tank (1) from another environment (from other room or outside). When the air intake valve (14) is installed outside the room (6), the air intake valve (14) is connected to the air storage tank (1) through a pipe. The pipe can be made of different materials (glass, plastic, rubber, metal, etc.). When the air tank weight (8) is lifted, the pressure in the air storage tank (1) falls below the atmospheric pressure, therefore the air intake valve (14) opens. When the maximum volume of the air storage tank (1) is reached and the pressure in the air storage tank (1) equals the ambient air where the inlet valve (14) is, the air inlet valve (14) closes due to its weight. The air intake valve (14) is closed when the air is released from the air storage tank (1) through the air exhaust pipe (13).

[0025] The compressed air driven turbofan (10) is a device having a fixed part which is attached to the building (6) and a rotatable part which does not rotate when there is no airflow and starts to operate when the compressed air enters into it. One end of the compressed air driven turbofan (10) is connected to the air exhaust pipe (13) and the other end is connected to the air outlet (11). The compressed air driven turbofan (10) does not require electricity to operate. The compressed air driven turbofan (10) is actuated when the isobaric air tank weight (8) falls down and the compressed air enters the compressed air

driven turbofan (10) through the pipe connecting the air storage tank (1) to the compressed air driven turbofan (10). When the compressed air driven turbofan (10) is activated, the air (6) is released from the building (6) through the air outlet (11).

[0026] The air outlet (11) is an opening in the roof of the building (6), a hole having walls and a cover through which the air from the inside of the building (6) is released to the outside.

[0027] The air exhaust pipe (13) is a hollow element connecting the air storage tank (1) to the compressed air driven turbofan (10). The exhaust pipe (13) can be made of various materials (metal, plastic, etc.) and must be air-proof. The air is supplied through the air exhaust pipe (13) from the air storage tank (1) to the compressed air driven turbofan (10). The exhaust pipe (13) is tightly connected to the air storage tank (1) and its other end is directed to the compressed air driven turbofan (10) in the air outlet (11) or near to it.

[0028] The air enters the building (6) through the air intake openings (7) of the building and is released through the compressed air driven turbofan (10) having the air outlet (11) and through the roof turbofan (2). Thus, in the present invention, the device has two turbofans: through which the air is released from the building. The air is released through the roof turbofan (2) when the wind blows, and the air is released through the compressed air driven turbofan (10) when the wind does not blow. The air intake openings (7) of the building can be open or leaking windows, doors, cracks due to the leak in the structure of the building, specially installed air supply ducts, etc.

[0029] The device may also have other elements required to perform its function.

[0030] When the wind rotates the roof turbofan (2), the roof turbofan (2) reduces the air pressure inside the building (6), extracts the air from the building (6), thereby intensifying the air exchange and improving ventilation inside the building (6). As the roof turbofan (2) extracts the air from the building (6), the air from the outside of the building (6) enters the building (6) through the air intake openings (7) of the building. If the roof turbofan (2) rotates faster than necessary to achieve the appropriate air exchange, the torque of the roof turbofan (2) is transmitted to the multi-stage gear transmission (5) through the shaft (3) and clutch (4). When the multi-stage gear transmission (5) is actuated, the cable (12) is driven on the output axis of the shaft (3) to lift the isobaric air tank weight (8). When the air tank weight (8) is lifted into the air storage tank (1), the air is sucked through the air inlet valve (14) until the maximum volume of the air storage tank (1) is reached. In this way, the air tank accumulates the potential energy. When the wind does not rotate the roof turbofan (2) sufficiently or completely due to the reduced speed and the building (6) requires the air exchange, the isobaric air tank weight (8) is released to fall. When the isobaric air tank weight (8) falls down, it compresses the air in the air storage tank (1) and the air is released

through the compressed air driven turbofan (10) and the air outlet (11). The air coming out of the air storage tank (1) sucks the air, thereby ensuring the air exchange in the building (6).

[0031] The method of operation of the device described above has the following steps (Fig. 1):

- the wind rotates the roof turbofan (2);
- the roof turbofan (2) extracts the air from the building (6) to the outside;
- the fresh air enters the building (6) through air intake openings (7) of the building;
- when the roof turbofan (2) starts rotating faster than required to provide the required ventilation, the torque of the roof turbofan (2) is transmitted to the multi-stage gear transmission (5) through the shaft (3) and clutch (4);
- the multi-stage gear transmission (5) converts from a high speed and a low torque to a low speed and a high torque, which allows the isobaric air tank weight (8) to be lifted;
- when the isobaric air tank weight (8) is lifted to the maximum (as planned in the structure), the air storage tank (1) is filled with the air through the air intake valve (14);
- the clutch (4) disconnects the shaft (3) from the multi-stage gear transmission (5);

the isobaric air tank weight (8) is released to fall;

- when the air tank weight (8) falls, it compresses the air in the air storage tank (1);
- the air being compressed enters the compressed air driven turbofan (10) through the air exhaust pipe (13) and starts rotating;
- rotating compressed air driven turbofan (10) sucks the air from the building (6) which is released through the air outlet (11);
- when the isobaric air tank weight (8) reaches the lowest position, the compressed air driven turbofan (10) stops operating.

[0032] In order to illustrate and describe the invention, the description of the preferred embodiments is presented above. This is not a detailed or restrictive description to determine the exact form or embodiment. The above description should be viewed more than the illustration, not as a restriction. It is obvious that specialists in this field can have many modifications and variations. The embodiment is chosen and described in order to best understand the principles of the present invention and their best practical application for the various embodiments with different modifications suitable for a specific use or implementation adaptation. The scope of the invention is defined by the appending claims, where modifications may be made without deviating from the scope of this invention as defined by said appending claims.

Claims

1. A device for extracting the air from a building with a roof turbofan (2) comprising:

- a roof turbofan (2),
- an air storage tank (1),
- a clutch (4),
- a shaft (3) connecting the turbofan (2) and the clutch (4), **characterized in that** the air storage tank (1) comprising,

- an isobaric air tank weight (8);
- an air intake valve (14)
- an air exhaust pipe (13), and

the device furthermore comprising:

- a multi-stage gear transmission (5) connected to the shaft (3) and connected by a cable (12) passing through a pulley (9) to the isobaric air tank weight (8) for converting a high speed and a low torque to a low speed and a high torque allowing the isobaric air tank weight (8) to be lifted,
- a compressed air driven turbofan (10) connected to the air exhaust pipe (13),
- an air outlet (11) of the compressed air driven turbofan (10).

2. The device for extracting the air from the building according to claim 1, **characterized in that** the compressed air driven turbofan (10) is placed behind the air exhaust pipe (13) at the other end of the air exhaust pipe (13) other than the air storage tank (1), and has a connection with the ambient air.

3. The device for extracting the air from the building according to the preceding claims, **characterized in that** the air outlet (11) comprises, among other elements, an opening through which the air is released from the building (6).

4. The device for extracting the air from the building according to the preceding claims, **characterized in that** the exhaust pipe (13) is tightly connected to the air storage tank (1) and the other end of the air exhaust pipe (13) is directed to the compressed air driven turbofan (10) in the air outlet (11) or near to it.

5. The device for extracting the air from the building according to the preceding claims, **characterized in that** the roof turbofan (2) is mechanically connected through the shaft (3) and the clutch (4) to the multi-stage gear transmission (5) which converts a high-speed and low-torque rotation of the roof turbofan (2) into a low-speed, high-torque rotation.

6. The device for extracting the air from the building according to the preceding claims, **characterized in that** the pulley (9) is attached above the air storage tank (1).
7. The device for extracting the air from the building according to the preceding claims, **characterized in that** the air intake valve (14) is attached to the air storage tank (1).
8. The device for extracting the air from the building according to the preceding claims, **characterized in that** the cable (12) which extends through the pulley (9) and is attached to the isobaric air tank weight (8) is attached to the output axis of the multi-stage gear transmission (5).
9. A method of extracting the air from the building using the device according to the preceding claims having the following steps:
- the wind rotates the roof turbofan (2);
 - the roof turbofan (2) extracts the air from the building (6) to the outside;
 - the fresh air enters the building (6) through air intake openings (7) of the building;
 - when the roof turbofan (2) starts rotating faster than required to ensure the required ventilation, a torque of the roof turbofan (2) is transmitted to the multi-stage gear transmission (5) through the shaft (3) and the clutch (4);
 - the multi-stage gear transmission (5) converts from a high speed and a low torque to a low speed and a high torque, which allows the isobaric air tank weight (8) to be lifted;
 - when the isobaric air tank weight (8) is lifted to the maximum (as planned in the structure), the air storage tank (1) is filled to the maximum with the air through the air intake valve (14);
 - the clutch (4) disconnects the shaft (3) from the multi-stage gear transmission (5); the isobaric air tank weight (8) is released to fall;
 - when the isobaric air tank weight (8) falls, it compresses the air in the air storage tank (1);
 - the air being compressed enters the compressed air driven turbofan (10) through the air exhaust pipe (13) and starts rotating it;
 - the rotating compressed air driven turbofan (10) sucks the air from the building (6), which is released through the air outlet (11);
 - when the isobaric air tank weight (8) reaches the lowest position, the compressed air driven turbofan (10) stops operating.

Patentansprüche

1. Vorrichtung zum Absaugen der Luft aus einem Ge-

bäude mit einem Dach-Turbofan (2), umfassend:

- ein Dach-Turbofan (2),
- einen Luft-Vorratsbehälter (1),
- eine Kupplung (4),
- eine Welle (3), die den Turbofan (2) und die Kupplung (4) verbindet,

dadurch gekennzeichnet, dass

der Luft-Vorratsbehälter (1) Folgendes umfasst:

- ein isobares Luft-Vorratsbehälter-Gewicht (8);
- ein Lufteinlassventil (14)
- ein Abluftrohr (13), und

wobei die Vorrichtung weiterhin umfasst:

- ein mehrstufiges Getriebe (5), das mit der Welle (3) verbunden ist und über ein durch eine Riemenscheibe (9) geführtes Seil mit dem isobaren Luft-Vorratsbehälter-Gewicht (8) verbunden ist, um eine hohe Geschwindigkeit und ein niedriges Drehmoment in eine niedrige Geschwindigkeit und ein hohes Drehmoment umzuwandeln, wodurch es ermöglicht wird, das isobare Luft-Vorratsbehälter-Gewicht (8) anzuheben,
- einen druckluftbetriebenen Turbofan (10), der mit dem Abluftrohr (13) verbunden ist,
- einen Luftauslass (11) des druckluftbetriebenen Turbofans (10).

2. Vorrichtung zum Absaugen der Luft aus einem Gebäude nach Anspruch 1, **dadurch gekennzeichnet, dass** der druckluftbetriebene Turbofan (10) hinter dem Abluftrohr am anderen Ende als am Luft-Vorratsbehälter (1) des Abluftrohrs (13) angeordnet ist und eine Verbindung mit der Umgebungsluft hat.
3. Vorrichtung zum Absaugen der Luft aus einem Gebäude nach den vorhergehenden Ansprüchen, **dadurch gekennzeichnet, dass** der Luftauslass (11) unter anderem eine Öffnung umfasst, durch die die Luft aus dem Gebäude (6) abgeführt wird.
4. Vorrichtung zum Absaugen der Luft aus einem Gebäude nach den vorhergehenden Ansprüchen, **dadurch gekennzeichnet, dass** das Abluftrohr (13) dicht mit dem Luft-Vorratsbehälter (1) verbunden ist und das andere Ende des Abluftrohrs (13) zum druckluftbetriebenen Turbofan (10) im Luftauslass (11) oder in dessen Nähe gerichtet ist.
5. Vorrichtung zum Absaugen der Luft aus einem Gebäude nach den vorhergehenden Ansprüchen, **dadurch gekennzeichnet, dass** der Dach-Turbofan (2) mechanisch über die Welle (3) und die Kupplung (4) mit dem mehrstufigen Getriebe (5) verbunden ist, das eine hohe Geschwindigkeit und ein niedriges

Drehmoment des Dach-Turbofans (2) in eine niedrige Geschwindigkeit und ein hohes Drehmoment umwandelt.

6. Vorrichtung zum Absaugen der Luft aus einem Gebäude nach den vorhergehenden Ansprüchen, **dadurch gekennzeichnet, dass** die Riemenscheibe (9) über dem Luft-Vorratsbehälter (1) angebracht ist. 5
7. Vorrichtung zum Absaugen der Luft aus einem Gebäude nach den vorhergehenden Ansprüchen, **dadurch gekennzeichnet, dass** das Lufteinlassventil (14) am Luft-Vorratsbehälter (1) angebracht ist. 10
8. Vorrichtung zum Absaugen der Luft aus einem Gebäude nach den vorhergehenden Ansprüchen, **dadurch gekennzeichnet, dass** das Seil (12), das sich durch die Riemenscheibe (9) erstreckt und an dem isobaren Luft-Vorratsbehälter-Gewicht (8) befestigt ist, an der Abtriebsachse des mehrstufigen Zahnradgetriebes (5) befestigt ist. 15 20
9. Verfahren zum Absaugen der Luft aus einem Gebäude unter Verwendung der Vorrichtung nach den vorhergehenden Ansprüchen, das die folgenden Schritte aufweist: 25
- der Dach-Turbofan (2) wird vom Wind gedreht;
 - der Dach-Turbofan (2) saugt die Luft aus dem Gebäude (6) nach außen ab; 30
 - die Frischluft tritt durch die Zuluftöffnungen (7) des Gebäudes in das Gebäude (6) ein;
 - wenn der Dach-Turbofan (2) schneller zu rotieren beginnt als für die erforderliche Belüftung erforderlich ist, wird das Drehmoment des Dach-Turbofans (2) über die Welle (3) und die Kupplung (4) auf das mehrstufige Getriebe (5) übertragen: 35
 - das mehrstufige Getriebe (5) wandelt eine hohe Geschwindigkeit und ein niedriges Drehmoment in eine niedrige Geschwindigkeit und ein hohes Drehmoment um, wodurch es ermöglicht wird, das isobare Luft-Vorratsbehälter-Gewicht (8) anzuheben; 40
 - wenn das isobare Luft-Vorratsbehälter-Gewicht (8) bis zum Maximum angehoben wird (wie in der Konstruktion vorgesehen), wird der Luft-Vorratsbehälter (1) bis zum Maximum mit Luft durch das Lufteinlassventil (14) gefüllt; 45
 - die Kupplung (4) trennt die Welle (3) vom mehrstufigen Getriebe (5) ab; das isobare Luft-Vorratsbehälter-Gewicht (8) wird zum Fallen freigegeben; 50
 - wenn das isobare Luft-Vorratsbehälter-Gewicht (8) fällt, komprimiert es die Luft im Luft-Vorratsbehälter (1): 55
 - die komprimierte Luft tritt durch das Abluftrohr (13) in den druckluftbetriebenen Turbofan (10)

ein und beginnt, ihn zu drehen;

- der rotierende druckluftbetriebene Turbofan (10) saugt die Luft aus dem Gebäude (6) an, die durch den Luftauslass (11) abgegeben wird;
- wenn das isobare Luft-Vorratsbehälter-Gewicht (8) die niedrigste Position erreicht, stellt der druckluftbetriebene Turbofan (10) den Betrieb ein.

Revendications

1. Dispositif d'extraction d'air d'un bâtiment à turbosoufflante de toit (2) comprenant :

- une turbosoufflante de toit (2),
- un réservoir de stockage d'air (1),
- un embrayage (4),
- un arbre (3) reliant la turbosoufflante (2) et l'embrayage (4),

caractérisé en ce que

le réservoir de stockage d'air (1) comprenant,

- un poids de réservoir d'air isobare (8) ;
- une soupape d'admission d'air (14)
- un tuyau d'échappement d'air (13), et

le dispositif comprenant en outre :

- une transmission à engrenages à plusieurs étages (5) reliée à l'arbre (3) et reliée par un câble (12) passant par une poulie (9) jusqu'au poids de réservoir d'air isobare (8) du réservoir d'air pour convertir une vitesse élevée et un faible couple en une vitesse faible et un couple élevé permettant de soulever le poids de réservoir d'air isobare (8),
- Une turbosoufflante (10) entraînée par air comprimé connecté au tuyau d'échappement d'air (13),
- une sortie d'air (11) de la turbosoufflante (10) entraînée par air comprimé.

2. Le dispositif d'extraction d'air du bâtiment selon la revendication 1, **caractérisée en ce que** la turbosoufflante (10) entraînée par air comprimé est placée derrière le tuyau d'échappement d'air (13) à l'autre extrémité du tuyau d'évacuation d'air (13) autre que le réservoir de stockage d'air (1), et a une connexion avec l'air ambiant.

3. Le dispositif d'extraction d'air du bâtiment selon les revendications précédentes, **caractérisées en ce que** la sortie d'air (11) comprend, entre autres éléments, une ouverture par lequel l'air est évacué du bâtiment (6).

4. Le dispositif d'extraction d'air du bâtiment selon les revendications précédentes, **caractérisées en ce que** le tuyau d'échappement (13) est étroitement relié au réservoir de stockage d'air (1) et l'autre extrémité du tuyau d'échappement d'air (13) est dirigée vers la turbosoufflante entraînée par air comprimé (10) dans la sortie d'air (11) ou à proximité. 5
5. Le dispositif d'extraction d'air du bâtiment selon les revendications précédentes, **caractérisée en ce que** la turbosoufflante de toit (2) est reliée mécaniquement à travers l'arbre (3) et l'embrayage (4) à la transmission à engrenages à plusieurs étages (5) qui convertit une rotation à vitesse élevée et à faible couple de la turbosoufflante de toit (2) en une rotation à faible vitesse et à couple élevé. 10 15
6. Le dispositif d'extraction d'air du bâtiment selon les revendications précédentes, **caractérisées en ce que** la poulie (9) est fixée au-dessus du réservoir de stockage d'air (1). 20
7. Le dispositif d'extraction d'air du bâtiment selon les revendications précédentes, **caractérisées en ce que** la vanne d'admission d'air (14) est fixée sur le réservoir de stockage d'air (1). 25
8. Le dispositif d'extraction d'air du bâtiment selon les revendications précédentes, **caractérisées en ce que** le câble (12) qui s'étend à travers la poulie (9) et est attaché au poids du réservoir d'air isobare (8), est attaché à l'axe de sortie de la transmission à engrenages à plusieurs étages (5). 30
9. Un procédé d'extraction de l'air du bâtiment à l'aide du dispositif selon les revendications précédentes comportant les étapes suivantes : 35
- le vent fait tourner la turbosoufflante de toit (2) ;
 - la turbosoufflante de toit (2) extrait l'air du bâtiment (6) vers l'extérieur ; 40
 - l'air frais pénètre dans le bâtiment (6) par des ouvertures d'admission d'air (7) du bâtiment ;
 - lorsque la turbosoufflante de toit (2) commence à tourner plus vite que nécessaire pour assurer la ventilation requise, un couple de la turbosoufflante de toit (2) est transmis à la transmission à engrenages multi-étages (5) via l'arbre (3) et l'embrayage (4) ; 45
 - la transmission à engrenages à plusieurs étages (5) passe d'une vitesse élevée et d'un faible couple à une vitesse faible et à un couple élevé, ce qui permet de soulever le poids du réservoir d'air isobare (8) ; 50
 - lorsque le poids du réservoir d'air isobare (8) est levé au maximum (comme prévu dans la structure), le réservoir de stockage d'air (1) est rempli au maximum avec l'air à travers la vanne d'admission d'air (14) ; 55
 - l'embrayage (4) déconnecte l'arbre (3) de la transmission à engrenages à plusieurs étages (5) ; le poids du réservoir d'air isobare (8) est libéré pour qu'il tombe ;
 - lorsque le poids du réservoir d'air isobare (8) tombe, il comprime l'air dans le réservoir de stockage d'air (1) ;
 - l'air comprimé entre dans la turbosoufflante entraînée par air comprimé (10) par le tuyau d'échappement d'air (13) et commence à le faire tourner ;
 - la turbosoufflante rotative entraînée par air comprimé (10) aspire l'air du bâtiment (6), qui est libéré par la sortie d'air (11) ;
 - lorsque le poids du réservoir d'air isobare (8) atteint la position la plus basse, la turbosoufflante entraînée par air comprimé (10) s'arrête de fonctionner.

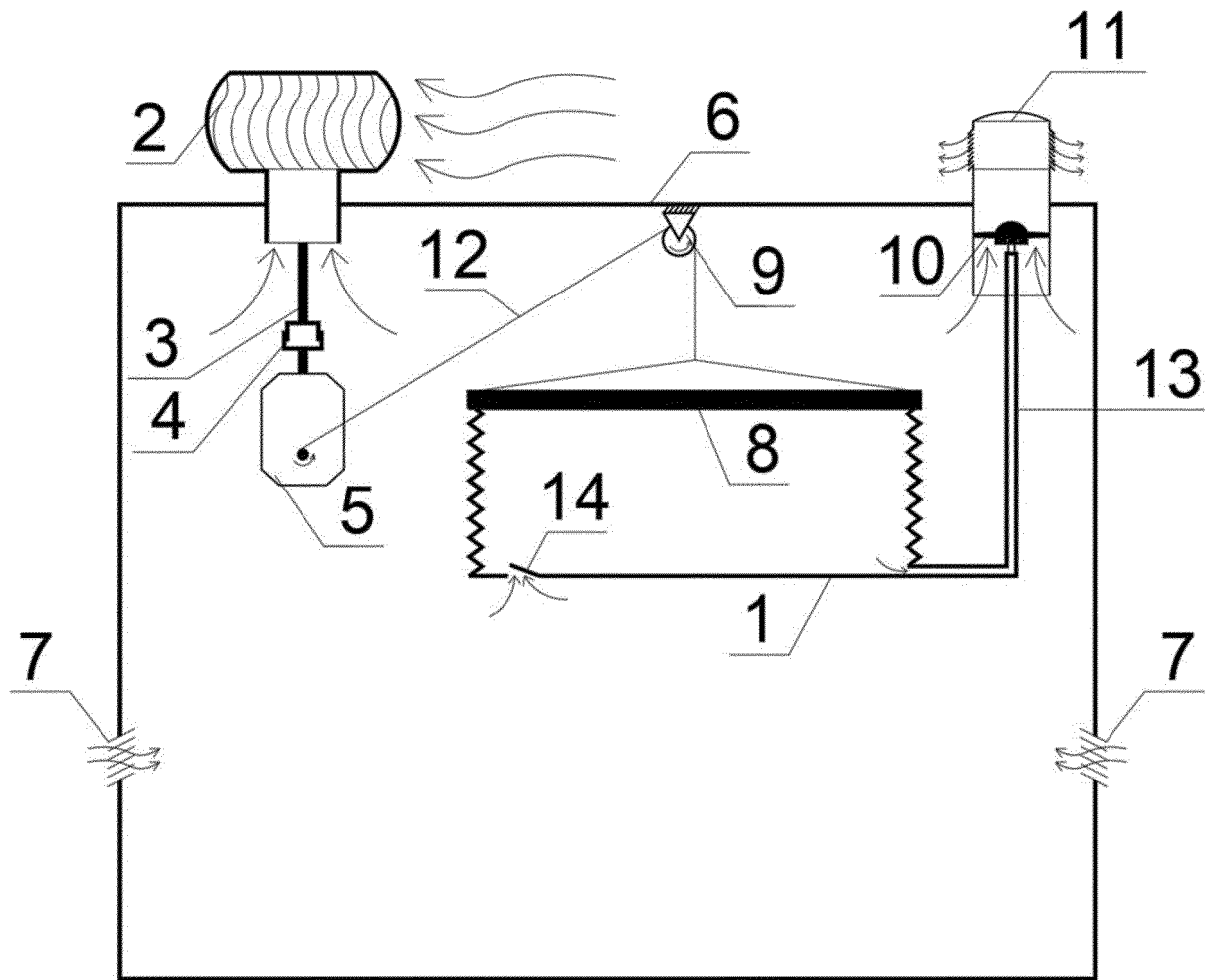

FIG. 1

REFERENCES CITED IN THE DESCRIPTION

This list of references cited by the applicant is for the reader's convenience only. It does not form part of the European patent document. Even though great care has been taken in compiling the references, errors or omissions cannot be excluded and the EPO disclaims all liability in this regard.

Patent documents cited in the description

- LT 6613 B [0005]