



(11) **EP 3 769 818 A1**

(12) **EUROPEAN PATENT APPLICATION**

(43) Date of publication:
27.01.2021 Bulletin 2021/04

(51) Int Cl.:
A62B 35/00 (2006.01)

(21) Application number: **19382635.1**

(22) Date of filing: **25.07.2019**

(84) Designated Contracting States:
AL AT BE BG CH CY CZ DE DK EE ES FI FR GB GR HR HU IE IS IT LI LT LU LV MC MK MT NL NO PL PT RO RS SE SI SK SM TR
Designated Extension States:
BA ME
Designated Validation States:
KH MA MD TN

(71) Applicant: **FALLPROTEC, S.L.**
08339 Vilassar de Dalt (ES)

(72) Inventor: **FERNANDEZ GARCIA, José**
08339 Vilassar de Dalt (ES)

(74) Representative: **Sugrañes Patentes y Marcas**
Calle Provenza 304
08008 Barcelona (ES)

(54) **A FALL-PROTECTION COUNTERWEIGHT APPARATUS**

(57) The invention relates to a fall-protection counterweight apparatus (100) for counterbalancing the weight of a user of a fall-protection element (200) with a mast (201). The counterweight apparatus comprises a mast receiving module and a base module. The base module is formed by a base plate (1) provided in the lower portion with a plurality of leveling support legs (2) for the horizontal arrangement of the base plate, and in the upper portion with a plurality of projecting elements (5) perpendicular to the base plate for fixing counterweight elements (17) arranged on the base plate. The receiving module is arranged on the upper face of the base plate and comprises a tubular body (6) with a hollow for tightly housing the mast of the fall-protection element (200).

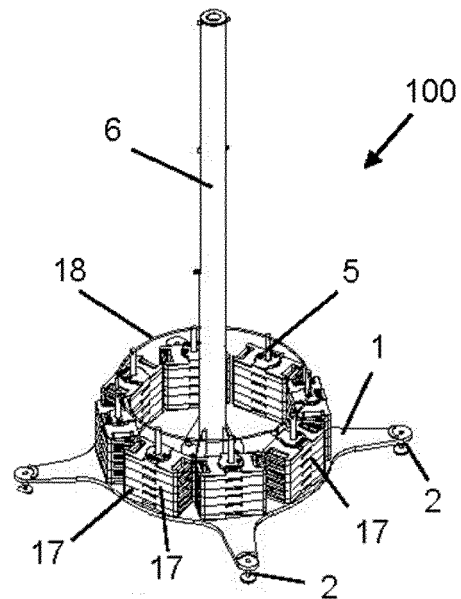

Fig. 2

EP 3 769 818 A1

Description

Technical field of the invention

[0001] The present invention relates to a fall-protection counterweight apparatus for counterbalancing the weight of a user of a fall-protection element, in particular a fall-protection element of the type comprising a mast.

[0002] The counterweight apparatus is of the type comprising a mast receiving module for housing the mast of the fall-protection element, and a base module provided with a plurality of support legs for ensuring the stable support of the counterweight apparatus on a surface, either on a terrain, the floor slab of a building under construction, etc.

Background of the invention

[0003] Operators who work at heights in the construction sector, such as for example, the preparation of formwork for horizontal surfaces, floor slabs, flat beams, etc. run a serious risk of falling, so individual protection devices have been developed to prevent the operator from falling and at the same time not excessively limiting his freedom of movement so as to suitably perform his job.

[0004] An example of an individual fall-protection device is the one described in patent document EP1400642-B1, particularly indicated for work on horizontal surfaces in construction works, in which the anchoring means are made up of an anchoring element, suitable for being inserted into a mass of concrete or mortar in a fluid state, and remaining solidified to the same after the setting or hardening of said mass. The safety device is essentially characterised in that the attachment means are made up of a mast, removably coupled at its lower part to said anchoring element with the possibility of pivoting on its vertical axis, and attached, at its upper part, to the upper end of a rope which, at its lower end is linked to the mentioned fastening means, the rope being able to rotate with respect to the vertical axis of the mast, such that the operator is firmly fastened with the possibility of moving freely within an essentially circular field of action, around said vertical axis. Preferably the anchoring element is a sleeve which receives in its interior the lower end of the mast with the possibility of pivoting on its vertical axis. The attachment means further comprise an upper rotating member, attached to the mast, with the possibility of rotating with respect to the latter on its vertical axis. It is envisaged that said upper rotating member comprises a rotating jib into the free end of which the upper end of the rope is fixed. The device may comprise an arm fitted with a fixed or movable compensating ballast at the opposite end of the rotating jib. Preferably, the rope comprises energy absorbing means, adapted for preventing the operator from suffering an impact by the jerking of the rope in the event of an accidental fall.

[0005] Another device example is the one described

in patent application EP3002044-A1, which discloses a fall-protection system for securely coupling a user to a support structure. This fall-protection system comprises a mast arranged to be vertically mounted in a state of use, having a top end and a base end; a user connection assembly; and a tether connector; wherein the mast comprises a structure connection portion, in which the mast is arranged to be removably connected to the support structure, and an energy absorbing deformation portion positioned closer to the top end than the structure connection portion. One of the figures of document EP3002044-A1 illustrates how the fall-protection system is mounted in a type of support structure, which consists of a transportable anchor, which in short comprises a frame structure and counterweights, such as concrete weights, placed in the frame structure. The transportable anchor further has an anchoring member which receives the structure connection portion of the mast of the protection system. As indicated, the transportable anchor is used in situations when a user is going to work on the roof of a lorry.

[0006] Document ES2639164-T3 describes a fall-protection counterweight apparatus for counterbalancing the weight of a user. The apparatus has a top module having a plurality of horizontal members that support a plurality of top leg couplers and a mast coupler; a base module having a plurality of horizontal members, each of the horizontal members extending between a pair of base leg couplers; a stowage module coupled to the base module and arranged within an interior region coplanar with the horizontal members of the base module; and a plurality of legs. In a fall-protection mode adapted for operation, the top module is spaced apart from the base module by the plurality of legs, each of the legs being releasably coupled at opposing ends to one of the top leg couplers and one of the base leg couplers. In contrast, in a low profile mode adapted for storage, the top module is directly coupled to the base module coupled by one of the corresponding top base leg couplers, each of the legs arranged within the stowage module.

[0007] An objective of the present invention is to disclose an alternative to these known counterweight apparatus or structures, the assembly of which is easy and intuitive, with simple components that can be adapted to the counterweight needs accordingly. Furthermore, the use thereof must be comfortable and simple, without requiring considerable space for the on-site assembly and disassembly, and it must provide the necessary safety at all times in apparatus of this type against slipping and unwanted or accidental extractions of the elements or materials performing the counterweight function.

Description of the invention

[0008] For the purpose of providing a solution to the objectives that are considered, a fall-protection counterweight apparatus for counterbalancing the weight of a user of a fall-protection element with a mast is disclosed.

The counterweight apparatus comprises a mast receiving module and a base module provided with a plurality of support legs.

[0009] Essentially, the counterweight apparatus object of the invention is characterised in that the base module is formed by a base plate provided on its lower face with a plurality of leveling support legs for the horizontal arrangement of the base plate, and provided on its upper face with a plurality of projecting elements extending from the base plate in the direction perpendicular to the upper face of the base plate, said projecting elements being provided for fixing counterweight elements that are arranged on the base plate. The counterweight apparatus object of the invention is also characterised in that the mast receiving module is arranged on the upper face of the base plate and comprises a tubular body, the hollow of which is sized for tightly housing the mast of a fall-protection element.

[0010] The base plate is a plate arranged horizontally and can be a flat plate, a plate with folds or a pressed plate. It is preferably a metal plate, although manufacturing it in another material capable of withstanding the stress generated by the user of the fall-protection element, the mast of which is tightly housed in the tubular body of the mast receiving module, is not ruled out. The base plate extends horizontally covering a distance between leveling support legs spanning a large dimensional range, for example from 500 mm to 2000 mm. The base plate can have any type of geometric shape (circular, square, polygonal, arbitrary, etc.), provided that its shape allows supporting the same on a plurality of leveling support legs, as a minimum three legs and preferably four.

[0011] According to a feature of the invention, the leveling support legs have a key profile for the manual level adjustment thereof and are attached to the base plate through threaded pins protruding from the lower face of the base plate. Preferably, these threaded pins are welded to the lower face of the base plate.

[0012] There can be arranged on the base plate, fixed thereto, for example by means of screws, a glass or aluminium surface level device to verify the correct level of the upper face of the base plate, i.e., to confirm that the base plate is arranged horizontally and if it is not, to correct the level thereof by adjusting the different support legs with the key.

[0013] These leveling legs can be stiff, as indicated above, or alternatively, they may comprise ball joints to ensure better adaptation to any type of terrain. Preferably the leveling support legs with a ball joint are also screwed on threaded pins projecting from the lower face of the base plate, preferably welded to said face.

[0014] The base module, including leveling support legs, represents a structure, the architecture of which facilitates the stock pile and storage thereof. Thus, according to a preferred embodiment of the invention, the base module is stackable on another base module, and on the upper face of the base plate there are arranged positioning stops protruding from the surface of the upper

face of the base plate, partially or completely demarcating a positioning area for the feet of the leveling support legs of a base module stacked thereon. These positioning stops can be formed by small plates of any material and be welded or screwed on the upper face of the base plate, in a position above where the leveling support legs of the base module are located. Preferably, when the feet of the legs are disc-shaped, the positioning stops can have a curved shape or be banana-shaped to abut with a part of the perimeter of the disc of the foot of the leg of the base module to be stacked on the base plate.

[0015] According to another feature of the invention, the mast receiving module comprises the tubular body, the hollow of which is sized for tightly housing the mast of a fall-protection element, said tubular body being provided with an open free end and a closed end. The mast receiving module further comprises a coupling support attached to the upper face of the base plate of the base module configured in the form of a plate for coupling the closed end of the tubular body to the base plate. In an operative position of the counterweight apparatus, in which the apparatus acts by counterbalancing the weight of the user of the protection element, the mast of which is housed in the tubular body, the axial axis of the tubular body is arranged in a direction perpendicular to the upper face of the base plate. The coupling support can be stiffly attached to the base plate by means of welding or mechanically through a screwed or riveted attachment.

[0016] According to another feature of the invention, the closed end of the tubular body is formed by a plate flange in which there are arranged stiffening elements attached to the end part of the tubular body, the tubular body being integrally attached to the plate flange with the axial axis of the tubular body arranged in the direction perpendicular to the plate flange.

[0017] According to a particular embodiment of the counterweight apparatus, the plate flange and the coupling support are attached to one another by means of a hinged attachment whereby the tubular body, in a non-operative position of the counterweight apparatus, is rotatable with respect to the base plate, the axial axis of the tubular body with respect to the direction perpendicular to the upper face of the base plate forming angles comprised between 90° and 0°. In the operative position of the counterweight apparatus, the plate flange and the coupling support are attached to one another by means of a screwed attachment whereby the plate flange and the coupling support are arranged in parallel planes without being rotatable with respect to one another.

[0018] According to another particular embodiment of the counterweight apparatus, devoid of a hinged attachment, the plate flange and the coupling support are attached to one another by means of a screwed attachment, whereby the plate flange and the coupling support are arranged in parallel planes without being rotatable with respect to one another. The screwed attachment allows disassembling the plate flange from the coupling support, and with it separating the tubular element from

the base plate.

[0019] According to another feature of the invention, the tubular body can be provided externally with at least rolling transport means for the tubular body, such as a wheel. The tubular body can also be provided with hooking means for the tubular body, for example eyebolt-type means, welded to the surface of the tubular body to facilitate the hooking and subsequent dragging or lifting thereof.

[0020] According to another particular embodiment of the invention, the projecting elements for fixing counterweight elements are formed by projecting bars integrally or removably attached to the base plate arranged around the tubular body of the mast receiving module, and the counterweight elements are formed by stackable elements provided with a through hole whereby the counterweight element can be inserted on one of the projecting bars forming the plurality of the projecting elements. Thus, the counterweight elements can be counterweight modules (made of iron, steel, concrete...) in the form of ingots having a through housing, the axis of which is parallel to the projecting element and perpendicular to the two largest faces of the counterweight element.

[0021] The projecting bars can be permanently attached to the base plate by means of welding or they can be mechanically attached elements that can be disassembled. In the event of mechanical attachment, one of the ends must have a projection that screws into a hole made in the base plate.

[0022] According to another additional feature of this particular embodiment, each projecting bar is provided at its end farthest away from the base plate with a through hole, and the counterweight apparatus comprises a perimeter safety element to prevent extraction of the counterweight elements provided with two ends, the perimeter safety element being susceptible to being inserted in the through hole of the projecting bars, and the ends of the perimeter safety element being fitted with mutual attachment means, the perimeter safety element determining, with its attached ends, a closed perimeter, arranged through the ends of the projecting bars and around the tubular body, such that the movement capacity of the counterweight elements, stacked and inserted on a projecting bar, along said bar is limited in the lower portion by the upper face of the base plate and in the upper portion by the perimeter safety element. Thus, the perimeter safety element can be formed by a chain, rope, wire, cable or similar filiform element provided at the ends thereof with a lock to thus ensure that it is not possible to disassemble the counterweight elements that are arranged with the projecting bars of the base module going through them without the corresponding authorisation.

[0023] According to another additional feature of this particular embodiment, the upper face of the base plate comprises visual positioning elements for placing the counterweight elements. These visual positioning elements can be formed by laminar portions of an anti-abrasion material or a non-slip material. The visual positioning

elements can be, for example, vinyls, gum adhered by adhesive attachment means, or pieces of neoprene glued to the upper face of the base plate.

[0024] According to another alternative embodiment, the projecting elements for fixing counterweight elements are not formed by projecting bars, but rather the elements are arranged around the tubular body of the mast receiving module and are formed by elements for fixing panels which, when fixed to the projecting elements, form a self-supporting structure having a closed perimeter on the base plate susceptible to depositing within said perimeter a material or materials, the weight of which constitutes the counterweight elements. For example, any type of material can be deposited without the particles or elements forming it acquiring a structured arrangement (sand, pieces of steel together with concrete, stones, etc.).

Brief description of the drawings

[0025] The accompanying drawings illustrate preferred embodiments of the counterweight apparatus object of the invention by way of non-limiting example. In said drawings:

Figure 1 is a perspective view of a first preferred embodiment of the fall-protection counterweight apparatus object of the invention in which a fall-protection element has been assembled with its mast housed in the tubular body of the mast receiving module of the apparatus;

Figure 2 is a perspective view of only the counterweight apparatus shown in Figure 1;

Figure 3 is an elevation view of the counterweight apparatus and of the fall-protection element shown in Figure 1;

Figure 4 is a plan view of the counterweight apparatus and of the fall-protection element shown in Figure 1;

Figure 5 is a view of the base module of the counterweight apparatus of Figure 2 with an enlarged detail;

Figure 6 is a plan view of the base module of Figure 5;

Figure 7 is a perspective view of the counterweight apparatus of Figure 2 without projecting elements or counterweight elements.

Figure 8 is a cross-sectional view of the counterweight apparatus of Figure 7 according to a vertical cutting plane, including two enlarged detail views;

Figure 9 is a view of a third embodiment of the coun-

terweight apparatus of the invention in which the mast receiving module comprises a plate flange attached by means of a hinge to the coupling support, in a non-operative position, and with an enlarged detail view;

Figure 10 is an exploded perspective view of the base module comprising projecting elements in the form of bars that can be disassembled from the base plate;

Figure 11 is a view of the base module of Figure 10 with the elements assembled according to an operative position, without showing the counterweight elements;

Figure 12 is a perspective view of the base module of Figure 10 showing the assembly of the counterweight elements;

Figure 13 is a perspective view of the counterweight apparatus according to another preferred embodiment in which the tubular body is provided with rolling transport means and with hooking means for the tubular body.

Detailed description of the drawings

[0026] Figures 1, 3 and 4 show a fall-protection element 200, intended for being used by an operator who works at heights, in which the mast 201 is coupled and partially introduced by its lower segment into a counterweight apparatus 100. The counterweight apparatus 100, which is shown separately in Figure 2, basically comprises a mast receiving module and a base module on which are arranged several counterweight elements 17 distributed in stacks.

[0027] The base module is formed by a base plate 1 provided on its lower face with a plurality of leveling support legs 2 for the horizontal arrangement of the base plate 1, as shown in Figures 5 and 6.

[0028] The base plate 1 is preferably a flat plate, although it can be a plate with folds or a pressed plate. Preferably it is a metal plate, although manufacturing it in another material capable of withstanding the stress generated by the user of the fall-protection element 200, the mast 201 of which is tightly housed in the counterweight apparatus 100, is not ruled out. The base plate 1 extends horizontally covering a distance between leveling support legs 2 spanning a large dimensional range, for example from 500 mm to 2000 mm. The base plate 1 can have any type of geometric shape provided that its shape allows supporting the same on a plurality of leveling support legs 2, as a minimum 3 legs and preferably four, like in the embodiments depicted in the drawings. In the case that is depicted, the base plate 1 has a circular central shape on which the counterweight elements are placed and from which there emerge four prolongations

in the radial direction at the ends of which the leveling support legs 2 are located.

[0029] The leveling support legs 2 have a key profile (not depicted) for the manual level adjustment thereof and are attached to the base plate 1 through threaded pins 3 protruding from the lower face of the base plate 1. Preferably, these threaded pins 3 are welded to the lower face of the base plate 1.

[0030] There can be arranged on the base plate 1, fixed thereto, for example by means of screws, a glass or aluminium surface level device 82 (depicted in the base plate 1 of Figures 10 and 11) to verify the correct level of the upper face of the base plate 1, i.e., to confirm that the base plate 1 is arranged horizontally and if it is not, to correct the level thereof by adjusting the different support legs 2 with the key.

[0031] Though not depicted in the figures, the leveling support legs 2 may comprise ball joints for adapting the feet of the legs to the surface on which the counterweight apparatus 100 is supported.

[0032] It has advantageously been envisaged that the base module is stackable on another base module. To that end, on the upper face of the base plate 1 there are arranged positioning stops 4 protruding from the surface of the upper face, partially or completely demarcating a positioning area for the feet of the leveling support legs 2 of a base module to be stacked thereon. The positioning stops 4 can be formed by small plates of any material and can be welded or screwed on the upper face of the base plate 1. Preferably, when the feet of the leveling support legs 2 are disc-shaped, as depicted in the figures, the positioning stops 4 can have a curved shape or be banana-shaped to abut with a part of the perimeter of the disc of the foot of the leveling leg 2 of the base module to be stacked on the base plate 1.

[0033] It can be seen in Figures 5 and 6 that there are made on the upper face of the base plate 1 a first series of holes 85 distributed along the circular perimeter of the base plate 1 and a second series of central holes 81. The holes 85 of the first series enable the placement of respective projecting elements 5, extending vertically, i.e., in a direction perpendicular to the upper face of the base plate 1, protruding from the same. The projecting elements 5, which can be seen in detail in Figures 10 to 12, are used to fix the counterweight elements 17 which are arranged on the upper face of the base plate 1.

[0034] According to the preferred embodiments of the counterweight apparatus 100, the depicted projecting elements 5 are formed by projecting bars removably attached to the base plate 1 in the positions marked by the holes 85 of the first series, thus being able to easily assemble and disassemble it when the counterweight apparatus 100 is to be put away. Nevertheless, other embodiments in which the projecting bars are integrally attached to the base plate 1 by welding are not ruled out.

[0035] When the projecting elements 5 are formed by the mentioned projecting bars, the counterweight elements 17 are formed by stackable elements provided

with a through hole 83 (see one of the enlarged detail views of Figure 12) whereby the counterweight element 17 can be inserted on one of the projecting bars. Thus, the counterweight elements 17 can be counterweight modules (made of iron, steel, concrete...) in the form of ingots, stackable one on top of another, having a through hole, the axis of which is parallel to the projecting element 5 and perpendicular to the two largest faces of the counterweight element 17.

[0036] The projecting bars forming the projecting elements 5 can be permanently attached to the base plate 1 by means of welding or they can be mechanically attached elements that can be disassembled. In the event of mechanical attachment, as shown in one of the enlarged details of Figure 12, each projecting element 5 has at its lower end a protuberance 51 provided with a threaded outer surface complementary to the threading of one of the holes 85 of the first series made in the base plate 1.

[0037] Furthermore, in the other upper enlarged detail shown in Figure 12, it can be seen that each projecting bar is provided at its end farthest away from the base plate 1 with a through hole 50 adapted for the passage therethrough of a perimeter safety element 18 to prevent extraction of the counterweight elements 17.

[0038] The perimeter safety element 18 can be formed by a chain, rope, wire, cable or similar filiform element provided with two ends 19 (see Figure 10). Once the perimeter safety element 18 has been placed going through all the through holes 50 of the projecting bars, said ends 19 are attached to one another, determining a closed perimeter. The ends 19 can be attached through a safety latching device, such as a lock, to thus ensure that it is not possible to disassemble the counterweight elements arranged such that the projecting bars of the base module go through them without the corresponding authorisation. With the ends 19 attached, the movement capacity of the counterweight elements 17, arranged on top of another forming a stack and inserted on a projecting bar, along said bar is limited in the lower portion by the upper face of the base plate 1 and in the upper portion by the perimeter safety element 18.

[0039] In Figures 10 to 12, it can particularly be seen that the upper face of the base plate 1 comprises visual positioning elements 20 for placing the counterweight elements 17 which are first supported on the base plate 1 and after which others will be stacked, forming the stacks necessary for counterbalancing the weight of the user of the fall-protection element 200. These visual positioning elements 20 can be formed by laminar portions of an anti-abrasion material or a non-slip material to prevent the counterweight elements 17 from moving and being able to damage or scratch the surface of the base plate 1. The visual positioning elements 20 can be, for example, vinyls, gum adhered by adhesive attachment means, or pieces of neoprene (for example 2 mm thick) glued to the upper face of the base plate 1.

[0040] Going back to Figure 2, the counterweight ap-

paratus 100 comprises a mast receiving module arranged on the upper face of the base plate 1, comprising a tubular body 6, the hollow of which is sized for tightly housing the mast 201 of the fall-protection element 200, and a coupling support 7 attached to the upper face of the base plate 1 in which it is centrally arranged. The tubular body 6 is provided with an upper open free end and with a lower closed end, as indicated in Figures 7 and 8.

[0041] In Figure 8, it can be seen how the tubular body 6 has, inserted in the area of the upper end forming an insertion opening for inserting the end of the mast 201, an upper guide component 13, and spaced a certain distance below, the tubular body 6 has an additional guide component 14 therein. These guide components act like elements for fastening the mast 201 to keep it within the tubular body 6 in a tight and vertical position. It can also be observed that the lower end of the tubular body 6 is closed by its attachment to the coupling support 7 fixedly attached to the upper face of the base plate, either by welding or preferably by a screwed attachment in which the screws 8 (see Figure 7) are introduced in the holes 81 that are internally threaded for that purpose and provided in the central area of the base plate 1. To reinforce the attachment between the tubular body 6 and the coupling support 7, there are arranged stiffening elements 12.

[0042] In Figure 9, another preferred embodiment of the counterweight apparatus 100 has been depicted in which the lower end of the tubular body 6 is closed by its attachment to a plate flange 11 in which there are arranged stiffening elements 12 attached to the end part of the tubular body 6. In this case, the tubular body 6 is integrally attached to the plate flange 11 with the axial axis of the tubular body 6 arranged in the direction perpendicular to the plate flange 11. As seen in the enlarged detail of the figure, the plate flange 11 and the coupling support 7 are attached to one another by means of a hinged attachment 10 whereby the tubular body 6, in a non-operative position of the counterweight apparatus 100, is rotatable with respect to the base plate 1, the axial axis of the tubular body 6 with respect to the direction perpendicular to the upper face of the base plate 1 forming angles comprised between 90° and 0°.

[0043] In contrast, in the operative position of the counterweight apparatus 100, the plate flange 11 and the coupling support 7 are attached to one another by means of a screwed attachment (see screws 8) whereby the plate flange 11 and the coupling support 7 are arranged in parallel planes, with the axial axis of the tubular body 6 in the direction perpendicular to the base plate 1.

[0044] In Figure 13, the counterweight apparatus 100 is shown in detail in an operative position, prepared for receiving the mast 201 in the tubular body 6 and counterbalancing the weight of the user of the fall-protection element 200. The projecting elements 5 for fixing counterweight elements 17 are arranged around the tubular body 6 of the mast receiving module. In the enlarged

details, it can be seen that the tubular body 6 is provided with rolling transport means 15 such as a wheel, and with hooking means 16 for the tubular body 6, for example eyebolt-type means, welded to the surface of the tubular body 6 to facilitate the hooking and subsequent dragging or lifting thereof.

[0045] The assembly of the counterweight apparatus is very simple and intuitive for users. First, the base plate 1 is placed on the surface of the terrain or ground where the operator using the fall-protection element 200 will be working. The tubular body 6 is transported to said location with the help of the rolling transport means 5 or by means of lifting and moving it with a crane by means of the hooking means 16. The coupling support 7 is centrally placed on the base plate 1. The coupling support 7 has a series of through holes which have to be matched up with the holes 81 made in the base plate 1.

[0046] Several situations may arise. First, the base plate 1 may already have the coupling support 7 placed in its central part, for example previously attached by welding to the base plate 1. In that case, if the tubular body 6 has one of its ends closed by its attachment to a plate flange 11, additionally provided with stiffening elements 12 and threaded through holes provided for the passage therethrough of screws 8, the plate flange 11 is coupled to the coupling support 7 through the hinged attachment 10 and the tubular body 6 will be rotated until the plate flange 11 is supported on the coupling support 7 and the tubular body 6 is in an essentially vertical position, perpendicular to the base plate 1. Then the plate flange 11 will be screwed to the coupling support 7.

[0047] It is also possible for the base plate 1 not to have any coupling support 7 previously attached or screwed to its central part, but rather for the tubular body 6 that has been moved to the base plate 1 to have its end closed by the plate flange 11 and for this plate flange 11 to already be hingedly attached to the coupling support 7. In that case, the tubular body 6 is arranged perpendicular to the base plate 1 and supported on the same by means of the coupling support 7 and the plate flange 11 arranged parallel to the base plate 1. The hinged assembly will be attached by screwing to the base plate 1 by means of inserting the screws 8 into the holes 81.

[0048] In contrast, if the tubular body 6 is not of the type provided with a plate flange 11, its end intended for being the lower end will be attached to the coupling support 7, in turn attached to the base plate 1, either by welding, by screwed attachment, riveted attachment, etc.

[0049] Once the tubular body is placed and attached to the base plate 1, the latter is then leveled by regulating the extension of the leveling support legs 2 and rotating the ball joints thereof should they have any. This is the situation in Figure 7.

[0050] As discussed above, visual positioning elements 20 for placing the counterweight elements 17 to be stacked one on top of another can be arranged in the base plate 1. These visual positioning elements 20 have holes in the positions of the holes 85 of the base plate 1,

and the projecting elements 5 in the form of projecting bars are vertically placed in these positions. The projecting elements 5 preferably have a threaded protuberance 51 for the threaded attachment with the complementary threaded holes 85. Alternatively, the holes 85 can simply be blind holes for fitting the lower end of the projecting bars.

[0051] Once the projecting elements 5 are placed, the counterweight elements 17 in the form of ingots or prisms having a base that is larger than their height and provided with holes 83 for being placed threaded on the projecting elements 5, are inserted on same, as shown in Figure 12. The lower face of each counterweight element 17 is provided with a notch fitting with the shape of a protuberance provided on its upper face to facilitate mutual fitting when the counterweight elements 17 are stacked one on top of another and thus form straight stacks in which the counterweight elements 17 do not move with respect to one another.

[0052] Once a sufficient number of counterweight elements 17 have been placed, the perimeter safety element 18 is placed to prevent extraction of the counterweight elements 17, passing one of the ends 19 through the through holes 50 of all the projecting elements 5 in the form of bars. Immediately after that, the ends 19 are attached to one another by a safety lock and the counterweight elements 17 therefore cannot be extracted without authorisation. Thus, the counterweight apparatus 100 is in the operative position, like that of Figure 2, and is ready for the tubular body 6 to tightly receive in its hollow the mast 201 of the fall-protection element 200; at that point the operator or user can already use said protection element with guarantees that their movements will not entail any risk as their weight and that of the protection element are counterbalanced by the counterweight apparatus 100.

[0053] Once the work at heights has been completed and the operator detached from the fall-protection element 200, the mast 201 is extracted and the counterweight apparatus 100 disassembled, inversely performing the operations carried out for assembly. In the event of having used more than one counterweight apparatus 100 at a site or facility, the base modules may be stacked since the positioning stops 4 are arranged protruding on the surface of the upper face of the base plates 1, partially or completely demarcating a positioning area for the feet of the leveling support legs 2 of a base module to be stacked thereon.

[0054] Finally, it should be mentioned that though not depicted in any of the figures, an alternative embodiment of the counterweight apparatus 100 with respect to that shown is contemplated, in which the projecting elements 5 for fixing counterweight elements 17 are not formed by projecting bars, but rather the projecting elements, likewise arranged around the tubular body 6, are formed by elements for fixing panels which, when fixed to the projecting elements 5, form a self-supporting structure having a closed perimeter on the base plate 1 susceptible

to depositing within said perimeter a material or materials, the weight of which constitutes the counterweight elements 17. For example, any type of material can be deposited without the particles or elements forming it acquiring a structured arrangement (sand, pieces of steel together with concrete, stones, etc.).

Claims

1. A fall-protection counterweight apparatus (100) for counterbalancing the weight of a user of a fall-protection element (200) with a mast (201), in which the counterweight apparatus (100) comprises a mast receiving module and a base module provided with a plurality of support legs, **characterised in that** the base module is formed by a base plate (1) provided on its lower face with a plurality of leveling support legs (2) for the horizontal arrangement of the base plate (1), and provided on its upper face with a plurality of projecting elements (5) extending from the base plate (1) in the direction perpendicular to the upper face of the base plate (1) for fixing counterweight elements (17) arranged on the base plate (1), and **in that** the mast receiving module is arranged on the upper face of the base plate and comprises a tubular body (6), the hollow of which is sized for tightly housing the mast (201) of a fall-protection element (200).
2. The counterweight apparatus (100) according to claim 1, **characterised in that** the leveling support legs (2) have a key profile for the manual level adjustment thereof and are attached to the base plate (1) through threaded pins (3) protruding from the lower face of the base plate (1).
3. The counterweight apparatus (100) according to claim 1 or 2, **characterised in that** the leveling support legs (2) comprise ball joints for adapting the feet of the legs to the surface on which the counterweight apparatus (100) is supported.
4. The counterweight apparatus (100) according to any one of the preceding claims, **characterised in that** the base module is stackable on another base module, there being arranged on the upper face of the base plate (1) positioning stops (4) protruding from the surface of the upper face, partially or completely demarcating a positioning area for the feet of the leveling support legs (2) of a base module susceptible of being stacked thereon.
5. The counterweight apparatus (100) according to any one of the preceding claims, **characterised in that** the base plate (1) is essentially flat.
6. The counterweight apparatus (100) according to any

one of the preceding claims, **characterised in that** the tubular body (6) of the mast receiving module is provided with an open free end and with a closed end, **in that** the mast receiving module further comprises a coupling support (7) attached to the upper face of the base plate (1) of the base module (102) configured in the form of a plate for coupling the tubular body (6) to the base plate (1), the axial axis of the tubular body (6) being in an operative position of the counterweight apparatus (100) arranged in a direction perpendicular to the upper face of the base plate (1).

7. The counterweight apparatus (100) according to claim 6, **characterised in that** the closed end of the tubular body (6) is formed by a plate flange (11) in which there are arranged stiffening elements (12) attached to the end part of the tubular body (6), the tubular body (6) being integrally attached to the plate flange (11) with the axial axis of the tubular body (6) arranged in the direction perpendicular to the plate flange (11).
8. The counterweight apparatus (100) according to claim 7, **characterised in that** the plate flange (11) and the coupling support (7) are attached to one another by means of a hinged attachment (10) whereby the tubular body (6), in a non-operative position of the counterweight apparatus (100), is rotatable with respect to the base plate (1), the axial axis of the tubular body (6) with respect to the direction perpendicular to the upper face of the base plate (1) forming angles comprised between 90° and 0°.
9. The counterweight apparatus (100) according to claim 6 or 7, **characterised in that** the plate flange (11) and the coupling support (7) in an operative position are attached to one another by means of a screwed attachment whereby the plate flange (11) and the coupling support (7) are arranged in parallel planes.
10. The counterweight apparatus (100) according to any one of claims 6 to 9, **characterised in that** the tubular body (6) is provided with at least rolling transport means (15) such as a wheel, and with hooking means (16) for the tubular body (6).
11. The counterweight apparatus (100) according to any one of the preceding claims, **characterised in that** the projecting elements (5) for fixing counterweight elements (17) are formed by projecting bars integrally or removably attached to the base plate (1) arranged around the tubular body (6) of the mast receiving module, and **in that** the counterweight elements (17) are formed by stackable elements provided with a through hole whereby the counterweight element (7) can be inserted on one of the projecting

bars forming the plurality of the projecting elements (5).

12. The counterweight apparatus (100) according to claim 11, **characterised in that** each projecting bar is provided at its end farthest away from the base plate (1) with a through hole (50), and **in that** the counterweight apparatus (100) comprises a perimeter safety element (18) to prevent extraction of the counterweight elements (17) provided with two ends, the perimeter safety element (18) being susceptible to being inserted in the through hole (50) of the projecting bars, and the ends (19) of the perimeter safety element (18) being fitted with mutual attachment means, the perimeter safety element (18) determining, with its attached ends, a closed perimeter, arranged through the ends of the projecting bars and around the tubular body (6), such that the movement capacity of the counterweight elements (17), stacked and inserted on a projecting bar, along said bar is limited in the lower portion by the upper face of the base plate (1) and in the upper portion by the perimeter safety element (18).
13. The counterweight apparatus (100) according to claim 11 or 12, **characterised in that** the upper face of the base plate (1) comprises visual positioning elements (20) for placing the counterweight elements (17).
14. The counterweight apparatus (100) according to claim 13, **characterised in that** the visual positioning elements (20) for placing the counterweight elements (17) are formed by laminar portions of an anti-attribution material or a non-slip material.
15. The counterweight apparatus (100) according to any one of claims 1 to 10, **characterised in that** the projecting elements (5) for fixing counterweight elements (17) are arranged around the tubular body (6) of the mast receiving module and are formed by elements for fixing panels which, when fixed to the projecting elements (5), form a self-supporting structure having a closed perimeter on the base plate (1) susceptible of depositing within said perimeter a material or materials, the weight of which constitutes the counterweight elements (17).

50

55

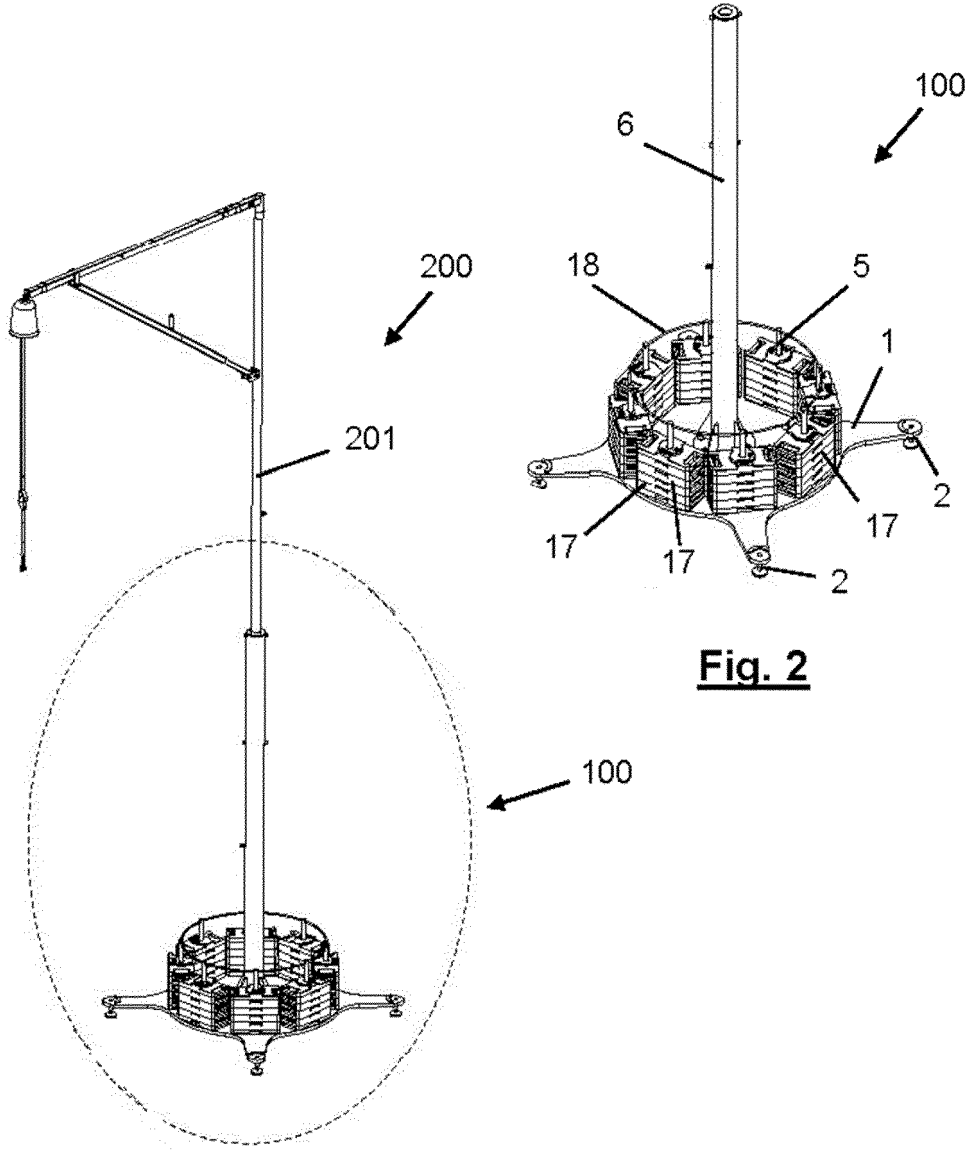

Fig. 1

Fig. 2

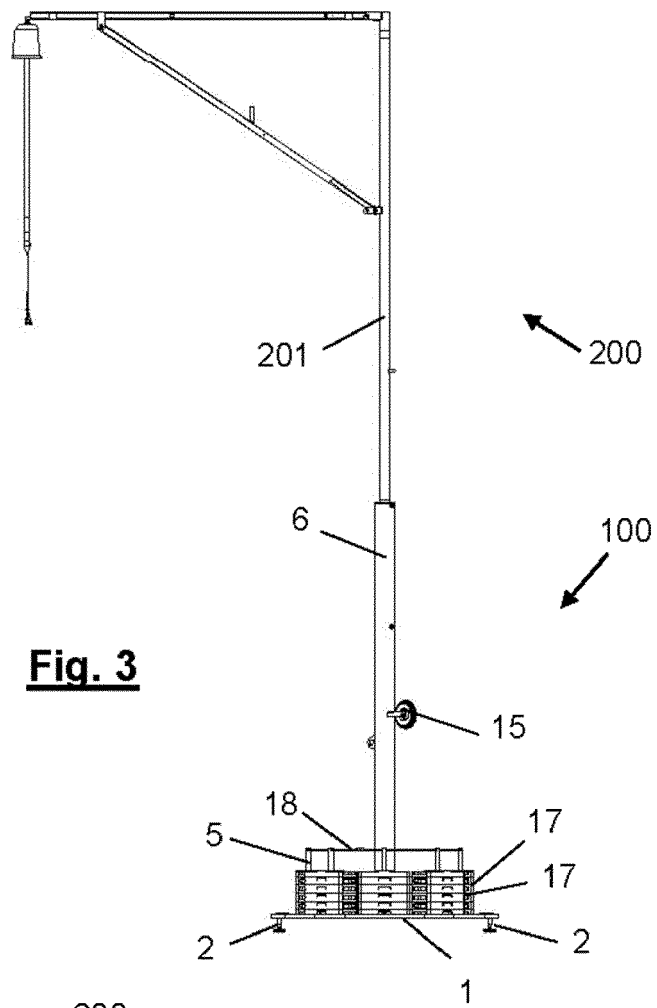

Fig. 3

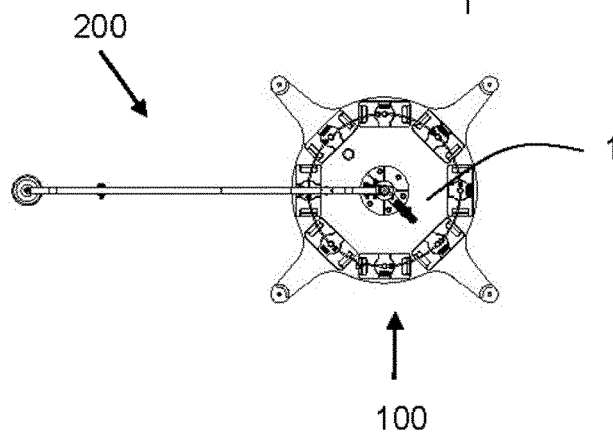

Fig. 4

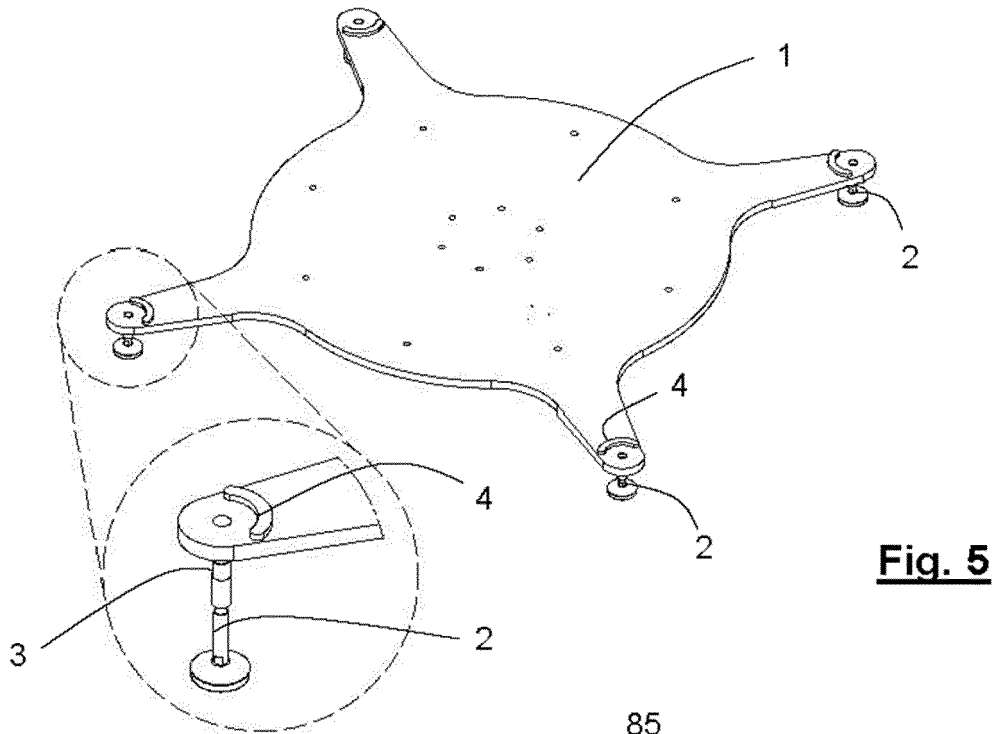

Fig. 5

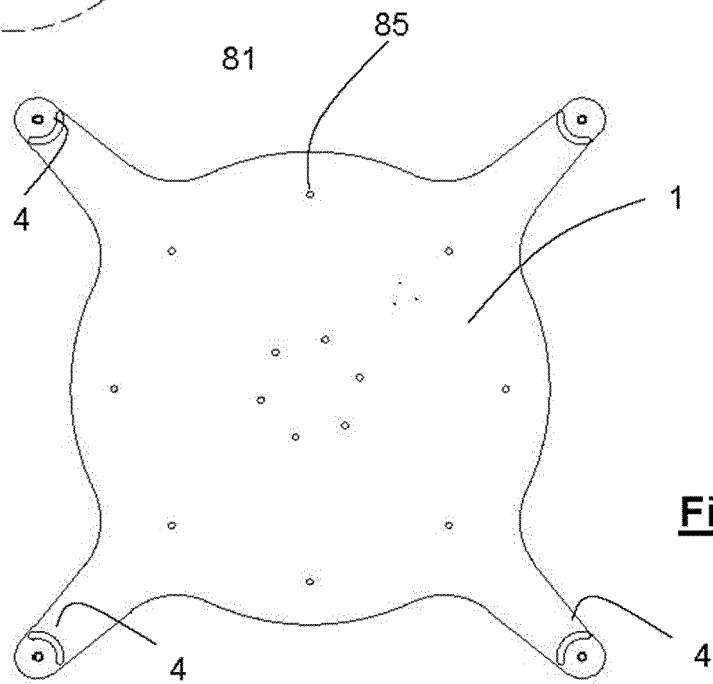

Fig. 6

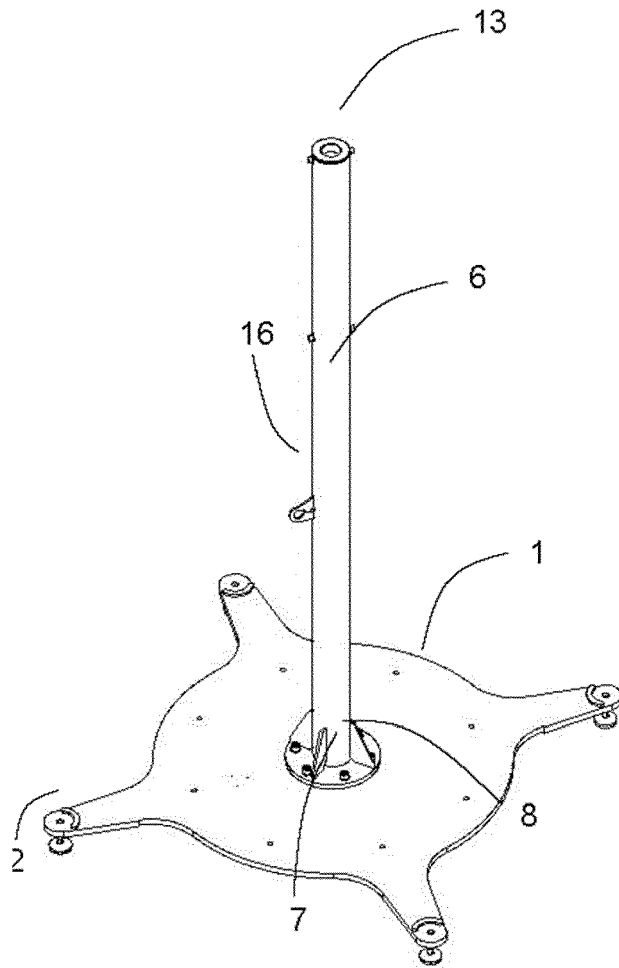

Fig. 7

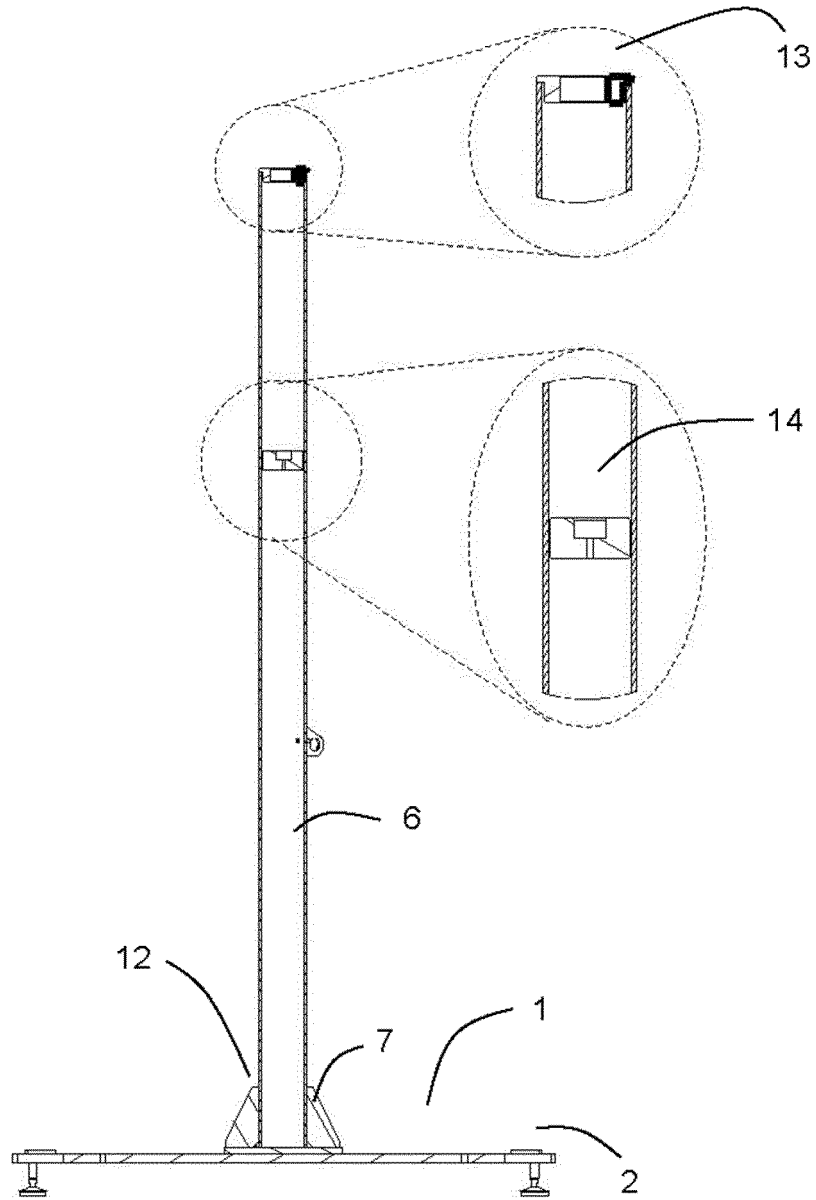

Fig. 8

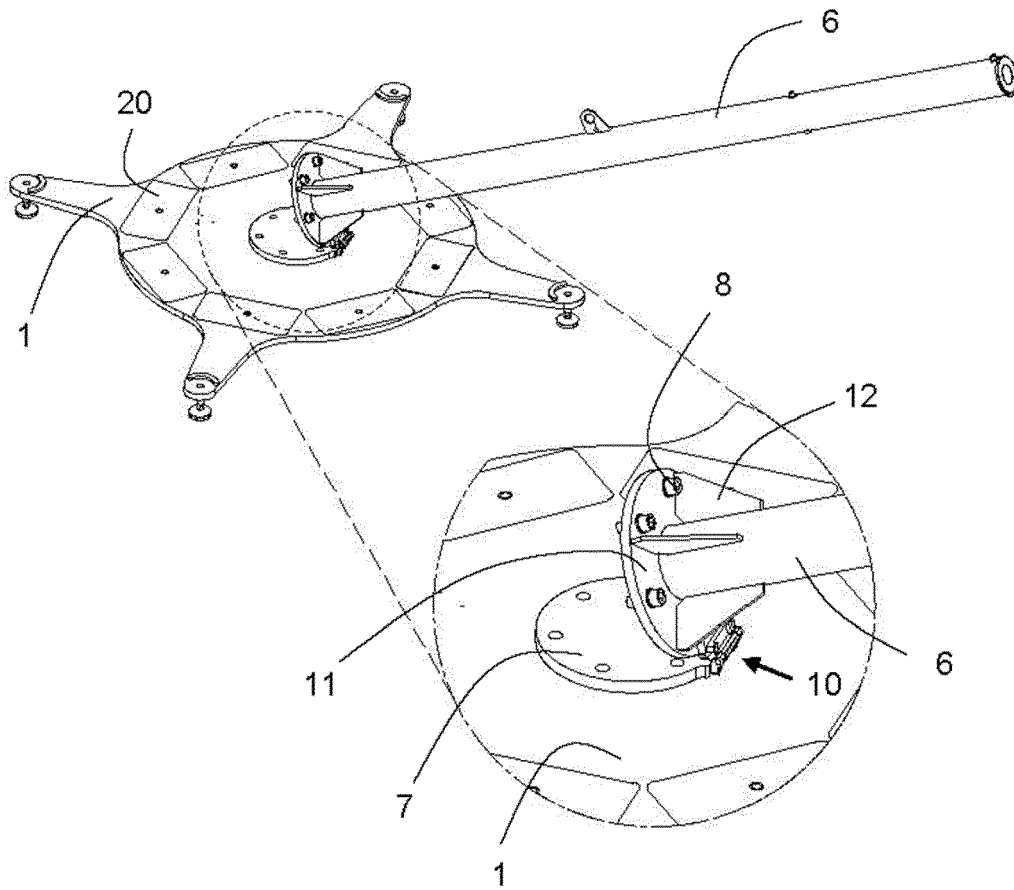

Fig. 9

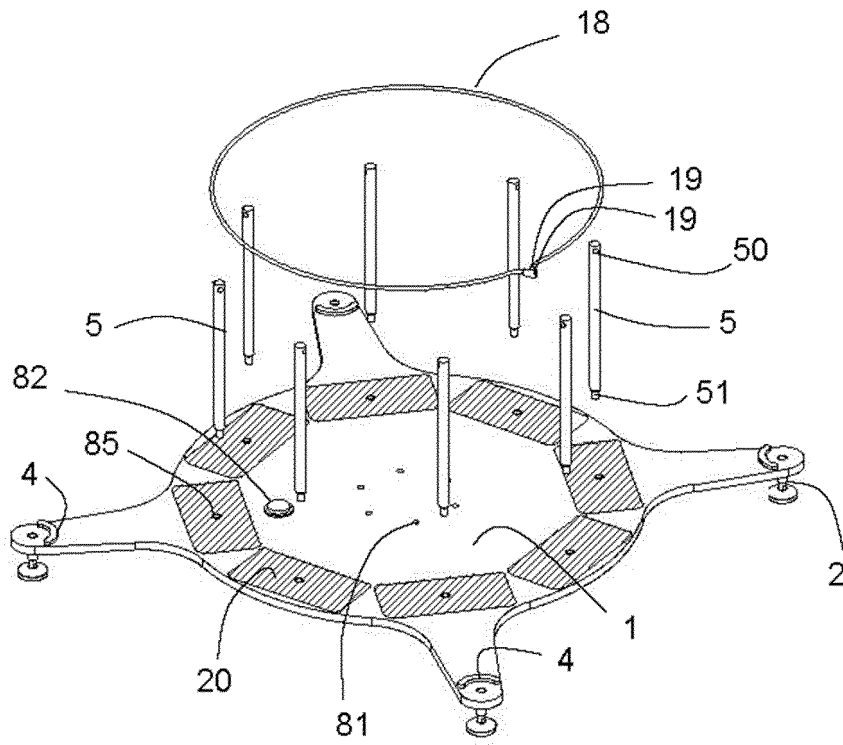

Fig. 10

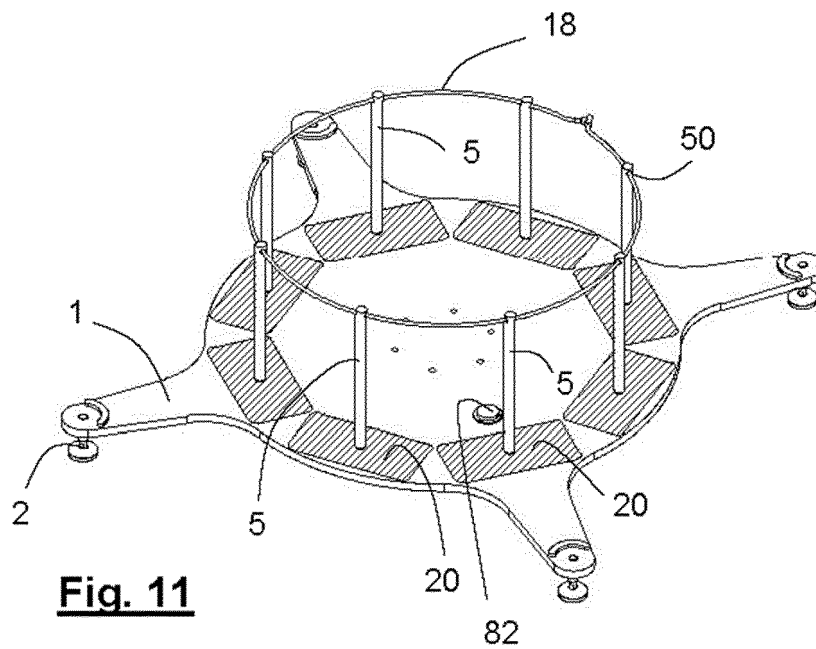

Fig. 11

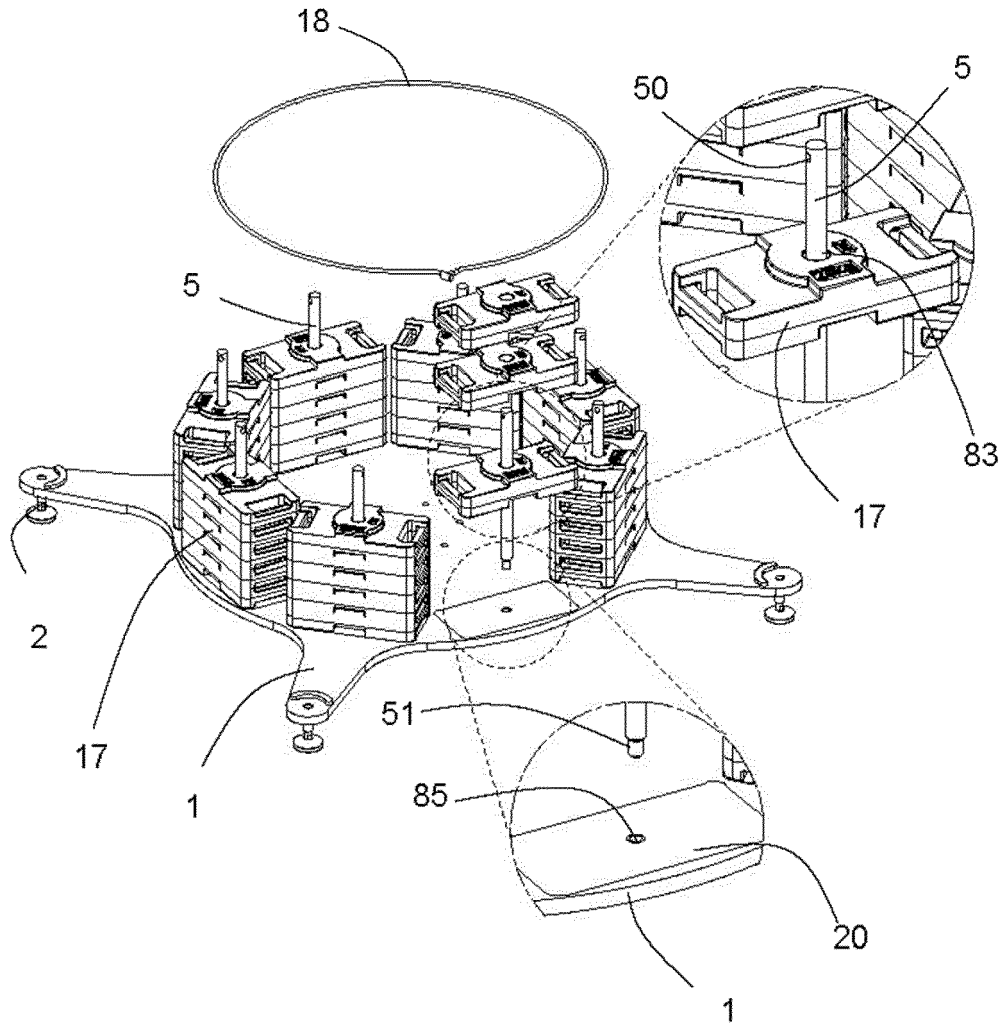

Fig. 12

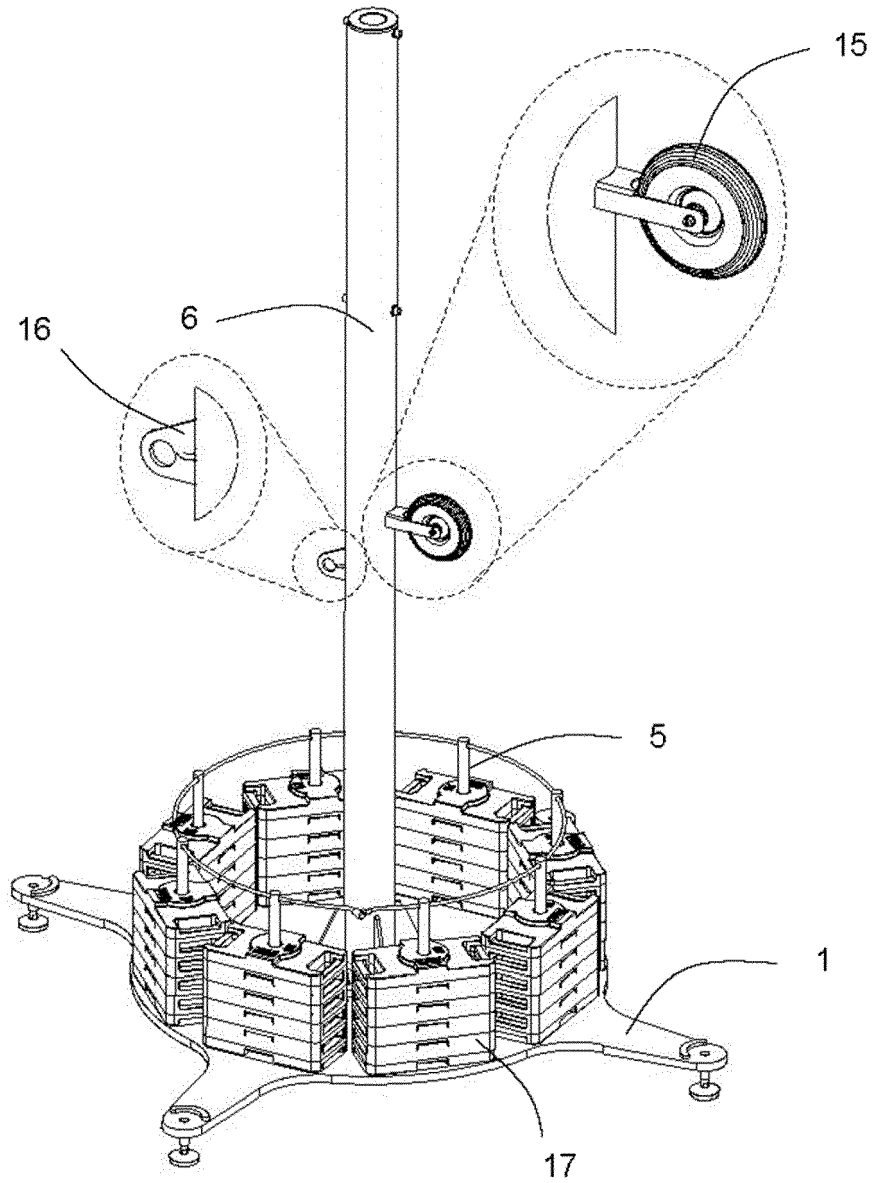

Fig. 13



EUROPEAN SEARCH REPORT

Application Number
EP 19 38 2635

5

10

15

20

25

30

35

40

45

50

55

DOCUMENTS CONSIDERED TO BE RELEVANT			
Category	Citation of document with indication, where appropriate, of relevant passages	Relevant to claim	CLASSIFICATION OF THE APPLICATION (IPC)
X	GB 2 330 169 A (DUNN & COWE LTD [GB]; CRAWFORD HARRY [GB]) 14 April 1999 (1999-04-14) * page 13, line 22 - page 14, line 17; figures *	1-15	INV. A62B35/00
A	----- WO 2017/203349 A1 (CDR ITALY S R L [IT]) 30 November 2017 (2017-11-30) * page 12, line 26 - page 13, line 6; figures * -----	1-15	
			TECHNICAL FIELDS SEARCHED (IPC)
			A62B
The present search report has been drawn up for all claims			
Place of search The Hague		Date of completion of the search 15 January 2020	Examiner Vervenne, Koen
CATEGORY OF CITED DOCUMENTS X : particularly relevant if taken alone Y : particularly relevant if combined with another document of the same category A : technological background O : non-written disclosure P : intermediate document		T : theory or principle underlying the invention E : earlier patent document, but published on, or after the filing date D : document cited in the application L : document cited for other reasons & : member of the same patent family, corresponding document	

EPO FORM 1503 03/82 (P04/C01)

**ANNEX TO THE EUROPEAN SEARCH REPORT
ON EUROPEAN PATENT APPLICATION NO.**

EP 19 38 2635

5 This annex lists the patent family members relating to the patent documents cited in the above-mentioned European search report.
The members are as contained in the European Patent Office EDP file on
The European Patent Office is in no way liable for these particulars which are merely given for the purpose of information.

15-01-2020

10

Patent document cited in search report	Publication date	Patent family member(s)	Publication date
GB 2330169 A	14-04-1999	NONE	

WO 2017203349 A1	30-11-2017	EP 3478370 A1	08-05-2019
		US 2019299036 A1	03-10-2019
		WO 2017203349 A1	30-11-2017

15

20

25

30

35

40

45

50

55

EPO FORM P0459

For more details about this annex : see Official Journal of the European Patent Office, No. 12/82

REFERENCES CITED IN THE DESCRIPTION

This list of references cited by the applicant is for the reader's convenience only. It does not form part of the European patent document. Even though great care has been taken in compiling the references, errors or omissions cannot be excluded and the EPO disclaims all liability in this regard.

Patent documents cited in the description

- EP 1400642 B1 [0004]
- EP 3002044 A1 [0005]
- ES 2639164 T3 [0006]