

(19)



(11)

EP 3 789 721 A1

(12)

EUROPEAN PATENT APPLICATION

(43) Date of publication:
10.03.2021 Bulletin 2021/10

(51) Int Cl.:
F28F 9/02 (2006.01)

(21) Application number: **19461579.5**

(22) Date of filing: **09.09.2019**

(84) Designated Contracting States:
AL AT BE BG CH CY CZ DE DK EE ES FI FR GB GR HR HU IE IS IT LI LT LU LV MC MK MT NL NO PL PT RO RS SE SI SK SM TR
 Designated Extension States:
BA ME
 Designated Validation States:
KH MA MD TN

- **BUREK, Dariusz**
32 050 SKAWINA (PL)
- **JURKIEWICZ, Damian**
32 050 SKAWINA (PL)
- **SZOSTEK, Dawid**
32 050 SKAWINA (PL)

(71) Applicant: **Valeo Autosystemy SP. Z.O.O.**
32-050 Skawina (PL)

(74) Representative: **Bialkowski, Adam**
Valeo Systèmes Thermiques
Industrial Property Department
ZA L'Agot
8 rue Louis Lormand
CS 80517 LA VERRIERE
78322 Le Mesnil Saint Denis Cedex (FR)

(72) Inventors:
 • **BARUS, Lukasz**
32 050 SKAWINA (PL)

(54) **A HEADER-TANK ASSEMBLY**

(57) The header-tank assembly includes a tank, a header a sealing element. The tank includes foot portions configured on at least one pair of opposite sides thereof. The header includes tabs configured on at least one pair of opposite sides. The tabs are crimped along fold lines configured thereon to receive the respective foot portions of the tank and configure connection between the header

and the tank. The sealing element is disposed between the foot portions of the tank and the header. A notch is configured on an outside wall of each tab, wherein the notch extends along the fold line to facilitate crimping of the tabs over the respective foot portions and is visible after crimping operation.

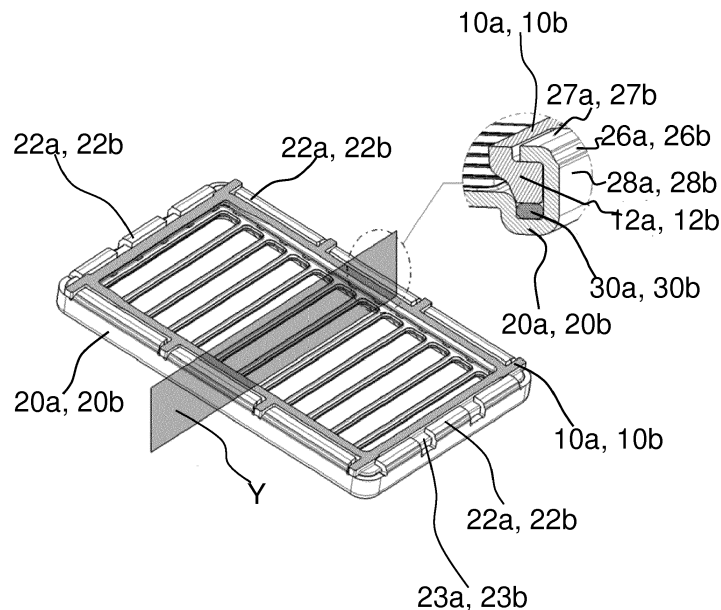

FIG. 2c

EP 3 789 721 A1

Description

[0001] The present invention relates to a heat exchanger, more particularly, to a header-tank assembly for the heat exchanger.

[0002] A heat exchanger generally includes a pair of spaced apart headers connected to two distant and opposite end portions of a heat exchanger core that is received inside a housing. Specifically, each of the spaced apart headers is configured with slots for receiving end portions of heat exchange tubes that along with the fins configure the heat exchanger core. Further, the pair of spaced apart headers, hereinafter referred to as headers are also connected to the end portions of the housing either by welding or brazing or any other joining process. The heat exchanger further includes a pair of heat exchanger tanks, hereinafter referred to as tanks, wherein each tank is joined to the corresponding header for configuring a sealed connection between the headers and the corresponding tanks, thereby configuring a header-tank assembly. Generally, the headers are connected to the respective tanks by crimping. The tank receives first heat exchanging fluid, often pressurized heat exchanging fluid from a first inlet, the heat exchanging fluid traverses through the heat exchange tubes and is received in the tank. The tank delivers out the first heat exchange fluid through a first outlet. The tanks are connected to the headers by crimping. The tanks in conjunction with the corresponding headers facilitate distribution of first heat exchange fluid to and collection of first heat exchange fluid from the heat exchange core. The crimping between the headers and the respective tanks is used for configuring header tank assembly for different heat exchangers such as for example, Water charge Air-cooler, radiator, condenser and evaporator. In case of Water charge Air-cooler, the housing receives second heat exchange media, for example, coolant therein and around the heat exchange tubes through at least one second inlet. The second heat exchange media or coolant is delivered out of the housing through at least one second outlet after the coolant has extracted heat from the first heat exchange fluid flowing through the heat exchange tubes.

[0003] Generally, the headers of the header-tank assembly are provided with tabs that fold along fold lines for facilitating crimping of the tabs of the headers over respective foot portions of the tanks with sealing elements disposed between the headers and the respective foot portions of the tanks. The crimping between the headers and the corresponding tanks is required to be secure in order to configure leak-proof connection between the headers and the corresponding tanks. Generally, the headers are formed of aluminum. In case the tabs of the headers are thick sectioned, comparative more crimping force is required for crimping the tabs over the respective foot portions of the tanks as compared to when the tabs are thin sectioned. The higher crimping forces may damage the tabs or the crimping tool used

for crimping the tabs over the respective foot portions of the tank. The higher crimping forces may also damage the tanks, particularly, in case the tanks are of plastic material. Due to crimping of the tabs over the respective foot portions, cracks and defects may be formed over the tabs, however, these cracks and defects may go unnoticed and aggravate over time resulting in mechanical failures, thereby reducing reliability and service life of the heat exchanger.

[0004] Accordingly, there is a need for a header-tank assembly with a header having a provision for weakening the tabs along fold lines to facilitate crimping of thick sectioned tabs of the header over the foot portion of the respective tank. Further, there is a need for a header-tank assembly with header that requires comparatively less force for crimping of the tabs of the header over foot portions of the respective tank, thereby reducing chances of damage to the tabs or the crimping tool used for crimping or damage to the tanks. Furthermore, there is a need for header-tank assembly with header that not only prevents formation of cracks or defects resulting due to crimping of tabs of the header over foot portion of the respective tank but also ensures quick detection of the cracks or defects just by visual inspection, in case the cracks or defects are formed.

[0005] An object of the present invention is to provide a header-tank assembly with a header that obviates drawbacks associated with conventional headers that do not have any provision for weakening tabs along fold lines to facilitate crimping of the headers on respective tanks and as such the tabs are prone to damage, cracks and defects due to being subjected to high crimping forces during crimping.

[0006] Another object of the present invention is to provide a header-tank assembly with a header of such configuration that requires comparatively less force for crimping of tabs configured on the header over foot portions of respective tank.

[0007] Further, object of the present invention is to provide a header-tank assembly with a header of such configuration that substantially reduces forces required for crimping tabs configured on the headers over foot portion of respective tanks, thereby preventing damage to crimping tool used for crimping and extending service life of the crimping tool.

[0008] Another object of the present invention is to provide a header tank assembly with header of such configuration that prevents damage to the tank, particular tank of plastic material.

[0009] Still another object of the present invention is to provide a header-tank assembly with a header of such configuration that prevents formation of cracks or defects resulting due to crimping of tabs configured on the header over foot portion of the respective tanks.

[0010] Yet another object of the present invention is to provide a header-tank assembly with a header of such configuration that facilitates quick and easy detection of cracks or defects formed on the header just by visual

inspection, in case any cracks or defects are formed.

[0011] In the present description, some elements or parameters may be indexed, such as a first element and a second element. In this case, unless stated otherwise, this indexation is only meant to differentiate and name elements which are similar but not identical. No idea of priority should be inferred from such indexation, as these terms may be switched without betraying the invention. Additionally, this indexation does not imply any order in mounting or use of the elements of the invention.

[0012] A header-tank assembly is disclosed in accordance with an embodiment of the present invention. The header-tank assembly includes a tank, a header a sealing element. The tank includes foot portions configured on at least one pair of opposite sides thereof. The header includes tabs configured on at least one pair of opposite sides. The tabs are crimped along fold lines configured thereon to receive the respective foot portions of the tank and configure connection between the header and the tank. The sealing element is disposed between the foot portions of the tank and the header. A notch is configured on an outside wall of each tab, wherein the notch extends along the fold line to facilitate crimping of the tabs over the respective foot portions and is visible after crimping operation.

[0013] Generally, at least one tab is configured on each side of at least one pair of opposite sides of the header.

[0014] Particularly, the tabs configured on each side of at least one pair of opposite sides of the header are spaced apart from each other.

[0015] Specifically, the tabs fold along the fold lines and the notches extending along top edges of the foot portions of the tank received in the respective header to define the crimped configuration of the tabs.

[0016] More specifically, the tabs in the crimped configuration thereof receives the respective foot portions of the tank such that a first portion and a second portion of the tabs connected along the notch abut against edges of the foot portions of the tank.

[0017] Generally, the thickness of each tab along the notch is reduced by 10-35 percent as compared to thickness of rest of the tab.

[0018] A heat exchanger is disclosed in accordance with an embodiment of the present invention. The heat exchanger includes a pair of spaced apart header-tank assembly connected by a plurality of heat exchanger elements, wherein a first header-tank assembly facilitates distribution of heat exchange fluid to the heat exchanger elements, whereas a second header-tank assembly disposed opposite to and spaced away from the first header-tank assembly facilitates collection of heat exchange fluid from the heat exchanger elements. The at least one of the header-tank assembly of the pair of header-tank assembly includes a tank, a header and a sealing element. The tank includes foot portions configured on at least one pair of opposite sides thereof. The header includes tabs configured on at least one pair of opposite sides thereof. The tabs are crimped along fold lines configured thereon

to receive respective foot portions of the tank and configure connection between the header and the tank. The sealing element is disposed between the foot portions of the tank and the header. A notch is configured on an outside wall of each tab, wherein the notch extends along the fold line to facilitate crimping of the tabs over the respective foot portions and is visible even after the crimping operation.

[0019] Other characteristics, details and advantages of the invention can be inferred from the description of the invention hereunder. A more complete appreciation of the invention and many of the attendant advantages thereof will be readily obtained as the same becomes better understood by reference to the following detailed description when considered in connection with the accompanying figures, wherein:

FIG. 1a illustrates a heat exchanger in accordance with the prior art;

FIG. 1b illustrates a header-tank assembly of the heat exchanger of **FIG. 1a**, wherein tabs of a header of the header-tank assembly are depicted in uncrimped configuration, also, is depicted an enlarged sectional view of the header-tank assembly along sectional plane X;

FIG. 1c illustrates a header-tank assembly of the heat exchanger of **FIG. 1a**, wherein tabs of a header of the header-tank assembly are depicted in crimped configuration, also is depicted an enlarged sectional view of the header-tank assembly along sectional plane X;

FIG. 2a illustrates a heat exchanger in accordance with the present invention;

FIG. 2b illustrates a header-tank assembly of the heat exchanger of **FIG. 2a**, wherein tabs of a header of the header-tank assembly are depicted in uncrimped configuration, also is depicted an enlarged sectional view of the header-tank assembly along sectional plane Y;

FIG. 2c illustrates a header-tank assembly of the heat exchanger of **FIG. 2a**, wherein tabs of a header of the header-tank assembly are depicted in crimped configuration, also is depicted an enlarged sectional view of the header-tank assembly along sectional plane Y;

[0020] It must be noted that the figures disclose the invention in a detailed enough way to be implemented, said figures helping to better define the invention if needs be. The invention should however not be limited to the embodiment disclosed in the description.

[0021] Although, the present invention relates to a header of a heat exchanger used in automobiles that is

configured with tabs of such configuration that facilitate crimping of the tank over the header, without requiring much effort and without damaging the crimping tool and also reducing the chances of damage, cracks and defects caused to the header due to the header being subjected to high crimping forces during crimping. Further, the header of the heat exchanger is of such configuration that even in case damage, cracks and defects are formed on the header, these are visible from outside and can be detected just by visual inspection. However, the present invention is applicable to any assembly used in any application and that is configured by crimping one part over the other.

[0022] FIG. 1a illustrates a conventional heat exchanger 01. The heat exchanger 01 generally includes a pair of spaced apart headers 02a and 02b, simply referred to as headers 02a and 02b connected to two distant and opposite end portions of a heat exchanger core received inside a housing 06. Specifically, each of the spaced apart headers 02a and 02b is configured with slots for receiving end portions of heat exchange tubes that configure the heat exchanger core along with the fins. Further, the headers 02a and 02b are also connected to the end portions of the housing 06 either by welding or brazing or any other joining process. The heat exchanger 01 further includes a pair of heat exchanger tanks 04a and 04b, hereinafter referred to as tanks, wherein each tank 04a, 04b is joined to the corresponding header 02a, 02b for configuring a sealed connection between the headers 02a, 02b and the corresponding tanks 04a, 04b, thereby forming a header-tank assembly 09a, 09b. Generally, the headers 02a and 02b are connected to the respective tanks 04a and 04b by crimping. The tank 04a receives first heat exchanging fluid, often pressurized heat exchanging fluid from a first inlet 07a and the other tank 04b delivers out the first heat exchange fluid through a first outlet 07b. The tanks 04a and 04b in conjunction with the corresponding headers 02a and 02b facilitate distribution of first heat exchange fluid to and collection of first heat exchange fluid from the heat exchange core 03. The housing 06 receives second heat exchange media, particularly coolant therein and around the heat exchange tubes through at least one second inlet. The second heat exchange media or coolant is delivered out of the housing 06 through at least one second outlet after the coolant has extracted heat from the first heat exchange fluid flowing through the heat exchange tubes.

[0023] Generally, the headers 02a, 02b of the header-tank assembly 09a, 09b are provided with tabs 03a, 03b respectively. The tabs 03a, 03b fold along the fold lines 08a, 08b for facilitating crimping of the headers 02a, 02b over respective foot portions 05a, 05b of the tanks 04a, 04b with sealing elements 11a, 11b disposed between the headers 02a, 02b and the respective foot portions 05a, 05b of the tanks 04a, 04b. FIG. 1b illustrates the header-tank assembly 09a, 09b of the heat exchanger 01, wherein the tabs 03a, 03b are depicted in un-crimped configuration, also is depicted an enlarged sectional view

of the header-tank assembly 09a, 09b along sectional plane X with the tabs 03a, 03b in un-crimped configuration. FIG. 1c illustrates the header-tank assembly 09a, 09b of the heat exchanger 01, wherein the tabs 03a, 03b are depicted in crimped configuration, also is depicted an enlarged sectional view of the header-tank assembly 09a, 09b along sectional plane X with the tabs 03a, 03b in crimped configuration. The crimping between the headers 02a, 02b and the corresponding tanks 04a, 04b is required to be secure in order to configure leak-proof connection between the headers 02a, 02b and the corresponding tanks 04a, 04b. The sealing elements 11a, 11b provide sealing connection between the headers 02a, 02b and the respective tanks 04a, 04b. Generally, the headers 02a, 02b are formed of aluminum. In case the tabs 03a, 03b of the headers 02a, 02b are thick sectioned, comparative more crimping force is required for crimping the tabs 03a, 03b over the respective foot portions 05a, 05b of the tanks 04a, 04b. The higher crimping forces may damage the tabs 03a, 03b or the crimping tool used for crimping the tabs 03a, 03b configured on the headers 02a, 02b over the respective foot portions 05a, 05b of the tanks 04a, 04b.

[0024] In order to facilitate easy crimping of the tabs 03a, 03b configured on the headers 02a, 02b over the respective foot portions 05a, 05b of the tanks 04a, 04b, the tabs 03a, 03b may be weakened along the fold lines 08a, 08b by providing notches along inside wall of the tabs 03a, 03b as illustrated in FIG. 1b. The tabs 03a, 03b with notches along inside wall thereof are comparatively more prone to cracks, defects and damages due to space restrictions. Also, if cracks or defects are formed along the notches due to crimping, these are not visible once the tabs 03a, 03b are crimped over the respective foot portions 05a, 05b of the tank 04a, 04b. Accordingly, such cracks and defects may go un-noticed and get aggravated over time resulting in mechanical failures, thereby reducing reliability and service life of the heat exchanger 01. Therefore, there is need of a heat exchanger with header 02a, 02b of such configuration that permits detection of damage, cracks and defects of the header 02a, 02b just by visual inspection, thereby avoiding severe mechanical failure of the heat exchanger 01 due to aggravation of the damage, cracks and defects because of these damages, cracks and defects remaining concealed and unnoticed.

[0025] FIG. 2a illustrates a heat exchanger 200 in accordance with an embodiment of the present invention. The heat exchanger 200 includes a pair of spaced apart header-tank assembly 100a and 100b connected by a plurality of heat exchanger elements 40a that forms a part of a heat exchanger core 40 along with the fin elements disposed between the heat exchanger elements 40a. A first header-tank assembly 100a of the pair of header-tank assembly 100a and 100b facilitates distribution of heat exchange fluid to the heat exchanger elements 40a, particularly, the heat exchanger tubes. A second header-tank assembly 100b of the pair of header-

tank assembly **100a** and **100b** disposed opposite to and spaced away from the first header-tank assembly **100a** facilitates collection of heat exchange fluid from the heat exchanger elements **40a**, particularly, the heat exchanger tubes.

[0026] The header-tank assembly **100a** is disclosed in accordance with an embodiment of the present invention. As the first and the second header-tank assemblies **100a** and **100b** are identical in structure, every embodiment disclosed henceforth for the header-tank assembly **100a** and the elements configuring the header-tank assembly **100a** may also be applicable for the header-tank assembly **100b** and elements configuring the header-tank assembly **100b**. For sake of brevity of present document, the first header-tank assembly **100a** is only elaborately described in the below description.

[0027] The first header-tank assembly **100a** includes a tank **10a**, a header **20a** and a sealing element **30a**. The tank **10a** includes foot portions **12a** configured on at least one pair of opposite sides of the tank **10a**. The header **20a** includes tabs **22a** configured on at least one pair of opposite sides thereof. More specifically, the tabs **22a** are configured on the opposite sides of the header **20a** that are complementary to the opposite sides of the tank **10a** on which the foot portions **12a** are configured. The tabs **22a** are crimped along fold lines **24a** configured thereon to receive the respective foot portions **12a** of the tank **10a** and configure connection between the header **20a** and the tank **10a**. In accordance with an embodiment of the present invention, at least one tab **22a** is configured on each side of at least one pair of opposite sides of the header **20**. In one example, each side of the header **20a** includes three tabs configured thereon as illustrated in **FIG. 2b**. In case there are more than one tab **22a** on each side of the at least one pair of opposite sides of the header **20a**, then the tabs **22a** are spaced apart from each other by spacing **23a** between the adjacent tabs **22a** as illustrated in **FIG. 2b** and **FIG. 2c**. However, the present invention is not limited to any particular number, placement, spacing between the tabs **22a** as far as the tabs **22a** are capable of receiving the respective foot portions **12a** of the tank **10a** to configure connection between the header **20a** and the tank **10a**. The sealing element **30a** is disposed between the foot portions **12a** of the tank **10a** and the header **20a** and configures a sealing connection between the header **20a** and the tank **10a**. In accordance with an embodiment of the present invention, the sealing element **30a** is in form of a continuous closed loop. However, the present invention is not limited to any particular number, placement and configuration of the sealing element **30a** as far as the sealing element **30a** configures sealing connection between the header **20a** and the tank **10a**.

[0028] A notch **26a** is configured on an outside wall of each of the tabs **22a** configured on the header **20a**, wherein the notch **26a** extends along the fold lines **24a** to facilitate crimping of the tabs **22a** over the respective foot portions **12a** of the tanks **10a**, while still being visible

even after the crimping operation. Specifically, the notches **26a** configured on the tabs **22a** facilitate weakening the tabs **22a** along fold lines to facilitate crimping of even thick sectioned tabs **22a** of the header **20a** over the foot portions **12a** of the respective tank **10a** along the fold lines **24a**. More specifically, the thickness of the tabs **22a** along the notch **26a** is reduced by 10-35 percent as compared to thickness of rest of the tabs **22a**. With such configuration and weakening of the tabs **22a** along the fold lines **24a**, comparatively less force is required for crimping of the tabs **22a** of the header **20a** over the foot portions **12a** of the respective tank **10a**, thereby reducing chances of damage to the tabs **22a** or the crimping tool used for crimping. Further, such configuration of the notches **26a** not only prevents formation of cracks or defects resulting due to crimping of the tabs **22a** of the header **20a** over the foot portion **12a** of the respective tank **10a** but also ensures quick detection of the cracks or defects just by visual inspection, in case the cracks or defects are formed as the cracks or defects are formed near the notches and at the exterior wall of the header **20a**. The tabs **22a** fold along the respective fold lines **24a** and the notches **26a** that are extending along top edges of the foot portions **12a** of the tank **10a** received in the respective header **20a** to define the crimped configuration of the tabs **22a**. The tabs **22a** in the crimped configuration thereof as illustrated in **FIG. 2c**, so receives the respective foot portions **12a** of the tank **10a** that a first portion **27a** and a second portion **28a** of the tabs **22a** connected along the notch **26a** abut against edges of the foot portions **12a** of the tank **10a**. In accordance with an embodiment, the edges of the foot portions **12a** of the tank **10a** are orthogonal to each other, accordingly, the first portion **27a** and the second portion **28a** of the tabs **22a** abutting against the orthogonal edges of the foot portions **12a** of the tank are also orthogonal. In another embodiment, the edges of the foot portions **12a** of the tank **10a** can be at any angle with respect to each other, accordingly, the first portion **27a** and the second portion **28a** of the tabs **22a** abutting against the edges of the foot portions **12a** of the tank **10a** are complementary to the edges. In accordance with an embodiment of the present invention, the notch **26a** extends along the length of each tab **22a** and along the fold line **24a** to facilitate crimping of the tabs **22a** over the respective foot portions **12a**.

[0029] Similar header-tank assembly **100b**, also referred to as the second header-tank assembly **100b** is configured at opposite end portion of the heat exchanger core **40**, wherein the second tank **10b** of the header-tank assembly **100b** is crimped to the corresponding header **20b**. The header-tank assembly **100b** includes a tank **10b**, a header **20b** and a sealing element **30b**. The header **20b** includes tabs **22b** separated by spacing **23b** in case there are multiple tabs **22b** on a single side of the header **20b**. A notch **26b** is configured on an outside wall of each of the tabs **22b**, the notch **26b** extends along the fold line **24b** to facilitate crimping of the tabs **22b** over the respective foot portions **12b** while still being visible

even after the crimping operation. The elements and function of the header-tank assembly **100b** are not elaborately disclosed in the present document for the sake of brevity of the present document.

[0030] Several modifications and improvement might be applied by the person skilled in the art to the heat exchanger and the header-tank assembly thereof as disclosed above and such modifications and improvements will still be considered within the scope and ambit of the present invention, as long as heat exchanger includes a pair of spaced apart header-tank assembly connected by a plurality of heat exchanger elements, wherein the header-tank assembly includes a tank, a header and a sealing element. The tank includes foot portions configured on at least one pair of opposite sides thereof. The header includes tabs configured on at least one pair of opposite sides. The tabs are crimped along fold lines configured thereon to receive respective foot portions of the tank and configure connection between the header and the tank. The sealing element is disposed between the foot portions of the tank and the header. A notch is configured on an outside wall of each tab, wherein the notch extends along the fold line to facilitate crimping of the tabs over the respective foot portions and is visible after crimping operation.

[0031] In any case, the invention cannot and should not be limited to the embodiments specifically described in this document, as other embodiments might exist. The invention shall spread to any equivalent means and any technically operating combination of means.

Claims

1. A header-tank assembly (100a, 100b) comprising:

- a tank (10a, 10b) comprising foot portions (12a, 12b) configured on at least one pair of opposite sides thereof;
- a header (20a, 20b) comprising tabs (22a, 22b) configured on at least one pair of opposite sides thereof, the tabs (22a, 22b) adapted to be crimped along fold lines (24a, 24b) configured thereon to receive the respective foot portions (12a, 12b) of the tank (10a, 10b) and configure connection between the header (20a, 20b) and the tank (10a, 10b);
- a sealing element (30a, 30b) disposed between the foot portions (12a, 12b) of the tank (10a, 10b) and the header (20a, 20b),

characterized in that a notch (26a, 26b) is configured on an outside wall of each tab (22a, 22b), the notch (26a, 26b) extends along the fold line (24a, 24b) to facilitate crimping of the tabs (22a, 22b) over the respective foot portions (12a, 12b).

2. The header-tank assembly (100a, 100b) as claimed

in claim 1, wherein at least one tab (22a, 22b) is configured on each side of at least one pair of opposite sides of the header (20).

3. The header-tank assembly (100a, 100b) as claimed in claim 1, wherein the tabs (22a, 22b) configured on each side of at least one pair of opposite sides of the header (20) are spaced apart from each other.

4. The header-tank assembly (100a, 100b) as claimed in claim 1, wherein the tabs (22a, 22b) are adapted to fold along the respective fold lines (24a, 24b) and the notches (26a, 26b) extending along top edges of the foot portions (12a, 12b) of the tank (10a, 10b) received in the respective header (20a, 20b) to define the crimped configuration of the tabs (22a, 22b) of the headers (20a, 20b).

5. The header-tank assembly (100a, 100b) as claimed in claim 4, wherein the tabs (22a, 22b) in the crimped configuration thereof are adapted to receive the respective foot portions (12a, 12b) of the tanks (10a, 10b) such that a first portion (27a, 27b) and a second portion (28a, 28b) of the tabs (22a, 22b) connected along the notch (26a, 26b) abut against edges of the foot portions (12a, 12b) of the tank (10a, 10b).

6. The header-tank assembly (100a, 100b) as claimed in any of the preceding claims, wherein thickness of each tab (22a, 22b) along the notch (26a, 26b) is reduced by 10-35 percent as compared to the rest of the tab (22a, 22b).

7. A heat exchanger (200) comprising a pair of spaced apart header-tank assembly (100a) and (100b) connected by a plurality of heat exchanger elements (40a), wherein a first header-tank assembly (100a) is adapted to facilitate distribution of heat exchange fluid to the heat exchanger elements (40a), whereas a second header-tank assembly (100b) disposed opposite to and spaced away from the first header-tank assembly (100a) is adapted to facilitate collection of heat exchange fluid from the heat exchanger elements (40a), **characterized in that** at least one of the header-tank assembly of the pair of header-tank assembly (100a, 100b) is according to one of the previous claims.

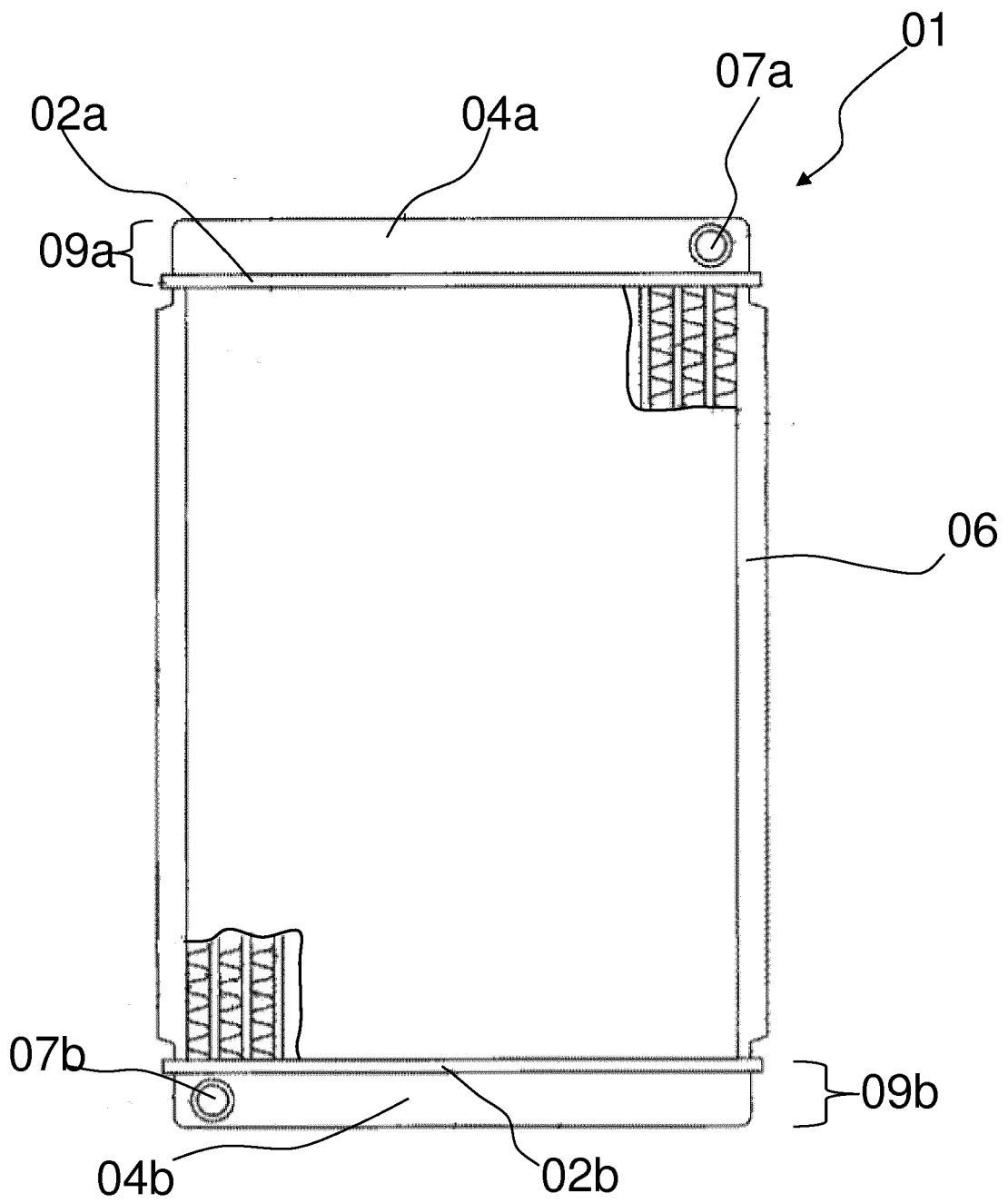

FIG. 1a
(PRIOR ART)

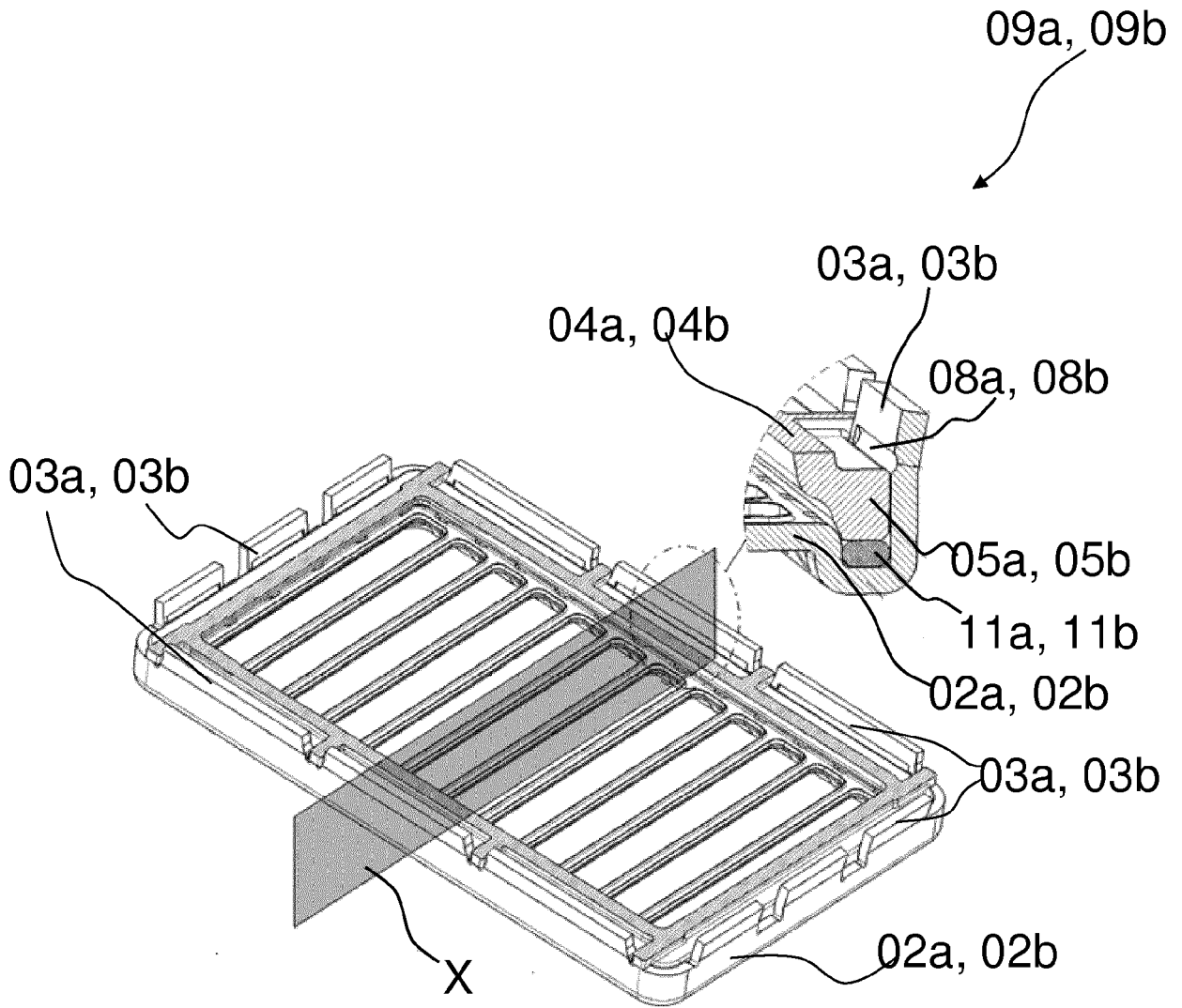

FIG.1b
(PRIOR ART)

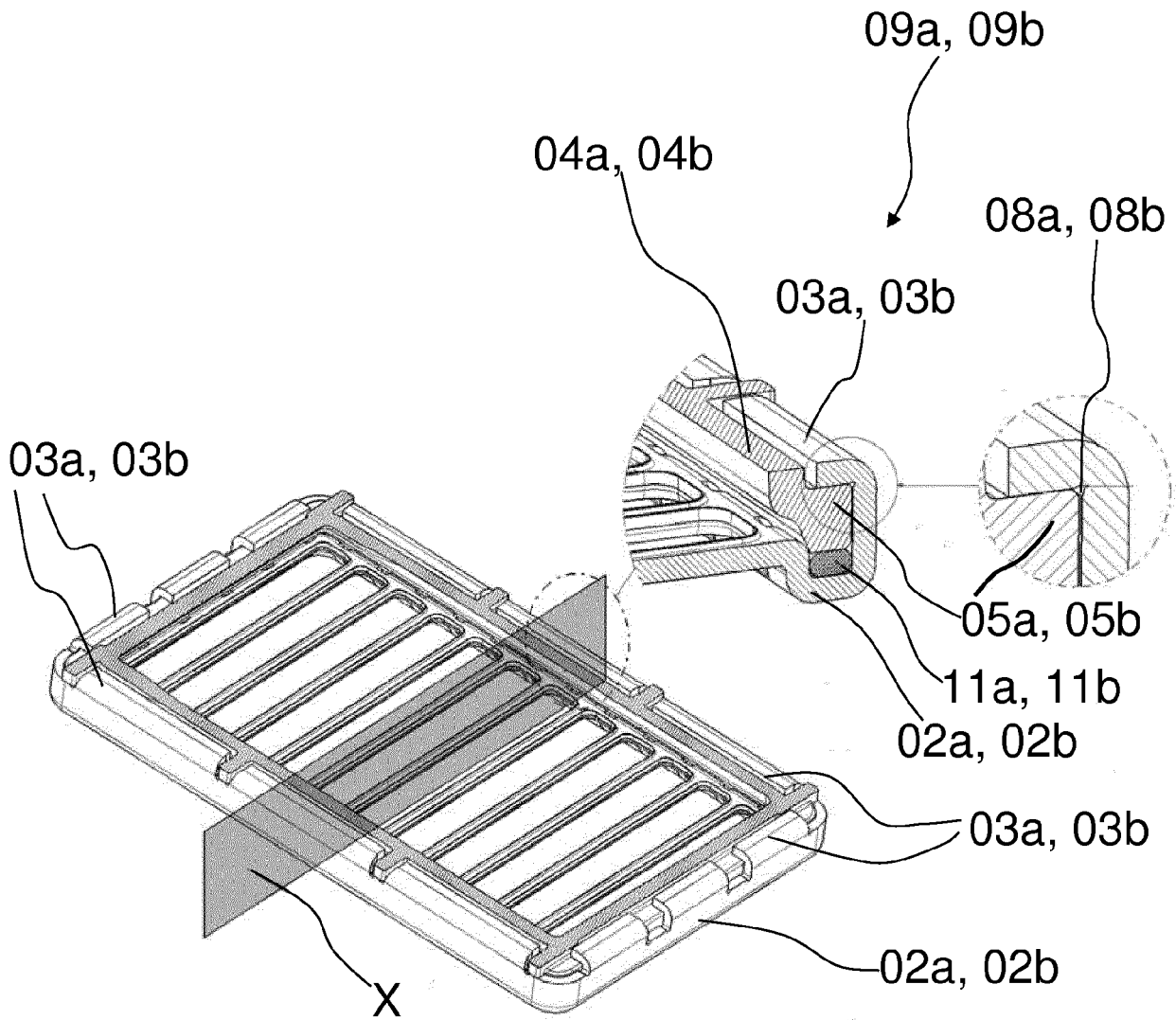

FIG.1c
(PRIOR ART)

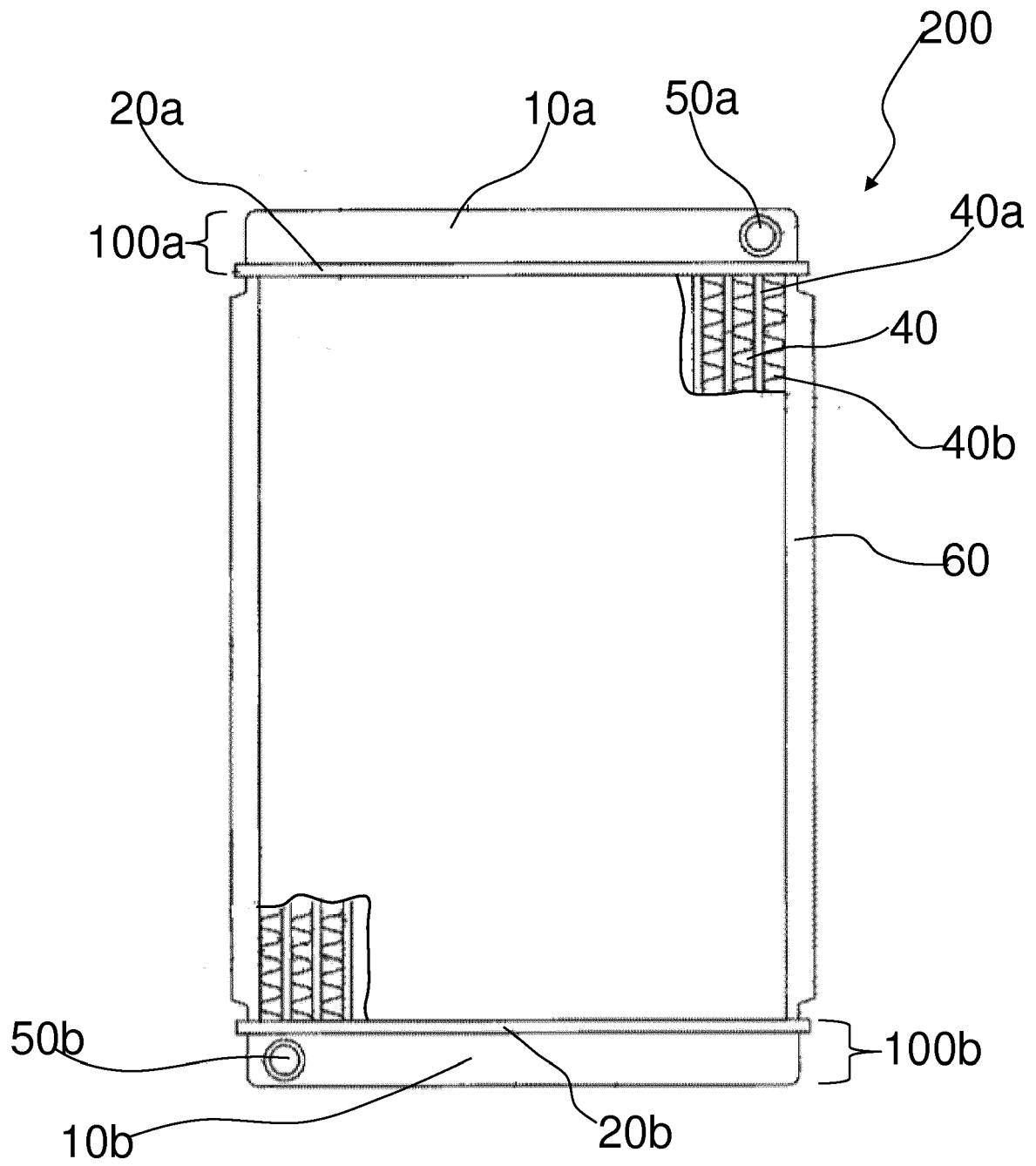

FIG. 2a

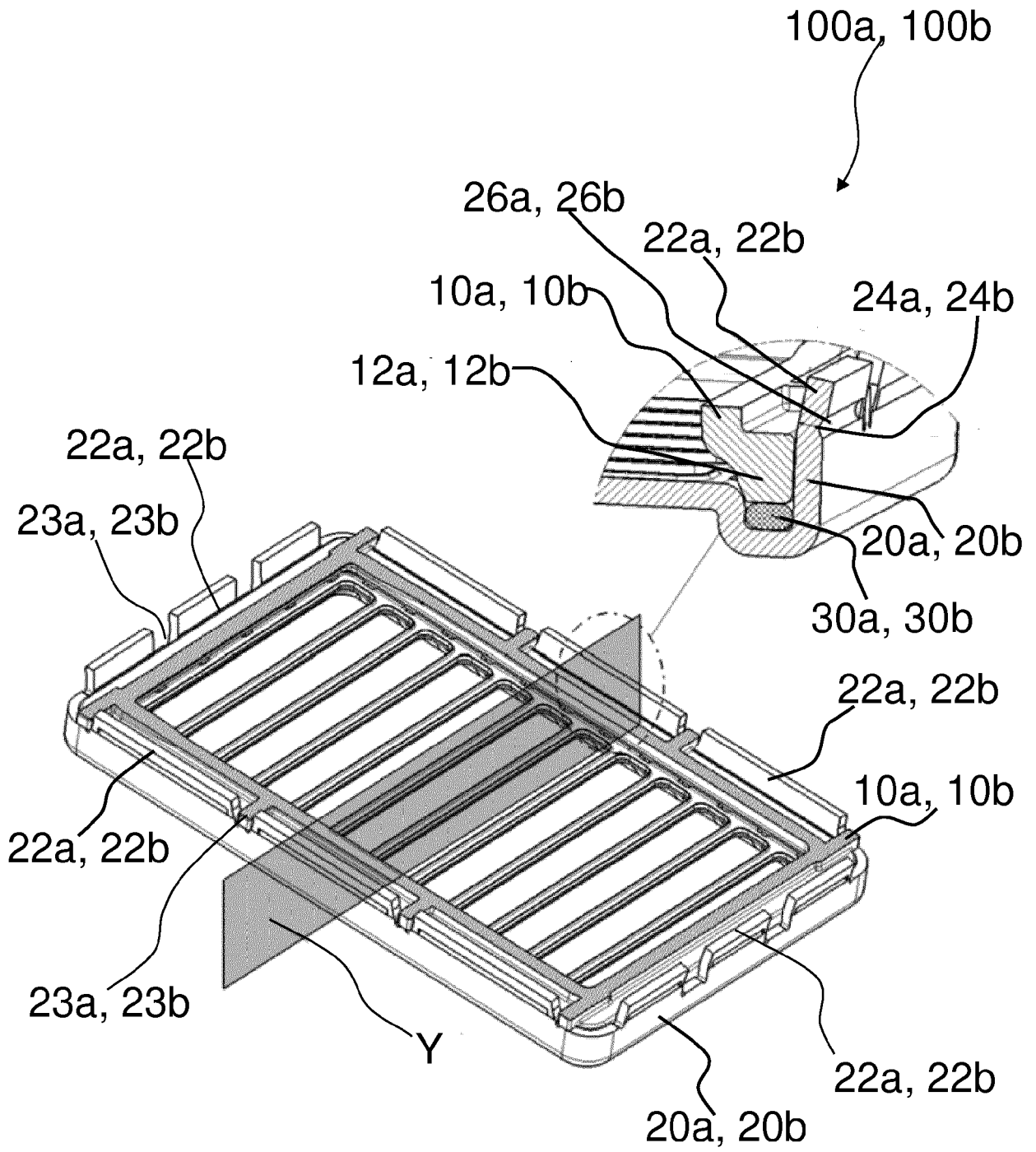

FIG. 2b

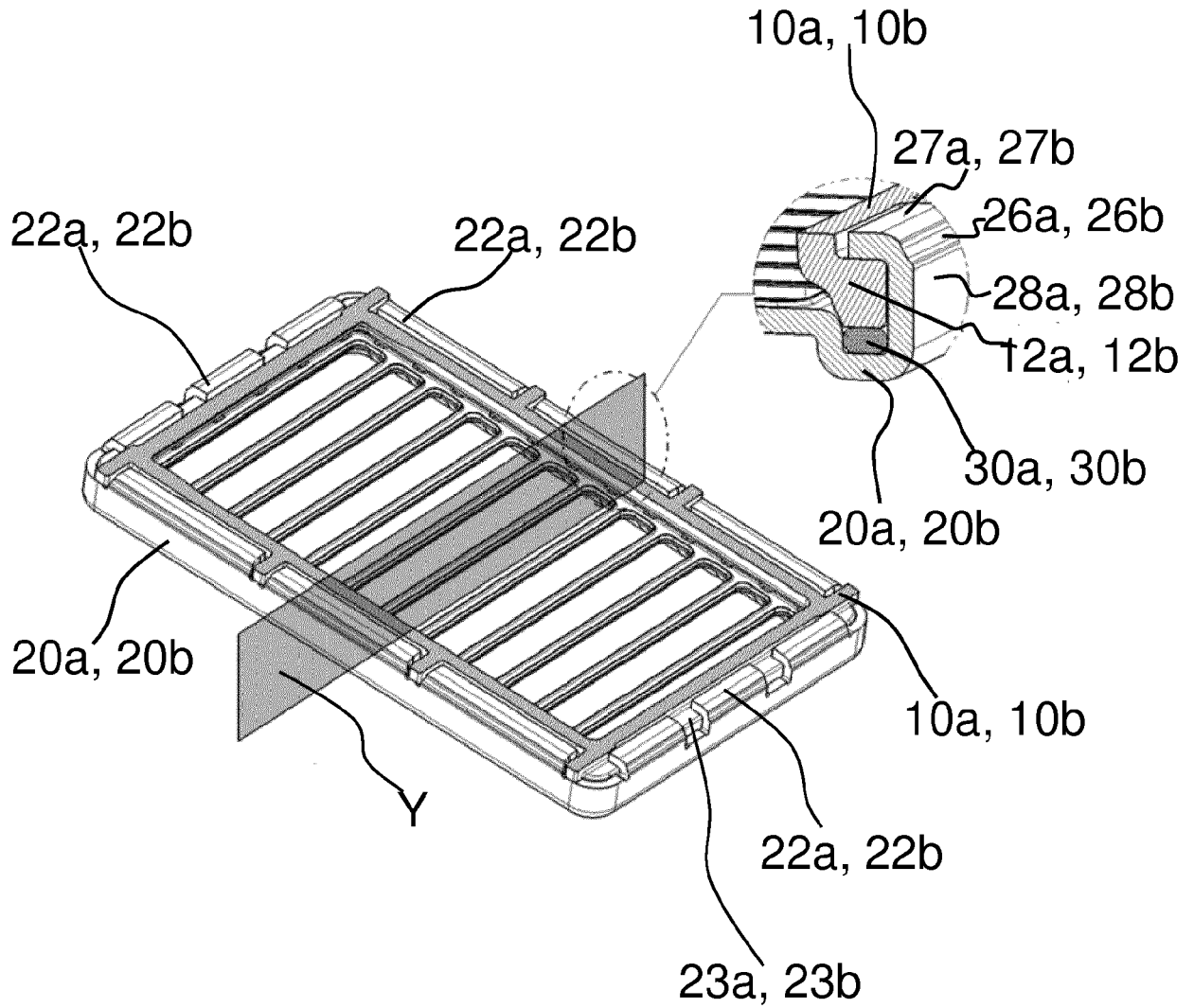

FIG. 2c



EUROPEAN SEARCH REPORT

Application Number
EP 19 46 1579

5

10

15

20

25

30

35

40

45

50

55

DOCUMENTS CONSIDERED TO BE RELEVANT			
Category	Citation of document with indication, where appropriate, of relevant passages	Relevant to claim	CLASSIFICATION OF THE APPLICATION (IPC)
X	US 2002/134529 A1 (NOZAKI TAKAHIRO [JP] ET AL) 26 September 2002 (2002-09-26) * paragraph [0045] - paragraph [0049]; figure 5 *	1-7	INV. F28F9/02
X	JP 2000 249491 A (SANDEN CORP) 14 September 2000 (2000-09-14) * abstract; figure 5a *	1-7	
X	DE 42 43 495 A1 (BEHR GMBH & CO [DE]) 23 June 1994 (1994-06-23) * the whole document *	1	
A	US 2017/299283 A1 (RIONDET CHRISTIAN [FR]) 19 October 2017 (2017-10-19) * abstract; figure 4 *	1-7	
			TECHNICAL FIELDS SEARCHED (IPC)
			F28F
The present search report has been drawn up for all claims			
Place of search Munich		Date of completion of the search 5 March 2020	Examiner Jessen, Flemming
CATEGORY OF CITED DOCUMENTS X : particularly relevant if taken alone Y : particularly relevant if combined with another document of the same category A : technological background O : non-written disclosure P : intermediate document		T : theory or principle underlying the invention E : earlier patent document, but published on, or after the filing date D : document cited in the application L : document cited for other reasons & : member of the same patent family, corresponding document	

1
EPO FORM 1503 03/82 (P04/C01)

ANNEX TO THE EUROPEAN SEARCH REPORT
ON EUROPEAN PATENT APPLICATION NO.

EP 19 46 1579

5 This annex lists the patent family members relating to the patent documents cited in the above-mentioned European search report.
The members are as contained in the European Patent Office EDP file on
The European Patent Office is in no way liable for these particulars which are merely given for the purpose of information.

05-03-2020

Patent document cited in search report	Publication date	Patent family member(s)	Publication date
US 2002134529 A1	26-09-2002	BR 0200914 A	05-11-2002
		GB 2375817 A	27-11-2002
		JP 3675348 B2	27-07-2005
		JP 2002286396 A	03-10-2002
		US 2002134529 A1	26-09-2002

JP 2000249491 A	14-09-2000	NONE	

DE 4243495 A1	23-06-1994	NONE	

US 2017299283 A1	19-10-2017	BR 112017005949 A2	19-12-2017
		CN 107110619 A	29-08-2017
		EP 3198212 A1	02-08-2017
		FR 3026170 A1	25-03-2016
		JP 2017531149 A	19-10-2017
		KR 20170057420 A	24-05-2017
		US 2017299283 A1	19-10-2017
		WO 2016046290 A1	31-03-2016
