

(19)



(11)

EP 3 799 615 B1

(12)

EUROPEAN PATENT SPECIFICATION

(45) Date of publication and mention of the grant of the patent:

09.08.2023 Bulletin 2023/32

(51) International Patent Classification (IPC):

F25D 11/02 ^(2006.01) **F25B 40/02** ^(2006.01)
F25B 40/06 ^(2006.01)

(21) Application number: **19855898.3**

(52) Cooperative Patent Classification (CPC):

F25B 40/02; F25B 40/06; F25D 11/022;
F25B 2400/052; F25B 2400/054

(22) Date of filing: **16.08.2019**

(86) International application number:

PCT/KR2019/010437

(87) International publication number:

WO 2020/045868 (05.03.2020 Gazette 2020/10)

(54) **REFRIGERATOR**

KÜHLSCHRANK

RÉFRIGÉRATEUR

(84) Designated Contracting States:

AL AT BE BG CH CY CZ DE DK EE ES FI FR GB GR HR HU IE IS IT LI LT LU LV MC MK MT NL NO PL PT RO RS SE SI SK SM TR

(30) Priority: **31.08.2018 JP 2018162562**

24.05.2019 KR 20190061140

(43) Date of publication of application:

07.04.2021 Bulletin 2021/14

(73) Proprietor: **Samsung Electronics Co., Ltd.**

Suwon-si 16677 (KR)

(72) Inventors:

- **IWAMOTO, Tomoharu**
Yokohama-shi, Kanagawa 230--0027 (JP)
- **TAKASE, Hitoshi**
Yokohama-shi, Kanagawa 230--0027 (JP)
- **MATSUNO, Tomohiko**
Yokohama-shi, Kanagawa 230--0027 (JP)

• **SEO, Tatsuya**

Yokohama-shi, Kanagawa 230--0027 (JP)

• **SHIBUYA, Makoto**

Yokohama-shi, Kanagawa 230--0027 (JP)

• **AOKI, Ryota**

Yokohama-shi, Kanagawa 230--0027 (JP)

(74) Representative: **Rose, Kathryn Clare**

Venner Shipley LLP

200 Aldersgate

London EC1A 4HD (GB)

(56) References cited:

DE-T2- 60 113 072 **GB-A- 2 180 921**

JP-A- S61 228 276 **JP-A- 2001 280 802**

JP-A- 2001 280 802 **KR-A- 970 028 183**

KR-A- 19990 074 486 **KR-A- 20150 051 594**

US-A- 2 342 566 **US-A- 3 128 607**

US-A- 3 274 797 **US-A1- 2017 074 549**

Note: Within nine months of the publication of the mention of the grant of the European patent in the European Patent Bulletin, any person may give notice to the European Patent Office of opposition to that patent, in accordance with the Implementing Regulations. Notice of opposition shall not be deemed to have been filed until the opposition fee has been paid. (Art. 99(1) European Patent Convention).

EP 3 799 615 B1

Description**Technical Field**

[0001] The disclosure relates to a refrigerator.

Background Art

[0002] Patent JP4238731 B2 discloses a cooling cycle mechanism as a conventional refrigerator. The cooling cycle mechanism is operated in such a way that a capillary tube installed in the middle of a pipe for introducing a refrigerant, which is discharged from a condenser, into an evaporator, and a suction pipe for introducing a refrigerant, which is discharged from the evaporator, into a compressor, are connected in parallel with each other, and thus the refrigerant flowing in the capillary tube exchanges heat with the refrigerant flowing in the suction pipe, thereby improving the efficiency of the cooling cycle.

[0003] However, in the refrigerator disclosed in the patent JP4238731 B2, the direction of the refrigerant flowing in the capillary tube and the direction of the refrigerant flowing in the suction pipe are opposite to each other in a contact portion between the capillary tube and the suction pipe. Therefore, in practice, the heat exchange efficiency is only slightly improved, and the efficiency of the cooling cycle is not remarkably improved.

[0004] More particularly, the refrigerant flowing in the capillary tube has the highest temperature at the condenser side, and the temperature of the refrigerant is lowered as being away from the condenser. The refrigerant flowing in the suction pipe has the lowest temperature at the evaporator side, and the temperature of the refrigerant is increased as being away from the evaporator.

[0005] In the refrigerator disclosed in the patent JP4238731 B2, the heat exchange is performed between a refrigerant having a relatively high temperature on the condenser side of the capillary tube and a refrigerant separated from the evaporator of the suction pipe, and at the same time, the heat exchange is performed between a refrigerant separated from the condenser of the capillary tube and a refrigerant having a relatively high temperature on the evaporator side of the suction pipe, and thus the heat exchange efficiency is only slightly improved.

[0006] An air conditioner having a reversible system for either heating or cooling an enclosure is described in US2342566A. Heat exchangers having a capillary tube section are described in US3274797A and US2017/0074549A1.

Disclosure of Invention**Technical Problem**

[0007] Therefore, it is an aspect of the present disclo-

sure to provide a refrigerator including a cooling cycle mechanism having improved cooling cycle efficiency by more effectively performing heat exchange between a refrigerant discharged from an evaporator and a refrigerant discharged from a condenser. Additional aspects of the present disclosure will be set forth in part in the description which follows and, in part, will be obvious from the description, or may be learned by practice of the present disclosure.

Solution to Problem

[0008] In accordance with the present invention, there is provided a refrigerator according to claim 1. Optional features are set out in the dependent claims.

[0009] Because refrigerants flowing in both heat exchangers perform the parallel flow, heat exchange is performed between a relatively high temperature refrigerant in the condenser side of the first pipe and a relatively low temperature refrigerant in the evaporator side of the second pipe. Accordingly, the heat exchange efficiency may be greatly improved, and the efficiency of the cooling cycle may be improved.

[0010] The heat exchanger of the second pipe may be installed to extend from an end of the evaporator side to the compressor side.

[0011] Because heat exchange is performed between the refrigerant flowing in the first pipe and the lowest temperature refrigerant flowing in the second pipe, the heat exchange efficiency may be further improved and the efficiency of the cooling cycle may be improved.

[0012] The heat exchanger of the first pipe and the heat exchanger of the second pipe may be arranged as follows. That is, the heat exchanger of the first pipe and the heat exchanger of the second pipe may be arranged in parallel to each other in the vertical direction, and the heat exchanger of the first pipe and the heat exchanger of the second pipe may be arranged in parallel in the horizontal direction. The vertical direction is not limited to a perfectly vertical direction but includes a substantially vertical direction. The horizontal direction is not limited to a perfectly horizontal direction, and includes a substantially horizontal direction.

[0013] Because at least one section in which the first pipe intersects the second pipe is provided, the heat exchanger may be formed between the first pipe and the second pipe regardless of the arrangement of the devices constituting the cooling cycle mechanism. Accordingly, heat exchange may be performed between the upstream side in which the refrigerant flowing in the first pipe has a relatively high temperature, and the upstream side in which the refrigerant flowing in the second pipe has a relatively low temperature, thereby improving the heat exchange efficiency of the cooling cycle mechanism. The intersecting position may include a state in which the first pipe and the second pipe intersect with each other while the first pipe and the second pipe are in contact with each other.

[0014] The first pipe may include an expander configured to expand the refrigerant, which is discharged from the condenser. In this case, the expander may be a capillary tube constituting at least a part of the first pipe, and the heat exchanger of the first pipe may be constituted by the capillary tube. The expander may be an expansion valve installed in the middle of the first pipe.

[0015] The refrigerator may further include an insulating member configured to cover at least a part of both the heat exchangers.

[0016] Because both the heat exchangers are arranged inside the insulating member, heat exchange is more efficiently performed between the refrigerants flowing in both the heat exchangers. An outer wall of the refrigerator housing body may be used as the insulating member.

[0017] The insulating member may cover at least the upstream side of both the heat exchangers, and the insulating member may further cover a portion other than both the heat exchangers in the first pipe and the second pipe.

[0018] The heat exchanger may be arranged between a machine room in which at least one of the compressor and the condenser is placed and a cooling room in which the evaporator is placed. The heat exchanger of the first pipe may be arranged on the machine room side, and the heat exchanger of the second pipe may be arranged on the cooling room side.

[0019] The heat exchanger of the first pipe in which a high temperature refrigerant flows may be arranged on the machine room side in which a device that becomes hot is placed, and the heat exchanger of the second pipe in which a low temperature refrigerant flows may be arranged on the cooling room side in which a device that becomes cold is placed. Accordingly, the heat exchange rate in the heat exchanger may be improved.

[0020] Before undertaking the DETAILED DESCRIPTION below, it may be advantageous to set forth definitions of certain words and phrases used throughout this patent document: the terms "include" and "comprise," as well as derivatives thereof, mean inclusion without limitation; the term "or," is inclusive, meaning and/or; the phrases "associated with" and "associated therewith," as well as derivatives thereof, may mean to include, be included within, interconnect with, contain, be contained within, connect to or with, couple to or with, be communicable with, cooperate with, interleave, juxtapose, be proximate to, be bound to or with, have, have a property of, or the like; and the term "controller" means any device, system or part thereof that controls at least one operation, such a device may be implemented in hardware, firmware or software, or some combination of at least two of the same. It should be noted that the functionality associated with any particular controller may be centralized or distributed, whether locally or remotely.

[0021] Definitions for certain words and phrases are provided throughout this patent document, those of ordinary skill in the art should understand that in many, if

not most instances, such definitions apply to prior, as well as future uses of such defined words and phrases.

Advantageous Effects of Invention

[0022] As is apparent from the above description, by using the cooling cycle mechanism of the refrigerator, it may be possible to improve the efficiency of the cooling cycle by effectively exchanging heat between the refrigerant discharged from the evaporator and a refrigerant discharged from the condenser.

Brief Description of Drawings

[0023] For a more complete understanding of the present disclosure and its advantages, reference is now made to the following description taken in conjunction with the accompanying drawings, in which like reference numerals represent like parts:

FIG. 1 illustrates a perspective view of a refrigerator according to an embodiment of the disclosure;

FIG. 2 illustrates a cross-sectional view of a state in which a second housing body element (cooling unit) is connected to a first housing body element of the refrigerator according to an embodiment of the disclosure;

FIG. 3 illustrates a cross-sectional view of a state in which the second housing body element (cooling unit) is not connected to the first housing body element of the refrigerator according to an embodiment of the disclosure;

FIG. 4 illustrates a perspective view of the cooling unit according to an embodiment of the disclosure;

FIG. 5 illustrates a schematic diagram of a cooling cycle according to an embodiment of the disclosure; and

FIGS. 6A and 6B illustrate schematic diagrams of a heat exchanger of a first pipe and a second pipe according to an embodiment of the disclosure.

Mode for the Invention

[0024] FIGS. 1 through 6B, discussed below, and the various embodiments used to describe the principles of the present disclosure in this patent document are by way of illustration only and should not be construed in any way to limit the scope of the disclosure. Those skilled in the art will understand that the principles of the present disclosure may be implemented in any suitably arranged system or device.

[0025] The disclosure will be described more fully hereinafter with reference to the accompanying drawings.

[0026] A refrigerator 100 according to an embodiment is mainly used in general households. However, the disclosure is applicable not only to a domestic refrigerator but also to a commercial refrigerator. In addition, the refrigerator according to an embodiment includes not only

a refrigerator provided with a refrigerating compartment and a freezing compartment but also a refrigerator provided with only refrigerating compartment or a refrigerator provided with only freezing compartment.

<Embodiment>

[0027] As illustrated in FIGS. 1 and 2, the refrigerator 100 according to an embodiment includes a refrigerator housing body (BD) forming an inner space (IS) and a cooling cycle mechanism (CM) provided with each device configured to cool the inner space IS. Further, the cooling cycle mechanism CM according to an embodiment includes a compressor 20, a blowing fan 21, a condenser 22 and two evaporators 23, which are corresponding to each device.

[0028] The refrigerator housing body BD is formed in such a way that opposite side surfaces, a back surface (rear surface), a ceiling surface, and a bottom surface thereof is surrounded by an outer wall 10 and a front surface (forward surface) thereof is opened. A pair of doors (D) is installed in the refrigerator housing body BD through a hinge to close the opening. In addition, the refrigerator housing body BD is divided into two housing body elements (BD1 and BD2) along a predetermined separate surface (SS), as illustrated in FIG. 2. Particularly, the refrigerator housing body BD is divided into the two housing body elements BD1 and BD2 along a tilted separate surface SS extending from the back surface (rear surface) to the bottom surface.

[0029] Therefore, the two housing body elements BD1 and BD2 are all formed by an insulating member forming the outer wall 10 of the refrigerator housing body BD. More particularly, the two housing body elements BD1 and BD2 are formed by an insulating member that is formed by foaming an insulating material such as urethane resin in a casing material generally used as the outer wall 10 of the refrigerator housing body BD.

[0030] Between the two housing body elements BD1 and BD2, one side housing body element B1 (hereinafter referred to as "first housing body element BD1") occupies a main portion of the inner space IS and arranged in the front side about the separate surface SS, as illustrated in FIGS. 2 and 3. Further, in the first housing body element BD1, a partition 11 configured to divide the inner space IS into the front side and the separate surface SS side is installed inside the inner space IS. In the first housing body element BD1, a storage room (SR) configured to be opened and closed by one pair of doors D is placed in the front side of the partition 11, and a part of a re-cooling room (CR) configured to re-cool gas cooling the storage room SR is formed in the separate surface SS side of the partition 11. Although not shown, the first housing body element BD1 according to an embodiment is provided with a partition configured to divide the storage room SR and the re-cooling room CR into the left and the right to separate the storage room SR and the re-cooling room CR for refrigerating and freezing.

[0031] In the storage room SR, a plurality of shelves 12 are provided on the upper side, and a plurality of drawers (not shown) are provided on the lower side. The partition 11 is provided with an inlet 11a introducing gas from the storage room SR to the re-cooling room CR along the bottom surface, and an outlet 11b delivering the gas from the cooling room CR to the storage room SR along the back surface. The first housing body element BD1 is provided with a duct 30 extending from the outlet 11b provided in the partition 11 to the storage room SR. The duct 30 is provided with a wind inlet 30a installed in accordance with a height of each shelf 12 or the drawer, and a fan 31 is installed around the outlet 11b of the partition 11.

[0032] Between the two housing body elements BD1 and BD2, the other side housing body element B2 (hereinafter referred to as "second housing body element BD2"), is connected to the first housing body element BD1 to form the re-cooling room CR together with the first housing body element BD1. Further, the second housing body element BD2 forms a machine room (MR) at the outer space of the refrigerator and the machine room MR receives the compressor 20, the blowing fan 21 and the condenser 22. The second housing body element BD2 is provided with two evaporators 23 on the inner space forming the re-cooling room CR. The second housing body element BD2 and the cooling cycle mechanism CM are both installed on a support board (B) together with a control box (CB) to constitute the cooling unit. Thus, the second housing body element BD2 may be detachably connected to the first housing body element BD1 as the cooling unit.

[0033] When the first housing body element BD1 and the second housing body element BD2 are connected to each other, the storage room SR and the re-cooling room CR are formed in the inner space, and the machine room MR is formed in the outer space. Among the devices constituting the cooling cycle mechanism CM, the evaporator 23 is placed in the re-cooling room CR in the inner space, and the compressor 20, the blowing fan 21 and the condenser 22 are placed in the machine room MR in the outer space. In addition, according to an embodiment, when the first housing body element BD1 and the second housing body element BD2 are connected, the re-cooling room CR is partitioned into the left and right, and the evaporator 23 is respectively positioned in one re-cooling room CR for refrigerating and one re-cooling room CR for freezing. That is, one of the two evaporators 23 serves as a refrigerating evaporator 23a, and the other serves as a freezing evaporator 23b.

[0034] Further, as illustrated in FIG. 5, each device constituting the cooling cycle mechanism CM is connected by a plurality of pipe 5, and each device is configured to circulate the refrigerant in the pipe. Particularly, the devices arranged on the machine room MR side are connected the devices arranged on the re-cooling room CR side through a first pipe P1 introducing the refrigerant, which is discharged from the condenser 22, into the re-

frigerating evaporator 23a and a second pipe P2 introducing the refrigerant, which is discharged from the freezing evaporator 23b, into the compressor 20. Further, devices arranged on the machine room MR side are connected to each other through a third pipe P3 introducing the refrigerant, which is discharged from the compressor 20, to the condenser 22, and devices arranged on the re-cooling room CR side are connected to each other through a fourth pipe P4 introducing the refrigerant, which is discharged from the refrigerating evaporator 23a, to the freezing evaporator 23b. Accordingly, the compressor 20, the condenser 22, and the two evaporators 23a and 23b constituting the cooling cycle mechanism CM are connected to each other through each pipe and thus the refrigerant is circulated through each of these devices.

[0035] Further, the first pipe P1 is provided with an expander P1a configured to expand a refrigerant, which is flowing in the first pipe P1, before the refrigerant flows into the refrigerating evaporator 23a. According to an embodiment, the expander P1a corresponds to a capillary tube (indicated by a dotted line in FIG. 4) forming a part of the first pipe P1. The capillary tube according to an embodiment constitutes the downstream side of the first pipe P1.

[0036] In addition, the first pipe P1 and the second pipe P2 are arranged to have a section (S) which is a part intersecting on the downstream side. The first pipe P1 and the second pipe P2 are provided with heat exchangers 24a and 24b. The heat exchangers 24a and 24b are positioned on the upstream side than the intersecting section, and the heat exchanger 24a and the heat exchanger 24b are arranged in parallel so as to exchange heat between the refrigerant flowing in the first pipe P1 and the refrigerant flowing in the second pipe P2. The heat exchanger 24a of the first pipe P1 and the heat exchanger 24b of the second pipe P2 are connected to be in parallel with each other (refer to FIG. 6 A). The first pipe P1 and the second pipe P2 according to an embodiment form the heat exchangers 24a and 24b by connecting the middle of the capillary tube P1a constituting the first pipe P1 to an end portion of the evaporator 23b side of the second pipe P2.

[0037] In addition, both the heat exchangers 24a and 24b are arranged to allow the refrigerant flowing in the first pipe P1 and the refrigerant flowing in the second pipe P2 to perform the parallel flow. That is, the refrigerant flowing in the heat exchanger 24a of the first pipe P1 and the refrigerant flowing in the heat exchanger 24b of the second pipe P2 flow in the same direction.

[0038] Further, as illustrated in FIG. 4, at least a part of the heat exchangers 24a and 24b is placed in the insulating member constituting the second housing body element BD2. Particularly, the first pipe P1 extends from the machine room MR side to pass through the inside of the second housing body element BD2 and then reach the re-cooling room CR side. The second pipe P2 extends from the re-cooling room CR side to pass through the

inside of the second housing body element BD2 and then reach the machine room MR side. A section of the first pipe P1 and the second pipe 2 passing through the inside of the second housing body element BD2 corresponds to the heat exchangers 24a and 24b. Therefore, both the heat exchangers 24a and 24b are covered by the insulating member constituting the second housing body element BD2.

[0039] As illustrated in FIG. 4, both the heat exchangers 24a and 24b pass through a section (insulating member) that is separated between the machine room MR and the evaporator 23a in the re-cooling room CR in the second housing body element BD2. Both the heat exchangers 24a and 24b extend in a serpentine manner in the second housing body element BD2. Accordingly, it is possible to secure a distance in a longitudinal direction between the heat exchanger 24a of the first pipe P1 and the heat exchanger 24b of the second pipe P2 and thus it is possible to secure a sufficient distance for heat exchange. An upstream end of the first pipe P1 constituting the heat exchanger 24a extends toward the machine room MR and connected to the condenser 22 and a downstream end thereof extends toward the re-cooling room CR and connected to the refrigerating evaporator 23a. An upstream end of the second pipe P2 constituting the heat exchanger 24b extends toward the re-cooling room CR and connected to the freezing evaporator 23b, and a downstream end thereof extends toward the machine room MR and connected to the compressor 20.

[0040] Therefore, the first pipe P1 is configured to cool a high temperature and high pressure liquid refrigerant, which is discharged from the condenser 22, in some degree by using the heat exchanger 24a and configured to allow two-phase state of liquid refrigerant and gas refrigerant to flow to the refrigerating evaporator 23a. The second pipe P2 is configured to heat a low temperature and low pressure gas refrigerant, which is discharged from the freezing evaporator 23b, in some degree by using the heat exchanger 24b and configured to allow the refrigerant to flow to the compressor 20. Accordingly, it is possible to efficiently use heat generated by the first pipe P1 and the second pipe P2, thereby improving the efficiency of the cooling cycle.

[0041] In addition, as illustrated in FIG. 6A, the heat exchanger 24a of the first pipe P1 is arranged in the machine room MR side, and the heat exchanger 24b of the second pipe P2 is arranged in the re-cooling room CR side. In other words, the heat exchanger 24a of the first pipe P1 and the heat exchanger 24b of the second pipe P2 are arranged in the vertical direction with respect to each other. As illustrated in FIG. 6B, the heat exchanger 24a of the first pipe P1 and the heat exchanger 24b of the second pipe P2 may be arranged in the horizontal direction with respect to each other.

<Other Embodiments>

[0042] In the above embodiment, the capillary tube is

used as the expander P1a of the first pipe P1, but the disclosure is not limited thereto. Therefore, an expansion valve may be used as the expander P1a. In this case, the same heat exchange efficiency may be obtained although either or both of the upstream side and the downstream side of the expansion valve of the first pipe P1 serves as the heat exchanger 24a.

[0043] In the above embodiment, the heat exchangers 24a and 24b are formed in the middle between the first pipe P1 and the second pipe P2. However, the heat exchanger 24b of the second pipe P2 is formed in an end portion of the evaporator 23 side. In this the case, the coldest refrigerant, which is discharged from the evaporator 23 to the second pipe P2, may be used for heat exchange with the refrigerant flowing in the first pipe P1, thereby further improving the heat exchange efficiency.

[0044] However, when employing the above-mentioned configuration, it is required that the first pipe P1 extends from the machine room MR to pass through the second housing body element BD2 and bypasses the recooling room CR, and then passes through the inside of the second housing body element BD2 together with the second pipe P2.

[0045] In the above embodiment, the first pipe P1 and the second pipe P2 are arranged to have a section S which is a part intersecting on the downstream side. However, the section S on which the first pipe P1 and the second pipe P2 intersect is not limited to the downstream side, and thus the section S may be arranged on the upstream side or the center. That is, the intersecting section S may be arranged in the middle between the first pipe P1 and the second pipe P2 in accordance with the arrangement of the device constituting the cooling cycle mechanism CM (particularly, the arrangement of the compressor 20 and the condenser 22 in the outer space, and the arrangement of the evaporator 23 in the inner space).

[0046] In the above embodiment, the heat exchanger 24 is formed on one position in the middle between the first pipe P1 and the second pipe P2, but the heat exchanger 24 may be formed intermittently in a plurality of positions.

[0047] In the above embodiment, the configuration in which only the heat exchangers 24a and 24b of the first pipe P1 and the second pipe P2 pass through the inside of the second housing body element BD2, is employed but is not limited thereto. Therefore, a configuration in which other than the heat exchangers 24a and 24b of the first pipe P1 and the second pipe P2, other part may pass through the inside of the second housing body element BD2 may be employed.

[0048] In the above embodiment, the refrigerator is described as a type in which the cooling cycle mechanism CM is detachable from the cooling unit. However, the disclosure may be applicable to a refrigerator in which the cooling cycle mechanism CM is not detachable.

Claims

1. A refrigerator comprising:

5 a cooling cycle mechanism comprising a compressor (20), a condenser (22), and an evaporator (23) and configured to cool an inner space of the refrigerator;
 10 a first pipe (P1) comprising a first heat exchanger (24a) and configured to guide a refrigerant from the condenser (22) to the evaporator (23); and
 15 a second pipe (P2) comprising a second heat exchanger (24b) and configured to guide the refrigerant from the evaporator (23) to the compressor (20),
 20 wherein the second heat exchanger (24b) is arranged in contact with the first heat exchanger (24a) and configured to exchange heat with the first heat exchanger (24a),
 25 wherein the first heat exchanger (24a) and the second heat exchanger (24b) are arranged to guide the refrigerant in a same direction, and
 30 wherein the first heat exchanger (24a) is bent in a serpentine form, **characterized in that** the second heat exchanger (24b) is arranged parallel to the first heat exchanger (24a) and the second heat exchanger (24b) includes a bent shape in a serpentine form corresponding to the first heat exchanger (24a).

2. The refrigerator of claim 1, wherein the first heat exchanger (24a) is arranged at a portion of the first pipe (P1) that is closer to the condenser (22), and the second heat exchanger (24b) is arranged at a portion of the second pipe (P2) that is closer to the evaporator (23).

3. The refrigerator of claim 1, wherein at least a portion of the second pipe (P2) intersects with the first pipe (P1).

4. The refrigerator of claim 1, wherein the second pipe (P2) is arranged in a vertical direction with respect to the first pipe (P1) or in a horizontal direction with respect to the first pipe (P1).

5. The refrigerator of claim 1, further comprising:

50 a machine room, MR, including the compressor (20) and the condenser (22);
 a cooling room, CR, including the evaporator (23); and
 a housing body element, BD, configured to separate the machine room from the cooling room and comprising an insulating member,
 55 wherein at least a portion of the first heat exchanger (24a) and at least a portion of the sec-

- ond heat exchanger (24b) pass through the insulating member.
6. The refrigerator of claim 5, wherein the insulating member is configured to:
- surround a part of the first heat exchanger (24a) closer to the condenser (22), and surround a part of the second heat exchanger (24b) closer to the evaporator (23).
7. The refrigerator of claim 5, wherein the first heat exchanger (24a) is arranged closer to the machine room than the cooling room, and the second heat exchanger (24b) is arranged closer to the cooling room than the machine room.
8. The refrigerator of claim 1, wherein the first pipe (P1) comprises an expander (P1a) configured to expand the refrigerant.
9. The refrigerator of claim 8, wherein the expander (P1a) is arranged to form at least a portion of the first heat exchanger (24a).
10. The refrigerator of claim 9, wherein the expander (P1a) comprises a capillary tube or an expansion valve.
11. The refrigerator of claim 1, further comprising:
- a first housing body element (BD1) including a storage room, SR; and a second housing body element (BD2) including the cooling cycle mechanism, wherein the second housing body element (BD2) is detachably coupled to the first housing body element (BD1).
12. The refrigerator of claim 1, wherein the evaporator (23) comprises a refrigerating evaporator (23a) and a freezing evaporator (23b) connected to the refrigerating evaporator (23a),
- wherein the first pipe (P1) is configured to connect the condenser (22) and the refrigerating evaporator (23a), and wherein the second pipe (P2) is configured to connect the refrigerating evaporator (23a) to the compressor (20).
13. The refrigerator of claim 11, wherein when the second housing body element (BD2) is coupled to the first housing body element (BD1), the second housing body element (BD2) forms a cooling room, CR, with the first housing body element (BD1), and the second heat exchanger (24b) is arranged closer to the cooling room than the first heat exchanger

(24a).

14. The refrigerator of claim 1, wherein the first heat exchanger (24a) is positioned upstream with respect to a flow direction of the refrigerant through the first pipe (P1), and the second heat exchanger (24b) is positioned upstream with respect to a flow direction of the refrigerant through the second pipe (P2).

Patentansprüche

1. Kühlschrank, umfassend:

einen Kühlkreislaufmechanismus, umfassend einen Verdichter (20), einen Kondensator (22) und einen Verdampfer (23) und der zum Kühlen eines Innenraums des Kühlschranks konfiguriert ist;

eine erste Rohrleitung (P1), umfassend einen ersten Wärmetauscher (24a) und die konfiguriert ist, um ein Kältemittel von dem Kondensator (22) zu dem Verdampfer (23) zu leiten; und

eine zweite Rohrleitung (P2), umfassend einen zweiten Wärmetauscher (24b) und die konfiguriert ist, um das Kältemittel von dem Verdampfer (23) zu dem Verdichter (20) zu leiten,

wobei der zweite Wärmetauscher (24b) in Kontakt mit dem ersten Wärmetauscher (24a) angeordnet ist und konfiguriert ist, um mit dem ersten Wärmetauscher (24a) Wärme auszutauschen,

wobei der erste Wärmetauscher (24a) und der zweite Wärmetauscher (24b) angeordnet sind, um das Kältemittel in dieselbe Richtung zu leiten, und

wobei der erste Wärmetauscher (24a) serpentin förmig gebogen ist, **dadurch gekennzeichnet, dass** der zweite Wärmetauscher (24b) parallel zu dem ersten Wärmetauscher (24a) angeordnet ist und der zweite Wärmetauscher (24b) eine dem ersten Wärmetauscher (24a) entsprechende gebogene Form in Serpentin form beinhaltet.

2. Kühlschrank nach Anspruch 1, wobei der erste Wärmetauscher (24a) an einem Abschnitt der ersten Rohrleitung (P1) angeordnet ist, der dem Kondensator (22) näher ist, und der zweite Wärmetauscher (24b) an einem Abschnitt der zweiten Rohrleitung (P2) angeordnet ist, der dem Verdampfer (23) näher ist.
3. Kühlschrank nach Anspruch 1, wobei sich mindestens ein Abschnitt der zweiten Rohrleitung (P2) mit der ersten Rohrleitung (P1) kreuzt.

4. Kühlschrank nach Anspruch 1, wobei die zweite Rohrleitung (P2) in einer vertikalen Richtung in Bezug auf die erste Rohrleitung (P1) oder in einer horizontalen Richtung in Bezug auf die erste Rohrleitung (P1) angeordnet ist.

5. Kühlschrank nach Anspruch 1, ferner umfassend:

einen Maschinenraum, MR, der den Verdichter (20) und den Kondensator (22) beinhaltet; einen Kühlraum CR, der den Verdampfer (23) beinhaltet; und ein Gehäusekörperelement BD, das konfiguriert ist, um den Maschinenraum von dem Kühlraum zu trennen und umfassend ein Isolierelement, wobei mindestens ein Abschnitt des ersten Wärmetauschers (24a) und mindestens ein Abschnitt des zweiten Wärmetauschers (24b) durch das Isolierelement verläuft.

6. Kühlschrank nach Anspruch 5, wobei das Isolierelement konfiguriert ist, um:

einen Abschnitt des ersten Wärmetauschers (24a) näher an dem Kondensator (22) zu umgeben, und einen Abschnitt des zweiten Wärmetauschers (24b) näher an dem Verdampfer (23) zu umgeben.

7. Kühlschrank nach Anspruch 5, wobei der erste Wärmetauscher (24a) näher an dem Maschinenraum als an dem Kühlraum angeordnet ist, und der zweite Wärmetauscher (24b) näher an dem Kühlraum als an dem Maschinenraum angeordnet ist.

8. Kühlschrank nach Anspruch 1, wobei die erste Rohrleitung (P1) einen Expander (P1a) umfasst, der konfiguriert ist, um das Kältemittel zu expandieren.

9. Kühlschrank nach Anspruch 8, wobei der Expander (P1a) angeordnet ist, um mindestens einen Abschnitt des ersten Wärmetauschers (24a) zu bilden.

10. Kühlschrank nach Anspruch 9, wobei der Expander (P1a) ein Kapillarrohr oder ein Expansionsventil umfasst.

11. Kühlschrank nach Anspruch 1, ferner umfassend:

ein erstes Gehäusekörperelement (BD1), das einen Speicherraum, SR, beinhaltet; und ein zweites Gehäusekörperelement (BD2), das den Kühlkreislaufmechanismus beinhaltet, wobei das zweite Gehäusekörperelement (BD2) abnehmbar mit dem ersten Gehäusekör-

perelement (BD1) verbunden ist.

12. Kühlschrank nach Anspruch 1, wobei der Verdampfer (23) einen Kühlverdampfer (23a) und einen Gefrierverdampfer (23b) umfasst, der mit dem Kühlverdampfer (23a) verbunden ist,

wobei die erste Rohrleitung (P1) konfiguriert ist, um den Kondensator (22) und den Kühlverdampfer (23a) zu verbinden, und wobei die zweite Rohrleitung (P2) konfiguriert ist, um den Kühlverdampfer (23a) mit dem Verdichter (20) zu verbinden.

13. Kühlschrank nach Anspruch 11, wobei, wenn das zweite Gehäusekörperelement (BD2) mit dem ersten Gehäusekörperelement (BD1) gekoppelt ist, das zweite Gehäusekörperelement (BD2) einen Kühlraum, CR, mit dem ersten Gehäusekörperelement (BD1) bildet, und

der zweite Wärmetauscher (24b) näher an dem Kühlraum angeordnet ist als der erste Wärmetauscher (24a).

14. Kühlschrank nach Anspruch 1, wobei der erste Wärmetauscher (24a) stromaufwärts in Bezug auf eine Strömungsrichtung des Kältemittels durch die erste Rohrleitung (P1) angeordnet ist, und der zweite Wärmetauscher (24b) stromaufwärts in Bezug auf eine Strömungsrichtung des Kältemittels durch die zweite Rohrleitung (P2) angeordnet ist.

Revendications

1. Réfrigérateur comprenant :

un mécanisme de cycle de refroidissement comprenant un compresseur (20), un condenseur (22) et un évaporateur (23) et configuré pour refroidir un espace intérieur du réfrigérateur ; une première conduite (P1) comprenant un premier échangeur de chaleur (24a) et configurée pour guider un fluide frigorigène du condenseur (22) à l'évaporateur (23) ; et une seconde conduite (P2) comprenant un second échangeur de chaleur (24b) et configurée pour guider le fluide frigorigène de l'évaporateur (23) au compresseur (20), dans lequel le second échangeur de chaleur (24b) est agencé en contact avec le premier échangeur de chaleur (24a) et configuré pour échanger de la chaleur avec le premier échangeur de chaleur (24a), dans lequel le premier échangeur de chaleur (24a) et le second échangeur de chaleur (24b) sont agencés pour guider le fluide frigorigène dans une même direction, et

- dans lequel le premier échangeur de chaleur (24a) est courbé en forme de serpent, **caractérisé en ce que** le second échangeur de chaleur (24b) est agencé parallèlement au premier échangeur de chaleur (24a) et le second échangeur de chaleur (24b) comprend une forme courbée en forme de serpent correspondant au premier échangeur de chaleur (24a).
2. Réfrigérateur selon la revendication 1, dans lequel le premier échangeur de chaleur (24a) est agencé au niveau d'une partie de la première conduite (P1) qui est plus proche du condenseur (22), et le second échangeur de chaleur (24b) est agencé au niveau d'une partie de la seconde conduite (P2) qui est plus proche de l'évaporateur (23).
3. Réfrigérateur selon la revendication 1, dans lequel au moins une partie de la seconde conduite (P2) coupe la première conduite (P1).
4. Réfrigérateur selon la revendication 1, dans lequel la seconde conduite (P2) est agencée dans une direction verticale par rapport à la première conduite (P1) ou dans une direction horizontale par rapport à la première conduite (P1).
5. Réfrigérateur selon la revendication 1, comprenant en outre :
- un compartiment des machines, MR, comprenant le compresseur (20) et le condenseur (22) ; une chambre de refroidissement, CR, comprenant l'évaporateur (23) ; et un élément de corps de carter, BD, configuré pour séparer le compartiment des machines du compartiment de refroidissement et comprenant un élément isolant, dans lequel au moins une partie du premier échangeur de chaleur (24a) et au moins une partie du second échangeur de chaleur (24b) traversent l'élément isolant.
6. Réfrigérateur selon la revendication 5, dans lequel l'élément isolant est configuré pour :
- entourer une partie du premier échangeur de chaleur (24a) plus près du condenseur (22), et entourer une partie du second échangeur de chaleur (24b) plus proche de l'évaporateur (23).
7. Réfrigérateur selon la revendication 5, dans lequel le premier échangeur de chaleur (24a) est agencé plus près du compartiment des machines que du compartiment de refroidissement, et le second échangeur de chaleur (24b) est agencé plus près du compartiment de refroidissement que du compartiment des machines.
8. Réfrigérateur selon la revendication 1, dans lequel la première conduite (P1) comprend un détendeur (P1a) configuré pour détendre le fluide frigorigène.
9. Réfrigérateur selon la revendication 8, dans lequel le détendeur (P1a) est agencé pour former au moins une partie du premier échangeur de chaleur (24a).
10. Réfrigérateur selon la revendication 9, dans lequel le détendeur (P1a) comprend un tube capillaire ou une soupape de détente.
11. Réfrigérateur selon la revendication 1, comprenant en outre :
- un premier élément de corps de carter (BD1) comprenant un compartiment de stockage, SR ; et un second élément de corps de carter (BD2) comprenant le mécanisme de cycle de refroidissement, dans lequel le second élément de corps de carter (BD2) est couplé de manière amovible au premier élément de corps de carter (BD1).
12. Réfrigérateur selon la revendication 1, dans lequel l'évaporateur (23) comprend un évaporateur de réfrigération (23a) et un évaporateur de congélation (23b) connecté à l'évaporateur de réfrigération (23a),
- dans lequel la première conduite (P1) est configurée pour connecter le condenseur (22) et l'évaporateur de réfrigération (23a), et dans lequel la seconde conduite (P2) est configurée pour connecter l'évaporateur de réfrigération (23a) au compresseur (20).
13. Réfrigérateur selon la revendication 11, dans lequel lorsque le second élément de corps de carter (BD2) est couplé au premier élément de corps de carter (BD1), le second élément de corps de carter (BD2) forme une chambre de refroidissement, CR, avec le premier élément de corps de carter (BD1), et le second échangeur de chaleur (24b) est agencé plus près de la chambre de refroidissement que le premier échangeur de chaleur (24a).
14. Réfrigérateur selon la revendication 1, dans lequel le premier échangeur de chaleur (24a) est positionné en amont par rapport à une direction d'écoulement du fluide frigorigène à travers la première conduite (P1), et le second échangeur de chaleur (24b) est positionné en amont par rapport à un sens d'écoulement du fluide frigorigène à travers la seconde conduite (P2).

[Fig. 1]

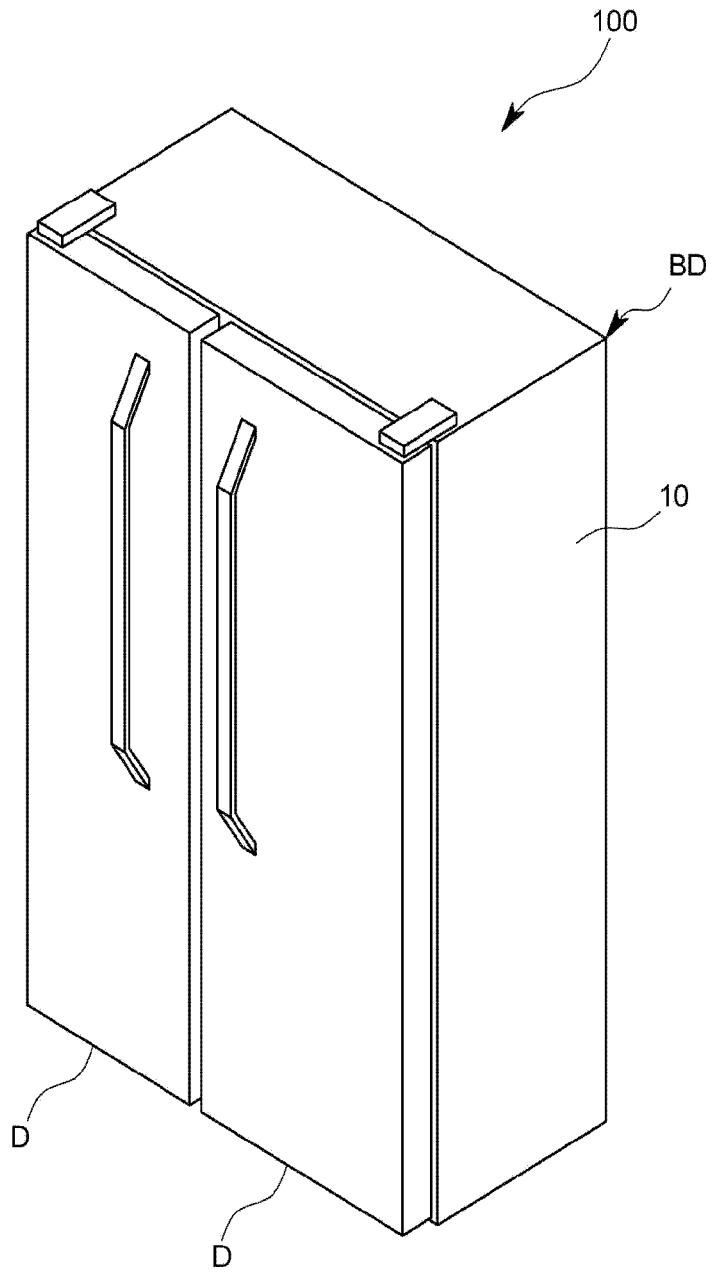

[Fig. 2]

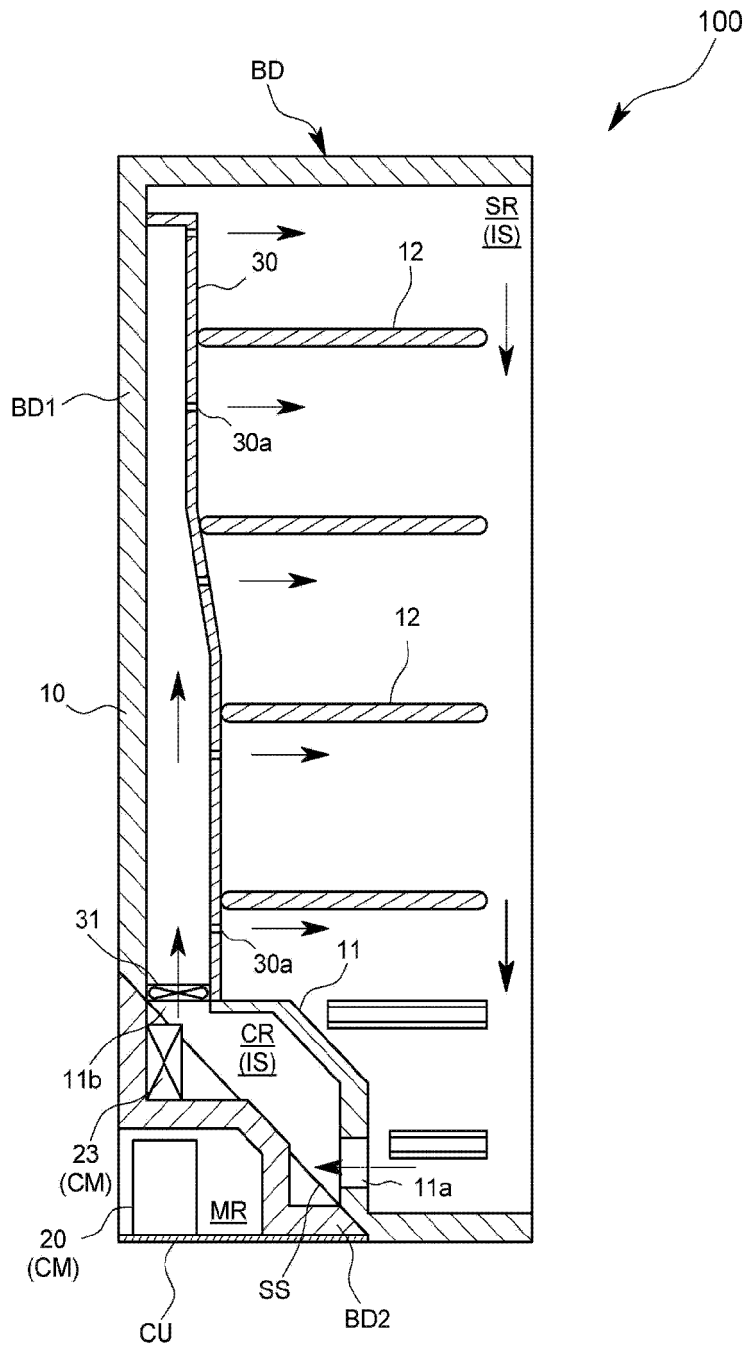

[Fig. 3]

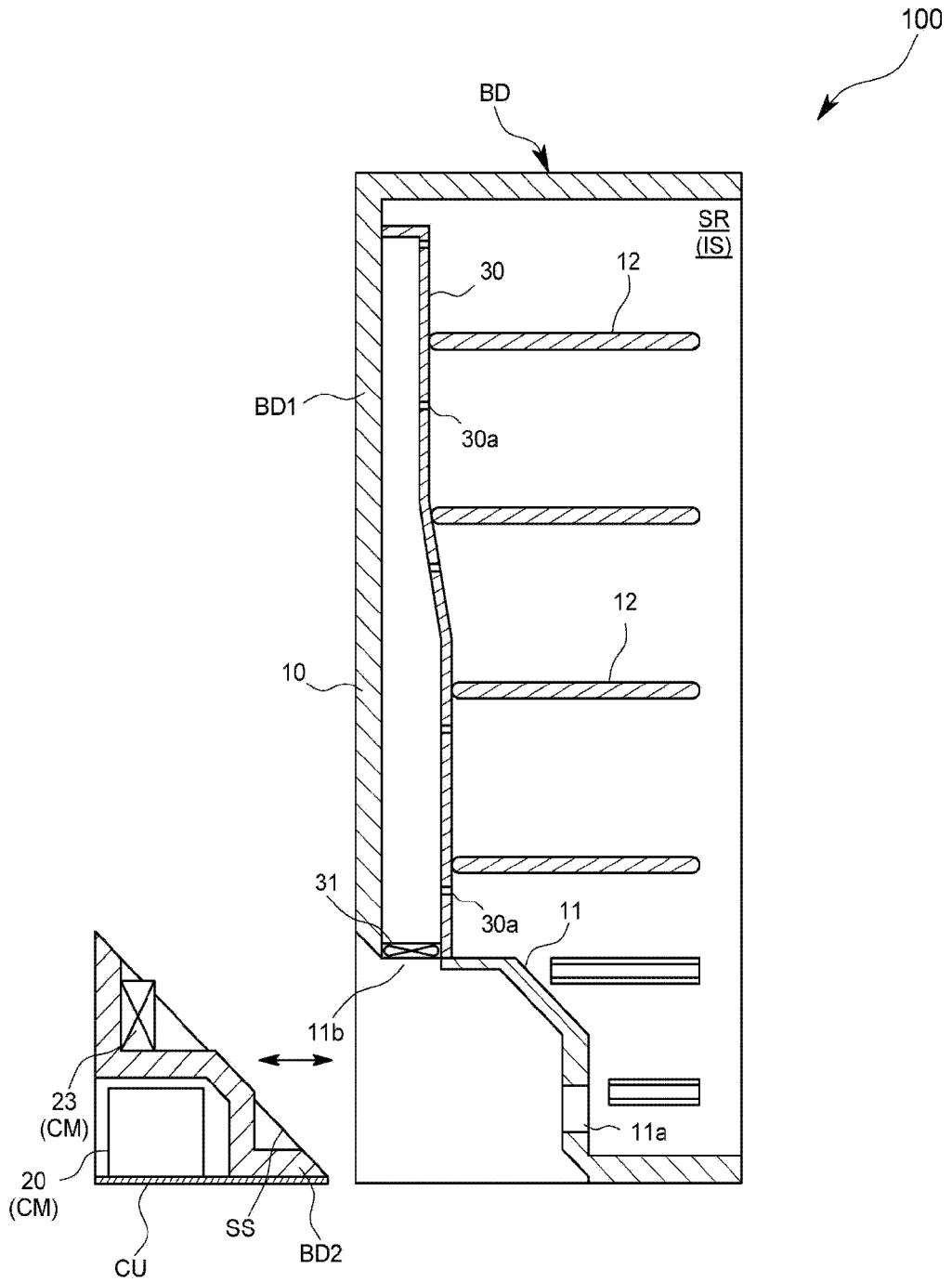

[Fig. 4]

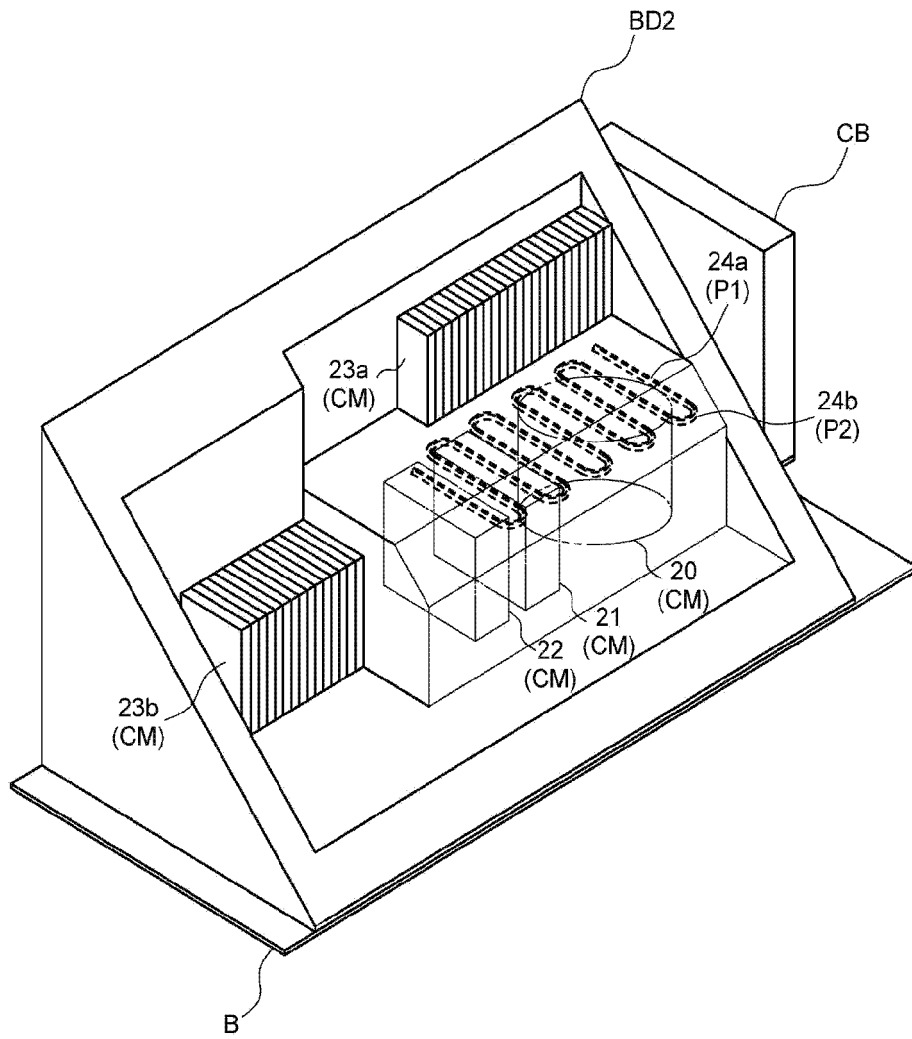

[Fig. 5]

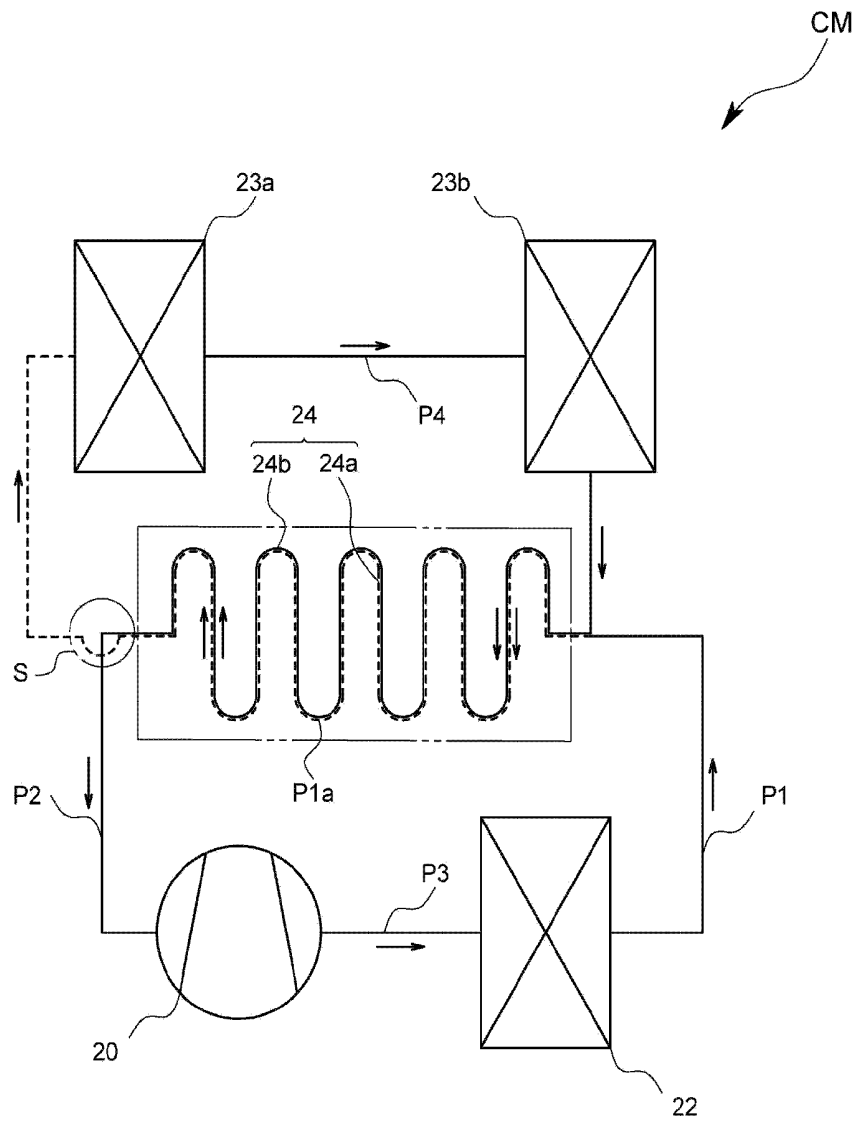

[Fig. 6a]

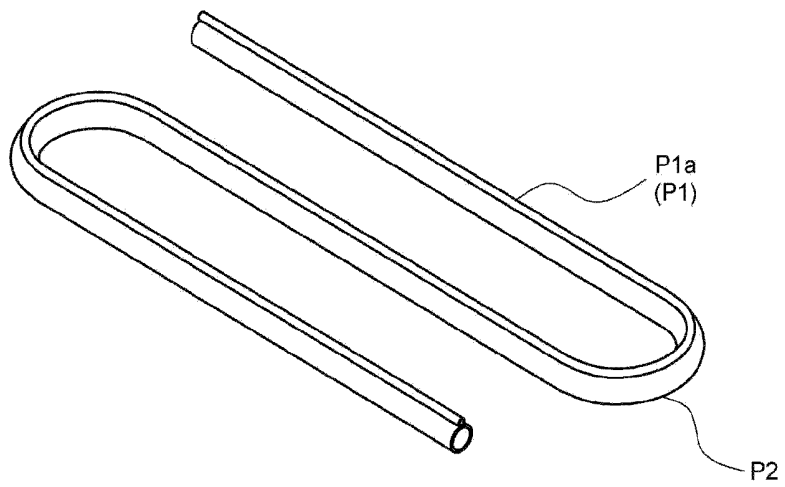

[Fig. 6b]

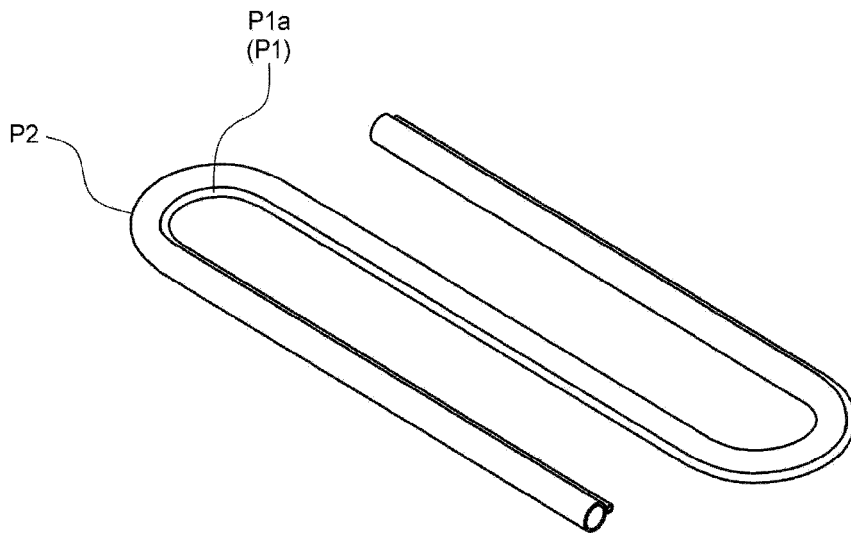

REFERENCES CITED IN THE DESCRIPTION

This list of references cited by the applicant is for the reader's convenience only. It does not form part of the European patent document. Even though great care has been taken in compiling the references, errors or omissions cannot be excluded and the EPO disclaims all liability in this regard.

Patent documents cited in the description

- JP 4238731 B [0002] [0003] [0005]
- US 2342566 A [0006]
- US 3274797 A [0006]
- US 20170074549 A1 [0006]