

(19)



(11)

EP 3 819 440 A1

(12)

EUROPEAN PATENT APPLICATION

(43) Date of publication:
12.05.2021 Bulletin 2021/19

(51) Int Cl.:
E04D 3/363^(2006.01) E04D 3/361^(2006.01)

(21) Application number: **19425080.9**

(22) Date of filing: **11.11.2019**

(84) Designated Contracting States:
AL AT BE BG CH CY CZ DE DK EE ES FI FR GB GR HR HU IE IS IT LI LT LU LV MC MK MT NL NO PL PT RO RS SE SI SK SM TR
 Designated Extension States:
BA ME
 Designated Validation States:
KH MA MD TN

(71) Applicant: **Sandrini Metalli S.p.A.**
24062 Costa Volpino (Bergamo) (IT)

(72) Inventor: **DAMIOLI, Alberto**
24062 Costa Volpino (Bergamo) (IT)

(74) Representative: **Tansini, Elio Fabrizio Bugnion S.p.A.**
Viale Lancetti 17
20158 Milano (IT)

(54) **STRUCTURE FOR SURFACE COVERING**

(57) Structure (1) for the covering of surfaces, comprising mainly a first panel (2) and a second panel (3), each having a main portion (8) and, on opposite sides of the main portion (8), a first hooking portion (6), and a second hooking portion (7), at least partially shaped at the first hooking portion (6).

In a configuration of use, the second hooking portion (7) of the second panel (3) is applied on the first hooking

portion (6) of the first panel (2) according to a unique and predetermined positioning.

The structure (1) also comprises a fixing bracket (4) configured to interpose, in the configuration of use, between the first panel (2) and the second panel (3).

Finally, the structure (1) comprises an anchoring bracket (5) shaped so as to define a mounting portion (20) on which the fixing bracket (4) is applicable, in use.

Fig.1A

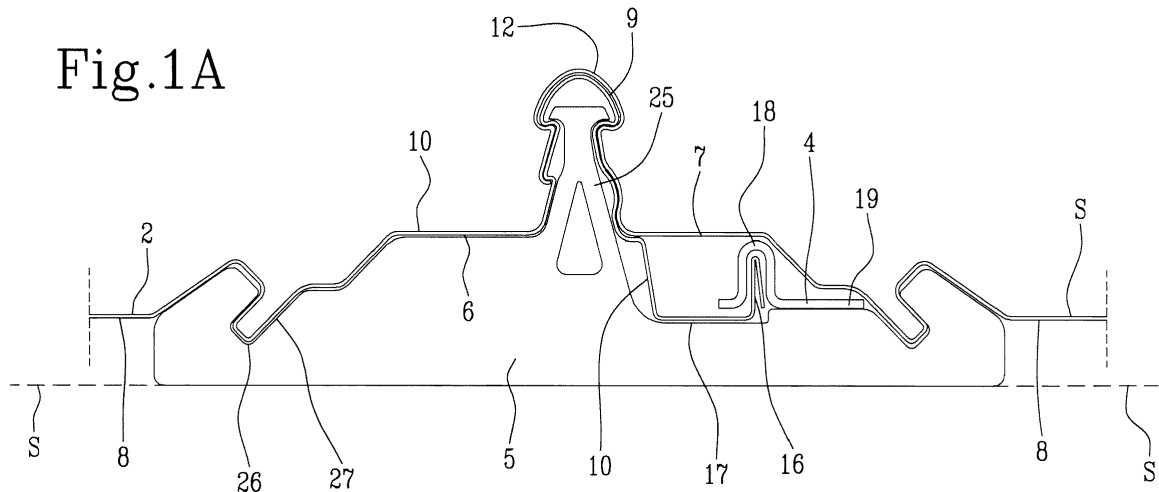

EP 3 819 440 A1

Description

[0001] The present invention relates to a structure for the covering of surfaces. In particular, the structure finds useful but not exclusive application in the building sector for roof and wall cladding.

[0002] Especially in the building sector, it is extremely important to be able to ensure covering structures for cladding surfaces that meet criteria such as mechanical stability, waterproofing, ease of installation and aesthetics.

[0003] Among the various structures of this type, it is known to use plate-like elements or panels, especially in metallic material, arranged adjacent to each other and anchored to a bearing structure.

[0004] Typically, these panels have two complementary hooking portions, arranged on opposite sides and extending parallel to each other for the entire extension of the panel.

[0005] Each hooking portion is configured in such a way that it can be coupled stably with the hooking portion of an adjacent panel.

[0006] In particular, the combination between two hooking portions essentially provides that one of the two hooking portions is such as to be housed at least partially inside the other one.

[0007] Typically, a fixing bracket is used for anchoring the panels to the bearing structure, which fixing bracket is configured to retain an end edge of the internal hooking portion.

[0008] However, this solution has several disadvantages.

[0009] In fact, if the covering structure were to be subjected to considerable external forces, the anchoring could be insufficiently robust to retain the panelling.

[0010] In particular, this anchoring system could be insufficiently robust if the forces had direction components with a tendency to lift the panels. Moreover, the coupling of the hooking portions is not sufficiently hermetic to prevent the passage of fluids, such as water.

[0011] In fact, these types of panels have recesses on the lower hooking portion, extending along the entire length of the panel, configured to collect and channel the filtered water between the two hooking portions.

[0012] However, this methodology can lead to water stagnation between the panels which causes deterioration in the structure over time.

[0013] In this context, the technical task underlying the present invention is to propose a cover and a kit for the covering of surfaces that overcome at least some of the aforementioned drawbacks of the known art.

[0014] In particular, it is an object of the present invention to provide a structure for the covering of surfaces capable of ensuring better anchoring to the bearing structure.

[0015] A further object of the present invention is to provide a structure for the covering of surfaces capable of ensuring a better mechanical response to external

stresses.

[0016] A further object of the present invention is to provide a structure for the covering of surfaces capable of ensuring a better hermetic quality of the panelling in order to avoid stagnation.

[0017] The specified technical task and the specified aims are substantially achieved by a covering for the covering of surfaces comprising a first and a second panel, a fixing bracket and an anchoring bracket.

[0018] The first and second panels have each a main portion, a first and a second hooking portion, arranged on opposite sides of the main portion and configured to engage the panels in a stable manner.

[0019] The fixing bracket and the anchoring bracket are configured to create a stable anchoring between panels and bearing structure and to improve the stability of the panelling.

[0020] Further characteristics and advantages of the present invention will become more apparent from the approximate and thus non-limiting description of a preferred but not exclusive embodiment of a cover and a kit for the covering of surfaces.

[0021] Such description will be made herein below with reference to the accompanying drawings, provided for indicative purposes only and therefore not limiting, wherein:

- Figures 1A and 1B show respective embodiments of a structure for the covering of surfaces according to the present invention;
- Figures 2A, 2B and 2C show different views of an embodiment of an anchoring bracket according to the present invention;
- Figures 3A, 3B and 3C show different views of a further embodiment of an anchoring bracket according to the present invention;
- Figures 4A and 4B show views of respective embodiments of panels according to the present invention;
- Figures 5A and 5B show views of respective embodiments of fixing brackets according to the present invention;
- Figure 6 shows an assembly sequence of the structure for the covering of surfaces according to the present invention.

[0022] A structure for the covering of surfaces has been indicated with reference number 1 as a whole. By way of example and without limitation, the term "surfaces" can refer to walls and roofs of buildings or structures typically arranged outside and therefore subject to atmospheric agents.

[0023] The structure 1 is shown in the figures in a section plane perpendicular to the longitudinal extension thereof.

[0024] In particular, the structure 1 extends in a longitudinal direction parallel to a longitudinal plane "S".

[0025] Substantially, this structure 1 comprises a first 2 and a second panel 3, a fixing bracket 4 and an an-

choring bracket 5.

[0026] First and second panels 2 and 3 are preferably but not necessarily the same. In other words, the first and second panels 2 and 3 preferably have the same profile and the same longitudinal extension.

[0027] In particular, each panel 2 and 3 has a first hooking portion 6, a second hooking portion 7 and a main portion 8 interposed between these first and second hooking portions 6 and 7.

[0028] As shown in the appended figures, the main portion 8 is defined by a planar profile lying on the longitudinal plane S. The main portion 8 is the panel portion 2 or 3 preferably having the largest planar extension.

[0029] On opposite sides, the main portion 8 is associated with the first and second hooking portions 6 and 7, which extend parallel to each other along a direction perpendicular to the section plane.

[0030] First and second hooking portions 6 and 7 are substantially configured to engage and match adjacent panels in a stable manner according to a unique and predetermined positioning.

[0031] In particular, the solution provides for the second hooking portion 7 of the second panel 3 to be complementary shaped with respect to the first hooking portion 6 of the first panel 2 so that, in a configuration of use, the second hooking portion 7 of the second panel 3 is applied on the first hooking portion 6 of the first panel 2 according to a unique and predetermined positioning, in particular by means of a shape coupling, so that the second panel 3 clads the first panel 2.

[0032] Furthermore, the first and second portions 6 and 7 define the panel portions suitable for being constrained to a bearing structure by means of a fixing bracket 4 and anchoring bracket 5.

[0033] Structurally, the first hooking portion 6 projects from the main portion 8, i.e. it extends away from the longitudinal plane "S" on which the main portion 8 lies.

[0034] Furthermore, the first hooking portion 6 has a complex and at least partially shaped profile.

[0035] In particular, the first hooking portion 6 has a head part 9 and a base part 10, which connects the head part 9 to the main portion 8.

[0036] The base part 10 has two walls 10a and 10b each having a substantially ascending profile approaching the head part 9.

[0037] The first wall 10a, according to an embodiment, provide for the presence of two interleaved ramps and two horizontal sections.

[0038] The second wall 10b provides for a single ramp.

[0039] The head part 9, associated with two ends of the base part 10, has an at least partially curved profile and extends transversely with respect to the longitudinal plane "S".

[0040] The head part 9 is configured in such a way as to be overall closed at the top and open at the bottom with a concavity turned downwards.

[0041] In particular, the head part 9 is shaped in such a way as to define two facing and opposite walls, extend-

ing away from the longitudinal plane "S". A plurality of first undercuts 11 is formed on these walls, which undercuts having concavity turned inwardly of the head part and at least partially upwards.

[0042] A preferred embodiment provides for the first hooking portion to have four first undercuts 11.

[0043] In particular, the first undercuts 11 are arranged in pairs, each on a respective wall of the head part so that the respective concavities of the first undercuts 11 are facing each other. In other words, these first undercuts 11 are substantially arranged in pairs on different walls of the head part 9 and formed at the same level with respect to the longitudinal plane "S".

[0044] Furthermore, according to a preferred embodiment, one of the first four undercuts 11 has an arched profile having a concavity turned inwardly of the head part.

[0045] This arched profile has a substantially curved shape and preferably an arc of a circle.

[0046] The second hooking portion 7 extends away from the main portion 8, in a transverse direction with respect to the longitudinal plane "S" and has a profile at least partially complimentary shaped with respect to the profile of the first hooking portion 6.

[0047] In particular, the second hooking portion 7 is configured in such a way as to be couplable, and in particular is configured to accommodate, at least partially, the first hooking portion 6 of an adjacent panel according to a unique and predetermined positioning.

[0048] In other words, the second hooking portion 7 has a profile following the profile of the first hooking portion 6 so that in configuration of use the first hooking portion 6 of the first panel 2 is stably housed according to a shape interlocking inside the second hooking portion 7 of the second panel 3.

[0049] Specifically, the second hooking portion 7 has a head portion 12 and a base part 13 at least partially following the head part 9 and the base part 10 of the first hooking portion 6.

[0050] The base portion 13 of the second hooking portion 7 has a substantially ascending profile approaching the head portion 12.

[0051] In particular, the base part 13 of the second hooking portion 7 follows the profile of the first wall of the base part 10 of the first hooking portion 6 so that, in configuration of use, the first and second hooking portion 6 and 7 are visually symmetrical.

[0052] Specifically, the base part 13 of the second hooking portion 7 will have two ramps interleaved with two horizontal sections.

[0053] One end of the base part 13 is associated with the head part 12, where the head part 12 has an at least partially curved profile and extends transversely with respect to the longitudinal plane "S".

[0054] In particular the head portion 12 of the second hooking portion 7 is shaped so as to define two facing and opposite walls, extending away from the longitudinal plane. Moreover, the head part 12 is configured in such

a way as to be overall closed at the top and open at the bottom with a concavity facing downwards.

[0055] The walls of the head part 12 of the second hooking portion 7 have a plurality of second undercuts 14 that are complementary in shape and in number such as to be able to be couplable with the first undercuts 11 of the first hooking portion 6.

[0056] In other words, in configuration of use, first and second undercuts 11 and 14 are permanently connected to each other, in particular by shape coupling.

[0057] A preferred embodiment provides that the second hooking portion 7 has four second undercuts 14 configured in such a way as to hook, in configuration of use, the respective first four undercuts 11 of the first hooking portion 6.

[0058] Advantageously, the presence of first and second undercuts 11 and 14 allows to stably constrain the first and second panels 2 and 3, avoiding relative movements if external forces act on the panels.

[0059] Furthermore, the concavity turned at least partially upwards allows a shape engagement such as to prevent or in particular undo the relative movements in a transverse direction to the longitudinal plane "S". Furthermore, the second hooking portion 7 of the second panel 3 is obtained by bending an end portion of the second panel 3 and one of the two walls of the second hooking portion 7 of the second panel 3 defines an end edge 15 of the panel.

[0060] According to a preferred embodiment, the end edge 15 of the second hooking portion 7 defines one of the second undercuts 14.

[0061] Advantageously, water infiltrations are considerably limited thanks to the second undercut 14 defined by the end edge 15 of the second hooking portion 7. Moreover, the end edge 15 of the second hooking portion 7, in configuration of use, adheres to the first hooking portion 6 giving the impression to an observer that there are no discontinuities between first and second panel 2 and 3.

[0062] Furthermore, according to a preferred embodiment, one of the four second undercuts 14 has an arched profile having a concavity turned inwardly of the head part and arranged in such a way that, in configuration of use, this second undercut 14 mates with the first undercut 11 having an arched profile of the first hooking portion 6.

[0063] Advantageously, thus structured, the head part 12 of the second hooking portion 7 of the second panel 3 allows a temporary housing for the head part 9 of the first hooking portion 6 of the first panel 2.

[0064] This temporary housing hinders or prevents the relative displacements between the first and second hooking portion 6 and 7 of the respective first and second panels 2 and 3 along a transverse direction parallel to the longitudinal plane "S".

[0065] The temporary housing, defined by the head portion 12 of the second hooking portion 7, thus allows the first hooking portion 6 of the first panel 2 to be correctly aligned with the second hooking portion 7 of the second

panel 3.

[0066] In this way, the application of a force that pushes the second hooking portion 7 towards the first hooking portion 6 causes the head portion 12 of the second hooking portion 7 to be urged to expand elastically to allow the insertion of the first hooking portion 6 of the first panel 2.

[0067] The anchoring of the panels 2 and 3 to the bearing structure takes place by means of an anchoring bracket 5 and a fixing bracket 4.

[0068] In this context, as will be described more fully in the following discussion, the combined action of the two brackets 4, 5 gives greater stability to the whole structure 1.

[0069] In other words, the presence of the anchoring bracket 5 which has a double anchoring given both independently and by the fixing bracket 4, leads to a greater stability when the two panels 2 and 3 hook with consequent advantages in terms of practical use and stabilization of the panels. This combined action of the brackets 4, 5 is able to withstand very high stresses caused for example by violent atmospheric agents.

[0070] In particular, the first panel 2 has an end relief 16 arranged adjacent to the first hooking portion 6.

[0071] Specifically, this end relief 16 is associated with an end portion 17 which is interposed between the first hooking portion 6 and this end relief 16.

[0072] This end relief 16 is configured so as to be inserted in a portion of the fixing bracket 4.

[0073] The fixing bracket 4 is made of metallic material, preferably of stainless steel, in particular by bending a single metallic plate.

[0074] The fixing bracket 4, in fact, has a hooking portion 18 defining a concave seat which is suitable to at least partially accommodate the end relief 16. In configuration of use, this hooking portion 18 is interposed between the first panel 2 and the second panel 3.

[0075] The fixing bracket 4 also has a connecting portion 19, preferably planar, and integral with the hooking portion 18, which can be stably connected to the anchoring bracket 5.

[0076] In other words, the connecting portion 19 of the fixing bracket 4, in configuration of use, is applicable to a mounting portion 20 shaped on the anchoring bracket 5 where this mounting portion 20 is arranged in a decentralized lateral position, in detail in proximity to or at a side edge of the anchoring bracket 5.

[0077] The structure 1 comprises first and second connecting means (not shown in the appended figures).

[0078] The first connecting means are configured for the stable fixing of the anchoring bracket 5 to the bearing structure while the second connecting means are configured for the stable fixing of the fixing bracket 4 to the mounting portion 20 of the anchoring bracket 5.

[0079] Furthermore, part of the first connecting means can coincide with at least part of the second connecting means.

[0080] First and second connecting means can for ex-

ample be threaded bodies. First and second connecting means are housed inside respective through holes 21a and holes 21b formed in the fixing bracket 4 and in the anchoring bracket 5 respectively.

[0081] In particular, the connecting portion 19 of the fixing bracket 4 has through holes 21a configured to accommodate the second connecting means, arranged in such a position as to mate, in configuration of use, with respective holes 21b formed on the mounting portion 20 of the anchoring bracket 5.

[0082] These holes 21b formed in the anchoring bracket 5 can be blind or through holes.

[0083] Furthermore, at these through holes 21a, the connecting portion 19 of the fixing bracket 4 has annular-shaped protrusions 22 engaging with corresponding flarings 23 of the holes 21b of the mounting portion 20. Advantageously, these protrusions 22 allow an automatic and facilitated centring during laying.

[0084] The anchoring bracket 5 has further holes 21b arranged to accommodate first connecting means for a stable anchoring to the bearing structure. Structurally, the anchoring bracket 5 is made of a monolithic body. Furthermore, the anchoring bracket 5 is made at least partially, preferably entirely, of polyamide or acetyl resin.

[0085] At a functional level, the anchoring bracket 5 substantially has the mounting portion 20 on which the fixing bracket 4 is housed and a receiving portion 24 on which portions of the first and second panels 2 and 3 are housed and supported.

[0086] In particular, the receiving portion is configured to receive and support the end portion 17 of the first panel 2, which is lying on the longitudinal plane "S".

[0087] In configuration of use, the hooking portion 18 of the fixing bracket 4 and the receiving portion 24 of the anchoring bracket 5 are such as to define a retaining seat adapted to retain the end relief 16 and the end portion 17 according to a unique and predetermined positioning.

[0088] This retaining seat is obtained by raising the mounting portion 20 or by hollowing out the receiving portion 24.

[0089] Furthermore, in configuration of use, the hooking portion 18 of the fixing bracket 4 is interposed on the first 2 and on the second panel 3. Subsequently, different embodiments of the structure 1 for the cladding of surfaces are treated.

[0090] A first embodiment, shown in Figure 1B, provides for an anchoring bracket 5 having a substantially plate-like configuration and in which said receiving surface 24 extends through a prevalent surface extension of the anchoring bracket so that, in use, the receiving portion 24 receive and support, both the end portion 17 of the first panel 2 interposed between the first hooking portion 6 and the end relief 16, and a central portion of the first panel 2 arranged between the first and second hooking portion 6 and 7 of the first panel 2.

[0091] A further embodiment, shown in Figure 1A, provides that the anchoring bracket 5 has a support element 25, preferably central, extending away from a lower sur-

face of the anchoring bracket 5.

[0092] In other words, this support element 25 extends transversely away from the longitudinal plane "S".

[0093] Moreover, this support element 25 is adapted to define, in configuration of use, a shape engagement with at least one of the first and second engaging portions 6 and 7.

[0094] In particular, the support element 25 has a tapered shape away from the lower surface of the anchoring bracket 5 and has a head 25a defining a section widening so as to engage with at least one undercut 11 or 14 of the first or second engaging portion 6 or 7.

[0095] Advantageously, thanks to the constraint between the support element 25 and the panels 2 and 3, the structure 1 has a higher mechanical resistance to external stresses.

[0096] In fact, even in the case in which the structure 1 is subjected to forces the components thereof tend to move the panels 2 and 3 away from the bearing structure, the anchoring bracket 5, by means of the support element 25, is able to retain the panels 2 and 3 firmly.

[0097] According to this embodiment, the anchoring bracket 5 has, preferably at or in proximity to its opposite sides, a pair of slots 26 configured to receive protrusions 27 present on the panels 2 and 3.

[0098] In fact, each panel 2 and 3 has a first and a second lower protrusion 27, each preferably defining a shaped groove, arranged respectively in proximity to the first and second hooking portions 6 and 7.

[0099] In particular, this first and second lower protrusion 27 are oriented in mutually non-parallel directions. These lower protrusions 27 are shaped so as to be housed by shape coupling in the pair of slots 26 formed in the anchoring bracket 5.

[0100] Advantageously, the shape coupling between lower protrusions 27 and pair of slots 26 improves the mechanical stability of the structure 1 and the stability of the anchoring.

[0101] A further embodiment, not shown in the appended figures, provides for anchoring brackets 5 having the slots 26 but not the support element 25. A further embodiment, not shown in the appended figures, provides for anchoring brackets 5 having a single slot 26.

[0102] A further embodiment, not shown in the appended figures, provides for anchoring brackets 5 having the support element 25 but not the slots 26. Advantageously, the present invention achieves the intended aim by overcoming the drawbacks complained about in the prior art and providing a structure for the covering of surfaces capable of ensuring a better anchoring to the bearing structure.

[0103] In fact, the presence of the anchoring bracket makes it possible to maintain the panelling in a correct arrangement, in particular the first and second panels, should stresses due to, for example, atmospheric agents occur.

[0104] In fact, the combined work of anchoring bracket and fixing bracket allows a robust anchoring of the pan-

elling to the bearing structure.

[0105] In particular, the joint action of the brackets provides a greater number of anchoring points and therefore a better distribution of the strains.

[0106] The shape anchoring between the anchoring bracket and the hooking portions ensures that the strain is not concentrated on the fixing bracket and consequently on the connecting means which secure it to the bearing structure.

[0107] Another object achieved is to provide a structure for the covering of surfaces capable of ensuring a better mechanical response to external stresses, avoiding premature breakage of the panelling and undesired displacements thereof.

[0108] In fact, the presence of the anchoring bracket makes it possible to maintain the panelling in a correct arrangement, in particular the first and second panels, should stresses due to, for example, atmospheric agents occur.

[0109] In particular, the shape anchoring between the hooking portions and the anchoring bracket allows to effectively stabilize the panels.

[0110] Furthermore, thanks to the support element and the slots present in the anchoring bracket, the structure is able to provide a more robust anchoring.

[0111] A further object achieved is to provide a structure for the covering of surfaces capable of ensuring a better hermetic quality of the panelling.

[0112] In fact, thanks to the mutually shaped conformation of the hooking portions and above all thanks to the presence of undercuts, the hooking portions are cohesively matched ensuring a hermetic seal which prevents the water from filtering.

Claims

1. A structure (1) for the covering of surfaces, comprising:

- a fixing bracket (4) having a connecting portion (19), preferably planar, stably anchored to a bearing structure, and a hooking portion (18) integral with the connecting portion (19) and defining a concave seat;

- a first panel (2) and a second panel (3), each having a main portion (8) and, on opposite sides of said main portion (8), a first hooking portion (6) at least partially shaped, projecting from said main portion (8), and a second hooking portion (7) at least partially shaped, projecting from said main portion (8), wherein said first panel (2) also has an end relief (16) arranged adjacent to said first hooking portion (6); preferably the second hooking portion (7) of the second panel (3) being complementary shaped with respect to the first hooking portion (6) of the first panel (2); in a configuration of use, the second hooking portion (7)

of the second panel (3) being applied on the first hooking portion (6) of the first panel (2) according to a unique and predetermined positioning, in particular by means of a shape coupling, in such a way that the second panel (3) clads the first panel (2) at said hooking portions (6, 7) coupled together;

wherein the hooking portion (18) of the fixing bracket (4) is configured to interpose, in said configuration of use, between the first panel (2) and the second panel (3) and to house said end relief (16) inside said concave seat;

characterized in that it further comprises an anchoring bracket (5) which can be fixed to the bearing structure and shaped so as to define a mounting portion (20) on which said connecting portion (19) of the fixing bracket (4) is applicable in use.

2. The structure (1) according to claim 1, comprising first connecting means for the stable fixing of the anchoring bracket (5) to the bearing structure and second connecting means for the stable fixing of the fixing bracket (4) to the mounting portion (20) of the anchoring bracket (5), wherein said anchoring bracket (5) has a receiving surface (24) configured to receive and support an end portion (17) of the first panel (2) interposed between the first hooking portion (6) and said end relief (16).

3. The structure (1) according to claim 2, wherein at least part of the first connecting means coincide with at least part of the second connecting means.

4. The structure (1) according to claim 2 or 3, wherein said connecting portion (19) of the fixing bracket (4) has a plate-like configuration and wherein said mounting portion (20) has a flat upper surface intended to receive and support said connecting portion (19) of the fixing bracket (4), said flat upper surface of the mounting portion (20) being raised with respect to said receiving surface (24).

5. The structure (1) according to one or more of the preceding claims 2 to 4, wherein said connecting portion (19) of the fixing bracket (4) has one or more through holes (21a) intended for housing said second connecting means and wherein said mounting portion (20) has corresponding holes (21b) for housing said second connecting means; said connecting portion (19) of the fixing bracket (4) having, at said through holes (21a), annular-shaped protrusions (22) engaging within corresponding flarings (23) of the holes (21b) of the mounting portion (20).

6. The structure (1) according to one or more of the preceding claims 2 to 5, wherein said mounting portion (20) is arranged on the anchoring bracket (5) in

a decentralized lateral position, in particular in proximity to or at a side edge of the anchoring bracket (5).

- 7. The structure (1) according to one or more of the preceding claims 2 to 6, wherein said anchoring bracket (5) has a substantially plate-like configuration and wherein said receiving surface (24) extends over a prevalent surface extension of the anchoring bracket (5) in such a way that, in use, said receiving surface (24) receives and supports, both an end portion (16) of the first panel (2) interposed between the first hooking portion (6) and said end relief (17), and a main portion (8) of the first panel (2) arranged between the first and second hooking portion (6, 7) of the first panel (2). 5
- 8. The structure (1) according to one or more of the preceding claims 2 to 6, wherein said anchoring bracket (5) has a support element (25), preferably central, extending away from a lower surface of the anchoring bracket (5) and able to define, in use, a shape engagement with at least one of said first and second anchoring portion (6, 7) coupled together. 10
- 9. The structure (1) according to claim 8, wherein said support element (25) has a tapered shape away from the lower surface of the anchoring bracket (5) and has a head (25a) defining a section widening to engage with at least one undercut (11, 14) of said first and/or second anchoring portion (6, 7) coupled together. 15
- 10. The structure (1) according to one or more of the preceding claims, wherein each panel (2, 3) has a first and a second lower protrusion (27), each preferably defining a shaped groove, arranged respectively in proximity to the first and the second hooking portion (6, 7), the lower protrusions (27) of the same panel (2, 3) being oriented in mutually non-parallel directions; and wherein said anchoring bracket (5) has, preferably at or in proximity to its opposite sides, a pair of slots (26) configured to each receive a corresponding one of said lower protrusions (27) of the panels (2, 3) and substantially complementary shaped with respect to the respective lower protrusion (27). 20
25
30
35
40
45
- 11. The structure (1) according to one or more of the preceding claims, wherein the first hooking portion (6) is shaped so as to define two facing and opposite walls extending away from the main portion (8) and having a plurality of first undercuts (11), and wherein the second hooking portion (7) is shaped so as to define two facing and opposite walls extending away from the main portion (8) and having a plurality of second undercuts (14), complementary to said first undercuts (11) so that respective first and second undercuts (11, 14) are stably connected to each oth- 50
55

er, in particular by shape coupling; preferably the second hooking portion (7) of the second panel (3) being entirely complementary shaped with respect to the first hooking portion (6) of the first panel (2).

- 12. The structure (1) according to claim 11, wherein the second hooking portion (7) of the second panel (3) is obtained by bending an end portion of the second panel (3) and wherein one of the two walls of said second hooking portion (7) of the second panel defines an end edge (15) of the panel (3); said end edge (15) defining an undercut (14) of the second hooking portion (7). 5
- 13. The structure (1) according to one or more of the preceding claims, wherein the anchoring bracket (5) is made of a monolithic body. 10
- 14. The structure (1) according to one or more of the preceding claims, wherein the anchoring bracket (5) is made at least partially, preferably entirely, of polyamide or acetyl resin. 15
- 15. The structure (1) according to one or more of the preceding claims, wherein the fixing bracket (4) is made of metallic material, preferably of stainless steel, in particular by bending a single metal plate. 20
25
30
35
40
45
50
55

Fig.1A

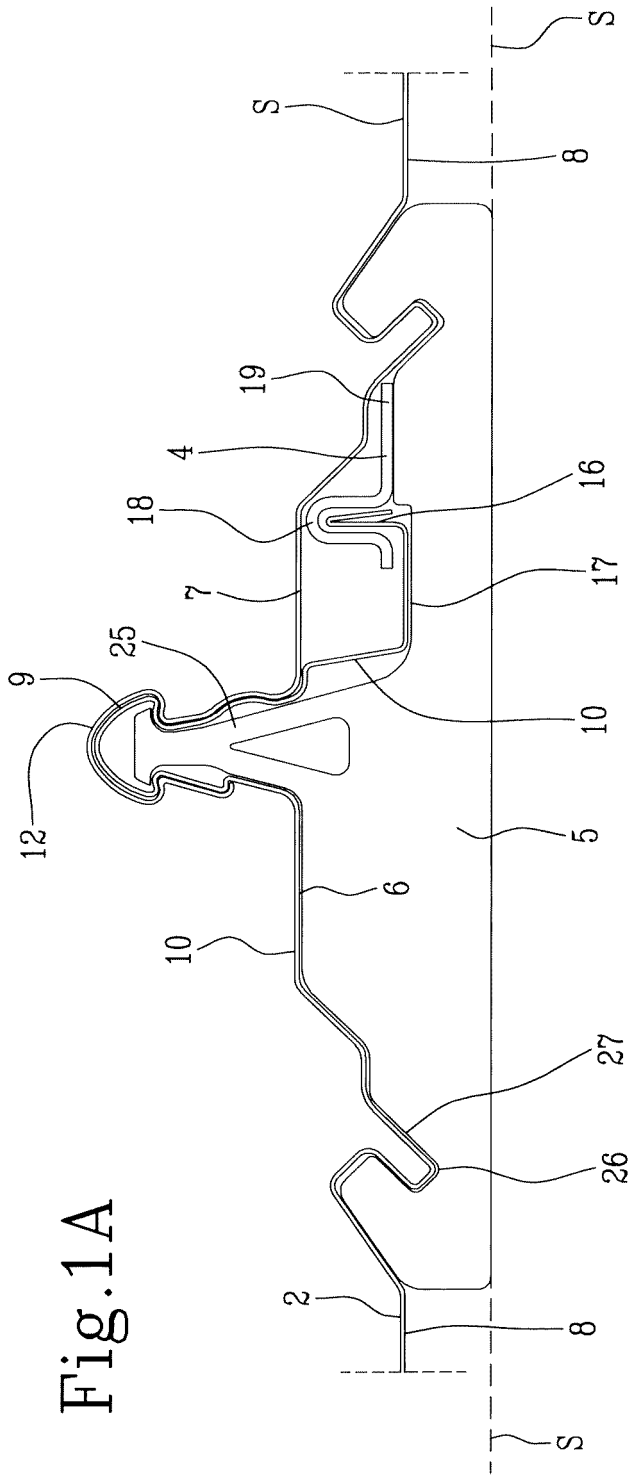

Fig.1B

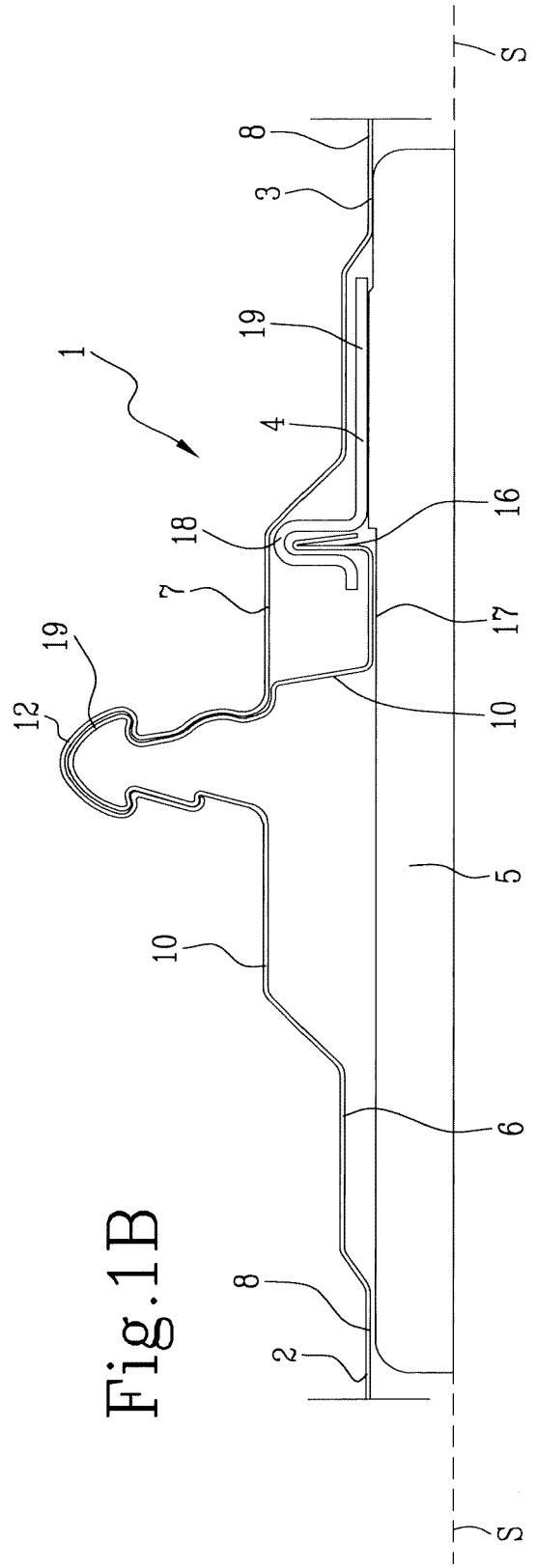

Fig.2A

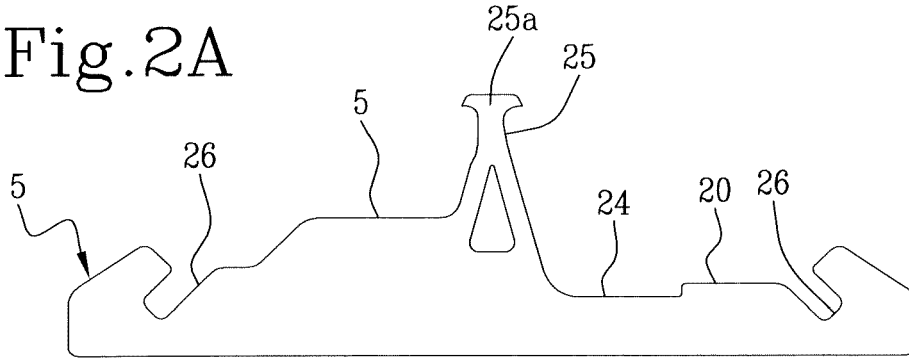

Fig.2B

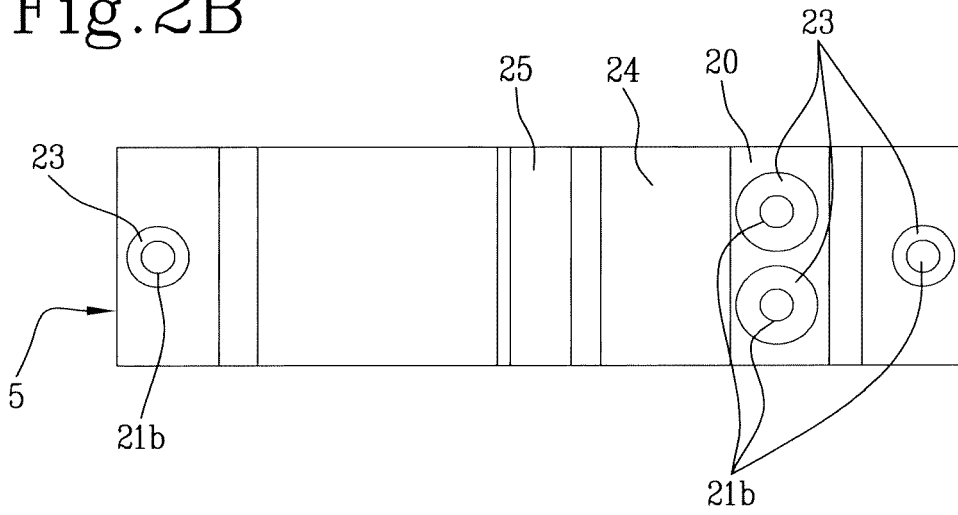

Fig.2C

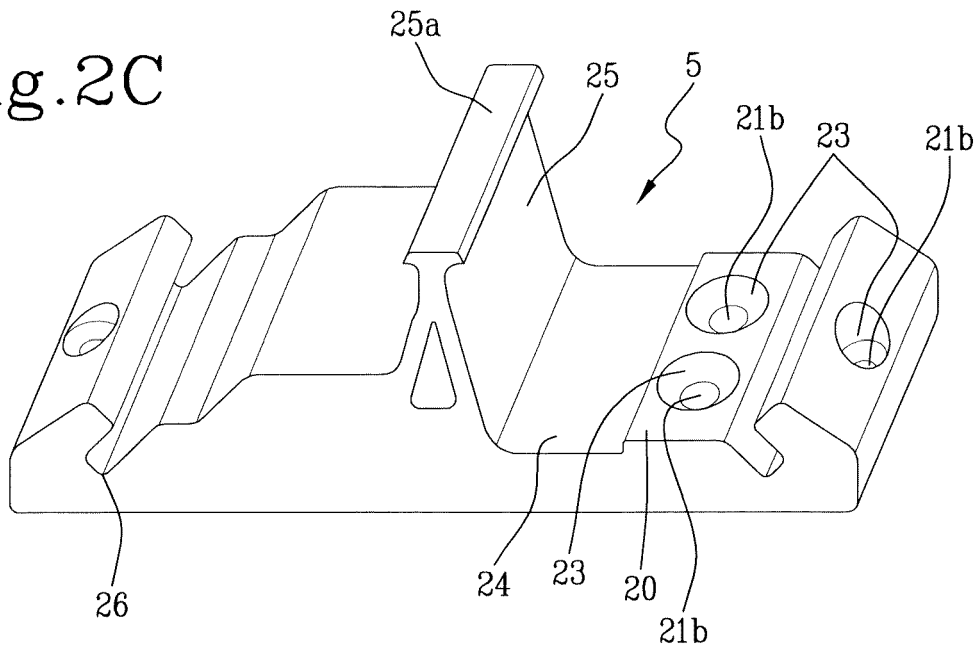

Fig.3A

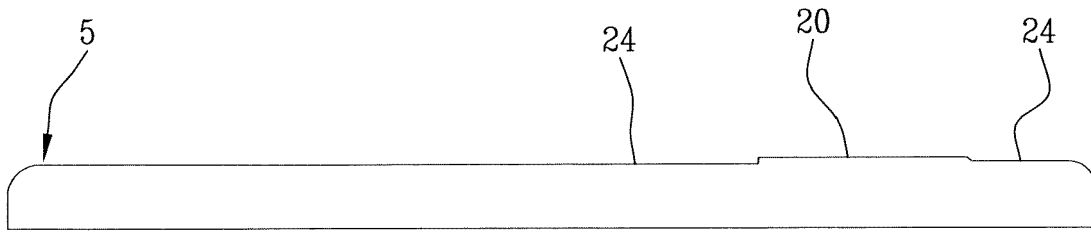

Fig.3B

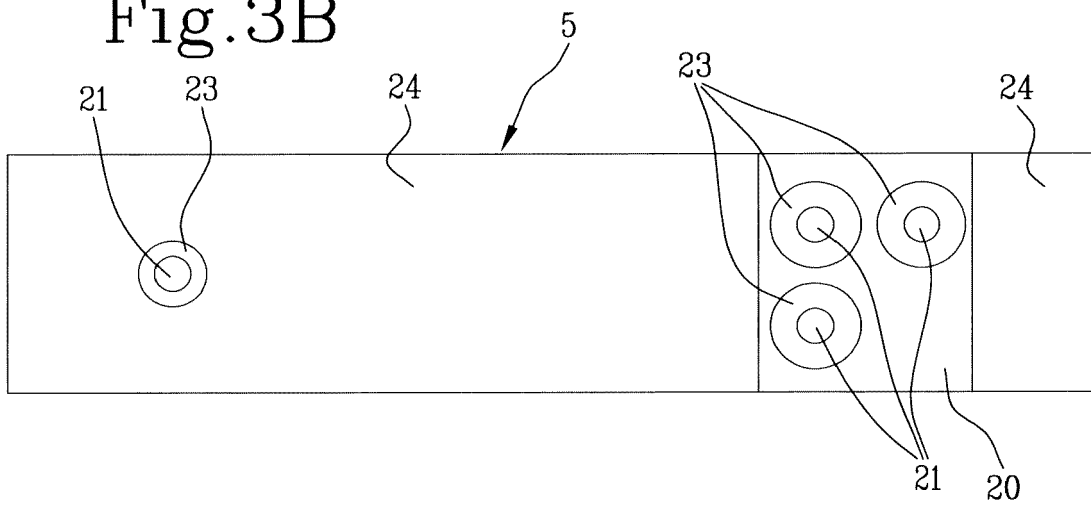
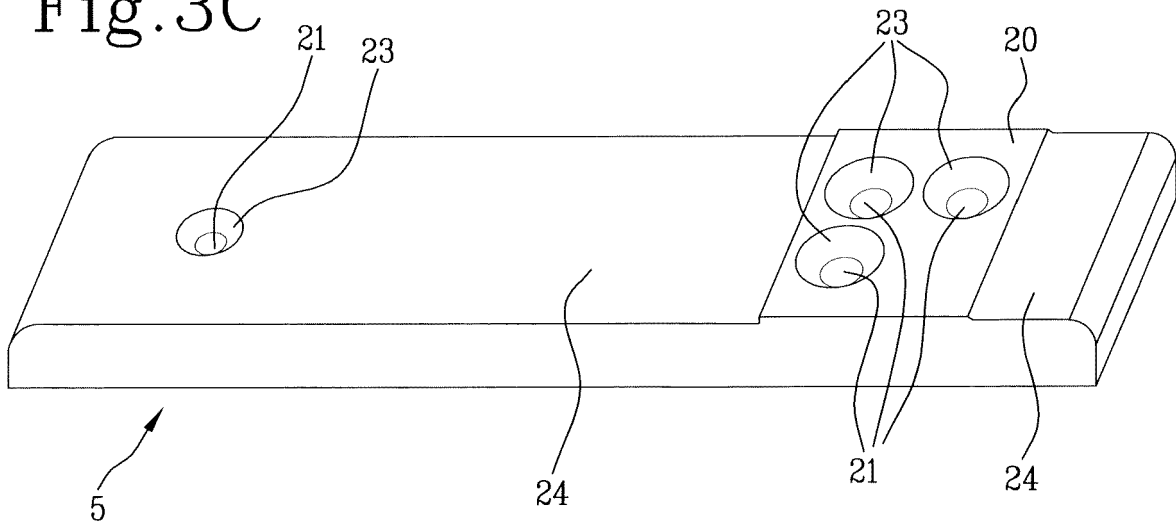

Fig.3C



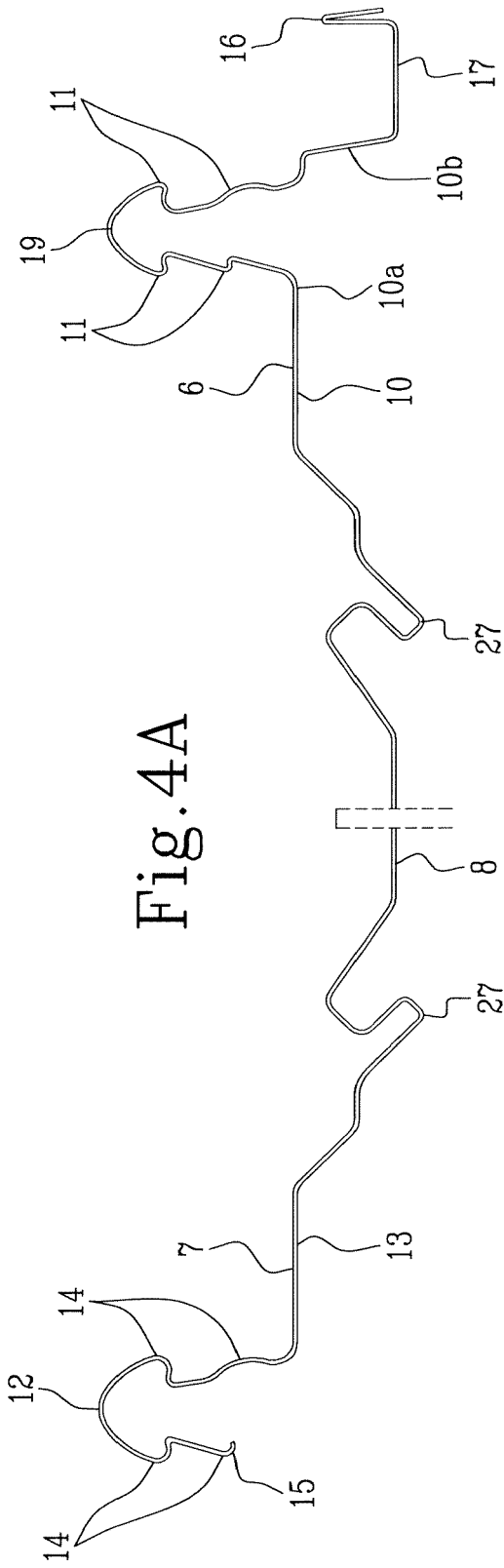

Fig. 4A

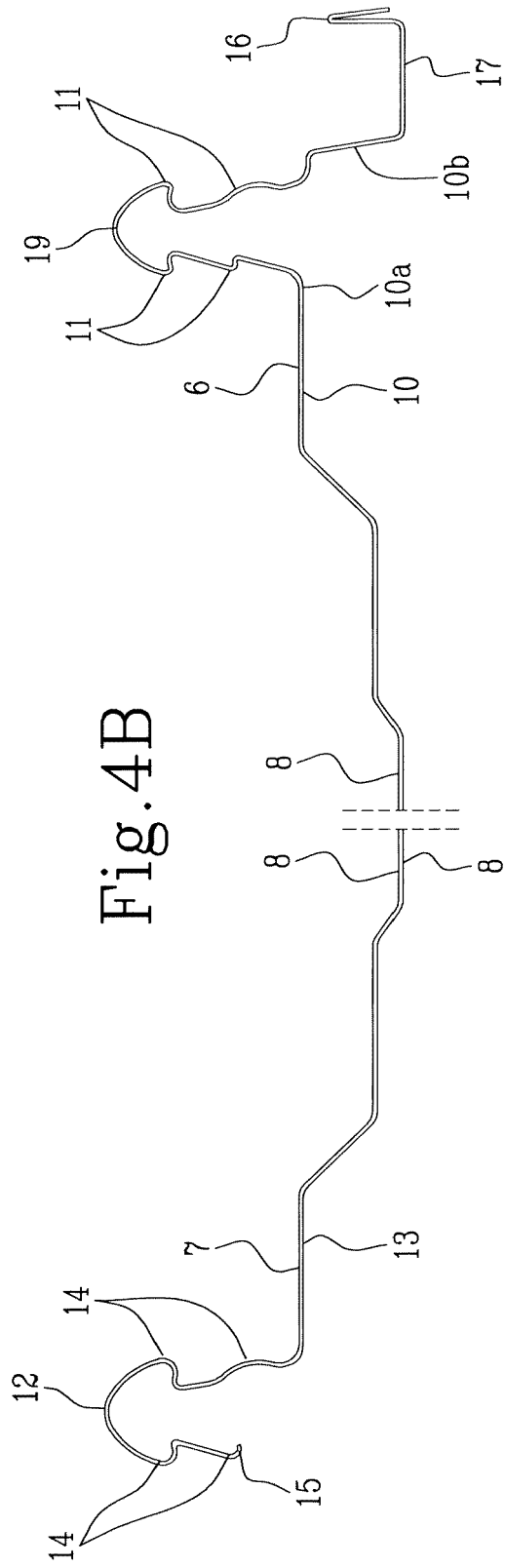

Fig. 4B

Fig.5A

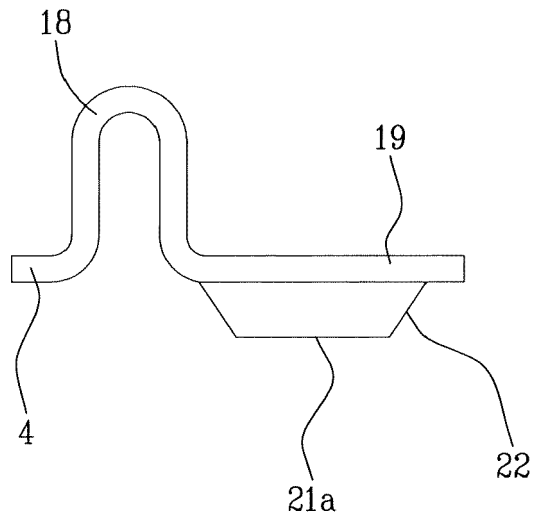

Fig.5B

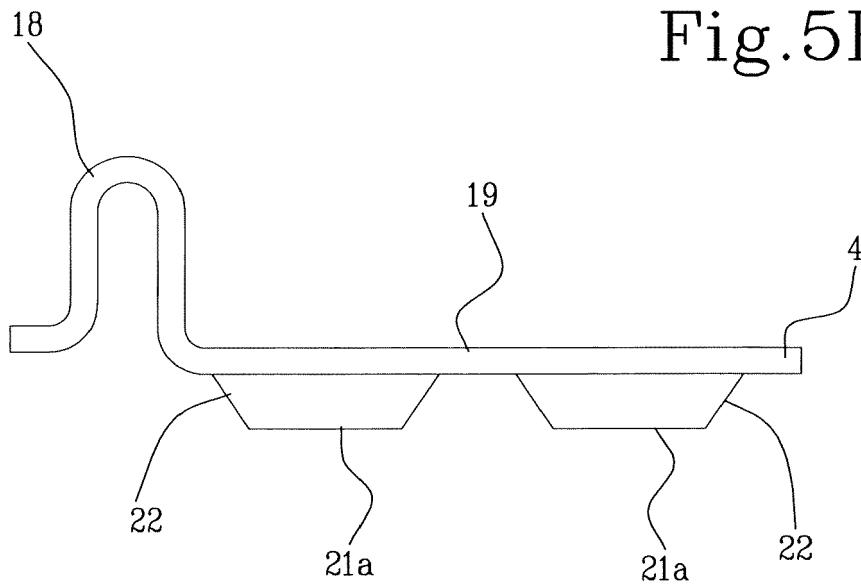
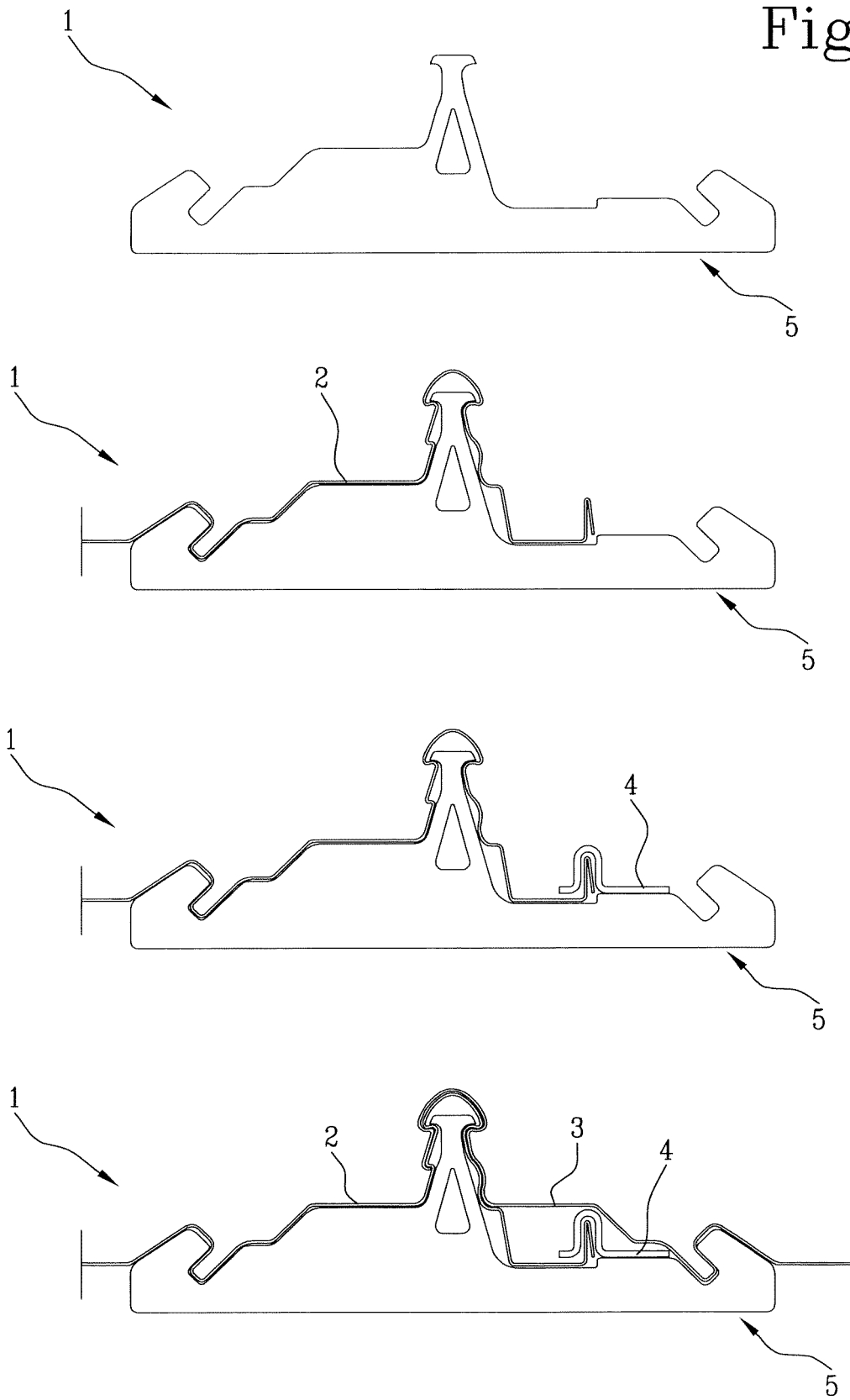

Fig.6





EUROPEAN SEARCH REPORT

Application Number
EP 19 42 5080

5

10

15

20

25

30

35

40

45

50

55

DOCUMENTS CONSIDERED TO BE RELEVANT			
Category	Citation of document with indication, where appropriate, of relevant passages	Relevant to claim	CLASSIFICATION OF THE APPLICATION (IPC)
X A	US 4 495 743 A (ELLISON BURLAN E [US] ET AL) 29 January 1985 (1985-01-29) * figures 13-14 *	1,13,15 2-12	INV. E04D3/363 E04D3/361
X A	----- KR 200 184 000 Y1 (PO HANG IRON & STEEL [KR]; INST OF IND SCIENCE POHANG [KR]) 1 June 2000 (2000-06-01) * figure * *	1,13,15 2-12	
X A	----- KR 2009 0012511 U (LEE S I) 8 December 2009 (2009-12-08) * paragraph [0005] *	1,13-15 2-12	
X	----- GB 2 428 051 A (RIGIDAL SYSTEMS LTD [GB]) 17 January 2007 (2007-01-17) * figure 2 *	1,15	
X	----- US 3 958 387 A (KANDABASHI SADA0) 25 May 1976 (1976-05-25) * figures 3,4 *	1	
X	----- US 2005/055903 A1 (GREENBERG PERCY [US]) 17 March 2005 (2005-03-17) * figures 2-5 *	1	TECHNICAL FIELDS SEARCHED (IPC) E04D
X A	----- EP 2 803 781 A1 (TECNOCOPERTURE TANGORRA S R L [IT]) 19 November 2014 (2014-11-19) * paragraph [0019]; figure 8 *	1,11,12, 14,15	
A	----- WO 2014/181153 A1 (ISCOM S P A [IT]) 13 November 2014 (2014-11-13) * figure 4 *	10	
A	----- KR 2007 0109021 A (MIYA TECH INC [JP]) 15 November 2007 (2007-11-15) * figure 3 *	11,12	

The present search report has been drawn up for all claims			
Place of search The Hague		Date of completion of the search 16 April 2020	Examiner Leroux, Corentine
CATEGORY OF CITED DOCUMENTS X : particularly relevant if taken alone Y : particularly relevant if combined with another document of the same category A : technological background O : non-written disclosure P : intermediate document		T : theory or principle underlying the invention E : earlier patent document, but published on, or after the filing date D : document cited in the application L : document cited for other reasons ----- & : member of the same patent family, corresponding document	

EPO FORM 1503 03.82 (P04C01)

ANNEX TO THE EUROPEAN SEARCH REPORT
ON EUROPEAN PATENT APPLICATION NO.

EP 19 42 5080

5

This annex lists the patent family members relating to the patent documents cited in the above-mentioned European search report. The members are as contained in the European Patent Office EDP file on The European Patent Office is in no way liable for these particulars which are merely given for the purpose of information.

16-04-2020

10

15

20

25

30

35

40

45

50

55

Patent document cited in search report	Publication date	Patent family member(s)	Publication date
US 4495743 A	29-01-1985	NONE	

KR 200184000 Y1	01-06-2000	NONE	

KR 20090012511 U	08-12-2009	NONE	

GB 2428051 A	17-01-2007	NONE	

US 3958387 A	25-05-1976	JP S5322430 Y2 JP S50122115 U US 3958387 A	10-06-1978 06-10-1975 25-05-1976

US 2005055903 A1	17-03-2005	NONE	

EP 2803781 A1	19-11-2014	EP 2803781 A1 ES 2614188 T3 PL 2803781 T3	19-11-2014 30-05-2017 31-05-2017

WO 2014181153 A1	13-11-2014	CN 105339567 A EA 201592062 A1 EP 2994583 A1 HK 1221000 A1 US 2016130815 A1 WO 2014181153 A1	17-02-2016 31-03-2016 16-03-2016 19-05-2017 12-05-2016 13-11-2014

KR 20070109021 A	15-11-2007	NONE	
