



(11) **EP 3 822 537 A1**

(12) **EUROPEAN PATENT APPLICATION**

(43) Date of publication:
19.05.2021 Bulletin 2021/20

(51) Int Cl.:
F21V 21/02 (2006.01) **F21V 21/14 (2006.01)**
F21V 21/34 (2006.01)

(21) Application number: **20207652.7**

(22) Date of filing: **13.11.2020**

(84) Designated Contracting States:
AL AT BE BG CH CY CZ DE DK EE ES FI FR GB GR HR HU IE IS IT LI LT LU LV MC MK MT NL NO PL PT RO RS SE SI SK SM TR
Designated Extension States:
BA ME
Designated Validation States:
KH MA MD TN

(72) Inventors:
• **TREVISANELLO, LORENZO**
35020 BRUGINE (IT)
• **FERRARESSO, MATTEO**
35020 BRUGINE (IT)
• **MAZZOLA, CHRISTIAN**
35020 BRUGINE (IT)

(30) Priority: **15.11.2019 IT 201900021318**

(74) Representative: **Feltrinelli, Secondo Andrea**
APTA S.r.l.
Patent Department
Via Ca' di Cozzi, 41
37124 Verona (IT)

(71) Applicant: **Arianna S.p.A.**
35020 Brugine (PD) (IT)

(54) **UNIVERSAL BRACKET FOR LIGHTING APPLIANCES**

(57) A universal bracket (1) for lighting appliances, which can be connected to a structural and/or plant element (C) of a vehicle tunnel, an underpass, or the like, in which the element (C) comprises a substantially "U"-shaped profile comprising, in turn, a bottom (C1) from which two opposite lateral sides (C2) rise, said lateral sides (C2) ending with respective edges (C3). The bracket (1) comprises a support (2), a first hooking element (3) and a second hooking element (4), associated with the support (2) in a sliding way so as to be translatable, with respect to the support (2), along the same first translation direction (A); each of the aforementioned first hooking element (3) and second hooking element (4) comprise a respective terminal portion (15) configured so as

to bind to the respective edge (C3) of the element (C); the support (2) further comprises connecting means (5) to one or more lighting appliances, or to support means for one or more lighting appliances. The support (2) comprises first, second selective locking members (16a, 16b), respectively, of the first hooking element (3) and of the second hooking element (4), configured to lock the first hooking element (3) and the second hooking element (4), with respect to the support (2) and along the first translation direction (A), in a plurality of positions between a position of minimum opening and maximum opening, so as to obtain different configurations of the bracket (1) to adapt to elements (C) of different sizes and geometries.

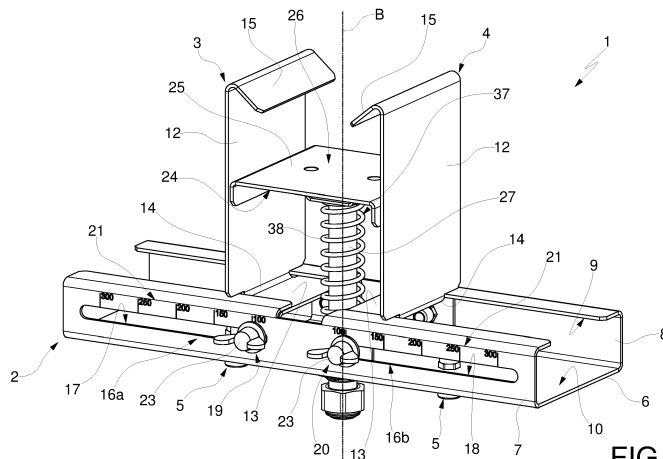

FIG. 1

EP 3 822 537 A1

Description

TECHNICAL FIELD OF THE INVENTION

[0001] The present invention concerns a universal bracket for lighting appliances.

[0002] More specifically, the present invention concerns a universal bracket for the installation of lighting appliances.

[0003] Even more in detail, the present invention concerns a universal bracket for the installation of lighting appliances inside vehicle tunnels, underpasses, and the like.

BACKGROUND ART

[0004] In lighting systems for vehicle tunnels, underpasses, and the like, various technical solutions are used for the installation and fixing of the lighting appliances to the existing structures.

In most situations, structural and/or plant elements already installed inside the tunnel, underpass, or similar are used to fix the lighting appliances; in particular, the cable-holder duct (also called walkway) fixed to the ceiling of the structure, or to one of the walls of the same, if present, is very frequently exploited.

For this purpose, metal brackets are used, which allow to obtain a permanent and reliable fixing of the lighting appliances to the duct.

Usually, the installation of lighting appliances takes place inside tunnels, underpasses, and the like, where road traffic cannot be absolutely stopped or diverted, therefore traffic restrictions must be applied.

Such limitations typically occur through a reduction in carriageways, which often cause considerable inconvenience to motorists, and which can also negatively affect the safety conditions in the tunnel.

For these reasons, installation operations must take place in the shortest possible time. The solutions currently used, therefore, are devised to allow the quick coupling of the bracket to the duct, for example by using snap fastening means with springs, levers, or the like, in order to require manual intervention as quick and easy as possible.

[0005] It must also be considered that, in the existing panorama of vehicular tunnels, underpasses, or the like, there are very different sized cable-holder ducts.

In fact, these ducts, considering their cross section, differ considerably in height, width and upper profile.

Since lighting maintenance operations take place very often in rather dated tunnels or underpasses, it is rather difficult, for installers and bracket manufacturers, to find information on the geometric characteristics of the aforementioned ducts: these characteristics become fully known only in the moment in which action is actually taken in the existing structure.

This can lead to considerable downtime between the moment in which the dimensions of the duct are measured

and the moment of installation as, in essence, it is necessary to make the brackets to measure based on the characteristics of the duct itself.

Another drawback is the fact that the fixed brackets, and therefore made to measure according to the characteristics of the duct, have mechanical tolerances that do not allow great flexibility, which instead would be necessary and important in the presence of dated ducts and installation situations with variable geometries.

OBJECTS OF THE INVENTION

[0006] The technical aim of the present invention is to improve the state of the art in the field of brackets for fixing lighting appliances.

[0007] Within such technical aim, it is an object of the present invention to develop a universal bracket for lighting appliances that allows to overcome the previously mentioned drawbacks.

[0008] Another object of the present invention is to provide a universal bracket for lighting appliances that can be quickly and easily installed on structural and/or plant elements, such as cable-holder ducts or the like, of different sizes and geometries.

[0009] A further object of the present invention is to make available a universal bracket for lighting appliances of immediate and intuitive use.

[0010] Another object of the present invention is to provide a universal bracket for lighting appliances which is constructively simple and economical.

[0011] Another object of the present invention is to provide a universal bracket for lighting appliances that is safe and reliable in connection to the structural and/or plant element, such as a cable-holder duct or the like.

[0012] This aim and these objects are all achieved by the universal bracket for lighting appliances according to the attached claim 1.

[0013] The universal bracket can be connected to a structural and/or plant element of a vehicle tunnel, an underpass, or the like (for example a cable-holder duct, or the like), in which the aforementioned element comprises a substantially "U" shaped profile comprising, in turn, a bottom from which two opposite lateral sides rise; the aforesaid lateral sides end with respective edges.

[0014] The bracket comprises a support, a first hooking element and a second hooking element, associated with the support in a sliding manner so as to be translatable, with respect to the support, along the same first translation direction.

[0015] Each of the aforementioned first hooking element, and second hooking element, includes a respective terminal portion configured so as to bind to the respective edge of the element; the support further comprises connection means to one or more lighting appliances, or to supporting means for one or more lighting appliances, indifferently.

[0016] According to the invention, the support comprises first, second selective locking members, respectively

of the first hooking element and of the second hooking element, configured to lock each of the aforementioned first hooking element, and second hooking element, with respect to the support and along the aforementioned first translation direction, in a plurality of positions comprised

between a position of minimum opening and maximum opening, so as to obtain different configurations of the bracket, to adapt to elements of different sizes and geometries.

[0017] Thanks to this solution, the bracket can adapt, very easily, to structural and/or plant elements, such as cable-holder ducts or the like, of different sizes and geometries, thus obtaining a solid and safe installation, and which does not require further adaptations or adjustments.

[0018] According to another aspect of the invention, the bracket comprises a pressure element, associated with the support, configured so as to abut against the lower face, in use, of the bottom of the structural and/or plant element.

[0019] The pressure element allows obtaining a stable and safe coupling of the bracket to the structural and/or plant element of the tunnel or underpass, distinguished by the elimination of any mechanical play between the support and the bottom of the same, regardless of the size and geometry of the element.

[0020] In particular, the invention provides two versions of the bracket.

[0021] In a first version, the first and second selective locking members are of the completely manual adjustment type.

[0022] In the second version the first, second selective locking members are of the type with automatic locking in the desired position, which allow the installer to selectively move the first hooking element, and the second hooking element, along the support, and along the first translation direction, in a plurality of positions, each of which is stable: in fact, each of these positions is maintained until the installer voluntarily intervenes to unlock it, so as to free the hooking elements.

[0023] The dependent claims refer to preferred and advantageous embodiments of the invention.

BRIEF DESCRIPTION OF THE DRAWINGS

[0024] These and further advantages will be better understood by every person skilled in the art from the following description and the attached drawings, given as a non-limiting example, in which:

Figure 1 is a perspective view of the universal bracket, according to the invention;

Figure 2 is a front view of the bracket, in two different use configurations;

Figure 3 is a front view of the bracket, hooked to a cable-holder duct of a tunnel, an underpass, or the like;

Figure 4 is a front view of the bracket in a certain

configuration of use;

Figure 5 is a front view of the bracket, in the configuration of use of Figure 4, hooked to a cable-holder duct of a tunnel, an underpass, or the like;

Figure 6 is a side view of the bracket;

Figure 7 is a front view of the bracket, sectioned along the plane VII-VII of Figure 6;

Figure 8 is a perspective view of the universal bracket, according to another embodiment of the invention;

Figure 9 is a front view of the bracket, according to the embodiment of Figure 8;

Figure 10 is a front view of the bracket, according to the embodiment of Figure 8, hooked to a cable-holder duct of a tunnel, an underpass, or the like;

Figure 11 is a side view of the bracket according to the embodiment of Figure 8;

Figure 12 is a front view of the bracket according to the embodiment of Figure 8, sectioned along the plane XII-XII of Figure 11;

Figure 13 is a detail of Figure 12.

EMBODIMENTS OF THE INVENTION

[0025] With reference to the attached figures, the reference number 1 generally indicates a universal bracket for lighting appliances according to the present invention. The bracket 1 according to the present invention can be connected to a structural and/or plant element C of a vehicle tunnel, an underpass or the like.

More in detail, in the following description, and in the attached figures, reference is made to a structural and/or plant element consisting of a cable-holder duct C of a vehicle tunnel, an underpass, or the like, to which lighting appliances are very frequently fixed.

In any case, it is emphasized that this is an illustrative and non-limiting example: consequently, in the following description, any reference to the cable-holder duct C is to be understood, in a more general sense, to any structural and/or plant element with similar characteristics.

As illustrated, for example, in Figure 3, a typical cable-holder duct C of a vehicle tunnel, an underpass, or the like, comprises a substantially "U" shaped profile, comprising, in turn, a bottom C1 from which two opposite lateral sides C2 rise.

The two lateral sides C2 end with respective edges C3, for example folded edges.

The type of lighting appliance, or appliances, associated with the bracket 1, according to the present invention, can be any, without limitations to the purposes of the present invention.

The bracket 1 includes a support 2.

Furthermore, the bracket 1 comprises a first hooking element 3 and a second hooking element 4.

The first hooking element 3 and the second hooking element 4 are associated with the support 2.

More in detail, the first hooking element 3 and the second hooking element 4 are associated with the support 2 in

a sliding manner.

As shown schematically in Figure 2, the first hooking element 3 and the second hooking element 4 are both slidable, with respect to the support 2, along the same first translation direction A.

The first hooking element 3 and the second hooking element 4 are associated with the support 2 so as to be opposed to each other (in a symmetrical, or mirrored, way).

Again, with reference to Figure 2, the support 2 defines a center plane P.

The center plane P is perpendicular to the first translation direction A of the first hooking element 3 and of the second hooking element 4.

The first hooking element 3 and the second hooking element 4 are configured in such a way as to bind, on opposite sides, to the lateral sides C2 of the structural and/or plant element C, as better described below.

The support 2 comprises connecting means 5 to one or more lighting appliances, or to supporting means for one or more lighting appliances, indifferently.

The aforesaid connecting means 5 are provided in the lower face, in use, of the support 2.

By means of the aforementioned connecting means 5, one or more lighting appliances (directly, or by means of respective supporting means) can be fixed, in a hanging manner, to the support 2.

In the attached figures, the lighting appliance, or lighting appliances, are not shown for simplicity.

For reasons of equilibrium, the connecting means 5 are configured, in the support 2, in a symmetrical, or specular, way with respect to the center plane P of the support 2 itself.

The connecting means 5 can be, for example, of the screw type, or of any other type, without limitations.

The support 2 comprises a profile with a substantially "C" cross section.

[0026] More in detail, this profile of the support 2 comprises a first wall 6 (which constitutes its bottom), a second wall 7 and a third wall 8, connected to the first wall 6 on opposite sides; the second wall 7 and the third wall 8 are folded inwards, so as to identify, between the respective end edges, an opening 9 (which, in use, faces upwards).

The walls 6,7,8 also define an internal compartment 10 of the support 2, which is accessed through the opening 9.

The opening 9 of the support 2 extends parallel to the first translation direction A: the function of this opening 9 is to allow the movement of the first hooking element 3 and of the second hooking element 4 with respect to the support 2, along the aforementioned first translation direction A.

The connecting means 5 can be provided in the first wall 6; for example, these connecting means 5, if they are of the screw type, can comprise threaded holes made in the first wall 6, or nut screws shaped by (or fixed to) the first wall 6, in which respective screws 11, or the like,

which hold the lighting appliance, engage.

The first hooking element 3 and the second hooking element 4 are constructively identical.

However, in some embodiments of the invention, any constructive differences between the first hooking element 3 and the second hooking element 4 are not excluded, in relation to specific application needs.

In addition, the first hooking element 3 and the second hooking element 4 are mounted, in the support 2, in a mirror image of each other, with respect to the center plane P.

The first, second hooking element 3,4 each comprise a main portion 12, which, as better described below, has the function of achieving the connection to the structural and/or plant element C.

Each of the first, second hooking element 3,4 also comprises a coupling portion 13 to the support 2.

The main portion 12 and the coupling portion 13 are associated, with each other, through a connection portion 14.

The coupling portion 13 is associated with the main portion 12 so that, in use, it faces inside of the support 2, that is towards the center plane P.

[0027] More in detail, the coupling portion 13 comprises a profile, or a section of profile, with a substantially "C" cross section, and it is configured in such a way as to be inserted, in a sliding manner, inside the compartment 10 of the support 2; the coupling portion 13 is inserted inside the support 2 with the respective opening, in use, facing downwards.

With particular reference to Figure 6, the connecting portion 14 is shaped so as to have (in a plane perpendicular to the first translation direction A) a width smaller than that of the opening 9 of the support 2, so as to be able to freely slide along the latter.

The main portion 12 is substantially flat, having quadrangular shape (for example square or rectangular).

Each first, second hooking element 3,4 includes a respective terminal portion 15, configured so as to bind to the respective edge C3 of the structural and/or plant element C.

The aforementioned terminal portion 15 is provided in the main portion 12 of the first, second hooking element 3,4.

More in detail, each terminal portion 15 is folded, so as to form a certain acute angle with the plane in which the main portion 12 lies.

The terminal portion 15, shaped in this way, can cling to the respective edge C3 of the structural and/or plant element C, so as to obtain a hanging support of the bracket 1.

In the embodiment of the invention illustrated in the figures, the first hooking element 3 and the second hooking element 4 are made from a single sheet of bent metal sheet, suitably cut.

This is a quick and economical constructive solution, which however allows to obtain a light and resistant component, with the required features.

The first hooking element 3 and the second hooking element 4 are inserted, inside the compartment 10 of the support 2, from opposite sides.

According to an aspect of the invention, the support 2 comprises first selective locking members 16a of the first hooking element 3, and second selective locking members 16b of the second hooking element 4.

The aforementioned first, second selective locking members 16a, 16b allow to obtain different configurations of the bracket 1, to fit to structural and/or plant elements C of different sizes and geometries, as better explained below.

In fact, as can be seen, for example, in Figures 2,3,5, the first hooking element 3 and the second hooking element 4 can be moved, with respect to the support 2, from respective positions of minimum opening (Figure 5) to respective positions of maximum opening (Figure 3).

The first, second selective locking members 16a, 16b allow to lock, respectively, the first hooking element 3 and the second hooking element 4 with respect to the support 2, in a plurality of positions comprised between the aforementioned extreme positions of maximum opening and minimum opening.

The first, second selective locking members 16a, 16b can be of the manual type.

More in detail, the first, second selective locking members 16a, 16b comprise, respectively, a first slot 17 and a second slot 18, made in the support 2.

[0028] Furthermore, the first, second selective locking members 16a, 16b comprise, respectively, first screw means 19 and second screw means 20.

The first screw means 19 and the second screw means 20 are configured to constrain, respectively, the first hooking element 3 and the second hooking element 4 in respective positions along the first slot 17 and the second slot 18, at user's discretion.

The first slot 17 and the second slot 18 are made in the second wall 7 (or in the third wall 8) of the support 2.

The first slot 17 and the second slot 18 are aligned with each other, or substantially aligned with each other, and are arranged parallel to the first translation direction A.

Along the second wall 7 (or the third wall 8) of the support 2, and at the first slot 17 and second slot 18, respective millimeter scales 21, or the like, can be provided, which allow the installer to place the first hooking element 3, and the second hooking element 4, in the desired positions along the support 2.

The first screw means 19 and the second screw means 20 are constructively identical to each other, although in some embodiments of the invention they could be different, in relation to specific application requirements.

The first, second screw means 19,20 comprise a nut screw 22, provided in the coupling portion 13 of the first, second hooking element 3,4 (Figures 6,7).

Furthermore, the first, second screw means 19,20 comprise an adjustment screw 23, provided with a manually operable head.

For example, the adjustment screw 23 can be of the butterfly type, or the like.

terfly type, or the like.

The adjustment screw 23 is suitable to engage in the nut screw 22, so as to lock, by friction, the first, second hooking element 3,4 in the desired position along the first, second slot 17,18.

The nut screw 22 can be constituted by a threaded bushing, or the like, engaged in a lateral hole provided in the coupling portion 13.

As shown, in particular, in Figures 1 and 6, the coupling portion 13 of each hooking element 3,4 can comprise two nut screws 22, provided, in a mirror image with respect to a longitudinal center plane, on opposite sides of the coupling portion 13; in this way, each hooking element 3,4 is made completely reversible (i.e., indifferently, right or left) when mounted in the same bracket 1, or even in different brackets.

According to another aspect of the invention, the bracket 1 comprises a pressure element 24.

The pressure element 24 is associated with the support 2.

In addition, the pressure element 24 is configured in such a way as to abut against the lower face, in use, of the bottom C1 of the structural and/or plant element C (cable-holder duct).

As will become clearer afterwards, the presence of the pressure element 24 allows to obtain a safe and stable coupling of the bracket 1 to the structural and/or plant element C; in this coupling, any mechanical play between the support 2 and the bottom C1 is eliminated, regardless of the size and geometry of the element C (in particular, regardless of the height of the lateral sides C2).

In other words, with the same dimensions of the first hooking element 3 and of the second hooking element 4, the pressure element 24 allows to obtain a solid, rigid, and play-free (and therefore not labile and accidentally movable) coupling of the bracket 1 to the structural and/or plant element C, regardless of the height of the lateral sides C2 of the latter.

[0029] The pressure element 24 is movable, with respect to the support 2, along a second translation direction B (as shown, in discontinuous section, in Figure 2). The second translation direction B of the pressure element 24 is perpendicular to the first translation direction A of the first hooking element 3 and of the second hooking element 4.

Furthermore, according to another aspect of the invention, the second translation direction B belongs to the center plane P of the support 2, essentially for reasons of symmetry and balance of the stresses applied to the bracket 1.

The pressure element 24 includes an operating portion 25, suitable to abut against the lower face, in use, of the bottom C1 of the structural and/or plant element C.

The operating portion 25 includes a pressing surface 26, which, in use, is in direct contact with the lower face of the bottom C1 of the structural and/or plant element C. Furthermore, the pressure element 24 comprises a stem 27, to which the operating portion 25 is connected.

The stem 27 is engaged, in a sliding way, inside a seat

28 provided in the support 2. More in detail, the seat 28 is provided in the first wall 6 of the support 2.

The seat 28 is defined by a bush 29, engaged in a respective hole made in the first wall 6 of the support 2.

The bush 29 is externally threaded, and it is locked in the respective hole by means of a first nut 30 screwed along its thread.

The stem 27 can have a cylindrical, or substantially cylindrical, shape.

The stem 27 includes a head 31, and an end 32, opposite the head 31.

The end 32 is threaded; along the end 32 a second nut 33 is screwed, which prevents the slipping of the stem 27 itself from the seat 28.

The operating portion 25 is substantially shaped like a sort of plate, the upper face of which defines the aforementioned pressing surface 26; the operating portion 25 can have folded side edges.

The head 31 of the stem 27 is connected to the operating portion 25.

More specifically, the operating portion 25 comprises a housing 34, within which the head 31 engages.

[0030] The housing 34 can be obtained, for example, by using a sheet metal element 35, suitably shaped, comprising a central hole with a diameter smaller than that of the head 31, so as to allow the stem 27 to pass, but not its extraction, so as to trap the head 31.

The sheet metal element 35 can be fixed to the operating portion 25, for example, by means of rivets 36, or with other fastening means such as weld seams, or the like. According to a further aspect of the invention, the pressure element 24 comprises at least one elastic member 37, configured to keep the operating portion 25 in contact against the lower face, in use, of the bottom C1 of the structural and/or plant element C. In the embodiment of the invention illustrated in the attached figures, the elastic member 37 comprises a helical cylindrical spring 38, inserted along the stem 27.

The spring 38 comprises a first end 39, which abuts on the bush 29.

In addition, the spring 38 includes a second end 40, which abuts on the operating portion 25: for example, the second end 40 abuts on the sheet metal element 35 which defines the housing 34.

Therefore, the elastic action of the spring 38 tends to move the operating portion 25 of the pressure element 24 away from the support 2, and therefore to keep the operating portion 25 in contact with the lower face, in use, of the bottom C1 of the structural and/or plant element C. The elastic member 37 could be of any other type suitable for this specific application, without limitations.

The way of use of the bracket 1 according to the invention is, in the light of what has been described, completely intuitive.

With reference, for example, to Figures 2-5, the bracket 1 is approached to the structural and/or plant element C (cable-holder duct) to which it must be fixed.

The first, second selective locking members 16a, 16b (in

particular, the first screw means 19 and the second screw means 20) are released, or loosened, so as to be able to freely translate the first hooking element 3 and the second hooking element 4 with respect to support 2.

5 For example, the first hooking element 3 and the second hooking element 4 can initially be brought into the maximum opening configuration, which allows the fixing to structural and/or plant elements C of greater dimensions, for greater ease of operation.

10 The pressure member 24, by action of the spring 38, is in the configuration (illustrated for example in Figure 4, or with a discontinuous line in Figure 2) in which the operating portion 25 is maximally distant from the support 2. Under optimal conditions, in this configuration, the distance between the pressing surface 26, and the terminal portions 15 of the first hooking element 3 and of the second hooking element 4, is less than the height of the lateral sides C2 of the structural element and/or plant C. By approaching the bracket 1 to the structural and/or plant element C, the operating portion 25 of the pressure element 24 abuts on the lower face, in use, of its bottom C1.

The first hooking element 3 and the second hooking element 4 are then approached, respectively, to the lateral sides C2.

The installer exerts a certain manual pressure on the support 2, upwards, in order to reduce the distance of the operating portion 25 from the support 2 itself, against the resistance of the spring 38.

30 This allows to engage the terminal portions 15, of the first hooking element 3 and of the second hooking element 4, above the edges C3 of the structural and/or plant element C: in this way, the bracket 1 is hooked and hung to element C.

35 At this point, having obtained the correct coupling configuration, the first, second selective locking members 16a, 16b are tightened by manually acting on the respective adjustment screws 23.

40 In this phase, the millimeter scales 21 can be of help if the width of the structural and/or plant element C, to which the bracket 1 is to be hooked, is known in advance.

The pressure element 24 prevents the bracket 1, once hooked to the structural and/or plant element C, from moving accidentally, as it allows to eliminate the mechanical play between the two parts; in addition, the pressure element 24 compensates for any dimensional differences existing between the various structural and/or plant elements C (mainly, differences in the height of the lateral sides C2).

45 As seen, the installation of the bracket 1 is quick and easy, and is not affected by the dimensional differences between the structural and/or plant elements C.

[0031] The eventual release of the bracket 1 is just as simple and fast, by carrying out the operations, described above, in reverse order.

55 Another embodiment of the invention is shown in Figures 8-13.

This embodiment differs from the previous one, mainly,

due to the conformation of the first hooking element 3, of the second hooking element 4, and also of the first, second selective locking members 16a, 16b respectively of the first hooking element 3 and of the second hooking element 4.

In this embodiment, the first selective locking members 16a and the second selective locking members 16b are of the type with automatic and stable locking in the desired position.

In other words, the first, second selective locking members 16a, 16b allow the installer to selectively move the first hooking element 3 and the second hooking element 4 along the support 2, and along the first translation direction A, towards the center plane P, in a plurality of positions, each of which is stable; in fact, each of these positions is maintained until the installer himself voluntarily intervenes to unlock it, as better described below. In this version of the invention, differently from the previous one, the coupling portion 13 of the first, second coupling element 3,4 is shaped and configured in such a way as to enclose (wrap) the support 2 externally.

Furthermore, the coupling portion 13 is associated with the main portion 12 so that, in use, it faces the ends of the support 2.

Also in this embodiment, the coupling portion 13 comprises a profile, or a section of profile, having a substantially "C"-shaped cross section; the coupling portion 13 is coupled to the support 2 with the respective opening, in use, facing downwards.

In this embodiment, the first, second selective locking members 16a, 16b comprise a respective ratchet locking mechanism.

More in detail, the first selective locking members 16a of the first hooking element 3 comprise a first rack 41; similarly, the second selective locking members 16b of the second hooking element 4 comprise a second rack 42. The first rack 41 and the second rack 42 are fixed to the first wall 6 of the support 2 (in particular to its upper face, in use).

Each rack 41,42 comprises a profile with a substantially "C" cross section, with opening facing the opening 9 of the support 2 (i.e., in use, facing upwards).

The teeth 43 of each rack 41,42 can be obtained along the side walls of the aforesaid profile; this solution allows to limit the weight of each rack 41,42.

The teeth 43 of each rack 41,42 are asymmetrical, along the first translation direction A; more in detail, each rack 41,42 has a substantially sawtooth configuration.

In fact, each tooth 43 comprises a straight side 44 and an inclined side 45 (see the detail in Figure 13).

The first rack 41 and the second rack 42 are fixed, to the support 2, in a mirror image with respect to its center plane P.

More in detail, the first rack 41 and the second rack 42 are arranged so that the inclined sides 45 of the respective teeth 43 each define an increasing ramp proceeding from the respective end of the support 2 towards the center plane P.

The first selective locking members 16a further comprise a first pawl 46, configured to engage between two consecutive teeth 43 of the first rack 41.

Similarly, the second selective locking members 16b comprise a second pawl 47, configured to engage between two consecutive teeth 43 of the second rack 42.

The first pawl 46 is articulated to the coupling portion 13 of the first hooking element 3, at a first articulation axis 48; the second pawl 47 is articulated to the coupling portion 13 of the second hooking element 4, at a second articulation axis 49.

More in detail, each coupling portion 13 of the first, second hooking element 3,4 includes two appendages 50 which, in use, extend inside the compartment 10 of the support 2.

The appendages 50 of each first, second hooking element 3,4 are identical and opposite to each other; they respectively support a first pivot pin 51 and a second pivot pin 52, respectively, of the first pawl 46 and of the second pawl 47.

Each first, second pawl 46,47 comprises a respective stop portion 53, and a manual actuation portion 54.

The stop portion 53 and the manual actuation portion 54 are located on opposite sides with respect to the first, second articulation axis 48,49.

The first selective locking members 16a comprise a first spring 55, configured to keep the first pawl 46 in the locking position of the first hooking element 3.

In the same way, the second selective locking members 16b comprise a second spring 56, configured to keep the second pawl 47 in the locking position of the second hooking element 4.

The first spring 55 and the second spring 56 are of the torsion type, and are inserted along a third pin 57 and a fourth pin 58 supported by the appendages 50, respectively, of the first hooking element 3 and of the second hooking element 4.

The two ends of each first, second spring 55,56 abut, respectively, on the stop portion 53 of each first, second pawl 46,47, and also on the lower face of the coupling portion 13 of the first, second hooking element 3,4.

Thanks to this expedient, each first, second pawl 46,47 is stably maintained in engagement between two consecutive teeth 43 of the first, second rack 41,42.

Therefore the installer, during the hooking operations of the bracket 1 to the structural and/or plant element C - and assuming to start from a configuration of maximum opening of the hooking elements 3,4 - can manually press the first, second hooking element 3,4 from the respective ends of the support 2 towards the center plane P; each of the aforementioned first, second hooking element 3,4 can move thanks to the fact that the respective first, second pawl 46,47 can jump from one tooth 43 to another, oscillating respectively around the first, second articulation axis 48,49 and overcoming the contrast action of the first, second spring 55,56.

In this way, each first, second hooking element 3,4 can reach the respective final installation position, in which

the respective terminal portion 15 engages on the respective edge C3 of the structural and/or plant element C. Each position reached by the first, second hooking element 3,4 is therefore stable since, thanks to the shape of the teeth 43 of the first, second rack 41,42, the retrograde motion of the same, towards the ends of the support 2, cannot occur except for the voluntary action of the installer.

To remove the bracket 1 from the structural and/or plant element C, in case of need (for example for maintenance or replacement reasons) the installer presses on the manual actuation portions 54 of the first, second pawl 46,47, in such a way to overcome the contrast of the first, second spring 55,56; in this way, the stop portions 53 of the first, second pawl 46,47 are disengaged, respectively, from the teeth 43 of the first, second rack 41,42, and consequently each first, second hooking element 3,4 can freely slide along support 2.

Another difference, compared to the previous embodiment, concerns the solution adopted for the abutment of the first end 39 of the spring 38 (see in particular Figure 12).

In this case, in fact, an additional sheet element 59 is used, suitably shaped and perforated for the passage of the stem 27, fixed inside the compartment 10 of the support 2 by rivets 60.

Compared to the previous embodiment, the solution according to this embodiment of the invention has the advantage of easier maneuverability of the bracket 1 in the phase of attachment to the structural and/or plant element C.

In fact, the correct position of the first hooking element 3 and of the second hooking element 4 is reached in a simple and quick way, even using only one hand, since, as said, it is sufficient to press each first, second hooking element 3, 4, one after the other, towards the center plane P of the support 2 to obtain a stable configuration of the bracket 1.

Also the possible unlocking operations of the bracket 1, for maintenance or replacement reasons, are equally simple and can be carried out with one hand only, since it is sufficient to press each manual actuation portion 54 to then be able to translate the respective first, second coupling element 3,4, along the support 2, away from the center plane P.

The invention, thus conceived, allows to achieve important technical advantages.

The bracket 1 can be fastened, in a simple and easy way, to structural and/or plant elements C of tunnels, underpasses, and the like, of variable dimensions and geometry, without having to make changes or adjustments during the installation phase.

The installation of the bracket 1 (or even its removal) therefore takes place very quickly: this is very important to avoid deviating vehicle traffic for prolonged times.

The adopted solution is also particularly cheap and simple from the construction point of view; also, the object maintenance is easy and quick.

The proposed solution is also constructively light and easy to handle, so as to facilitate the work of the installers. It has thus been seen how the invention achieves the proposed purposes.

The invention thus conceived is susceptible of numerous modifications and variations, all falling within the scope of the inventive concept.

Furthermore, all the details can be replaced by other technically equivalent elements. In practice, the materials used, as well as the contingent shapes and dimensions, may be any according to the requirements, without thereby departing from the scope of the protection of the following claims.

Claims

1. Universal bracket (1) for lighting appliances, connectable to a structural and/or plant element (C) of a vehicle tunnel, an underpass, or the like, said element (C) comprising a substantially "U" shaped profile comprising, in turn, a bottom (C1) from which two opposite lateral sides (C2) rise, said lateral sides (C2) ending with respective edges (C3), said bracket (1) comprising a support (2), a first hooking element (3) and a second hooking element (4), associated with said support (2) in a sliding way so as to be translatable, with respect to said support (2), along the same first translation direction (A), each of said first hooking element (3) and second hooking element (4) comprising a respective terminal portion (15) configured so as to be constrained to the respective edge (C3) of the element (C), said support (2) further comprising connecting means (5) to one or more lighting appliances, or to supporting means for one or more lighting appliances, **characterized in that** said support (2) comprises first, second selective locking members (16a, 16b), respectively, of said first hooking element (3) and of said second hooking element (4), configured to lock each of said first hooking element (3) and second hooking element (4), with respect to said support (2) and along said first translation direction (A), in a plurality of positions between a position of minimum opening and maximum opening, so as to obtain different configurations of the bracket (1) to adapt to elements (C) of different sizes and geometries.
2. Bracket (1) according to claim 1, comprising a pressure element (24) associated with said support (2), configured so as to abut against the lower face, in use, of the bottom (C1) of the structural and/or plant element (C).
3. Bracket (1) according to claim 2, wherein said pressure element (24) is movable, with respect to said support (2), along a second translation direction (B) perpendicular to said first translation direction (A).

4. Bracket (1) according to claim 3, wherein said pressure element (24) comprises an operating portion (25), suitable to abut against the lower face, in use, of the bottom (C1) of the structural and/or plant element (C), and a stem (27), to which said operating portion (25) is connected, said stem (27) being engaged, in a sliding manner, inside a seat (28) provided in said support (2). 5
5. Bracket (1) according to claim 4, wherein said pressure element (24) comprises at least one elastic member (37), configured to keep said operating portion (25) in contact with the lower face, in use, of the bottom (C1) of the structural and/or plant element (C). 10
6. Bracket (1) according to claim 5, wherein said elastic member (37) comprises a helical cylindrical spring (38), inserted along said stem (27) and included between said support (2) and said operating portion (25). 20
7. Bracket (1) according to one of the preceding claims, in which said first, second selective locking members (16a,16b) comprise a first slot (17) and a second slot (18) made in said support (2), aligned to each other, or substantially aligned to each other, and parallel to said first translation direction (A), and also first screw means (19) and second screw means (20), said first screw means (19) and said second screw means (20) being configured to constrain, respectively, said first hooking element (3) and said second hooking element (4) in respective positions along said first slot (17) and said second slot (18). 25
30
35
8. Bracket (1) according to claim 7, wherein said first, second screw means (19,20) comprise a respective nut screw (22) provided in said first, second hooking element (3,4), and a respective adjustment screw (23), equipped with a manually operated head. 40
9. Bracket (1) according to one of claims 1-6, wherein said first, second selective locking members (16a,16b) comprise a respective ratchet locking mechanism (41,42,46,47). 45
10. Bracket (1) according to claim 9, wherein said first, second selective locking members (16a,16b) comprise, respectively, a first rack (41) and a second rack (42) with substantially sawtooth configuration, fixed to said support (2) in a specular way with respect to its center plane (P), and also a first pawl (46) and a second pawl (47), configured to engage, respectively, between the teeth (43) of said first rack (41) and said second rack (42). 50
55
11. Bracket (1) according to claim 10, in which said first pawl (46) is articulated to said first hooking element (3) at a first articulation axis (48), and in which said second pawl (47) is articulated to said second hooking element (4) at a second articulation axis (49), each of said first, second pawl (46,47) comprising a respective stop portion (53), configured to engage, respectively, between the teeth (43) of said first rack (41) and of said second rack (42), and a respective manual actuation portion (54), said stop portion (53) and said manual actuation portion (54) being positioned on opposite sides with respect to said first, second articulation axis (48,49).
12. Bracket (1) according to claim 10 or 11, wherein said first, second selective locking members (16a,16b) comprise, respectively, a first spring (55) configured to keep said first pawl (46) in the locking position of said first hooking element (3) with respect to said support (2), and a second spring (56) configured to maintain said second pawl (47) in the locking position of said second hooking element (4) with respect to said support (2).

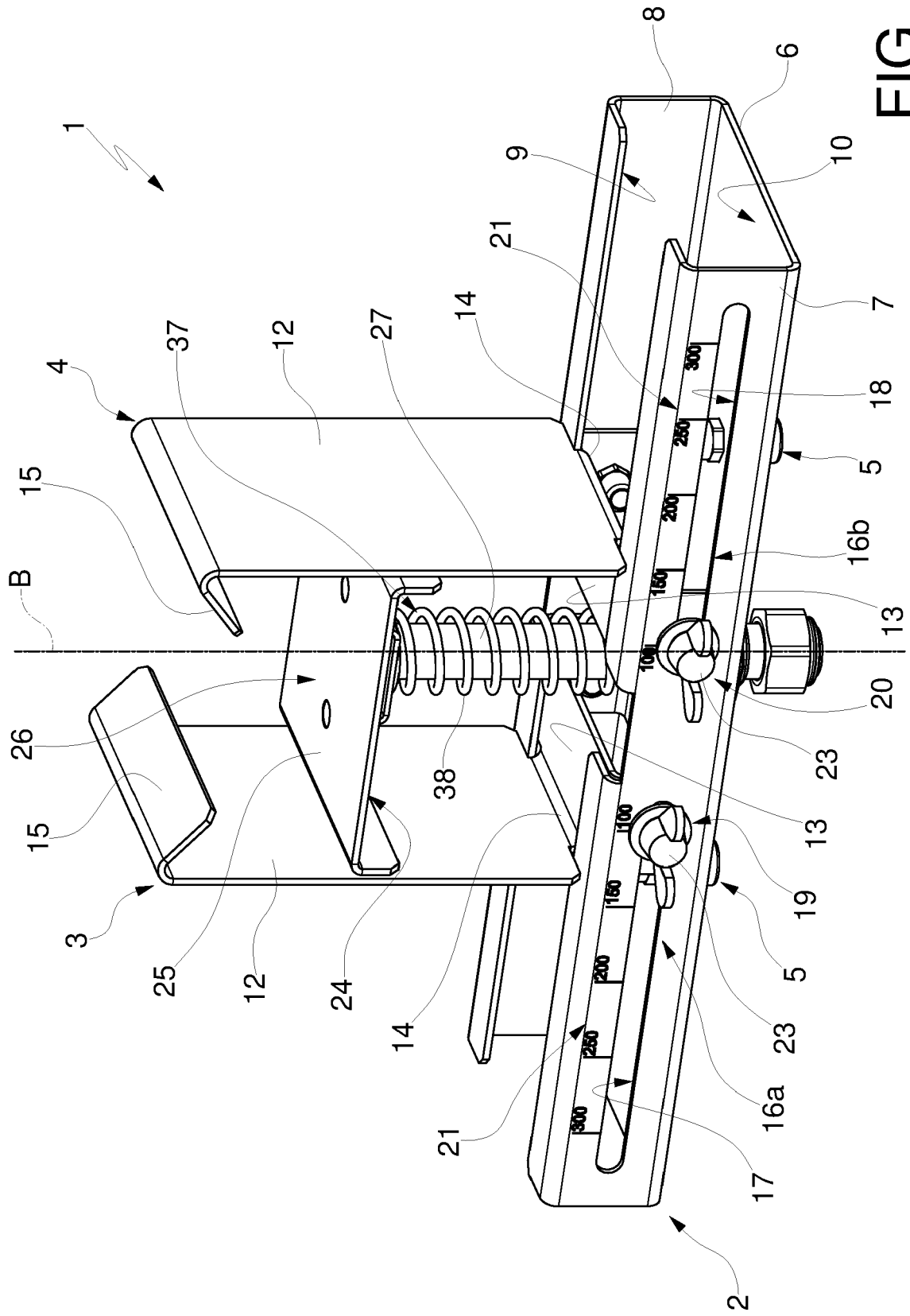

FIG. 1

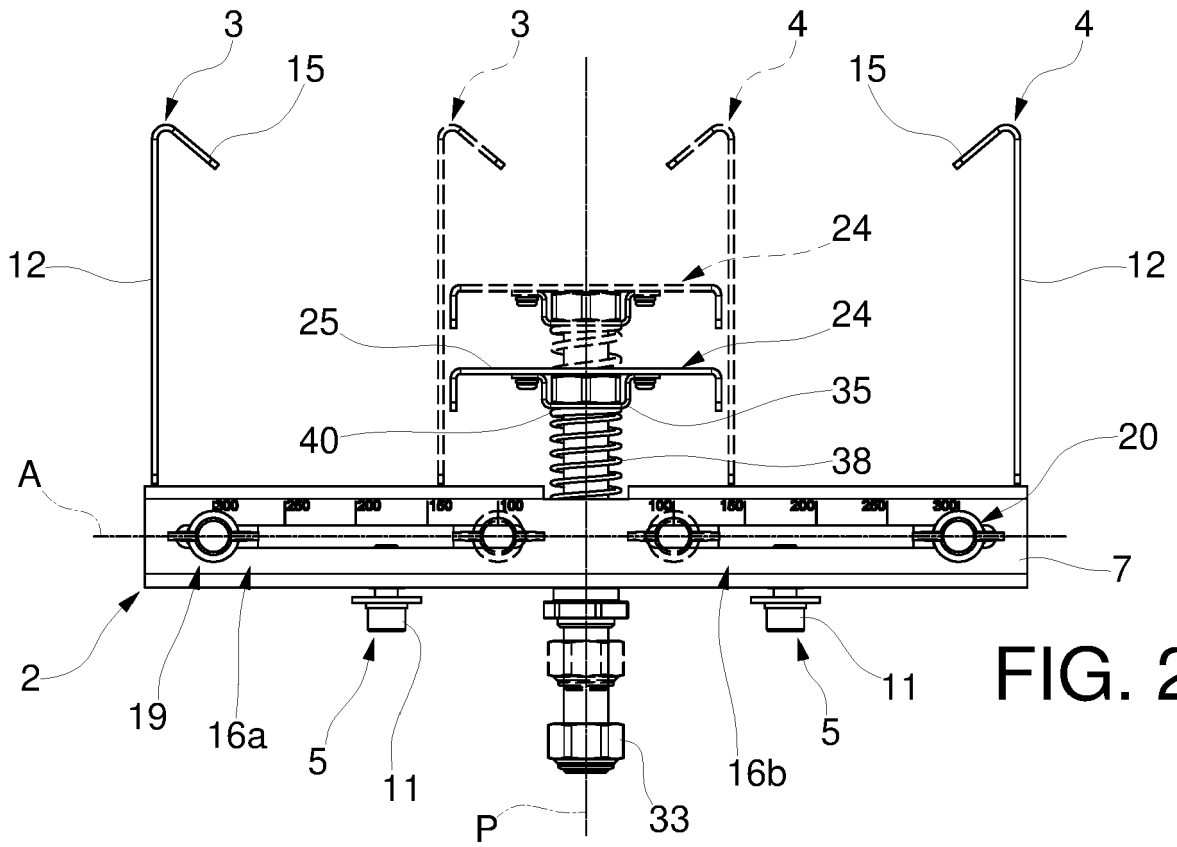

FIG. 2

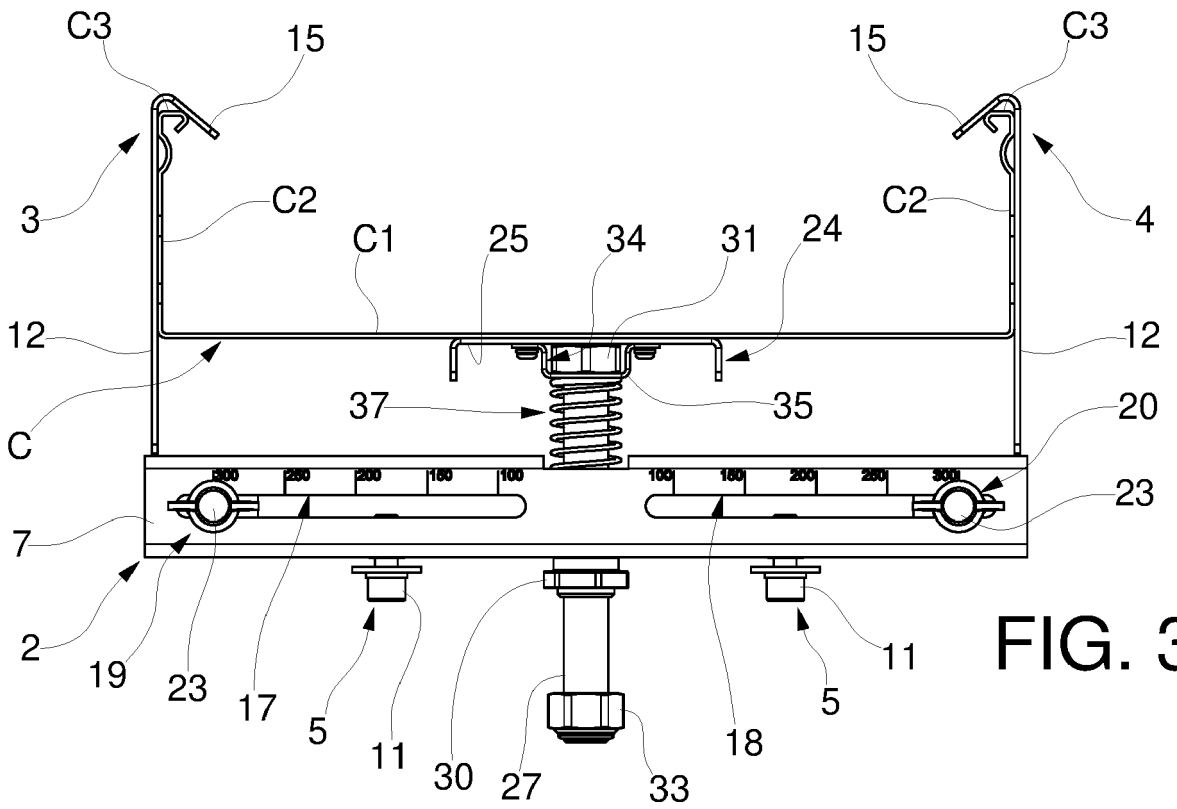

FIG. 3

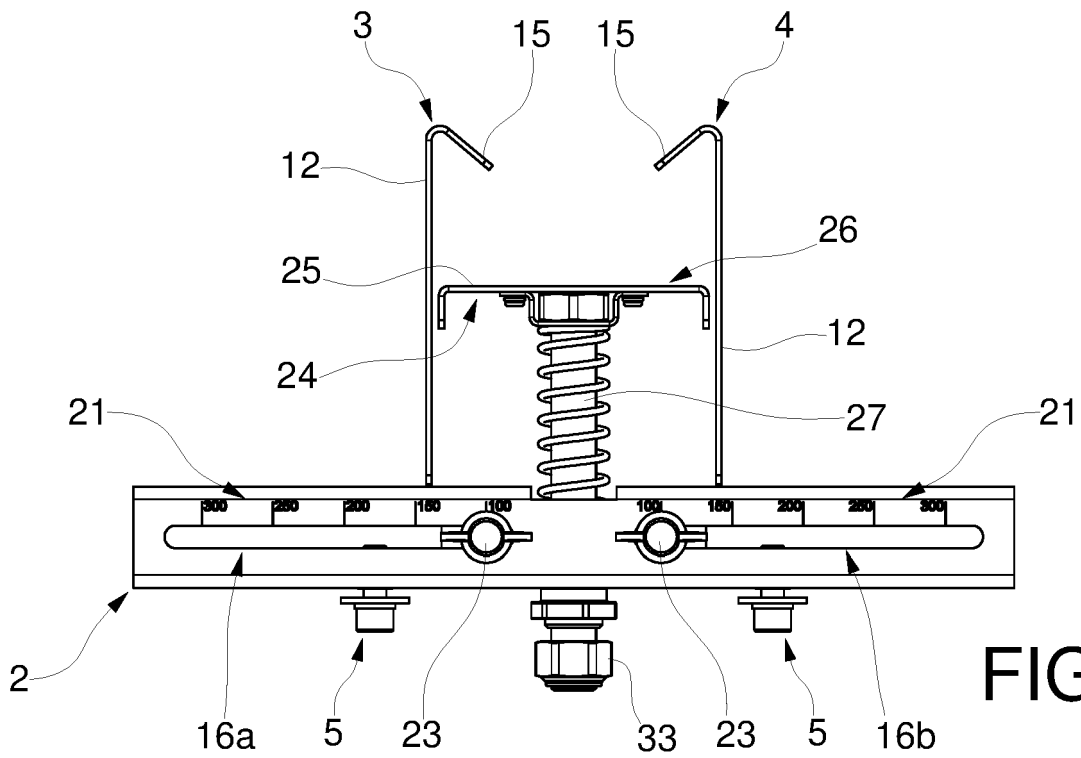

FIG. 4

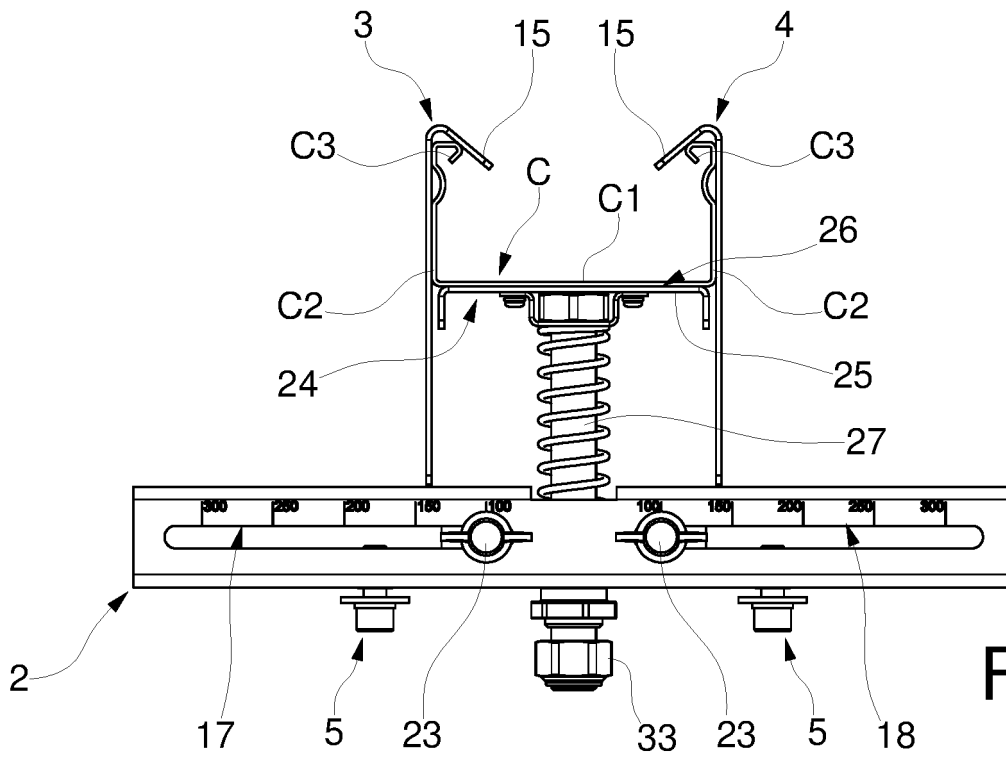
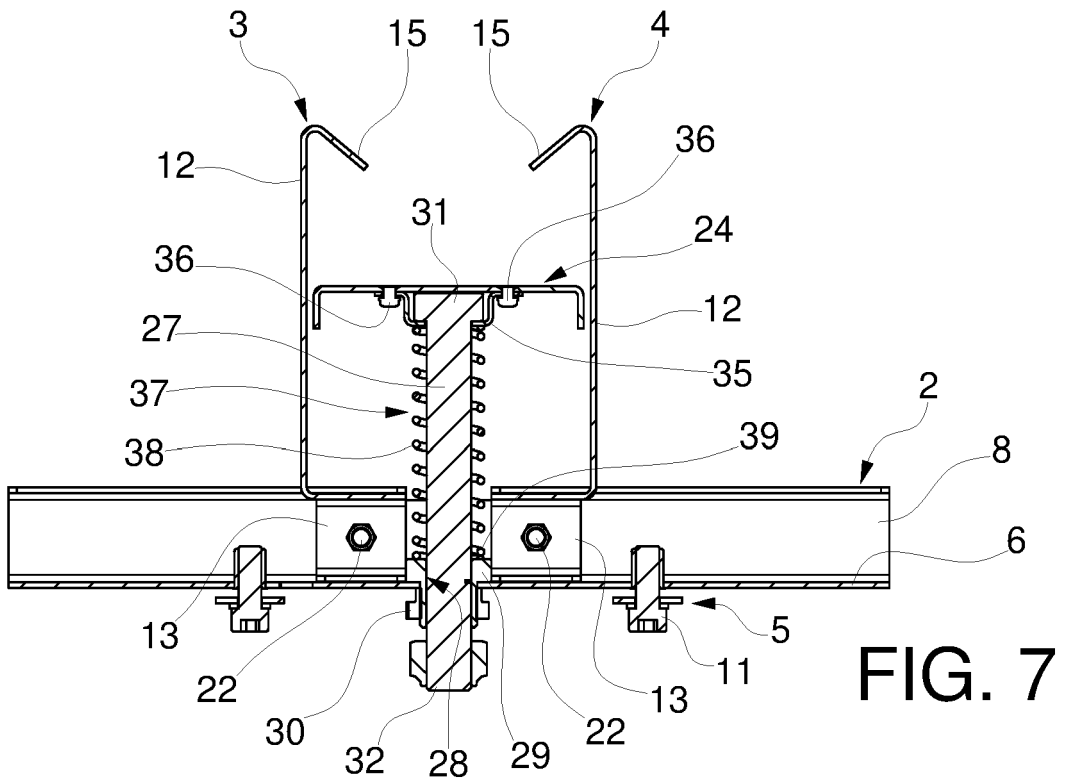
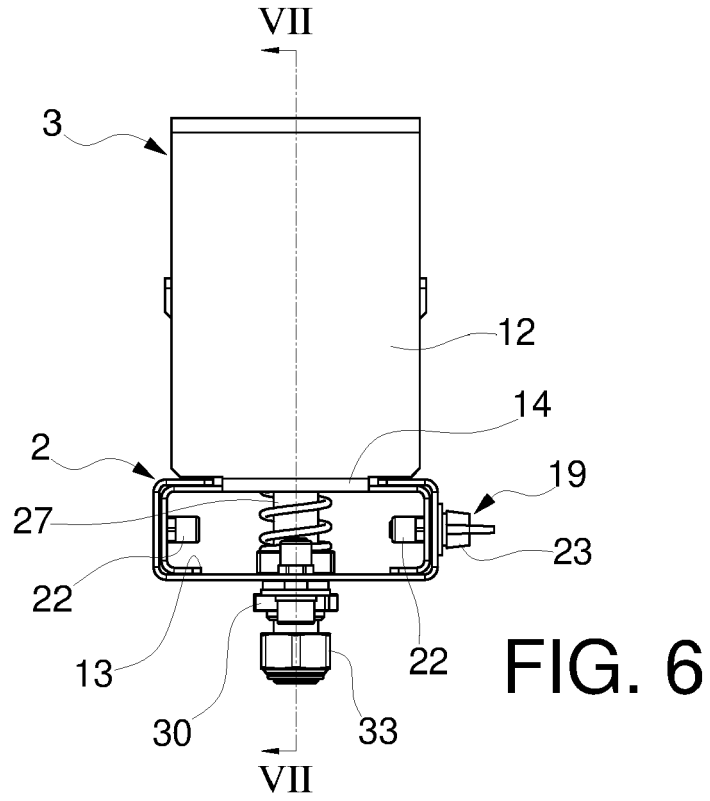

FIG. 5



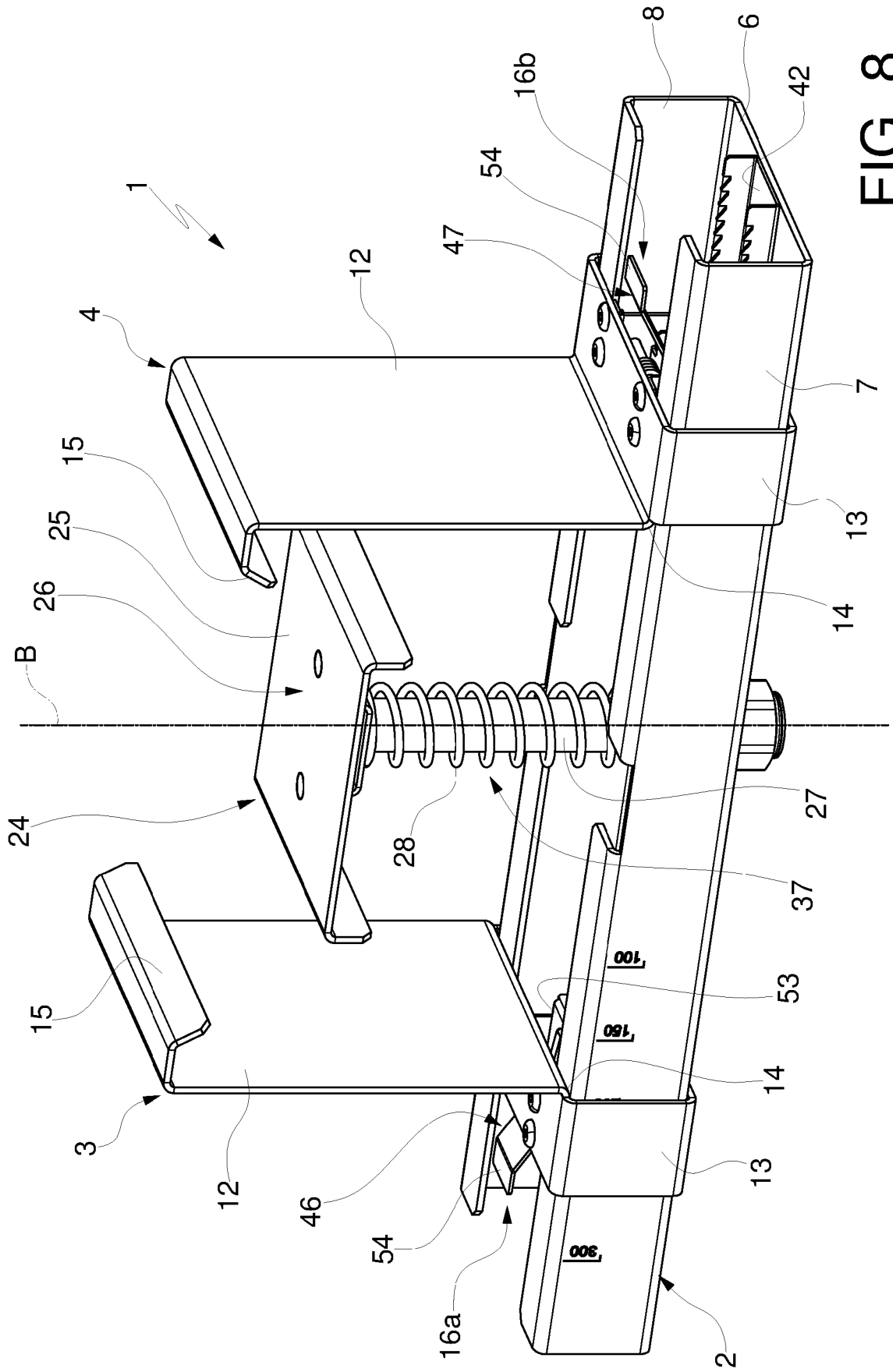

FIG. 8

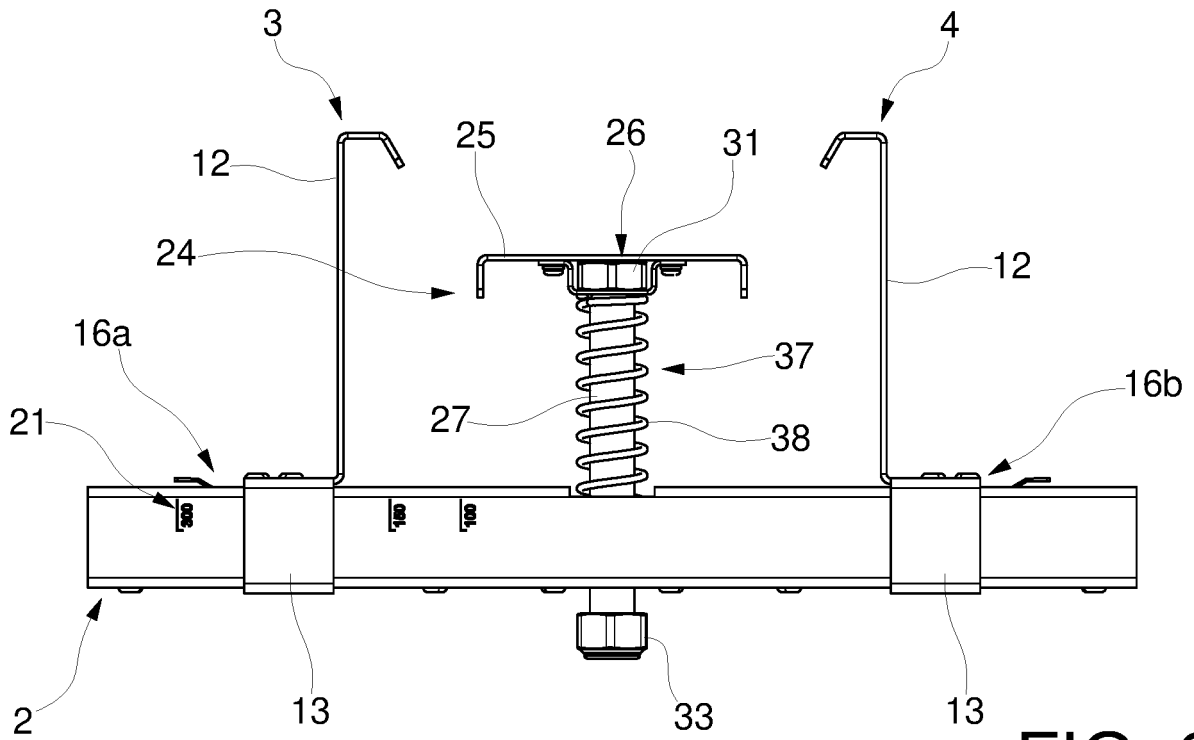

FIG. 9

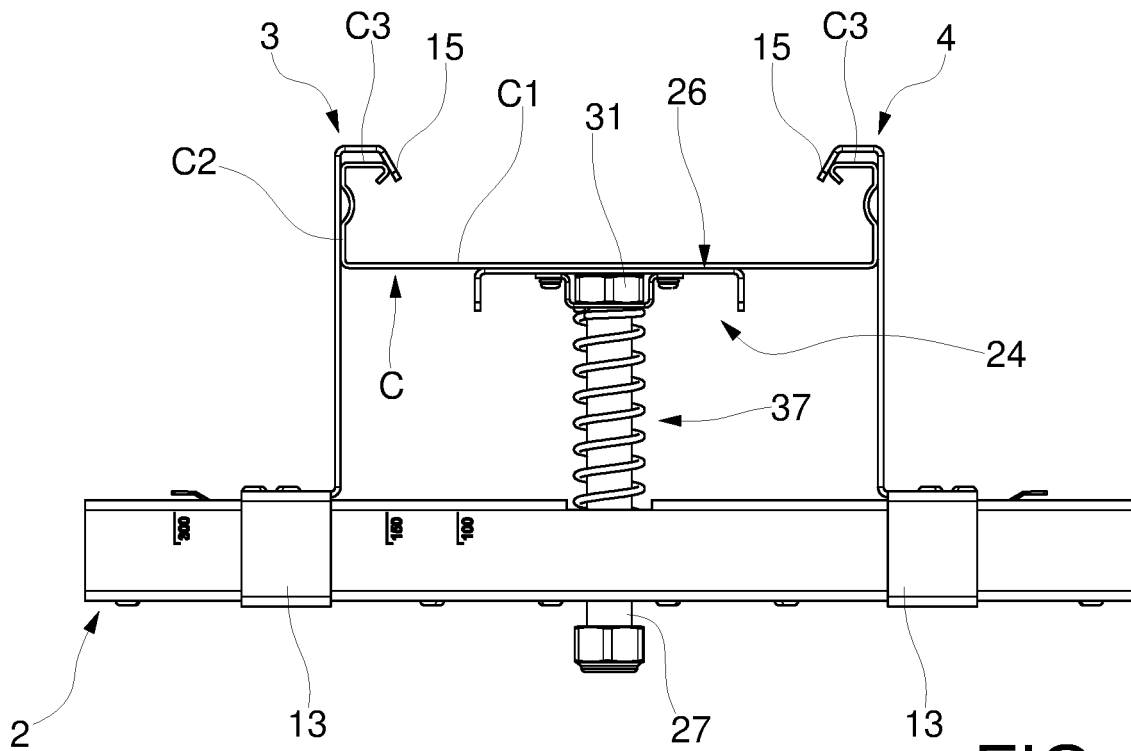

FIG. 10

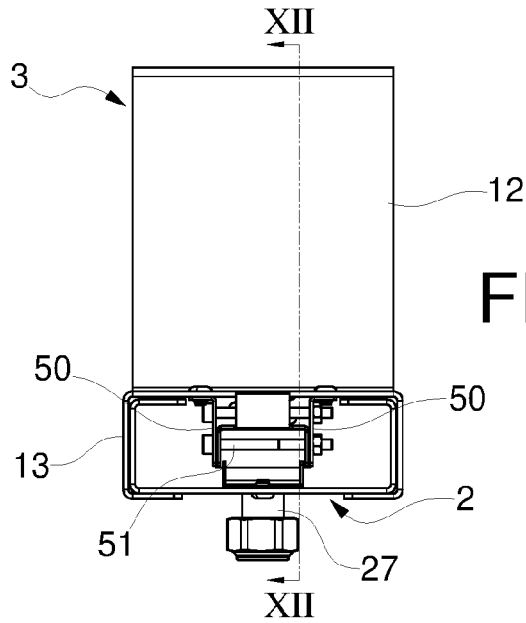

FIG. 11

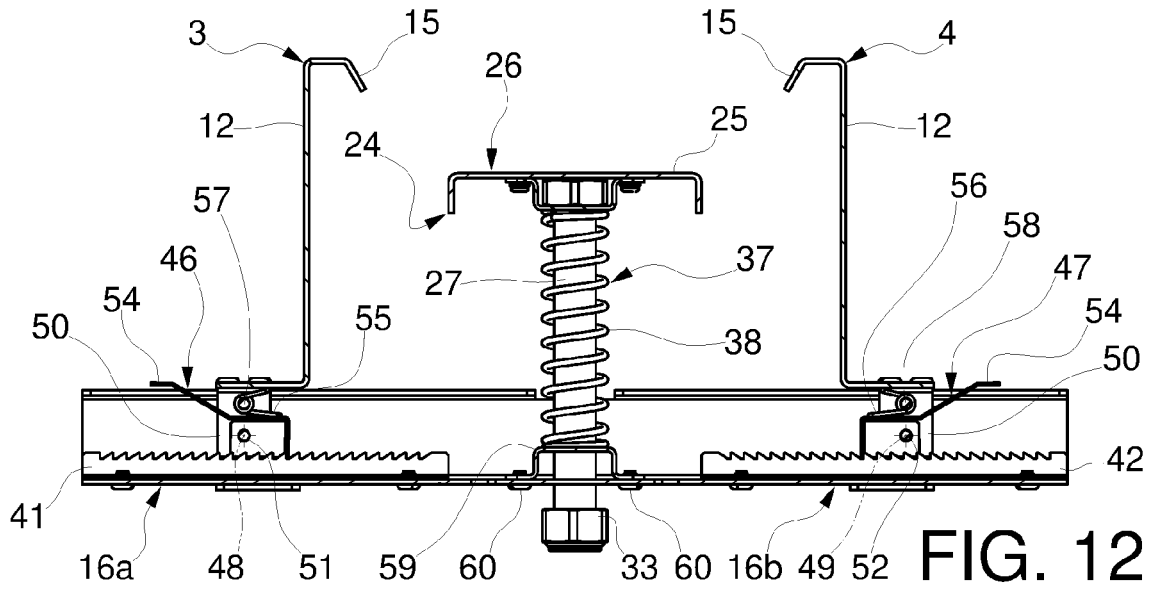

FIG. 12

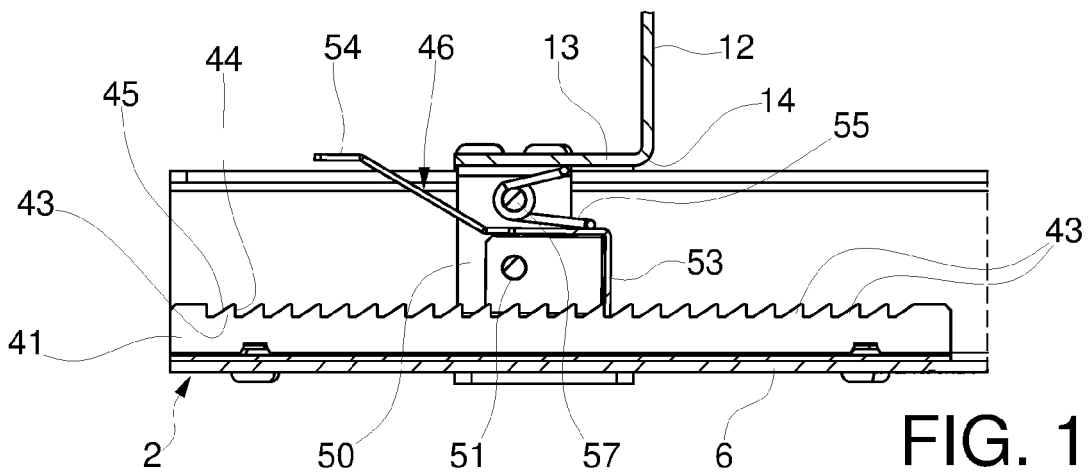

FIG. 13



EUROPEAN SEARCH REPORT

Application Number
EP 20 20 7652

5

10

15

20

25

30

35

40

45

50

55

DOCUMENTS CONSIDERED TO BE RELEVANT			
Category	Citation of document with indication, where appropriate, of relevant passages	Relevant to claim	CLASSIFICATION OF THE APPLICATION (IPC)
X A	IT FI20 100 244 A1 (RUUD LIGHTING EUROP S R L) 21 June 2012 (2012-06-21) * figures 4a-4c *	1-3 4-8,11, 12	INV. F21V21/02 F21V21/14 F21V21/34
X A	----- EP 0 801 257 A1 (ERICO INT CORP [US]) 15 October 1997 (1997-10-15) * figure 2 *	1-3,9,10 4-8,11, 12	
X	----- EP 0 801 181 A2 (ERICO INT CORP [US]) 15 October 1997 (1997-10-15) * figure 2 *	1	
			TECHNICAL FIELDS SEARCHED (IPC)
			F21V F21W H02G
The present search report has been drawn up for all claims			
Place of search The Hague		Date of completion of the search 9 March 2021	Examiner Kebemou, Augustin
CATEGORY OF CITED DOCUMENTS X : particularly relevant if taken alone Y : particularly relevant if combined with another document of the same category A : technological background O : non-written disclosure P : intermediate document		T : theory or principle underlying the invention E : earlier patent document, but published on, or after the filing date D : document cited in the application L : document cited for other reasons & : member of the same patent family, corresponding document	

1
EPO FORM 1503 03.82 (P04C01)

ANNEX TO THE EUROPEAN SEARCH REPORT
ON EUROPEAN PATENT APPLICATION NO.

EP 20 20 7652

5

This annex lists the patent family members relating to the patent documents cited in the above-mentioned European search report. The members are as contained in the European Patent Office EDP file on
The European Patent Office is in no way liable for these particulars which are merely given for the purpose of information.

09-03-2021

10

Patent document cited in search report	Publication date	Patent family member(s)	Publication date
IT FI20100244	A1	21-06-2012	-----
EP 0801257	A1	15-10-1997	-----
		AT 223009 T	15-09-2002
		CZ 292149 B6	13-08-2003
		DE 69714899 T2	16-01-2003
		EP 0801257 A1	15-10-1997
		ES 2183035 T3	16-03-2003
		HU 9700726 A2	30-03-1998
		PL 319396 A1	13-10-1997
		SK 45297 A3	14-01-1998
		US 6012691 A	11-01-2000
-----	-----	-----	-----
EP 0801181	A2	15-10-1997	-----
		AT 225444 T	15-10-2002
		DE 69715949 T2	12-06-2003
		EP 0801181 A2	15-10-1997
		US 5713157 A	03-02-1998
-----	-----	-----	-----

15

20

25

30

35

40

45

50

55

EPO FORM P0459

For more details about this annex : see Official Journal of the European Patent Office, No. 12/82