



(11) **EP 3 825 253 A1**

(12) **EUROPEAN PATENT APPLICATION**

(43) Date of publication:
26.05.2021 Bulletin 2021/21

(51) Int Cl.:
B65D 83/00 (2006.01) **B65D 5/76 (2006.01)**
B65D 25/52 (2006.01) **B65G 33/14 (2006.01)**

(21) Application number: **19210978.3**

(22) Date of filing: **22.11.2019**

(84) Designated Contracting States:
AL AT BE BG CH CY CZ DE DK EE ES FI FR GB GR HR HU IE IS IT LI LT LU LV MC MK MT NL NO PL PT RO RS SE SI SK SM TR
 Designated Extension States:
BA ME KH MA MD TN

(71) Applicant: **Henkel AG & Co. KGaA**
40589 Düsseldorf (DE)

(72) Inventor: **Ozkul, Omer**
Dubai (AE)

(54) **SYSTEM WITH OUTER PACKAGING FOR DETERGENTS AND DEVICE FOR WITHDRAWING THE DETERGENT**

(57) A system, comprising an outer packaging (2) for a free-flowing detergent or cleaning agent and a device (1) for withdrawing the free-flowing detergent or cleaning agent from the outer packaging (2), wherein the device (1) has an Archimedean screw (10) with a spiral (100) and a central shaft (101), and a retainer (11) accommodating the screw (10), wherein side walls (23) of the outer packaging (2) include at least one opening (20) for

detachably fastening the device (1) in the outer packaging (2) and/or for withdrawing the free-flowing detergent or cleaning agent, wherein, in the working position of the device (1) in the outer packaging (1), the free-flowing detergent or cleaning agent is extracted from the outer packaging (2) by rotating the screw (10), wherein a shaft part extends through the opening (20) for rotatably mounting the screw (10).

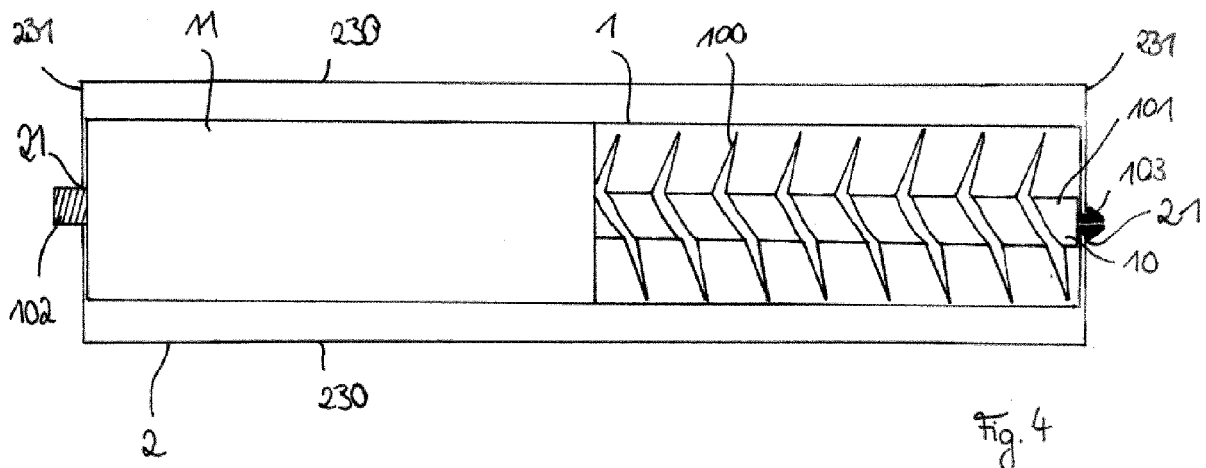

EP 3 825 253 A1

Description

[0001] The invention relates to a system comprising an outer packaging for a free-flowing detergent or cleaning agent and a device for withdrawing the free-flowing detergent or cleaning agent from the outer packaging.

[0002] Outer packagings for storing free-flowing detergent or cleaning agent as they are usually offered by retail traders commonly have large openings in the form of lids extending across the entire base area of the outer packaging.

[0003] Such a large opening is disadvantageous in that the high air humidity often prevalent in laundry rooms can easily enter the packaging, and the free-flowing detergent or cleaning agent thus tends to clump. Furthermore, exact dosing when pouring the detergent from the outer packaging is made difficult in the case of such outer packagings with very large openings, through which the detergent is withdrawn. There is a danger of too much detergent being metered out or even spilled. For this reason, measuring cups are frequently used in order to circumvent this problem; however, skin contact with the detergent, which may lead to irritations, cannot be avoided in this case.

[0004] It is therefore the object of the present invention to provide an outer packaging that is suitable for enabling manual dosing and, at the same time, for protecting the detergent from excessive air humidity and the negative effects on the detergent associated therewith.

[0005] This object is achieved with the subject matter of the independent patent claim.

[0006] Advantageous embodiments and developments are the subject matter of the dependent claims, the enclosed description and the Figures.

[0007] According to the invention, a system is provided, which comprises an outer packaging for a free-flowing detergent or cleaning agent and a device for withdrawing the free-flowing detergent or cleaning agent from the outer packaging.

[0008] The outer packaging according to the invention serves for storing free-flowing detergent or cleaning agent, or detergent in short; however, other free-flowing products may also be stored in the outer packaging. The outer packaging is preferably configured for accommodating 1 to 15 l, particularly preferably for accommodating 3 to 10 l. These are standard retail quantities for end consumers. However, the outer packaging may also be configured for accommodating greater quantities of detergent, e.g. for detergent quantities between 15 and 50 l. This type of outer packaging is mostly found with bulk purchasers, such as launderettes or laundries.

[0009] The outer packaging is preferably formed to be cuboid with end faces that, compared to the front and rear sides, have a narrower shape. Particularly with regard to transport and warehousing, a cuboid outer packaging offers advantages because it can be stacked in a space-saving manner.

[0010] The device includes an Archimedean screw

with a spiral and a central shaft, and a retainer accommodating the screw. Side walls of the outer packaging include at least one opening for detachably fastening the device in the outer packaging and/or for withdrawing the detergent. Using the Archimedean screw in the sense of the present invention, an axial displacement of the detergent in the direction of the opening of the outer packaging can be carried out by rotating the spiral. In this case, a shaft part extends through the opening for rotatably mounting the screw. Manually rotating the screw is possible by means of this shaft part. The shaft of the screw rotates, and together with it, the spiral non-rotatably connected thereto. The spiral mounted in the retainer conveys the detergent in the direction of the opening during the rotary movement. Clumps that may have formed are broken up again during this process, so that the opening does not clog up. In addition, exact dosing is possible.

[0011] According to an exemplary embodiment, the shaft part is formed integrally with the shaft of the Archimedean screw. It constitutes an end section of the shaft protruding from the outer packaging. The device can be rotated from the outside by means of this end section, whereby detergent can be extracted from the outer packaging.

[0012] It is also conceivable that a bolt is inserted through the opening from the outside and connected to the central shaft. In this case, the bolt constitutes the shaft part extending through the opening.

[0013] According to another exemplary embodiment, the end section has means for the non-rotatable connection to a handle, e.g. configured as a thread. After fastening the device in the outer packaging, the handle can thus be screwed on from the outside. Using the handle, the screw can be rotated manually and the detergent can thus be withdrawn.

[0014] According to another exemplary embodiment, the retainer is configured, at least in some regions, as a tube completely enclosing the screw. Preferably, this region is a half of the retainer facing towards the opening. The other half of the retainer encloses the screw in a substantially semi-circular shape on the side facing towards the bottom of the outer packaging. It is thus ensured that detergent can always trickle into the device from above, but the retainer at the same time provides the screw with sufficient support and, particularly in the case of a large filling quantity, reduces the pressure of the detergent on the screw, so that the rotation process is not affected. Preferably, the part of the retainer configured as a tube completely enclosing the screw extends over 25 to 75% of the total length of the retainer. The configuration in which the retainer, over 50% of its total length, is configured as a tube completely enclosing the screw is particularly preferred.

[0015] According to a proposal of the invention, the retainer, in the working position of the device, rests on a bottom of the outer packaging. Thus, the device is supported from below.

[0016] According to an embodiment of the invention, the screw is formed integrally. The screw may be produced as a single piece, for example by means of a 3D printing process. However, the screw may also have a multi-part design; for example, the central shaft and the spiral may be configured as individual constituent parts that can be assembled into an Archimedean screw.

[0017] According to another exemplary embodiment, the outer packaging consists of cardboard. Cardboard is an easily available, inexpensive and sustainable material which nevertheless has a sufficiently high stability for storing even larger quantities of detergent, as well as for transporting and warehousing. However, using plastic or reinforced paper as a starting material for the outer packaging is also conceivable.

[0018] It is provided in one exemplary embodiment that the opening is formed from a large semi-circle for withdrawal and a small semi-circle adjacent to the large semi-circle, for accommodating the device. With regard to its diameter, the large semi-circle for withdrawing the detergent in this case substantially corresponds to the diameter of the spiral, so that exact dosing can be ensured. The small semi-circle serves for accommodating the shaft part. The device is thus delimited and fixed with regard to its position.

[0019] According to another aspect of the invention, a tear line delimiting the opening is provided. This may be, for example, stamped or scored into the side wall of the outer packaging and outlines the region of the side wall that can be removed for producing the opening.

[0020] According to a proposal of the invention, the opening is closed prior to commissioning. In this way, detergent is prevented from leaking from the outer packaging in an undesirable manner during the transport of the outer packaging and when it is warehoused and presented in the shops. By pushing through the outer packaging in the region of the opening, the consumer is able to simply break out the closing piece along the tear line.

[0021] In one exemplary embodiment, it is provided that the opening is sealed by means of an adhesive seal prior to commissioning. The opening may already be integrated into the outer packaging at the factory and then resealed by means of an adhesive seal. As a result, the opening can be very easily opened by the consumer. The application safety of and ease of commissioning the outer packaging are increased as a result.

[0022] According to another exemplary embodiment, another accommodating portion for the device is provided in a side wall opposite to the side wall with the opening. As a result, the device can be additionally fixed so that it can be used without failure. Optionally, the accommodating portion may be provided as an opening penetrating the side wall, or also as an indentation in the material of the side wall into which the device is clamped.

[0023] Particularly preferably, the device is configured in such a way, regarding its total length, that it protrudes with one end section from the outer packaging to such an extent that a manual operation from the outside is

possible without any problems and that the spiral substantially extends over the entire length of the interior. However, configurations are also conceivable in which the spiral does not extend over the entire length of the interior of the outer packaging but only over a smaller part.

[0024] The device may be additionally fixed by means of one or more clips along the opening. The device is detachably fixed to the outer packaging by clips.

[0025] A proposal of the invention provides the use of a device comprising a screw and a retainer for withdrawing a free-flowing detergent or cleaning agent from the outer packaging.

[0026] The bottom of the outer packaging, which in the operational state of the outer packaging faces downwards and serves as the standing surface, can be opened. The bottom may be formed by several tabs, for example, but may also be formed integrally. If the outer packaging is turned so that the bottom is located at the upper end of the outer packaging, it can be opened without any danger of detergent leaking out inadvertently. The device may then be inserted into the outer packaging and fixed through the opened bottom. Then, it is closed again and the outer packaging is turned around, so that the bottom again forms the standing surface of the outer packaging. The device is then ready for operation and can be used for extracting detergent from the outer packaging.

[0027] When the outer packaging has been emptied completely, it may be recycled after the device has been removed again. The device may then be inserted into another outer packaging and reused.

[0028] The invention is explained in more detail with reference to the exemplary embodiments depicted in the drawing. In the Figures:

Figure 1 shows an exemplary embodiment of an Archimedean screw;

Figure 2 shows a device according to the invention, comprising the Archimedean screw according to Figure 1;

Figure 3 shows an exemplary embodiment of an outer packaging; and

Figure 4 shows a system consisting of the device according to the exemplary embodiment from Figure 2 and the outer packaging according to the exemplary embodiment from Figure 3.

[0029] Figure 1 depicts an Archimedean screw 10 according to an exemplary embodiment of the invention. The screw 10 comprises a spiral 100 and a central shaft 101. A shaft part of the central shaft 101 is configured as an end section 102. The end section 102 comprises a thread, to which a handle, for example, can be attached, by means of which the screw 10 can be manually rotated

in a simple manner. A clamp 103 is disposed on the opposite end of the central shaft 101. The screw 10 can be additionally fastened to an outer packaging by means of this clamp 103.

[0030] Figure 2 shows a device 1 according to the invention, which comprises the screw 10 according to Figure 1 and a retainer 11. The screw 10 is mounted in the retainer 11. In some regions, the retainer 11 is configured as a tube completely enclosing the screw 10. In addition, the retainer 11 is configured in some regions only as a half-tube, which surrounds the screw 10 only in the lower half facing towards the bottom. The end section 102 of the shaft 101 protrudes over the retainer 11 because it serves for fixing the device 1 in an outer packaging. The retainer 11 is configured in such a way that it accommodates the screw 10, making it possible in the process that the spiral 100 is able to rotate unimpededly.

[0031] Figure 3 shows an outer packaging 2 according to the invention. The outer packaging 2 is formed to be cuboid and with side walls 23, and has end faces 231 that, compared to a front or a rear side 230, have a narrower shape. One of these end faces 231 has an opening 20. An accommodating portion 21 is adjacent to the opening 20. The opening 20 and the accommodating portion 21 are each configured with a semi-circular shape and combine to form a contiguous through-hole. The diameter of the opening 20 is based on the diameter of the spiral 100 of the device 1 according to Figure 2, the diameter of the accommodating portion 21 is based on the diameter of the end section 102 of the device 1 according to Figure 2. Figure 3 depicts the outer packaging prior to commissioning. The opening 20 and the accommodating portion 21 are sealed by means of an adhesive seal 22. The adhesive seal 22 is applied in the factory after the packaging material has been removed, or tear lines incorporated, in the region of the opening 20 and the accommodating portion 21. If the outer packaging 2 is filled with detergent, the adhesive seal 22 prevents detergent from leaking out in this region.

[0032] Figure 4 shows the device 1 in the working position in the outer packaging 2 from above, as a section along the line IV-IV in Figure 3. The screw 10 is surrounded by the retainer 11 and mounted in the accommodating portions 21 in each case at the end faces 231 of the outer packaging 2. The end section 102 mounted in the accommodating portion 21 protrudes from the opening 20. On the opposite end face 231 of the outer packaging 2, the clamp 103 is also mounted in another accommodating portion 21. Due to the device 1 being fixed by the accommodating portions 21, the device 1 has sufficient support so as not to slip, because the shaft 101 is axially fixed on both sides in the outer packaging 2. With respect to its total length, the device 1 is longer than the front and rear sides 230 of the outer packaging 2 and, in the interior, also extends over the entire length of the front and rear sides 230. About 50% of the total length of the spiral 100 are surrounded by the retainer 11 as a tube completely enclosing the former, and about 50% as a half-tube that

only encloses the lower half of the spiral 100. It is thus ensured that a sufficient amount of detergent is always able to trickle down from above and that dosing can be ensured. In the region in which the retainer 11 completely encloses the screw 10, the pressure acting on the screw 10 from the detergent from above is reduced. Consequently, a manual rotation of the screw 10 is possible without excessive application of force.

10 List of Reference Numerals:

[0033]

1	Device
15 10	Screw
100	Spiral
101	Shaft
102	End section
11	Retainer
20 2	Outer packaging
20	Opening
21	Accommodating portion
22	Adhesive seal
23	Side wall
25 230	Front or rear side
231	End face
IV-IV	Line of cut

30 **Claims**

1. A system, comprising an outer packaging (2) for a free-flowing detergent or cleaning agent and a device (1) for withdrawing the free-flowing detergent or cleaning agent from the outer packaging (2), wherein the device (1) has an Archimedean screw (10) with a spiral (100) and a central shaft (101), and a retainer (11) accommodating the screw (100), wherein side walls (23) of the outer packaging (2) include at least one opening (20) for detachably fastening the device (1) in the outer packaging (2) and/or for withdrawing the free-flowing detergent or cleaning agent, wherein, in the working position of the device (1) in the outer packaging (1), the free-flowing detergent or cleaning agent is extracted from the outer packaging (2) by rotating the screw (10), wherein a shaft part extends through the opening (20) for rotatably mounting the screw (10).
2. The system according to claim 1, **characterized in that** the shaft part is formed integrally with the shaft of the Archimedean screw (10) and constitutes an end section (102) of the shaft protruding from the outer packaging (2).
3. The system according to claim 2, **characterized in that** the end section (102) includes means for the non-rotatable connection to a handle.

4. The system according to any one of the claims 1 to 3, **characterized in that** the retainer (11) is configured, at least in some regions, as a tube completely enclosing the screw (10). 5
5. The system according to any one of the claims 1 to 4, **characterized in that** the retainer (11), in the working position of the device (1), rests on a bottom of the outer packaging (2). 10
6. The system according to any one of the claims 1 to 5, **characterized in that** the screw (10) is formed of a single piece.
7. The system according to any one of the claims 1 to 6, **characterized in that** the screw outer packaging (2) consists of cardboard. 15
8. The system according to any one of the claims 1 to 7, **characterized in that** the opening (20) is formed from a large semi-circle for withdrawal and a small semi-circle adjacent to the large semi-circle, as an accommodating portion (21) for the device (1). 20
9. The system according to any one of the claims 1 to 8, **characterized in that** a tear line delimiting the opening (20) is provided. 25
10. The system according to any one of the claims 1 to 9, **characterized in that** the opening (20) is closed prior to commissioning. 30
11. The system according to claim 10, **characterized in that** the opening (20) is sealed by means of an adhesive seal (22) prior to commissioning. 35
12. The system according to any one of the claims 1 to 11, **characterized in that** another accommodating portion (23) for the device (1) is provided in a side wall (23) opposite to the side wall (23) with the opening (20). 40
13. Use of a device (1) comprising a screw (10) and a retainer (11) for withdrawing a free-flowing detergent or cleaning agent in a system according to any one of the claims 1 to 12. 45

50

55

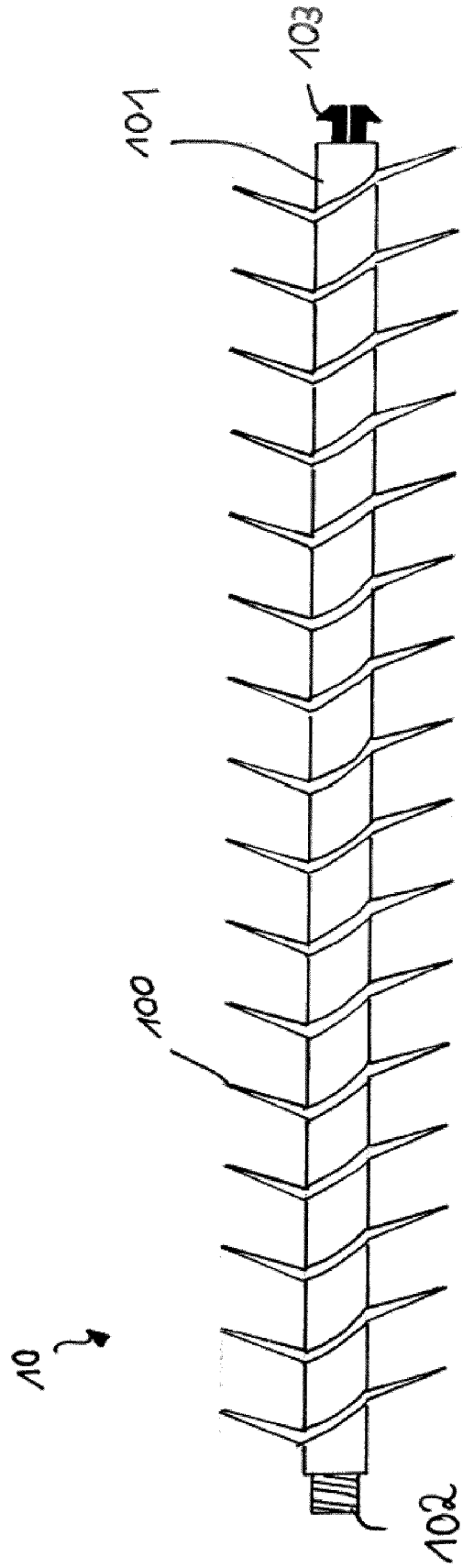

Fig. 1

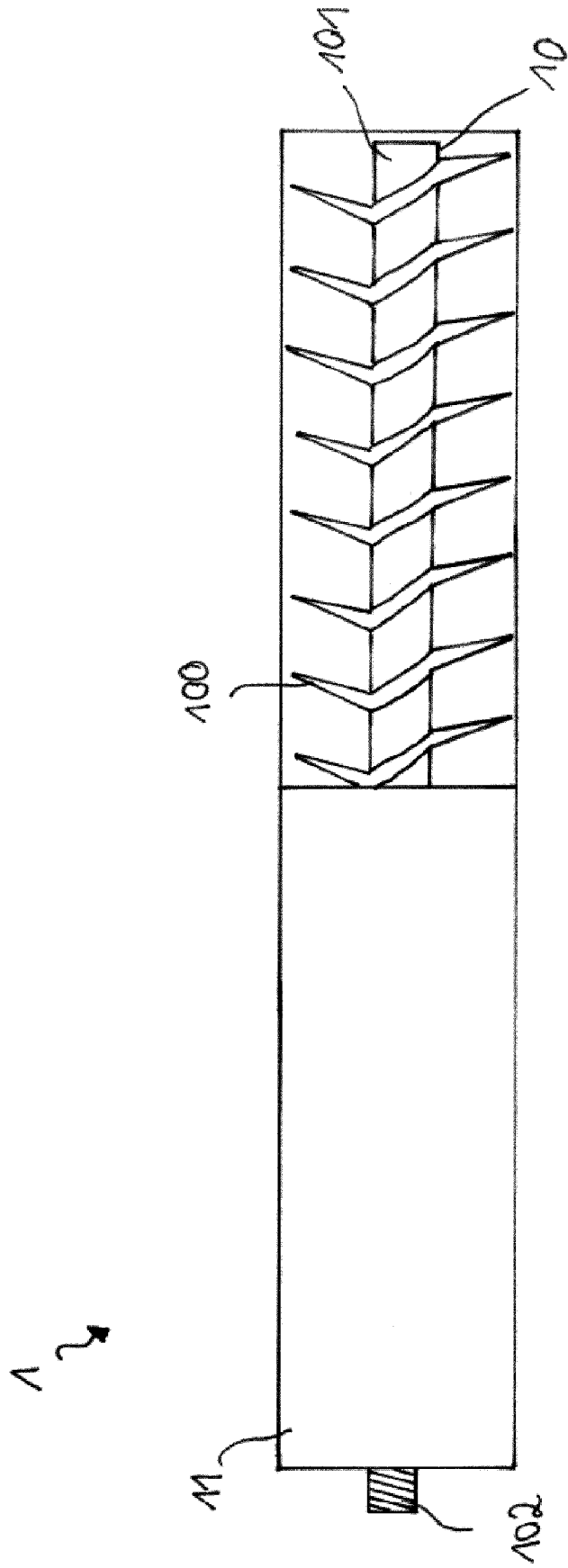

Fig. 2

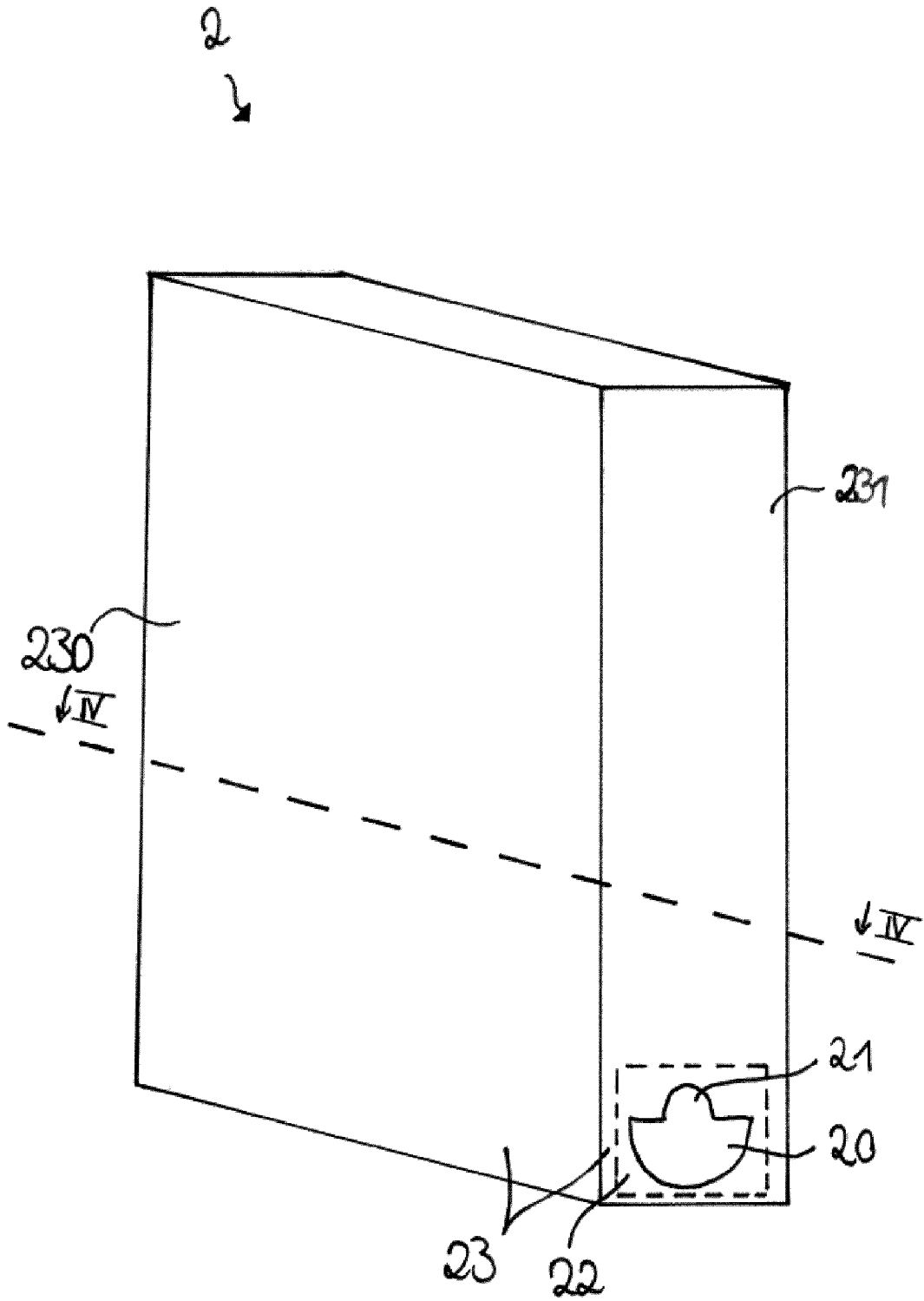

Fig. 3

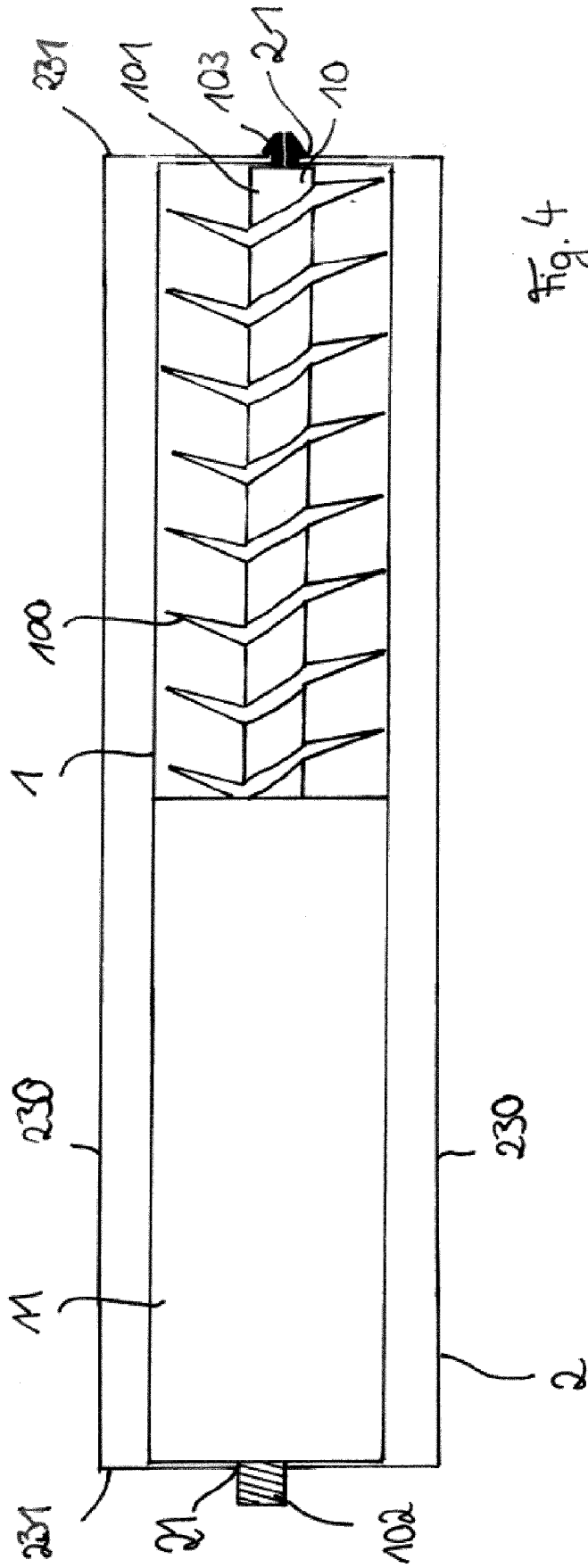

Fig. 4



EUROPEAN SEARCH REPORT

Application Number
EP 19 21 0978

5

10

15

20

25

30

35

40

45

50

55

DOCUMENTS CONSIDERED TO BE RELEVANT			
Category	Citation of document with indication, where appropriate, of relevant passages	Relevant to claim	CLASSIFICATION OF THE APPLICATION (IPC)
X	DE 10 2009 060598 A1 (GIEMA GMBH [DE]) 30 June 2011 (2011-06-30)	1-7,12,13	INV. B65D83/00 B65D5/76 B65D25/52 B65G33/14
Y	* paragraph [0020] - paragraph [0028]; figures 1-2 *	8-11	
Y	US 5 137 175 A (KOWALSKI HENRY C [US] ET AL) 11 August 1992 (1992-08-11) * column 16, lines 36-48; figure 19 *	8-11	
X	CN 2 194 877 Y (LIU LIMENG [CN]) 19 April 1995 (1995-04-19) * abstract; figures 1-2 *	1-7,13	
X	WO 02/090223 A2 (FORSBERG GOERAN [SE]) 14 November 2002 (2002-11-14) * page 4, lines 5-32; figures 1-23 *	1-6,13	
			TECHNICAL FIELDS SEARCHED (IPC)
			B65D B65G A47F G01F
The present search report has been drawn up for all claims			
Place of search Munich		Date of completion of the search 28 April 2020	Examiner Grondin, David
CATEGORY OF CITED DOCUMENTS X : particularly relevant if taken alone Y : particularly relevant if combined with another document of the same category A : technological background O : non-written disclosure P : intermediate document T : theory or principle underlying the invention E : earlier patent document, but published on, or after the filing date D : document cited in the application L : document cited for other reasons & : member of the same patent family, corresponding document			

EPO FORM 1503 03.02 (P04C01)

ANNEX TO THE EUROPEAN SEARCH REPORT
ON EUROPEAN PATENT APPLICATION NO.

EP 19 21 0978

5 This annex lists the patent family members relating to the patent documents cited in the above-mentioned European search report.
The members are as contained in the European Patent Office EDP file on
The European Patent Office is in no way liable for these particulars which are merely given for the purpose of information.

28-04-2020

Patent document cited in search report	Publication date	Patent family member(s)	Publication date
DE 102009060598 A1	30-06-2011	NONE	
US 5137175 A	11-08-1992	NONE	
CN 2194877 Y	19-04-1995	NONE	
WO 02090223 A2	14-11-2002	AT 415368 T	15-12-2008
		BR 0209139 A	08-06-2004
		CA 2443584 A1	14-11-2002
		CN 1524056 A	25-08-2004
		CN 1966368 A	23-05-2007
		DK 1385763 T3	16-02-2009
		EP 1385763 A2	04-02-2004
		ES 2318005 T3	01-05-2009
		JP 4653937 B2	16-03-2011
		JP 2004524248 A	12-08-2004
		KR 20040012801 A	11-02-2004
		KR 20090130095 A	17-12-2009
		NZ 528477 A	30-07-2004
		PT 1385763 E	17-02-2009
		RU 2299168 C2	20-05-2007
		WO 02090223 A2	14-11-2002
		ZA 200307639 B	01-07-2004