



(11) **EP 3 858 260 A1**

(12) **EUROPEAN PATENT APPLICATION**

(43) Date of publication:
04.08.2021 Bulletin 2021/31

(51) Int Cl.:
A61B 17/072 (2006.01) **A61B 17/29 (2006.01)**
A61B 17/00 (2006.01) **A61B 90/00 (2016.01)**

(21) Application number: **21154283.2**

(22) Date of filing: **29.01.2021**

(84) Designated Contracting States:
AL AT BE BG CH CY CZ DE DK EE ES FI FR GB GR HR HU IE IS IT LI LT LU LV MC MK MT NL NO PL PT RO RS SE SI SK SM TR
 Designated Extension States:
BA ME
 Designated Validation States:
KH MA MD TN

(71) Applicant: **Covidien LP**
Mansfield, MA 02048 (US)

(72) Inventors:
 • **CHAVAN, Varad V.**
416012 Kolhapur (IN)
 • **FERNANDES, Roanit A.**
500026 Hyderabad (IN)

(30) Priority: **31.01.2020 US 202062968222 P**
17.11.2020 US 202017099920

(74) Representative: **Maschio, Antonio**
Maschio & Soames IP Limited
30 Carlton Crescent
Southampton SO15 2EW (GB)

(54) **SURGICAL STAPLING DEVICE WITH LOCKOUT**

(57) A surgical stapling device includes a tool assembly having an anvil assembly (36), a cartridge assembly (34), and a lockout member (46) supported on the anvil assembly (36). The anvil assembly (36) includes an anvil

cover defining a cutout (42a). The lockout member (46) is supported on the tool assembly to prevent firing of the stapling device when an actuation sled (130) is not present in the cartridge assembly (34).

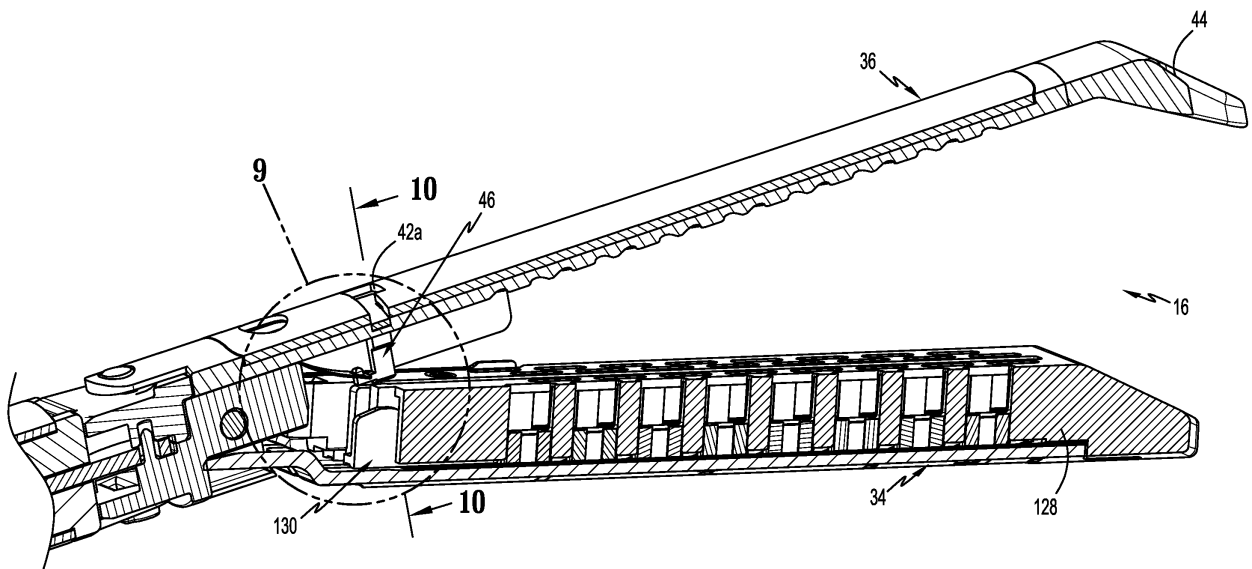

FIG. 8

EP 3 858 260 A1

Description

CROSS-REFERENCE TO RELATED APPLICATION

[0001] This application claims the benefit of and priority to U.S. Provisional Patent Application No. 62/968,222 filed January 31, 2020, the entire disclosure of which is incorporated by reference herein.

FIELD

[0002] This disclosure is directed to stapling devices and, more particularly, to surgical stapling devices that have a tool assembly including a lockout to prevent firing of the stapling device when an actuation sled is not present in the tool assembly.

BACKGROUND

[0003] Surgical stapling devices for simultaneously stapling and cutting tissue are known in the art and are available in a variety of open and endoscopic configurations including linear, circular, and curved. Typically, linear surgical stapling devices that are configured for endoscopic use include a staple cartridge having a knife bar for cutting tissue and an actuation sled that is movable through the staple cartridge to eject staples from the staple cartridge prior to cutting the tissue. In some devices, the actuation sled is engaged and advanced through the staple cartridge by the knife bar.

[0004] When an actuation sled is not present in the tool assembly, advancement of the knife bar through the staple cartridge of the stapling device cuts body tissue but does not affect stapling of the body tissue. This may have serious consequences for the patient. A continuing need exists in the art for a mechanism that can prevent firing of a surgical stapling device that does not include an actuation sled.

SUMMARY

[0005] One aspect of this disclosure is directed to a surgical stapling device including a cartridge assembly, a drive assembly, and an anvil assembly. The cartridge assembly includes a staple cartridge and an actuation sled positioned within the staple cartridge. The actuation sled is movable from a retracted position to an advanced position to eject staples from the staple cartridge. The drive assembly includes a flexible drive beam and a working member including a vertical strut, an upper beam, and a lower beam. The drive assembly is movable from a retracted position to an advanced position to move the actuation sled from its retracted position to its advanced position. The anvil assembly is pivotally secured to the cartridge assembly and is movable in relation to the cartridge assembly between open and clamped positions. The anvil assembly includes an anvil body, an anvil cover, and a lockout member. The anvil body includes an anvil

member having an inner surface defining a plurality of staple deforming pockets, an outer surface defining a longitudinal groove, a central knife slot extending between the inner and outer surfaces, and a through bore extending between the inner and outer surfaces. The anvil cover defines a cutout and is secured to the anvil body to define a longitudinal channel within the anvil assembly. The longitudinal channel is positioned to receive the upper beam of the working member of the drive assembly. The lockout member has a horizontal portion and a vertical portion and is movable from a first position in which the horizontal portion of the lockout member is positioned within the longitudinal channel of the anvil assembly to obstruct distal movement of the upper beam of the working member within the anvil assembly to a second position in which the horizontal portion of the lockout member is positioned within the cutout of the anvil cover of the anvil assembly to allow distal movement of the upper beam of the working member within the anvil assembly.

[0006] In aspects of the disclosure, a biasing member is provided to urge the lockout member towards the first position.

[0007] In some aspects of the disclosure, the biasing member is a leaf spring.

[0008] In certain aspects of the disclosure, the vertical portion of the lockout member is positioned to engage the actuation sled when the actuation sled is in its retracted position.

[0009] In aspects of the disclosure, engagement between the vertical portion of the lockout member and the actuation sled moves the lockout member from the first position to the second position as the anvil and the cartridge assemblies are moved to the clamped position.

[0010] In some aspects of the disclosure, the horizontal portion of the lockout member includes a tapered distal surface and a proximal stop surface.

[0011] In certain aspects of the disclosure, the vertical portion of the lockout member includes a spring mount and the biasing member is secured to the spring mount.

[0012] In aspects of the disclosure, a dissector tip having a thickness that decreases in the distal direction is supported on the anvil body.

[0013] In some aspects of the disclosure, the stapling device includes an elongate body having a distal portion, and the cartridge assembly and the anvil assembly are supported on the distal portion of the elongate body.

[0014] In certain aspects of the disclosure, the cartridge assembly, the anvil assembly, and the drive assembly form a reload assembly that is removable from the elongate body.

[0015] In aspects of the disclosure, the stapling device includes a handle assembly and the elongate body extends distally from the handle assembly.

[0016] Another aspect of this disclosure is directed to a tool assembly that includes a cartridge assembly and an anvil assembly. The cartridge assembly includes a staple cartridge and an actuation sled positioned within the staple cartridge. The actuation sled is movable from

a retracted position to an advanced position to eject staples from the staple cartridge. The anvil assembly is pivotally secured to the cartridge assembly and is movable in relation to the cartridge assembly between open and clamped positions. The anvil assembly includes an anvil body, an anvil cover, and a lockout member. The anvil body includes an anvil member having an inner surface defining a plurality of staple deforming pockets, an outer surface defining a longitudinal groove, a central knife slot extending between the inner and outer surfaces, and a through bore extending between the inner and outer surfaces. The anvil cover defines a cutout and is secured to the anvil body to define a longitudinal channel within the anvil assembly. The lockout member has a horizontal portion and a vertical portion and is movable from a first position in which the horizontal portion of the lockout member is positioned within the longitudinal channel of the anvil assembly to a second position in which the horizontal portion of the lockout member is positioned within the cutout of the anvil cover of the anvil assembly.

[0017] Yet another aspect of this disclosure is directed to a surgical stapling device including an elongate body, a drive assembly, and a tool assembly. The elongate body extends distally from the handle assembly. The drive assembly includes a flexible drive beam and a working member that includes a vertical strut, an upper beam, and a lower beam. The drive assembly is movable from a retracted position to an advanced position to move the actuation sled from its retracted position to its advanced position. The tool assembly includes a cartridge assembly and an anvil assembly. The cartridge assembly includes a staple cartridge and an actuation sled positioned within the staple cartridge that is movable from a retracted position to an advanced position to eject staples from the staple cartridge. The anvil assembly is pivotally secured to the cartridge assembly such that the tool assembly is movable in relation to the cartridge assembly between open and clamped positions. The anvil assembly includes an anvil body, an anvil cover, and a lockout member. The anvil body includes an anvil member having an inner surface defining a plurality of staple deforming pockets, an outer surface defining a longitudinal groove, a central knife slot extending between the inner and outer surfaces, and a through bore extending between the inner and outer surfaces. The anvil cover defines a cutout and is secured to the anvil body to define a longitudinal channel within the anvil assembly. The longitudinal channel is positioned to receive the upper beam of the working member of the drive assembly. The lockout member has a horizontal portion and a vertical portion and is movable from a first position in which the horizontal portion of the lockout member is positioned within the longitudinal channel of the anvil assembly to obstruct distal movement of the upper beam of the working member within the anvil assembly to a second position in which the horizontal portion of the lockout member is positioned within the cutout of the anvil cover of the anvil assembly to allow distal movement of the upper beam of the working mem-

ber within the anvil assembly. The tool assembly also includes a biasing member positioned to urge the lockout member towards the first position.

[0018] Other features of the disclosure will be appreciated from the following description.

BRIEF DESCRIPTION OF THE DRAWINGS

[0019] Various aspects of the disclosed surgical stapling device are described herein below with reference to the drawings, wherein:

FIG. 1 is a side perspective view of a surgical stapling device including tool assembly having exemplary aspects of the disclosure;

FIG. 2 is a side perspective view of a reload assembly of the surgical stapling device shown in FIG. 1;

FIG. 3 is an exploded view of the anvil assembly and a drive assembly of the reload assembly shown in FIG. 2;

FIG. 4 is a bottom perspective view of an anvil assembly of the reload assembly shown in FIG. 2;

FIG. 5 is an enlarged view of the indicated area of detail shown in FIG. 2;

FIG. 6 is a cross-sectional view taken along section line 5-5 of FIG. 4;

FIG. 7 is an enlarged view of the indicated area of detail shown in FIG. 6;

FIG. 8 is a cross-sectional view taken along section line 8-8 of FIG. 2;

FIG. 9 is an enlarged view of the indicated area of detail shown in FIG. 8;

FIG. 10 is a cross-sectional view taken along section line 10-10 of FIG. 8;

FIG. 11 is a cross-sectional view taken along section line 8-8 of FIG. 1 with the tool assembly moved to a clamped position;

FIG. 12 is an enlarged view of the indicated area of detail shown in FIG. 11;

FIG. 13 is a cross-sectional view taken along section line 13-13 of FIG. 12;

FIG. 14 is a cross-sectional view of the tool assembly including an actuation sled taken through the drive member, the lockout member, and the actuation sled during firing of the tool assembly with the drive member engaged with the lockout member;

FIG. 15 is a cross-sectional view of the tool assembly shown in FIG. 14 during firing of the tool assembly with the drive member positioned distally of the lockout member;

FIG. 16 is a cross-sectional view of the tool assembly including an actuation sled taken through the drive member, the lockout member, and the actuation sled after firing of the tool assembly with the drive member reengaging with the lockout member;

FIG. 17 is a cross-sectional view of the tool assembly including an actuation sled taken through the drive member, the lockout member, and the actuation sled

during after firing of the tool assembly with the drive member reengaged with the lockout member.

FIG. 18 is an enlarged cross-sectional view taken through the lockout member of the tool assembly in which no actuation sled is present in the clamped position;

FIG. 19 is a cross-sectional view taken along section line 15-15 of FIG. 14; and

FIG. 20 is a cross-sectional view taken along section line 16-16 of FIG. 15.

DETAILED DESCRIPTION

[0020] The disclosed surgical stapling device including exemplary aspects of the disclosed tool assembly will now be described in detail with reference to the drawings in which like reference numerals designate identical or corresponding elements in each of the several views. However, it is to be understood that the aspects of the disclosure included herein are merely exemplary of the disclosure and may be embodied in various forms. Well-known functions or constructions are not described in detail to avoid obscuring the disclosure in unnecessary detail. Therefore, specific structural and functional details disclosed herein are not to be interpreted as limiting, but merely as a basis for the claims and as a representative basis for teaching one skilled in the art to variously employ the disclosure in virtually any appropriately detailed structure. In addition, directional terms such as front, rear, upper, lower, top, bottom, distal, proximal, and similar terms are used to assist in understanding the description and are not intended to limit the disclosure. As used herein, the terms "parallel", "perpendicular", and "aligned" are understood to include relative configurations that are substantially parallel, substantially perpendicular, and substantially aligned, i.e., up to about + or - 10 degrees from true parallel, true perpendicular, true alignment.

[0021] FIG. 1 illustrates a surgical stapling device shown generally as stapling device 10 that includes a handle assembly 12, an elongate body or adapter 14, and a tool assembly 16. As illustrated, the handle assembly 12 is manually actuated and includes a stationary handgrip 18, a firing trigger 20, a rotation knob 22, retraction knobs 24, and an articulation lever 26. The firing trigger 20 is operable to actuate various functions of the tool assembly 16 via the elongate body 14 including approximation, stapling, and cutting. In certain aspects of the disclosure, the tool assembly 16 forms part of a staple reload 30 (FIG. 3) includes a proximal body portion 32 that supports the tool assembly 16 and has a proximal end 32a that is adapted to be releasably coupled to the elongate body 14. Alternately, the tool assembly 16 can be coupled directly to the elongate body 14.

[0022] Although the stapling device 10 is illustrated as a manually actuated stapling device, it is envisioned that the aspects of this disclosure are also suitable for use with powered surgical stapling devices including roboti-

cally controlled stapling devices. For a more detailed description of internal components and operation of the various aspects of the stapling device 10, see U.S. Patent No. 9,055,943 (the '943 Patent) which discloses a surgical stapling device including a powered handle assembly and U.S. Patent No. 6,241,139 (the '139' Patent) which discloses a surgical stapling device including manually actuated handle assembly.

[0023] FIG. 2 illustrates the staple reload 30, which as described above includes the proximal body portion 32 and the tool assembly 16. The tool assembly 16 defines a longitudinal axis "X" (FIG. 2) and includes a cartridge assembly 34 and an anvil assembly 36. The cartridge assembly 34 and the anvil assembly 36 are coupled together such that the tool assembly 16 can pivot between an open position (FIG. 8) and a clamped position (FIG. 11). For a detailed description of the components of a suitable cartridge assembly 34, see, e.g., the '139 and '943 Patents.

[0024] FIGS. 3-6 illustrate the anvil assembly 36, which includes an anvil body 40, an anvil cover 42, a dissector tip 44, and a lockout member 46. The dissector tip 44 has a thickness that decreases in the distal direction to facilitate separation of target tissue from tissue adhered to the target tissue during a surgical procedure. The anvil body 40 includes a pair of wings 56 that define openings 58. The openings 58 receive a pivot member 60 (FIG. 2) to pivotably couple the anvil assembly 36 to the cartridge assembly 34 to facilitate movement of the tool assembly 16 between the open and clamped positions. The anvil member 52 includes an inner surface 64 that defines a plurality of rows of staple deforming pockets 66 (FIG. 4) and a central knife slot 68. In certain aspects of the disclosure, two rows of staple deforming pockets 66 are positioned on each side of the central knife slot 68. However, it is envisioned that the staple deforming pockets 66 may be provided on the inner surface 64 of the anvil member 52 in a variety of different arrays which may include one or more rows of staple deforming pockets 66 on each side of the central knife slot 68.

[0025] The anvil body 40 also includes an outer surface 70 (FIG. 6) that defines a longitudinal groove 72. The central knife slot 68 communicates with the groove 72 and extends along the longitudinal axis "X" of the tool assembly 16 towards the distal end of the groove 72. The anvil body 40 defines a through bore 76 that extends from within the groove 72 through the anvil body 40 and opens onto the inner surface 64 of the anvil member 52. The anvil body 40 includes a cam surface 80 (FIG. 3) formed in a proximal end of the groove 72.

[0026] FIG. 3 illustrates the drive assembly 100 which is known in the surgical arts and is described herein to the extent necessary to describe the operation of the stapling device 10. The drive assembly 100 includes a flexible drive beam 84 and a working member 86. The working member 86 includes a vertical strut 88, an upper beam 90, and a lower beam 92. The vertical strut 88 includes a knife 88a. The upper beam 90 is received in the longi-

tudinal groove 72 formed in the outer surface 70 of the anvil body 40 and the lower beam 92 is received on an outer surface 34a (FIG. 11) of the cartridge assembly 34. The vertical strut 88 extends from the upper beam 90 to the lower beam 92 through the central knife slot 68 of the anvil body 40 and through a knife slot (not shown) in the cartridge assembly 34. The drive assembly 100 is movable through the tool assembly 16 from a retracted position to an advanced position to move the tool assembly 16 from the open position to the clamped position to fire staples and to cut or transect tissue.

[0027] The anvil cover 42 is received on the outer surface 70 of the anvil body 40 and encloses the groove 72 to define a channel 82 (FIG. 6) within the anvil assembly 36. The anvil cover 42 defines a cutout 42a that is aligned with the through bore 76 formed in the anvil body 40. The anvil cover 42 confines the upper beam 90 (FIG. 3) of the drive assembly 100 of the stapling device 10 within the groove 72. The through bore 76 and the cutout 42a are positioned within the proximal end of the groove 72 in the anvil body 40 distally of the cam surface 80 and receive the lockout member 46 as described in further detail below. The lockout member 46 is positioned distally of the upper beam 90 of the drive assembly 100 within the channel 82 when the drive assembly 100 is in its retracted position.

[0028] FIGS. 6 and 7 illustrate the lockout member 46, which includes a body 110 having a substantially vertical portion 112 and a substantially horizontal portion 114. The horizontal portion 114 is received within the channel 82 of the anvil assembly 36 and the vertical portion extends through the through bore 76 in the anvil body 40. The horizontal portion 114 includes a shoulder 116 and a tapered distal surface 118. In certain aspects of the disclosure, the shape of the horizontal portion 114 corresponds to the shape of the cutout 42a. The vertical portion 112 of the lockout member 46 includes a spring mount 120.

[0029] The vertical portion 112 of the lockout member 46 is received within the through bore 76 of the anvil body 40 and is moveable between a first position in which the horizontal portion 114 of the lockout member 46 is positioned within the channel 82 of the anvil assembly 36 and a second position in which the horizontal portion 114 of the lockout member 46 is received in the cutout 42a of the anvil cover 42. A biasing member, e.g., a leaf spring 126 (FIG. 3), is provided to urge the lockout member 46 towards the first position. In the first position, the lockout member 46 prevents advancement of the upper beam 90 of the working member 86 within the channel 82 to prevent firing of the stapling device 10 (FIG. 1).

[0030] FIG. 8 illustrates the cartridge assembly 34 which includes a staple cartridge 128 and an actuation sled 130 (FIG. 8) that is positioned distally of the working member 86 (FIG. 12) of the drive assembly 100. When the working member 86 of the drive assembly 100 is driven through the cartridge assembly 34, the actuation sled 130 is engaged and driven by the working member 86

through the staple cartridge 128 from a retracted position to an advanced position to eject staples (not shown) from the staple cartridge 128. The actuation sled 130 is positioned distally of the knife 88a of the drive assembly 100 to staple or suture tissue before the tissue is cut by the knife 88a. When an actuation sled 130 is not included in the cartridge assembly 34, staples are not ejected from the cartridge assembly 34 and the tissue cut by the knife 88a is not sutured. The disclosed lockout member 46 prevents this from occurring as described below.

[0031] FIGS. 8-10 illustrate the tool assembly 16 of the stapling device 10 (FIG. 1) in the open position. In the open position, the working member 86 (FIG. 10) of the drive assembly 100 is in its retracted position positioned proximally of the lockout member 46 and the lockout member 46 is urged to the first position by the leaf spring 126. The vertical portion 112 of the lockout member 46 is aligned with but spaced from the actuation sled 130.

[0032] FIGS. 11-13 illustrate the tool assembly 16 including an actuation sled 130 as the tool assembly 16 is clamped. When the drive assembly 100 is advanced from its retracted position in the direction indicated by arrow "A" in FIG. 11, the upper beam 90 of the working member 86 engages and moves over the cam surface 80 (FIG. 3) of the anvil body 40 of the anvil assembly 36 and the lower beam 92 of the working member 86 engages a cam surface 140 of the cartridge assembly 34 of the tool assembly 16. When this occurs, the cartridge assembly 34 pivots in the direction indicated by arrow "B" in FIG. 11 towards the anvil assembly 36 such that the tool assembly 16 moves from the open position to the clamped position. As the cartridge assembly 34 pivots towards the anvil assembly 36, the vertical portion 112 of the lockout member 46 which is aligned with the actuation sled 130 engages the actuation sled 130 to move the lockout member 46 in the direction of arrows "C" in FIGS. 12 and 13 from its first position to its second position against the bias of the leaf spring 126 (FIG. 12). When the lockout member 46 moves from the first position to the second position, the horizontal portion 114 of the lockout member 46 moves from a position within the channel 82 (FIG. 13) of the anvil assembly 36 to a position located within the cutout 42a of the cover 42 of the anvil assembly 36. In this position, the upper beam 90 of the working member 86 can pass under the horizontal portion 114 of the lockout member 46 to fire the stapling device 10 (FIG. 1).

[0033] FIGS. 14 and 15 illustrate the tool assembly 16 as the drive assembly 100 is advanced in the direction of arrows "D" to fire staples. As the actuation sled 130 moves distally in the direction of arrows "D", the actuation sled 130 is moved from beneath the vertical portion 112 (FIG. 13) of the lockout member 46. As this occurs, the upper beam 90 of the working member 86 moves beneath the horizontal portion 114 of the lockout member 46 to retain the lockout member 46 in the second position (FIG. 14) and allow the working member 86 of the drive assembly 100 to pass distally of the lockout member 46 to fire staples from the cartridge assembly 34 and cut tissue

clamped between the cartridge assembly 34 and the anvil assembly 36. When the upper beam 90 of the working member 86 of the drive assembly 100 passes distally beyond the horizontal portion 114 of the lockout member 46, the leaf spring 126 (FIG. 12) urges the lockout member 46 in the direction of arrow "E" in FIG. 15 back to the first position (FIG. 15).

[0034] FIGS. 16 and 17 illustrate the tool assembly 16 after the stapling device 10 (FIG. 1) is fired as the working member 86 is moved from its advanced position back to its retracted position in the direction indicated by arrows "F". As the upper beam 90 moves through the channel 82 in the anvil assembly 36, the upper beam 90 engages the tapered distal surface 118 (FIG. 16) of the horizontal portion 114 of the lockout member 46 to urge the lockout member 46 against the bias of the leaf spring 126 (FIG. 12) in the direction of arrow "G" in FIG. 17 back to the second position. In the second position of the lockout member 46, the horizontal portion 114 of the lockout member 46 is positioned within the cutout 42a of the anvil assembly 36 and the upper beam 90 is able to pass through the channel 82 of the anvil assembly 36 to a position distally of the lockout member 46. When the upper beam 90 moves to a position proximally of the lockout member 46, the lockout member 46 is urged back to the first position with the horizontal portion 114 of the lockout member 46 positioned within the channel 82 of the anvil assembly 36. It is noted that the actuation sled 130 is only in abutting relation with the actuation sled 130 and is not retracted with the drive assembly 100 as the drive assembly 100 returns to its retracted position.

[0035] FIGS. 18-20 illustrate the tool assembly 16 including a cartridge assembly 34 that does not have an actuation sled 130 (FIG. 12) in a clamped position. As illustrated, when the tool assembly 16 is moved to the clamped position (in the same manner as described above in reference to FIGS. 11-13), the vertical portion 112 of the lockout member 46 is moved into the cartridge assembly 34. However, since the actuation sled 130 is not present in the cartridge assembly, the vertical portion 112 of the lockout member 46 does not engage the actuation sled 130 and the lockout member 46 remains in the first position. As illustrated in FIG. 20, in the first position, the horizontal portion 114 of the lockout member 46 is positioned within the channel 82 of the anvil assembly 36 to obstruct advancement of the upper beam 90 of the working member 86 of the drive assembly 100. In certain aspects of the disclosure, the proximal side of the horizontal portion 114 of the lockout member 46 includes a vertical stop surface 150 that engages the upper beam 90 to prevent advancement of the working member 46 of the drive assembly 100. The lockout member 100 prevents firing of the stapling device 10 when the tool assembly 16 does not include an actuation sled 130.

[0036] Persons skilled in the art will understand that the devices and methods specifically described herein and illustrated in the accompanying drawings are non-limiting exemplary aspects of the disclosure. It is envi-

sioned that the elements and features illustrated or described in connection with one exemplary embodiment may be combined with the elements and features of another without departing from the scope of the disclosure.

5 As well, one skilled in the art will appreciate further features and advantages of the disclosure based on the above-described embodiments. Accordingly, the disclosure is not to be limited by what has been particularly shown and described, except as indicated by the appended claims.

[0037] The invention may be described by reference to the following numbered paragraphs:-

1. A surgical stapling device comprising:

15 a cartridge assembly including a staple cartridge and an actuation sled positioned within the staple cartridge, the actuation sled movable from a retracted position to an advanced position to eject staples from the staple cartridge;

20 a drive assembly including a flexible drive beam and a working member, the working member including a vertical strut, an upper beam, and a lower beam, the drive assembly movable from a retracted position to an advanced position to move the actuation sled from its retracted position to its advanced position; and

25 an anvil assembly pivotally secured to the cartridge assembly and movable in relation to the cartridge assembly between open and clamped positions, the anvil assembly including an anvil body, an anvil cover, and a lockout member, the anvil body including an anvil member having an inner surface defining a plurality of staple de-

30 forming pockets, an outer surface defining a longitudinal groove, a central knife slot extending between the inner and outer surfaces, and a through bore extending between the inner and outer surfaces, the anvil cover defining a cutout and being secured to the anvil body to define a longitudinal channel within the anvil assembly, the longitudinal channel positioned to receive the upper beam of the working member of the drive assembly, the lockout member having a horizontal portion and a vertical portion, wherein

35 the lockout member is movable from a first position in which the horizontal portion of the lockout member is positioned within the longitudinal channel of the anvil assembly to obstruct distal movement of the upper beam of the working member within the anvil assembly to a second position in which the horizontal portion of the lockout member is positioned within the cutout of the anvil cover of the anvil assembly to allow distal movement of the upper beam of the working member within the anvil assembly.

2. The surgical stapling device of paragraph 1, fur-

ther including a biasing member, the biasing member urging the lockout member towards the first position.

3. The surgical stapling device of paragraph 2, wherein the biasing member is a leaf spring. 5

4. The surgical stapling device of paragraph 2, wherein the vertical portion of the lockout member is positioned to engage the actuation sled when the actuation sled is in its retracted position. 10

5. The surgical stapling device of paragraph 4, wherein engagement between the vertical portion of the lockout member and the actuation sled moves the lockout member from the first position to the second position as the anvil and the cartridge assemblies are moved to the clamped position. 15

6. The surgical stapling device of paragraph 5, wherein the horizontal portion of the lockout member includes a tapered distal surface and a proximal stop surface. 20

7. The surgical stapling device of paragraph 6, wherein the vertical portion of the lockout member includes a spring mount, the biasing member being secured to the spring mount. 25

8. The surgical stapling device of paragraph 1, further including a dissector tip supported on the anvil body, the dissector tip having a thickness that decreases in the distal direction. 30

9. The surgical stapling device of paragraph 1, further including an elongate body having a distal portion, the cartridge assembly and the anvil assembly supported on the distal portion of the elongate body. 35

10. The surgical stapling device of paragraph 9, wherein the cartridge assembly, the anvil assembly, and the drive assembly form a reload assembly that is removable from the elongate body. 40

11. The surgical stapling device of paragraph 9, further including a handle assembly, the elongate body extending distally from the handle assembly. 45

12. A tool assembly comprising:

a cartridge assembly including a staple cartridge and an actuation sled positioned within the staple cartridge, the actuation sled movable from a retracted position to an advanced position to eject staples from the staple cartridge; and an anvil assembly pivotally secured to the cartridge assembly and movable in relation to the cartridge assembly between open and clamped positions, the anvil assembly including an anvil 50

body, an anvil cover, and a lockout member, the anvil body including an anvil member having an inner surface defining a plurality of staple deforming pockets, an outer surface defining a longitudinal groove, a central knife slot extending between the inner and outer surfaces, and a through bore extending between the inner and outer surfaces, the anvil cover defining a cutout and being secured to the anvil body to define a longitudinal channel within the anvil assembly, the lockout member having a horizontal portion and a vertical portion, wherein the lockout member is movable from a first position in which the horizontal portion of the lockout member is positioned within the longitudinal channel of the anvil assembly to a second position in which the horizontal portion of the lockout member is positioned within the cutout of the anvil cover of the anvil assembly.

13. The tool assembly of paragraph 12, further including a biasing member, the biasing member urging the lockout member towards the first position.

14. The tool assembly of paragraph 13, wherein the biasing member is a leaf spring.

15. The tool assembly of paragraph 12, wherein the vertical portion of the lockout member is positioned to engage the actuation sled when the actuation sled is in its retracted position.

16. The tool assembly of paragraph 15, wherein engagement between the vertical portion of the lockout member and the actuation sled moves the lockout member from the first position to the second position as the anvil and the cartridge assemblies are moved to the clamped position.

17. The tool assembly of paragraph 16, wherein the horizontal portion of the lockout member includes a tapered distal surface and a proximal stop surface.

18. The tool assembly of paragraph 16, wherein the vertical portion of the lockout member includes a spring mount, the biasing member being secured to the spring mount.

19. The tool assembly of paragraph 12, further including a dissector tip supported on the anvil body, the dissector tip having a thickness that decreases in the distal direction.

20. A surgical stapling device comprising:

a handle assembly;
an elongate body extending distally from the handle assembly;

a drive assembly including a flexible drive beam and a working member, the working member including a vertical strut, an upper beam, and a lower beam, the drive assembly movable from a retracted position to an advanced position to move the actuation sled from its retracted position to its advanced position; and
 a tool assembly including:

a cartridge assembly including a staple cartridge and an actuation sled positioned within the staple cartridge, the actuation sled movable from a retracted position to an advanced position to eject staples from the staple cartridge; and
 an anvil assembly pivotally secured to the cartridge assembly such that the tool assembly is movable in relation to the cartridge assembly between open and clamped positions, the anvil assembly including an anvil body, an anvil cover, and a lockout member, the anvil body including an anvil member having an inner surface defining a plurality of staple deforming pockets, an outer surface defining a longitudinal groove, a central knife slot extending between the inner and outer surfaces, and a through bore extending between the inner and outer surfaces, the anvil cover defining a cutout and being secured to the anvil body to define a longitudinal channel within the anvil assembly, the longitudinal channel positioned to receive the upper beam of the working member of the drive assembly, the lockout member having a horizontal portion and a vertical portion, wherein the lockout member is movable from a first position in which the horizontal portion of the lockout member is positioned within the longitudinal channel of the anvil assembly to obstruct distal movement of the upper beam of the working member within the anvil assembly to a second position in which the horizontal portion of the lockout member is positioned within the cutout of the anvil cover of the anvil assembly to allow distal movement of the upper beam of the working member within the anvil assembly; and
 a biasing member, the biasing member urging the lockout member towards the first position.

Claims

1. A surgical stapling device comprising:

a cartridge assembly including a staple cartridge

and an actuation sled positioned within the staple cartridge, the actuation sled movable from a retracted position to an advanced position to eject staples from the staple cartridge;
 a drive assembly including a flexible drive beam and a working member, the working member including a vertical strut, an upper beam, and a lower beam, the drive assembly movable from a retracted position to an advanced position to move the actuation sled from its retracted position to its advanced position; and
 an anvil assembly pivotally secured to the cartridge assembly and movable in relation to the cartridge assembly between open and clamped positions, the anvil assembly including an anvil body, an anvil cover, and a lockout member, the anvil body including an anvil member having an inner surface defining a plurality of staple deforming pockets, an outer surface defining a longitudinal groove, a central knife slot extending between the inner and outer surfaces, and a through bore extending between the inner and outer surfaces, the anvil cover defining a cutout and being secured to the anvil body to define a longitudinal channel within the anvil assembly, the longitudinal channel positioned to receive the upper beam of the working member of the drive assembly, the lockout member having a horizontal portion and a vertical portion, wherein the lockout member is movable from a first position in which the horizontal portion of the lockout member is positioned within the longitudinal channel of the anvil assembly to obstruct distal movement of the upper beam of the working member within the anvil assembly to a second position in which the horizontal portion of the lockout member is positioned within the cutout of the anvil cover of the anvil assembly to allow distal movement of the upper beam of the working member within the anvil assembly.

- 2. The surgical stapling device of claim 1, further including a biasing member, the biasing member urging the lockout member towards the first position.
- 3. The surgical stapling device of claim 2, wherein the biasing member is a leaf spring.
- 4. The surgical stapling device of claim 2, wherein the vertical portion of the lockout member is positioned to engage the actuation sled when the actuation sled is in its retracted position.
- 5. The surgical stapling device of claim 4, wherein engagement between the vertical portion of the lockout member and the actuation sled moves the lockout member from the first position to the second position as the anvil and the cartridge assemblies are moved

to the clamped position; preferably wherein the horizontal portion of the lockout member includes a tapered distal surface and a proximal stop surface; and/or wherein the vertical portion of the lockout member includes a spring mount, the biasing member being secured to the spring mount.

6. The surgical stapling device of any preceding claim, further including a dissector tip supported on the anvil body, the dissector tip having a thickness that decreases in the distal direction; and/or further including an elongate body having a distal portion, the cartridge assembly and the anvil assembly supported on the distal portion of the elongate body.

7. The surgical stapling device of claim 6, wherein the cartridge assembly, the anvil assembly, and the drive assembly form a reload assembly that is removable from the elongate body; preferably further including a handle assembly, the elongate body extending distally from the handle assembly.

8. A tool assembly comprising:

a cartridge assembly including a staple cartridge and an actuation sled positioned within the staple cartridge, the actuation sled movable from a retracted position to an advanced position to eject staples from the staple cartridge; and an anvil assembly pivotally secured to the cartridge assembly and movable in relation to the cartridge assembly between open and clamped positions, the anvil assembly including an anvil body, an anvil cover, and a lockout member, the anvil body including an anvil member having an inner surface defining a plurality of staple deforming pockets, an outer surface defining a longitudinal groove, a central knife slot extending between the inner and outer surfaces, and a through bore extending between the inner and outer surfaces, the anvil cover defining a cutout and being secured to the anvil body to define a longitudinal channel within the anvil assembly, the lockout member having a horizontal portion and a vertical portion, wherein the lockout member is movable from a first position in which the horizontal portion of the lockout member is positioned within the longitudinal channel of the anvil assembly to a second position in which the horizontal portion of the lockout member is positioned within the cutout of the anvil cover of the anvil assembly.

9. The tool assembly of claim 8, further including a biasing member, the biasing member urging the lockout member towards the first position; preferably wherein the biasing member is a leaf spring.

10. The tool assembly of claim 8 and claim 9, wherein the vertical portion of the lockout member is positioned to engage the actuation sled when the actuation sled is in its retracted position; preferably wherein engagement between the vertical portion of the lockout member and the actuation sled moves the lockout member from the first position to the second position as the anvil and the cartridge assemblies are moved to the clamped position.

11. The tool assembly of any of claims 8 to 10, wherein the horizontal portion of the lockout member includes a tapered distal surface and a proximal stop surface.

12. The tool assembly of any of claims 8 to 11, wherein the vertical portion of the lockout member includes a spring mount, the biasing member being secured to the spring mount.

13. The tool assembly of any of claims 8 to 12, further including a dissector tip supported on the anvil body, the dissector tip having a thickness that decreases in the distal direction.

14. A surgical stapling device comprising:

a handle assembly;
an elongate body extending distally from the handle assembly;
a drive assembly including a flexible drive beam and a working member, the working member including a vertical strut, an upper beam, and a lower beam, the drive assembly movable from a retracted position to an advanced position to move the actuation sled from its retracted position to its advanced position; and
a tool assembly including:

a cartridge assembly including a staple cartridge and an actuation sled positioned within the staple cartridge, the actuation sled movable from a retracted position to an advanced position to eject staples from the staple cartridge; and
an anvil assembly pivotally secured to the cartridge assembly such that the tool assembly is movable in relation to the cartridge assembly between open and clamped positions, the anvil assembly including an anvil body, an anvil cover, and a lockout member, the anvil body including an anvil member having an inner surface defining a plurality of staple deforming pockets, an outer surface defining a longitudinal groove, a central knife slot extending between the inner and outer surfaces, and a through bore extending between the inner and outer surfaces, the anvil cover defining

a cutout and being secured to the anvil body to define a longitudinal channel within the anvil assembly, the longitudinal channel positioned to receive the upper beam of the working member of the drive assembly, the 5
lockout member having a horizontal portion and a vertical portion, wherein the lockout member is movable from a first position in which the horizontal portion of the lockout member is positioned within the longitudinal 10
channel of the anvil assembly to obstruct distal movement of the upper beam of the working member within the anvil assembly to a second position in which the horizontal portion of the lockout member is positioned 15
within the cutout of the anvil cover of the anvil assembly to allow distal movement of the upper beam of the working member within the anvil assembly; and
a biasing member, the biasing member urging the lockout member towards the first position. 20

25

30

35

40

45

50

55

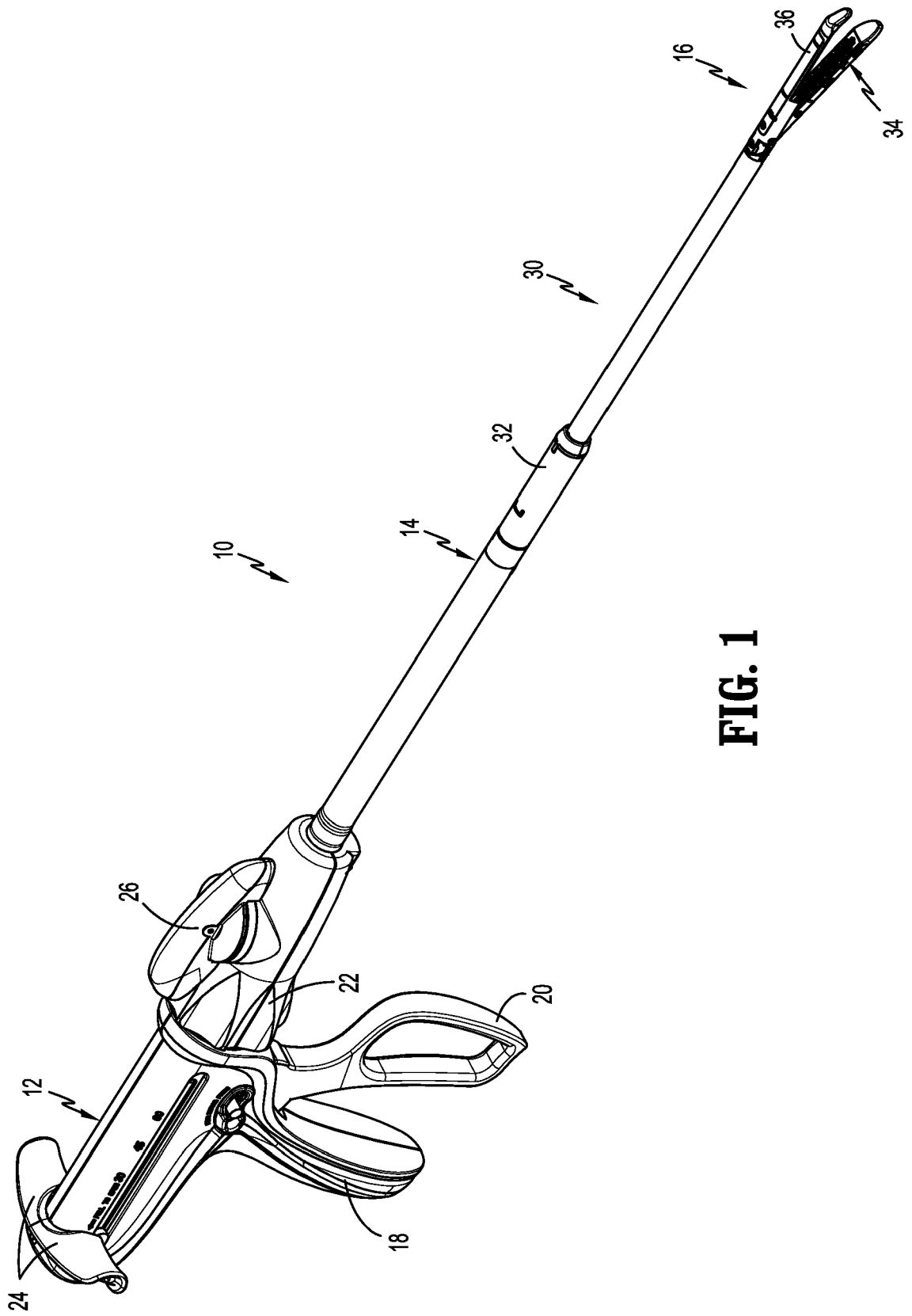

FIG. 1

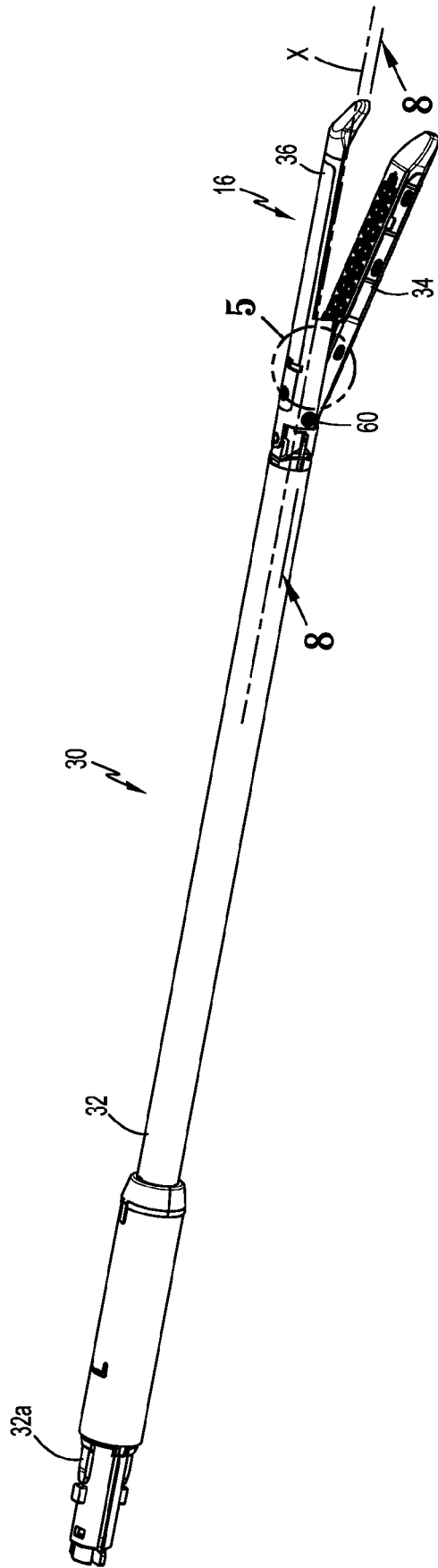

FIG. 2

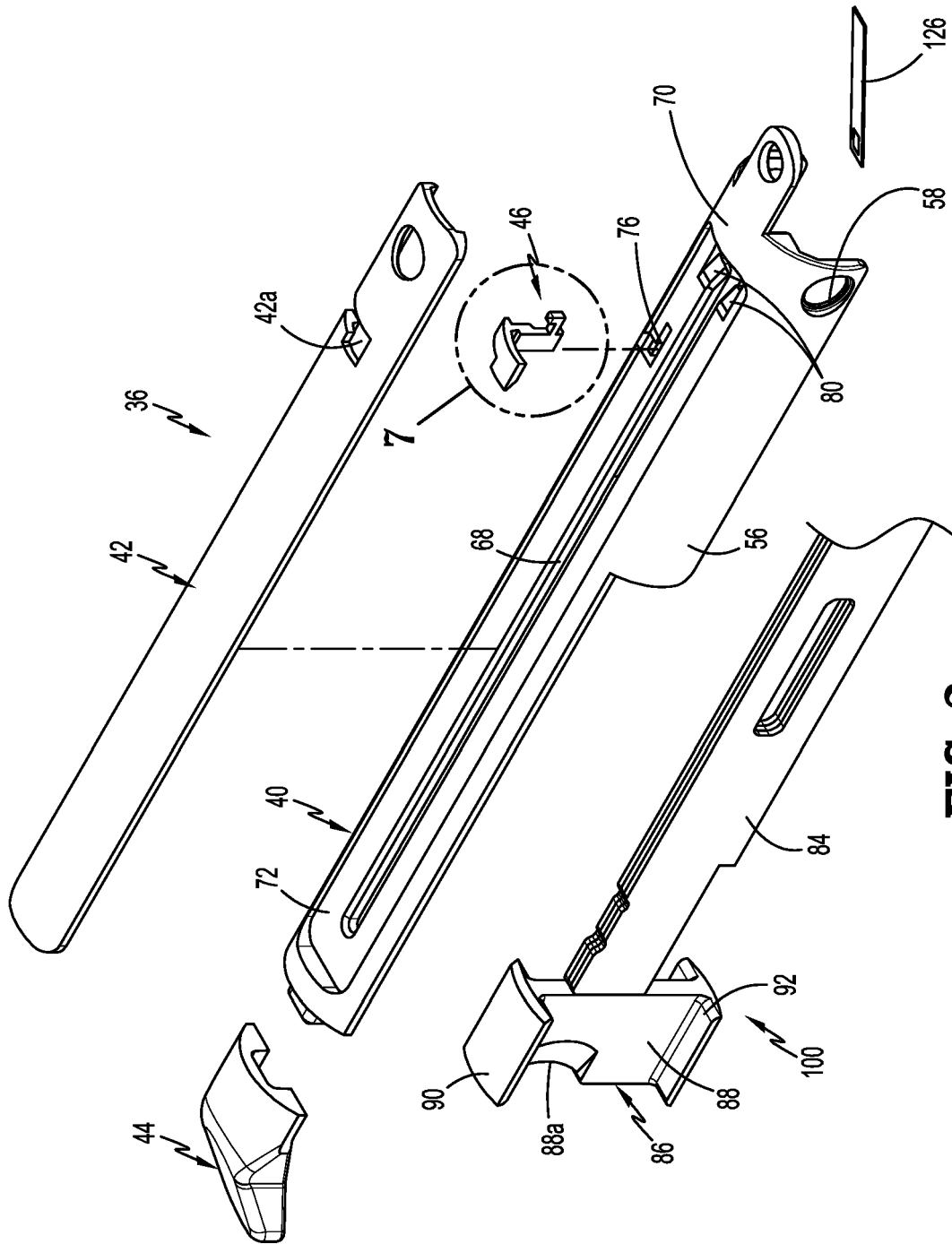

FIG. 3

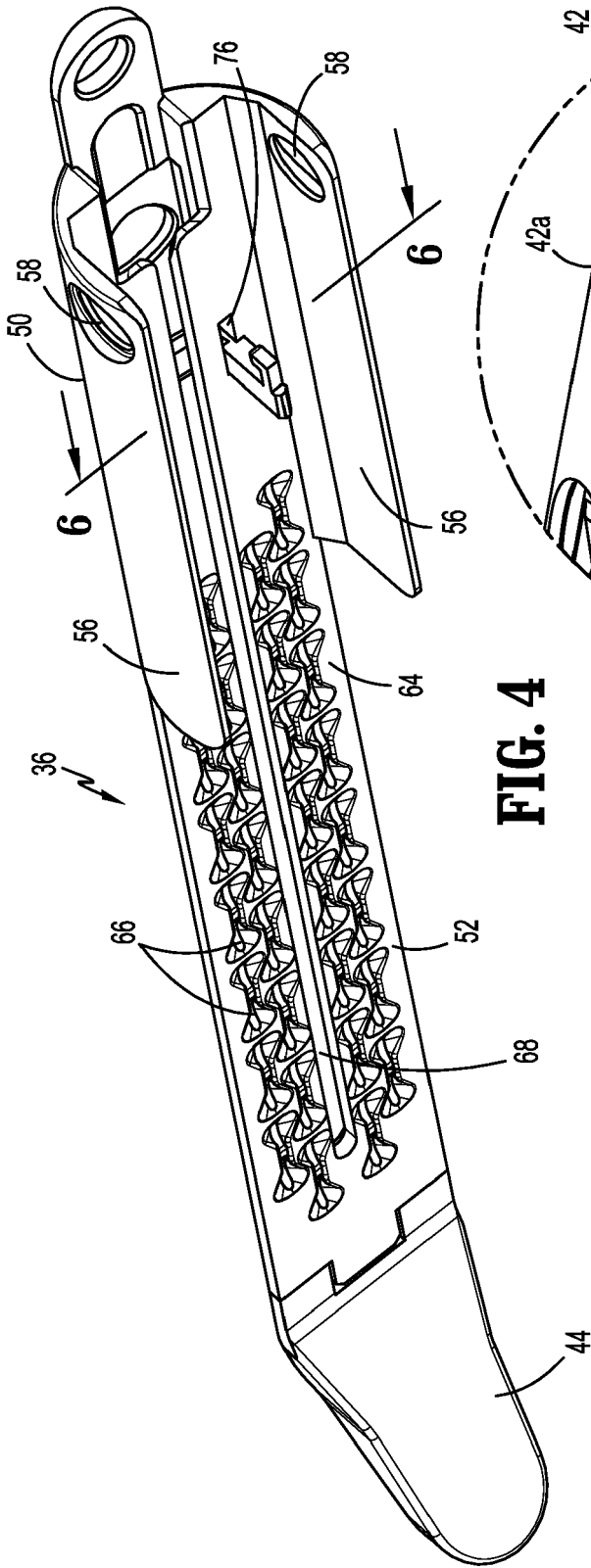

FIG. 4

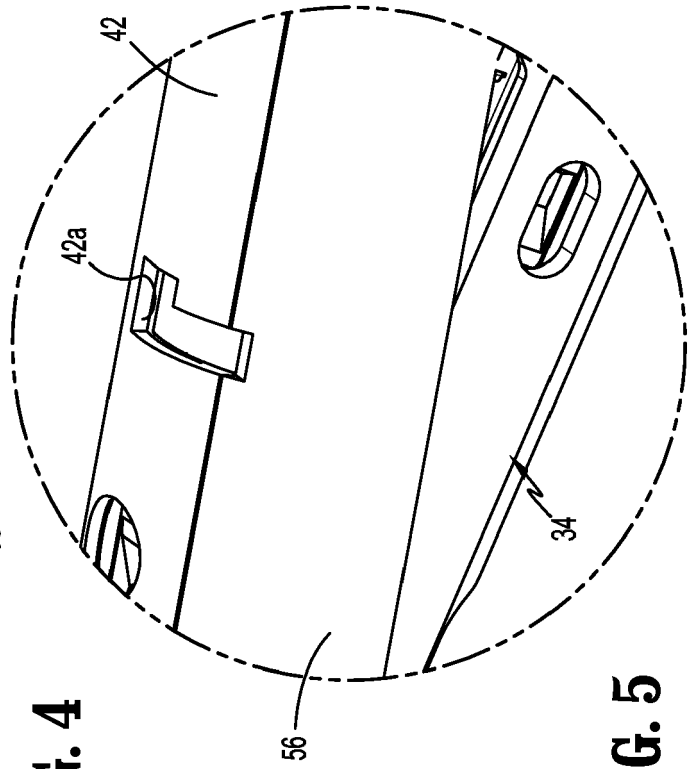

FIG. 5

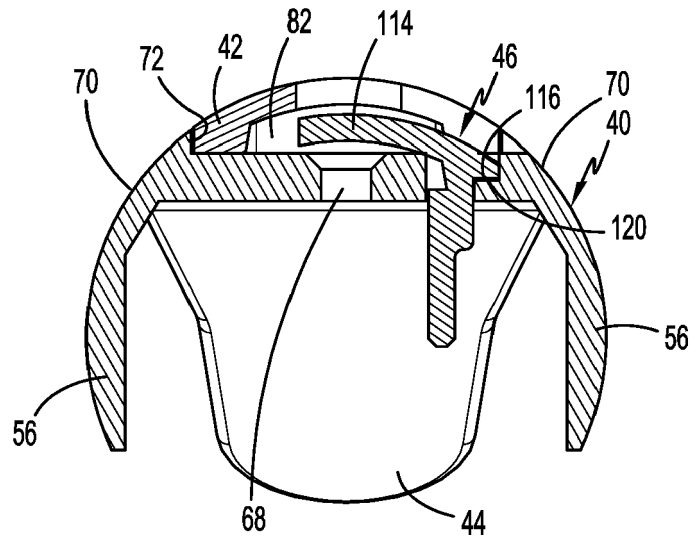

FIG. 6

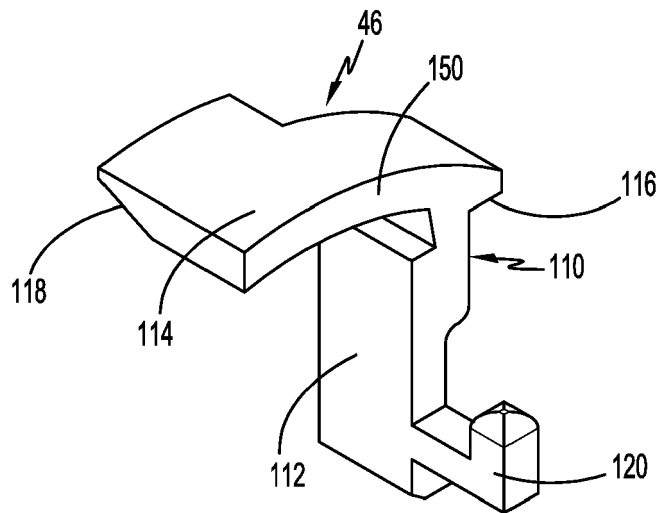

FIG. 7

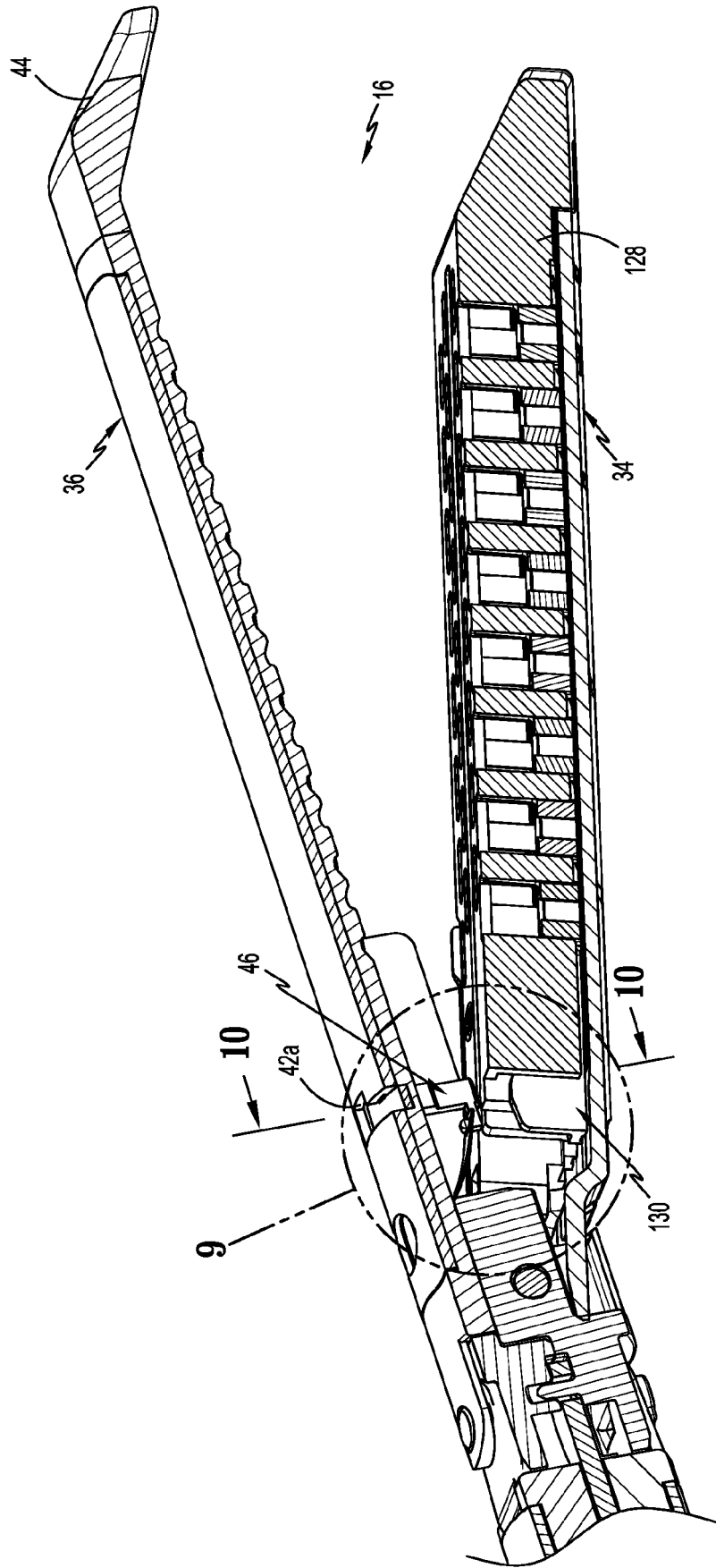

FIG. 8

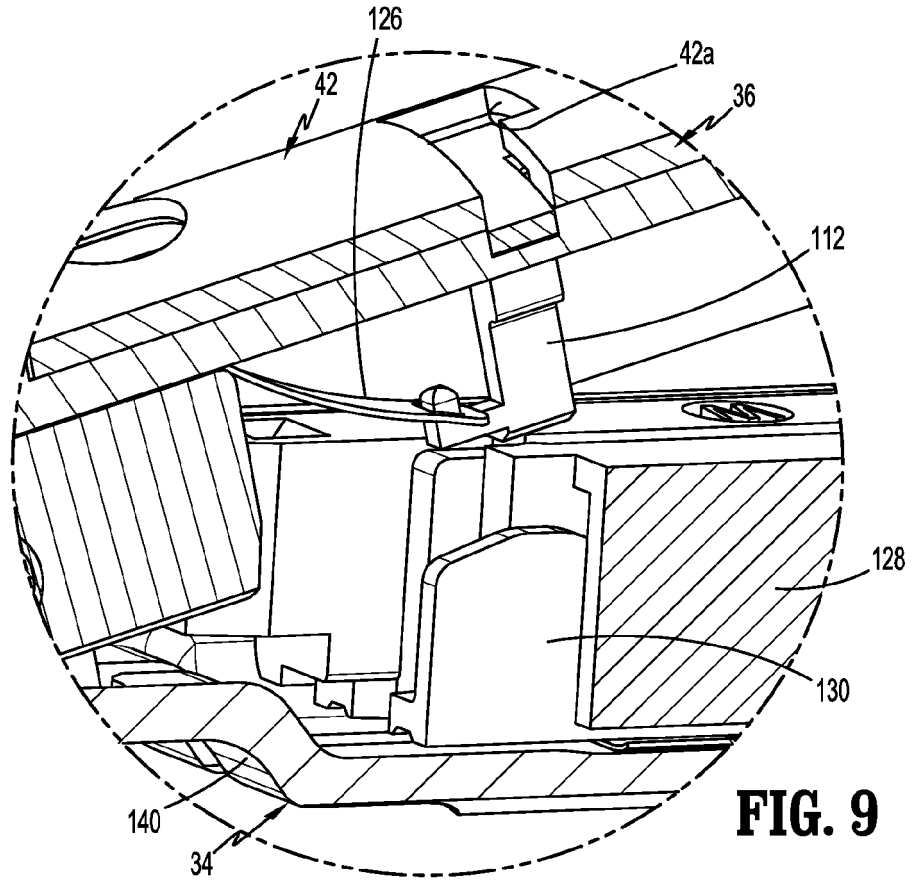

FIG. 9

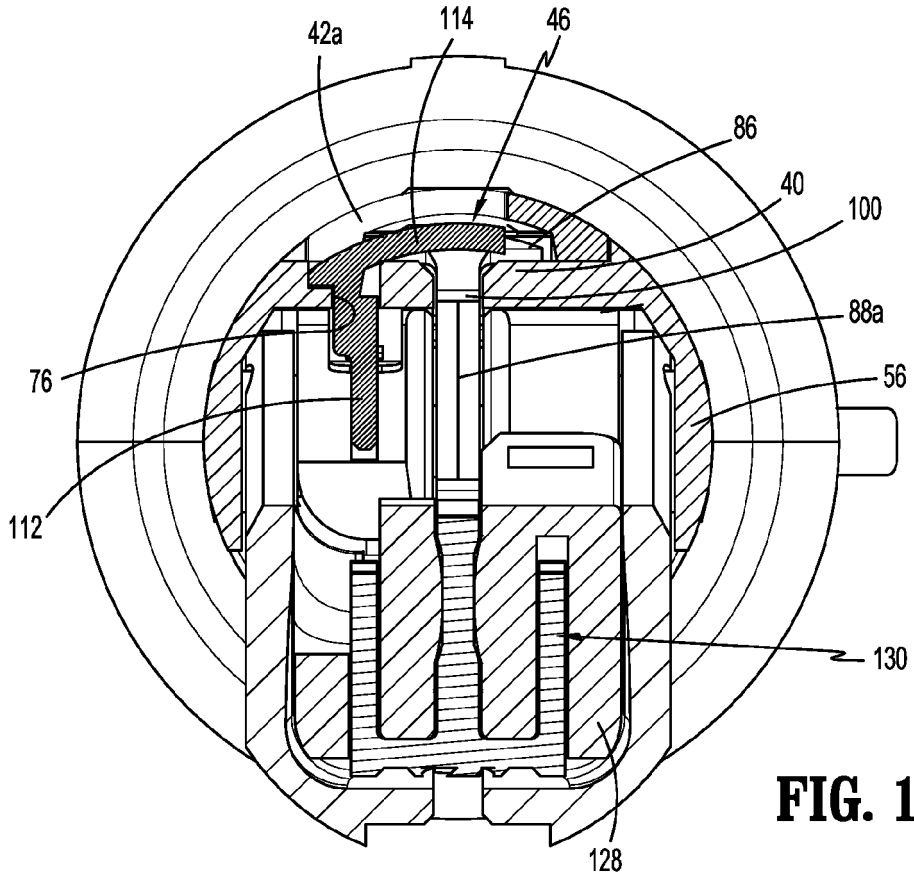

FIG. 10

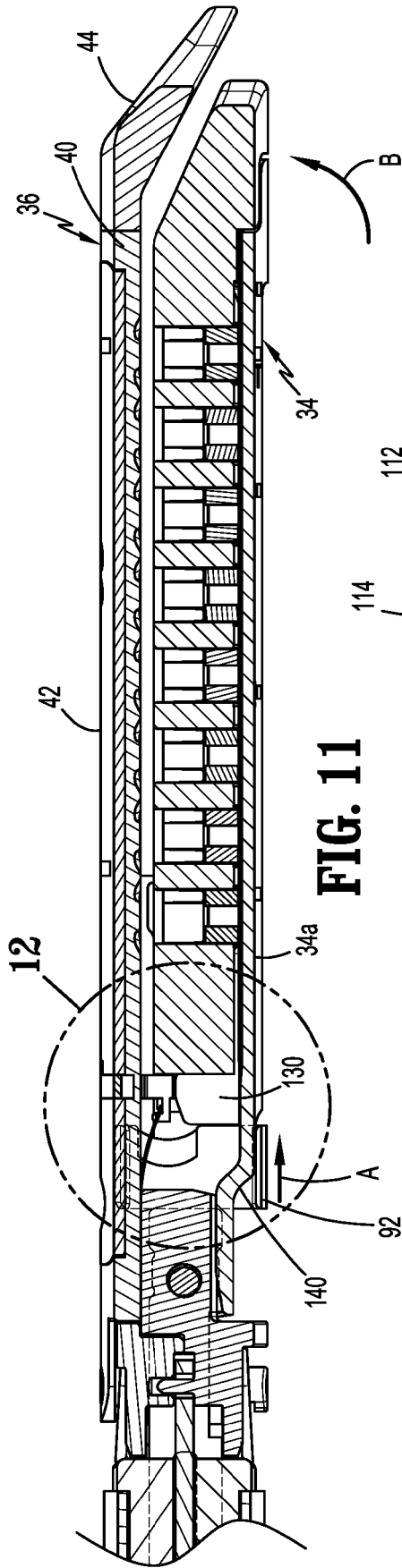

FIG. 11

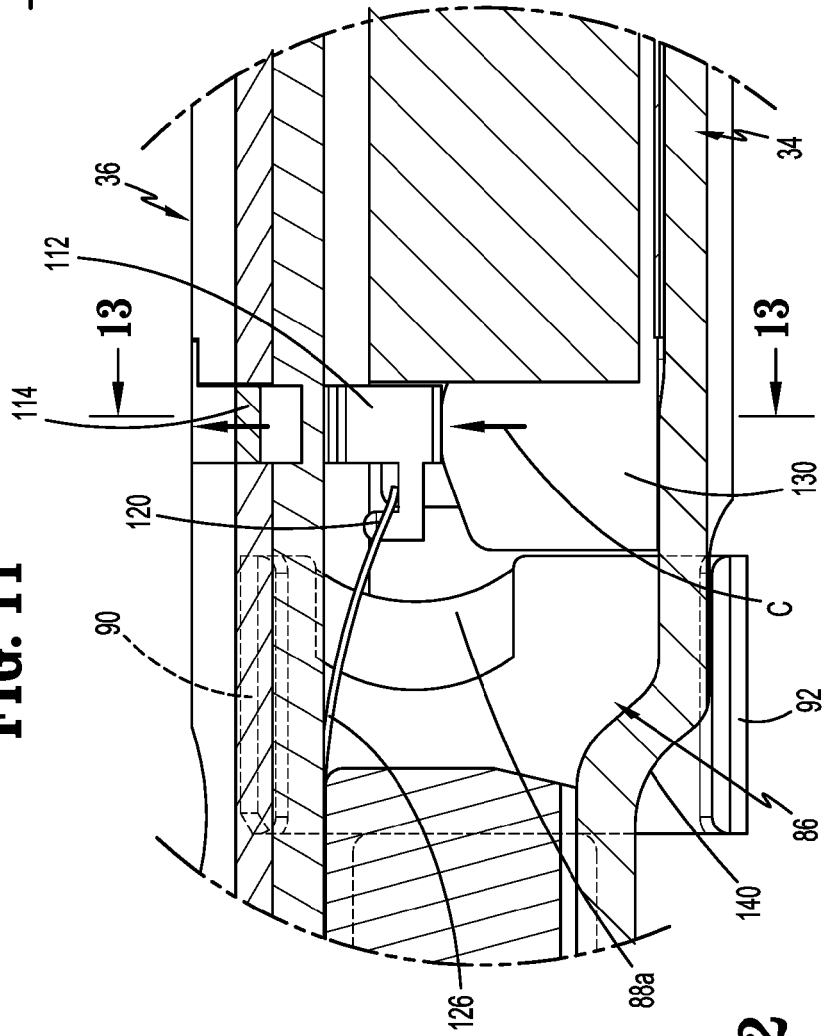

FIG. 12

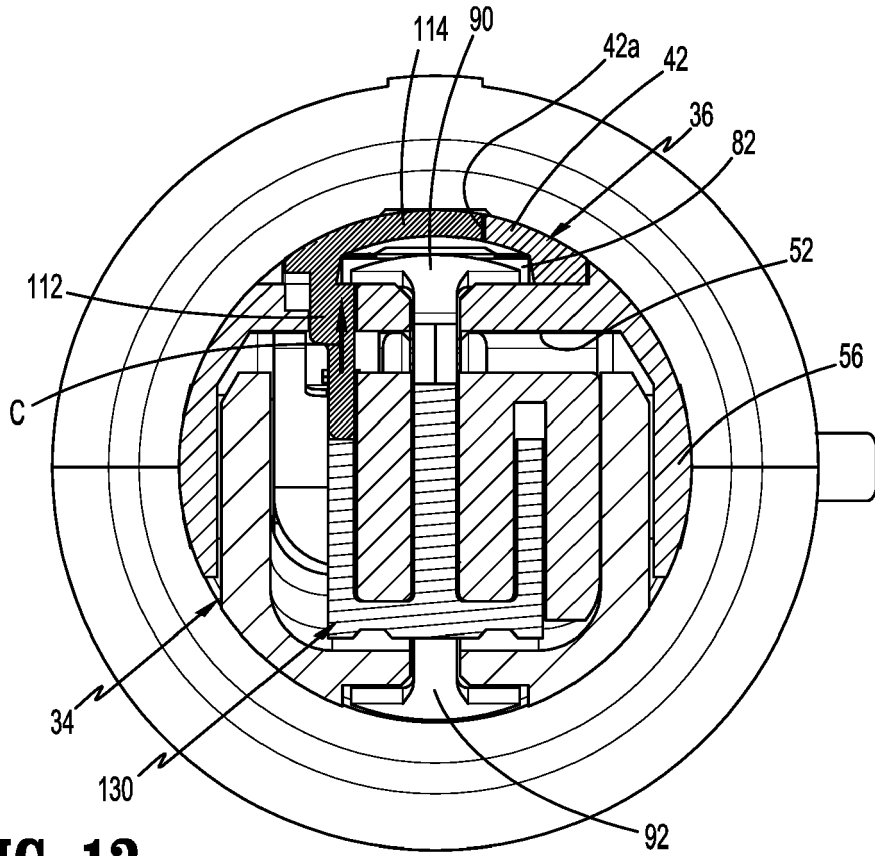

FIG. 13

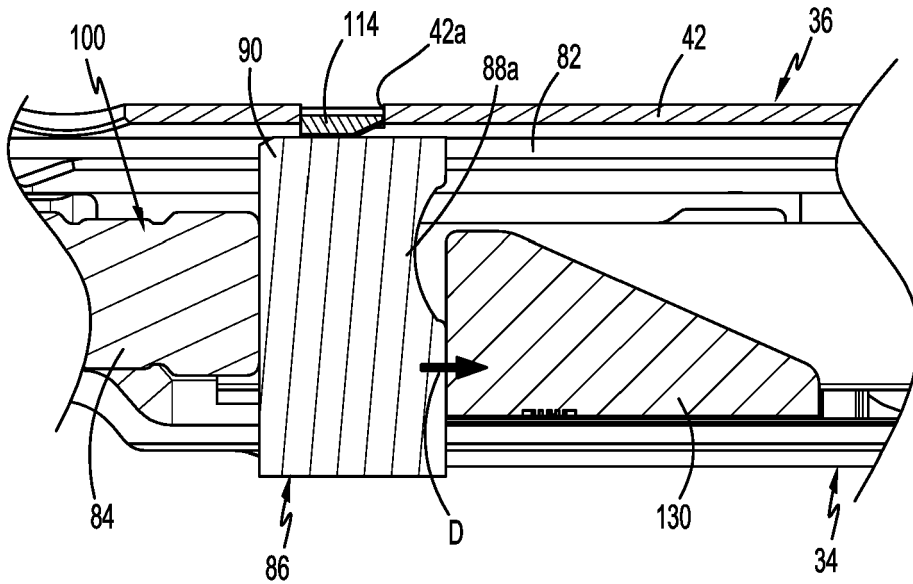

FIG. 14

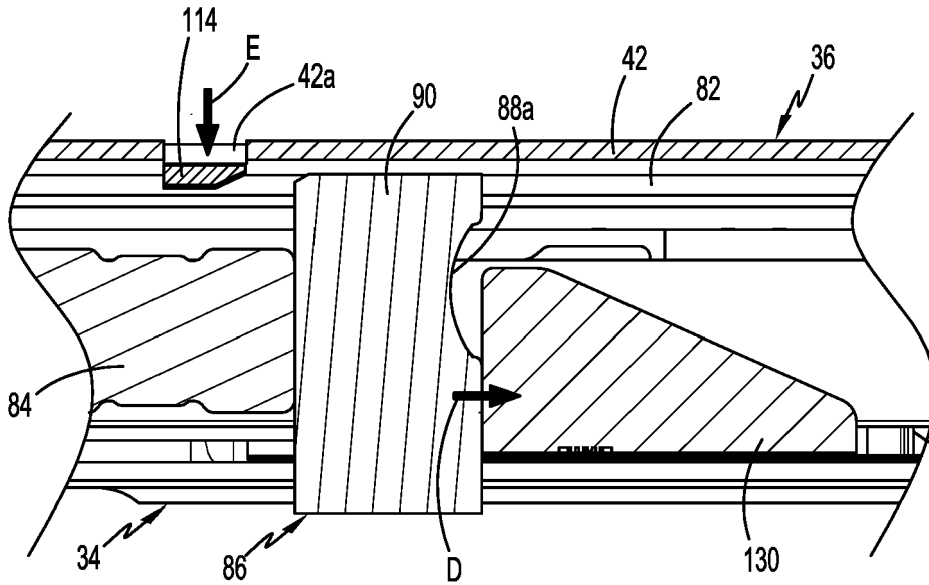

FIG. 15

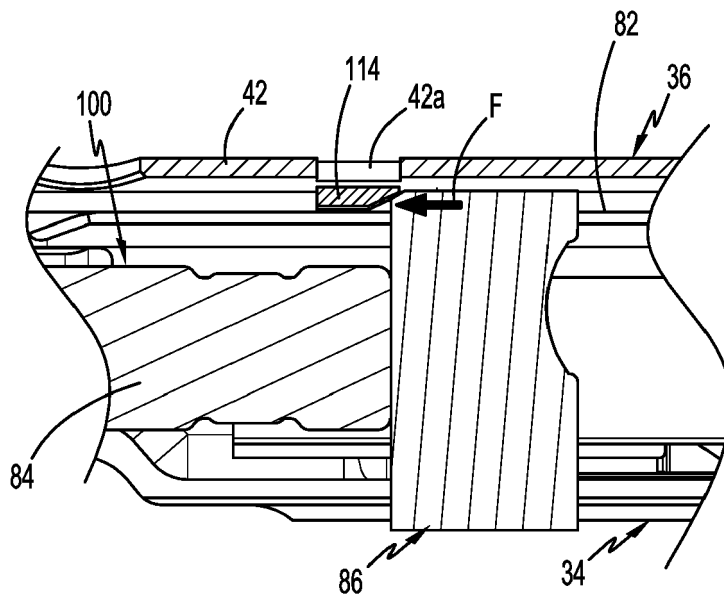

FIG. 16

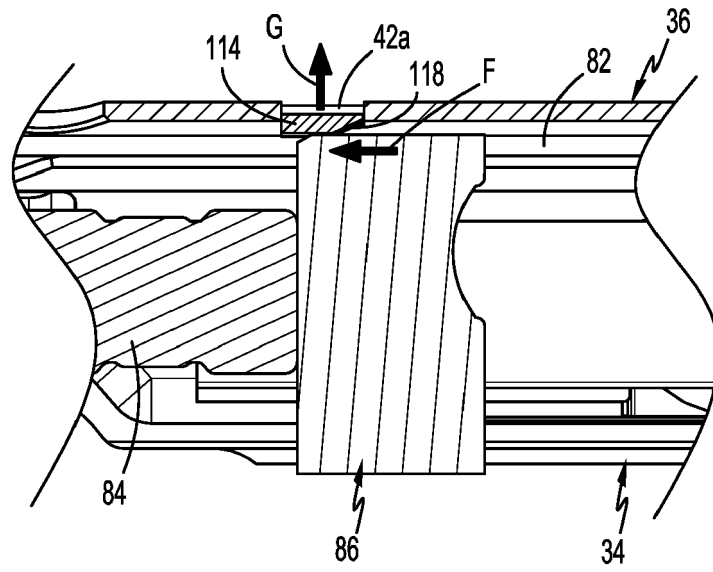

FIG. 17

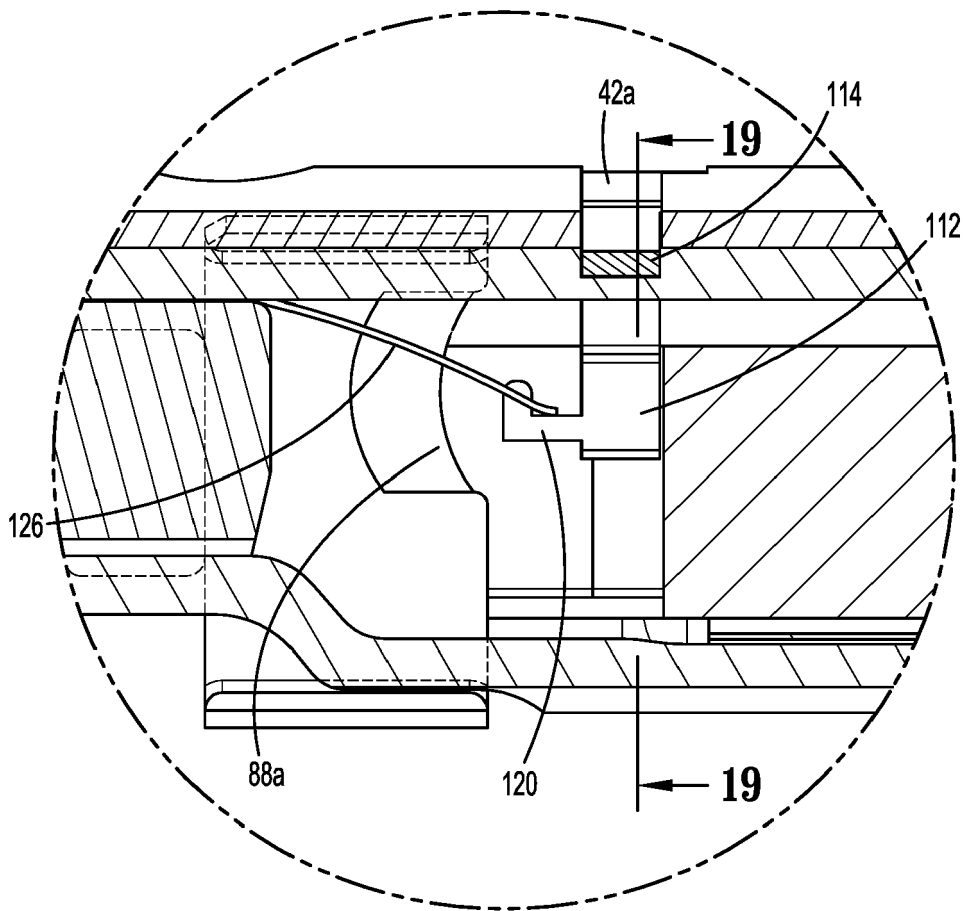

FIG. 18

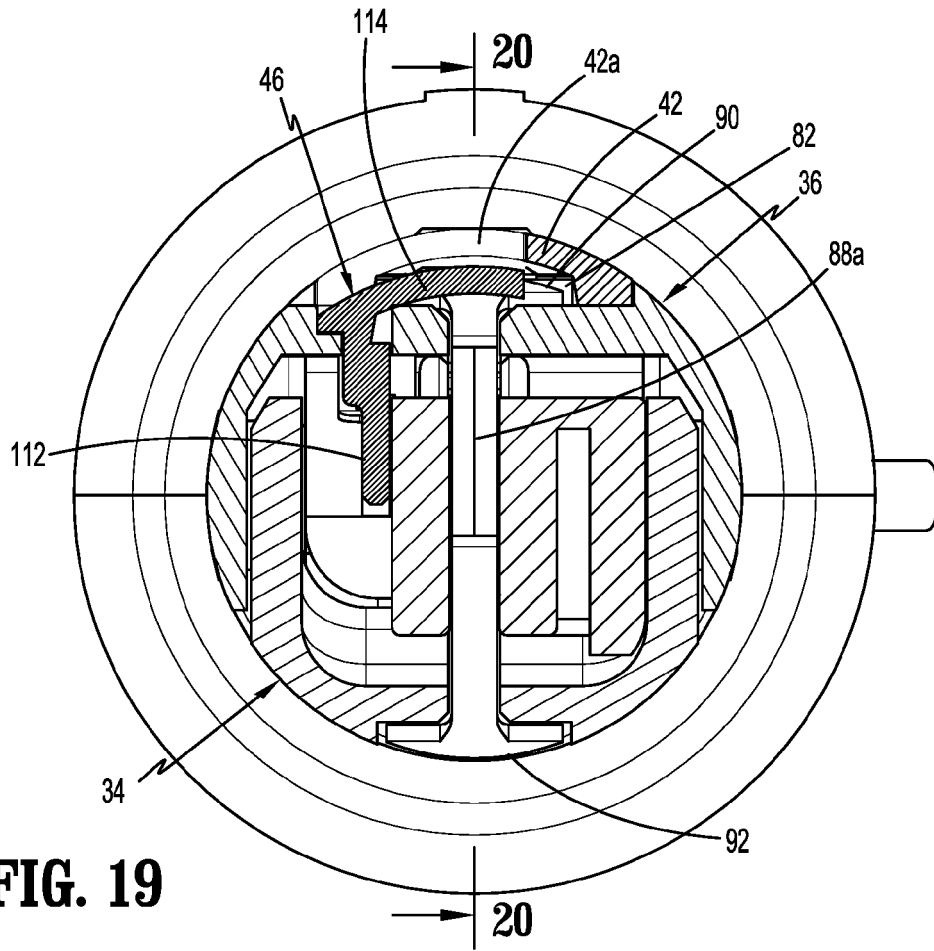

FIG. 19

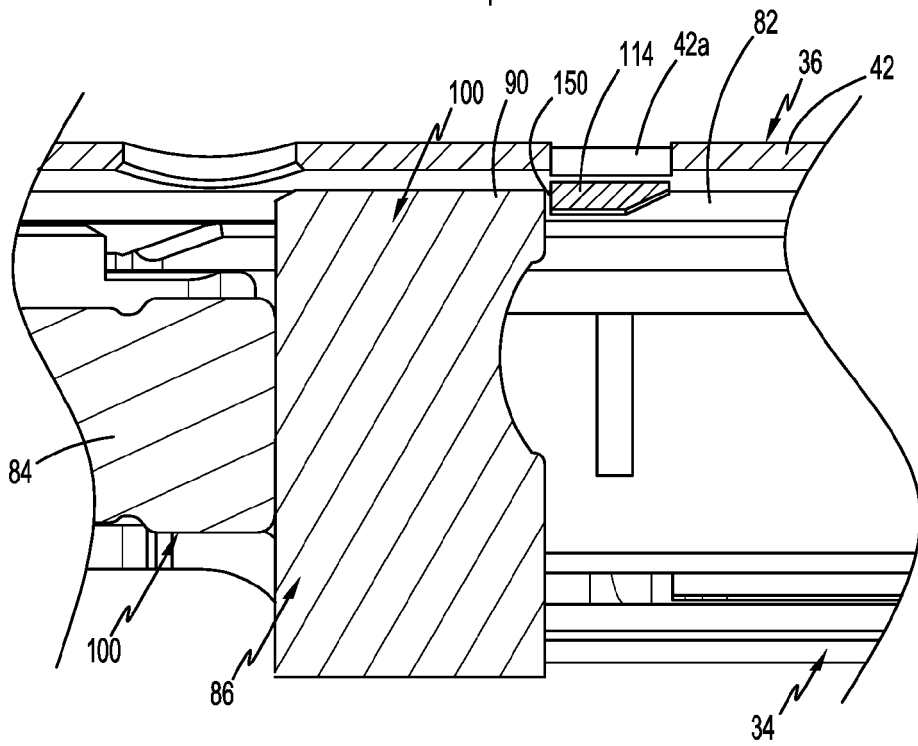

FIG. 20



EUROPEAN SEARCH REPORT

Application Number
EP 21 15 4283

5

10

15

20

25

30

35

40

45

50

55

DOCUMENTS CONSIDERED TO BE RELEVANT			
Category	Citation of document with indication, where appropriate, of relevant passages	Relevant to claim	CLASSIFICATION OF THE APPLICATION (IPC)
X	US 2019/167266 A1 (PATEL ATAL C [US] ET AL) 6 June 2019 (2019-06-06)	1,6-8, 10,11	INV. A61B17/072
Y	* figures 1A-7 *	13	
A	* paragraphs [0034] - [0045] *	2-5,9, 12,14	ADD. A61B17/29 A61B17/00 A61B90/00

Y	EP 3 446 642 A2 (COVIDIEN LP [US]) 27 February 2019 (2019-02-27)	13	
	* figures 8A, 8B *		
	* paragraphs [0047], [0048] *		

A	EP 2 777 529 A1 (COVIDIEN LP [US]) 17 September 2014 (2014-09-17)	1-14	
	* figures 93-104 *		
	* paragraphs [0121] - [0132] *		

A	EP 1 479 348 A1 (ETHICON ENDO SURGERY [US]) 24 November 2004 (2004-11-24)	1-14	
	* figures 25-34 *		
	* paragraphs [0084] - [0094] *		

			TECHNICAL FIELDS SEARCHED (IPC)
			A61B
The present search report has been drawn up for all claims			
Place of search Munich		Date of completion of the search 12 March 2021	Examiner Schleich, Florian
CATEGORY OF CITED DOCUMENTS		T : theory or principle underlying the invention E : earlier patent document, but published on, or after the filing date D : document cited in the application L : document cited for other reasons & : member of the same patent family, corresponding document	
X : particularly relevant if taken alone Y : particularly relevant if combined with another document of the same category A : technological background O : non-written disclosure P : intermediate document			

EPO FORM 1503 03.82 (P04C01)

ANNEX TO THE EUROPEAN SEARCH REPORT
ON EUROPEAN PATENT APPLICATION NO.

EP 21 15 4283

5 This annex lists the patent family members relating to the patent documents cited in the above-mentioned European search report.
The members are as contained in the European Patent Office EDP file on
The European Patent Office is in no way liable for these particulars which are merely given for the purpose of information.

12-03-2021

Patent document cited in search report	Publication date	Patent family member(s)	Publication date
US 2019167266 A1	06-06-2019	NONE	
EP 3446642 A2	27-02-2019	AU 2018211209 A1 CA 3012790 A1 EP 3446642 A2 JP 2019037765 A US 2019059896 A1 US 2021045744 A1	14-03-2019 23-02-2019 27-02-2019 14-03-2019 28-02-2019 18-02-2021
EP 2777529 A1	17-09-2014	AU 2014200912 A1 CA 2844607 A1 CN 104042272 A EP 2777529 A1 ES 2627328 T3 JP 2014176674 A US 2014263567 A1	02-10-2014 13-09-2014 17-09-2014 17-09-2014 27-07-2017 25-09-2014 18-09-2014
EP 1479348 A1	24-11-2004	AT 400221 T AU 2004202201 A1 AU 2007216766 A1 AU 2010202270 A1 BR PI0703691 A CA 2467881 A1 CA 2605353 A1 CN 101268954 A EP 1479348 A1 EP 1908416 A1 ES 2309464 T3 JP 4703977 B2 JP 2004344659 A KR 20080031127 A MX PA04004883 A PL 1479348 T3 SG 141407 A1 US 2004232195 A1 US 2007084896 A1 ZA 200708416 B	15-07-2008 09-12-2004 17-04-2008 24-06-2010 27-05-2008 20-11-2004 03-04-2008 24-09-2008 24-11-2004 09-04-2008 16-12-2008 15-06-2011 09-12-2004 08-04-2008 25-11-2004 31-12-2008 28-04-2008 25-11-2004 19-04-2007 30-09-2009

REFERENCES CITED IN THE DESCRIPTION

This list of references cited by the applicant is for the reader's convenience only. It does not form part of the European patent document. Even though great care has been taken in compiling the references, errors or omissions cannot be excluded and the EPO disclaims all liability in this regard.

Patent documents cited in the description

- US 62968222 [0001]
- US 9055943 B [0022]
- US 6241139 B [0022]