

(19)



(11)

EP 3 875 875 B1

(12)

EUROPEAN PATENT SPECIFICATION

(45) Date of publication and mention of the grant of the patent:

13.12.2023 Bulletin 2023/50

(51) International Patent Classification (IPC):
F25C 1/25^(2018.01)

(52) Cooperative Patent Classification (CPC):
F25C 1/25; F25C 2400/12; F25C 2500/06

(21) Application number: **20186378.4**

(22) Date of filing: **17.07.2020**

(54) **A COOLING APPLIANCE HAVING AN ICEMAKER**

KÜHLGERÄT MIT EISBEREITER

APPAREIL DE REFROIDISSEMENT DOTÉ D'UNE MACHINE À GLAÇONS

(84) Designated Contracting States:

**AL AT BE BG CH CY CZ DE DK EE ES FI FR GB
GR HR HU IE IS IT LI LT LU LV MC MK MT NL NO
PL PT RO RS SE SI SK SM TR**

(30) Priority: **04.07.2019 TR 201909984**

(43) Date of publication of application:
08.09.2021 Bulletin 2021/36

(73) Proprietor: **Arçelik Anonim Sirketi
34445 Istanbul (TR)**

(72) Inventors:

- **SAHIN, Burhan
34445 ISTANBUL (TR)**
- **CANIGUR, Ibrahim
34445 ISTANBUL (TR)**
- **YILDIZ, Faruk
34445 ISTANBUL (TR)**

(56) References cited:

**WO-A1-2004/071964 WO-A1-2014/084506
KR-B1- 101 564 263 US-B2- 8 800 315**

EP 3 875 875 B1

Note: Within nine months of the publication of the mention of the grant of the European patent in the European Patent Bulletin, any person may give notice to the European Patent Office of opposition to that patent, in accordance with the Implementing Regulations. Notice of opposition shall not be deemed to have been filed until the opposition fee has been paid. (Art. 99(1) European Patent Convention).

Description

[0001] The present invention relates to a cooling appliance having an ice maker wherein the ice maker comprises a water damper to damp the flow of the water.

[0002] The modern cooling appliances are provided with automatic ice makers. The ice makers are provided with a pipe to supply water to the ice maker. The said ice makers are filled with water and after a certain amount of time, the ice maker is bent via a motor and the newly formed ice cubes are ejected from the ice maker. The cooling appliance keeps forming and storing ice cubes until a predetermined level of ice is obtained. Due to the automatic structure such ice making systems have, the users have limited possibilities of intervention. As a result of this, as the water is filled inside the ice maker, some of the water overflows or splashes forming ice near or on the ice maker. This causes malfunctions and physical damage to the ice maker.

[0003] A prior art publication in the technical field of the present invention may be referred to as US2019128595A1 among others, the document disclosing a cooling appliance having an automatic ice maker.

[0004] A prior art publication in the technical field of the present invention may be referred to as WO2014084506A1 others, the document disclosing a cooling appliance having an ice maker and an ice transfer means.

[0005] US8800315B2 discloses a refrigerator having a water supply unit connected to a water supply passage to temporarily store the supplied water, thereby stably supplying water disposed above an ice making apparatus.

[0006] An objective of the present invention is to provide a cooling appliance having an ice maker and a water damper to prevent overflow of water.

[0007] Claim 1 defines a cooling appliance having an ice maker. The ice maker is placed inside the freezing compartment or inside the fresh food compartment and is isolated from fresh food compartment so as to keep the surrounding temperature of the ice maker below zero. In a preferred embodiment, the ice maker is placed on to the rear surface of a door of the cooling appliance. A pipe is positioned above the ice maker and supplies water to the ice maker. A water damper is placed above the ice maker and is configured to guide and damp the water supplied by the pipe. The water damper is in conical shape with its diameter gradually decreasing from top to bottom meaning that towards the ice maker. A guide is provided in the form of a protrusion on the inner surface the ice maker. The guide forms a spiral in a first direction which helps forming a vortex in the first direction. The helps to prevent the overflow of the water being poured inside the water damper. By this means, the water is prevented to overflow the water damper which in time will accumulate in the form of ice on or in close vicinity of the ice maker. The formation of ice causes the ice maker to malfunction.

[0008] In an embodiment of the invention, a cover is removably placed on to the water damper. The cover is concave shaped and protrudes upwards. The cover comprises an opening through which the pipe passes through. By means of the cover, the overflow of water is further minimized.

[0009] In an embodiment of the invention, the area of the opening is substantially smaller than the area of the cover. By means of the opening being substantially smaller than the cover, the pipe after passing through the opening, almost no gap remains in between the pipe and the cover.

[0010] In an embodiment of the invention, the water damper is made of an elastic material. The water damper is collapsible reversible upon being pushed on. It reverses in vertical direction. After the water damper is reversed so as to be inside out, the guide remains outside the water damper. The guide is symmetrical with respect to the water damper, therefore forming a secondary guide inside the water damper and the spiral shape. This time the spiral shape of the guide is in a second direction opposite to the first direction. By this means, the user may use the same water damper to efficiently damp the water both in northern and southern hemisphere.

[0011] In an embodiment of the invention, a heater is coiled around the pipe so as to prevent blockage of the pipe by gradual formation of the ice inside the pipe.

[0012] In an embodiment of the invention, the pipe comprises an outlet wherein the outlet is at least partly placed inside the cover via the opening. The extension direction of the outlet is bent with respect to the extension direction of the pipe. By this means, the water is diverted towards the water damper and to the guide.

[0013] In an embodiment of the invention, the outlet comprises a bottleneck wherein the cross sectional area of the outlet decreases. By means of the bottleneck, the water is slowed down and dispersed which in turn helps to prevent overflow.

[0014] In the cooling appliance of the present invention, the ice maker is provided with the water damper that helps guide the flow of water inside via the guide, preventing the overflow of water.

[0015] The drawings are not meant to delimit the scope of protection as identified in the claims nor should they be referred to alone in an effort to interpret the scope identified in the claims without recourse to the technical disclosure in the description of the present invention.

Figure 1 - is a front view of the cooling appliance

Figure 2 - is an isolated view of the door of the cooling appliance

Figure 3 - is a cross sectional view of the door along the dashed line A-A in Figure 2

Figure 4 - is an enlarged view of the dashed line B-B in Figure 3

Figure 5 - is an isolated view of the ice maker in connection with the water damper

[0016] The following numerals are assigned to different parts demonstrated in the drawings and referred to in the present detailed description of the invention:

1. Cooling appliance
2. Ice maker
3. Pipe
4. Water damper
5. Guide
6. Cover
7. Opening
8. Heater
9. Outlet

[0017] The present invention relates to a cooling appliance (1) comprising; an ice maker (2) configured to generate ice cubes, a pipe (3) to supply water to the ice maker (2), a water damper (4) positioned above the ice maker (2) to receive the water from the pipe (3) and wherein the water damper (4) has a conical shape with a diameter gradually decreasing from top to the bottom.

[0018] The present invention relates to the cooling appliance (1) further comprising a guide (5) in the form of a protrusion forming a spiral in a first direction extending in the vertical direction on the inner surface of the water damper (4) guiding the flow of the water to flow at least partially along itself. The cooling appliance (1) of the present invention comprises the ice maker (2). The ice maker (2) is placed inside the freezing compartment of the cooling appliance (1) wherein the inner temperature of the freezing compartment is below freezing point of water. It is equally possible that the ice maker (2) may be located inside the fresh food compartment. In such case, the ice maker is isolated from the fresh food compartment via a plurality of walls so as to keep temperature in close vicinity of the ice maker below zero. It is also equally possible that the ice maker (2) may be located on the rear surface of a door of the cooling appliance (1). The water is supplied to the ice maker (2) via the pipe (3). The pipe (3) is connected to a reservoir provided inside or in close vicinity of the cooling appliance (1) or directly to a main. The water damper (4) is positioned above the ice maker (2) and is configured to damp and guide the flow of the water as the water from the pipe (3) flows inside the water damper (4). The water damper (4) is in conical shape with the diameter decreasing towards the ice maker (2). Therefore, the water passes through the pipe (3), the water damper (4) and reaches the ice maker (2) respectively. The conical shape the water damper (4) has helps reduce the splash of the water as the water emerges from the pipe (3) and contacts the water damper (4). The water damper (4) comprises the guide (5) on the inner surface of the water damper (4). The guide (5) is in the form of a protrusion and forms the spiral inside the water damper in the first direction. The water flows at least partly along the guide (5) therefore creating a vortex which in turn helps the water flow and reduce the splash of water outside the water damper (4).

By means of the water damper (4) and the guide (5) the water is prevented to splash which helps reduce accumulation of water and therefore that of the ice near or in close vicinity of the ice maker (2) which causes malfunction of the ice maker (2) in the long run. Therefore, easier operation of the ice maker (2) is provided for the user.

[0019] In an embodiment, the cooling appliance (1) comprises a cover (6) removably placed onto the water damper (4) wherein the cover (6) comprises an opening (7) provided thereon through which the pipe (3) is seated. The cover (6) is concave shaped and protrudes upwards. The cover (6) comprises the opening (7) through which the pipe (3) is partly inserted. By means of the cover (6), the water is prevented to overflow the water damper (4) helping reduce the unwanted formation of ice in close vicinity or near the ice maker (2). The opening on the other hand provides the pipe (3) to be seated in between the cover (6) and the opening (7). The cover (7) further helps to eliminate the splash of water and therefore, accumulation of ice near or in close vicinity of the ice maker (2).

[0020] In a preferred embodiment the area of the opening (7) is substantially smaller than the area of the cover (6). The area covered by the opening (7) is smaller than the area covered by the cover (6) which helps to minimize the risk of ice accumulation near or in close vicinity of the ice maker (2).

[0021] In a preferred embodiment the water damper (4) is removably placed above the ice maker (2) and that the water damper (4) is made of an elastic material and that the water damper (4) is collapsible reversible along the vertical direction which upon being reversed can be placed above the ice maker (2) changing the direction of the spiral to a second direction opposite to the first direction. The water damper (4) is made of an elastic material such as silicone or similar. The water damper (4) can be removed from its place and is configured to be collapsible reversible and put back into the place so as to be positioned above the ice maker (2). Upon reversing the water damper (4), the guide (5) will also be reversed. In such case the guide (5) is configured to remain inside the water damper (4) in the form of a protrusion forming a spiral in the second direction extending in the vertical direction on the inner surface of the water damper (4) guiding the flow of the water to flow at least partially along itself. As the water flows, it tends to form a vortex in counter clockwise direction in the norther hemisphere. The guide (5) forms a spiral in the first direction corresponding to the counter clockwise direction. Likewise, the technicians or the user may revers the water damper (4) in the southern hemisphere, therefore changing the direction of the spiral to the second direction corresponding to the clockwise direction. By this means, the water damper (4) can be efficiently used for both norther hemisphere and southern hemisphere meanwhile minimizing the splash of water.

[0022] In a preferred embodiment the cooling appliance (1) comprises a heater (8) coiling around the pipe (3). The heater (8) coils around the pipe (3) preventing

formation of ice inside the pipe (3) which in turn will cause the ice maker (2) to malfunction.

[0023] In a preferred embodiment the pipe (3) comprises an outlet (9) via which the pipe (3) is seated through the opening (8) and wherein the outlet (9) is configured to bend with respect to an extension direction of the pipe (3). The extension direction of the outlet (9) and the extension direction of the pipe (3) forms an angle in between. By this means the outlet (9), water is directed towards the inner volume of the water damper (4). This helps minimize the amount of water overflowing the water damper (4).

[0024] In a preferred embodiment the outlet (9) comprises a bottleneck. The bottleneck is used for slowing down and dispersing the water flowing through the pipe (3). This helps minimize the amount of water overflowing the water damper (4).

[0025] In the cooling appliance (1) of the present invention, the cooling appliance (1) is provided with the ice maker (2) and the water damper (4) to be used with the ice maker (2) wherein the water damper (4) is in conical shape to damp and guide the water therefore preventing overflow of water which in turn causes formation of ice. Another advantageous effect provided thanks to the reversible collapsible structure the water damper (4) has is that the water damper (4) can be efficiently used both in northern and southern hemisphere.

Claims

1. A cooling appliance (1) comprising;
 - an ice maker (2) configured to generate ice cubes,
 - a pipe (3) to supply water to the ice maker (2),
 - a water damper (4) positioned above the ice maker (2) to receive the water from the pipe (3) and wherein the water damper (4) has a conical shape with a diameter gradually decreasing from top to the bottom,
 - characterized by** a guide (5) in the form of a protrusion forming a spiral in a first direction extending in the vertical direction on the inner surface of the water damper (4) guiding the flow of the water to flow at least partially along itself.
2. A cooling appliance (1) according to claim 1, **characterized by** a cover (6) removably placed onto the water damper (4) wherein the cover (6) comprises an opening (7) provided thereon through which the pipe (3) is seated.
3. A cooling appliance (1) according to claim 2, **characterized in that** the area of the opening (7) is substantially smaller than the area of the cover (6).
4. A cooling appliance (1) according to any of the pro-

ceeding claims, **characterized in that** the water damper (4) is removably placed above the ice maker (2) and that the water damper (4) is made of an elastic material and that the water damper (4) is collapsible reversible along the vertical direction which upon being reversed can be placed above the ice maker (2) changing the direction of the spiral to a second direction opposite to the first direction.

5. A cooling appliance (1) according to any of the preceding claims, **characterized by** a heater (8) coiling around the pipe (3).
6. A cooling appliance (1) according to claims 2 to 5, **characterized in that** the pipe (3) comprises an outlet (9) via which the pipe (3) is seated through the opening (7) and wherein the outlet (9) is configured to bend with respect to an extension direction of the pipe (3).
7. A cooling appliance (1) according to claim 6, **characterized in that** the outlet (9) comprises a bottleneck.

Patentansprüche

1. Ein Kühlgerät (1) umfasst:

- einen Eisbereiter (2), der zum Erzeugen von Eiswürfeln konfiguriert ist,
- ein Rohr (3) zur Wasserversorgung des Eisbereiters (2),
- einen Wasserdämpfer (4), der oberhalb des Eisbereiters (2) angeordnet ist, um das Wasser aus dem Rohr (3) aufzunehmen, und wobei der Wasserdämpfer (4) eine konische Form mit einem von oben nach unten stufenweise abnehmenden Durchmesser aufweist,
- gekennzeichnet ist es durch** eine Führung (5) in Form eines Vorsprungs, der eine Spirale in einer ersten Richtung bildet, die sich in vertikaler Richtung auf der Innenfläche des Wasserdämpfers (4) erstreckt und den Wasserstrom so leitet, dass er zumindest teilweise an sich selbst entlang fließt.
2. Ein Kühlgerät (1), wie in Anspruch 1 aufgeführt, **ist dadurch gekennzeichnet, dass** eine Abdeckung (6) abnehmbar auf dem Wasserdämpfer (4) angebracht ist, wobei die Abdeckung (6) eine darauf vorgesehene Öffnung (7) aufweist, durch die das Rohr (3) sitzt.
3. Ein Kühlgerät (1), wie in Anspruch 2 aufgeführt, **ist dadurch gekennzeichnet, dass** die Fläche der Öffnung (7) wesentlich kleiner ist als die Fläche der Abdeckung (6).

4. Ein Kühlgerät (1), wie in einem der vorherigen Ansprüchen aufgeführt, **ist dadurch gekennzeichnet, dass** der Wasserdämpfer (4) abnehmbar über dem Eisbereiter (2) angeordnet ist und dass der Wasserdämpfer (4) aus einem elastischen Material hergestellt ist und dass der Wasserdämpfer (4) entlang der vertikalen Richtung zusammenklappbar und umkehrbar ist und nach der Umkehrung über dem Eisbereiter (2) angeordnet werden kann, wobei die Richtung der Spirale in eine zweite Richtung entgegengesetzt zur ersten Richtung geändert wird.
5. Ein Kühlgerät (1), wie in einem der vorherigen Ansprüchen aufgeführt, **ist dadurch gekennzeichnet, dass** ein Heizer (8) um das Rohr (3) gewickelt wird.
6. Ein Kühlgerät (1), wie in einem der Ansprüche 2 bis 5 aufgeführt, **ist dadurch gekennzeichnet, dass** das Rohr (3) einen Auslass (9) aufweist, über den das Rohr (3) durch die Öffnung (7) gesteckt wird und wobei der Auslass (9) gegenüber einer Erstreckungsrichtung des Rohrs (3) abwinkelbar ausgebildet ist.
7. Ein Kühlgerät (1), wie in Anspruch 6 aufgeführt, **ist dadurch gekennzeichnet, dass** der Auslass (9) eine Engstelle aufweist.

Revendications

1. Un appareil de refroidissement (1) comprenant ;

une machine à glaçons (2) configurée pour produire des glaçons,
 un tuyau (3) pour alimenter en eau la machine à glaçons (2),
 un clapet d'eau (4) placé au-dessus de la machine à glaçons (2) pour recevoir l'eau du tuyau (3) et dans lequel le clapet d'eau (4) a une forme conique avec un diamètre diminuant progressivement du haut vers le bas,
caractérisé par
 un guide (5) sous la forme d'une protubérance formant une spirale dans une première direction s'étendant dans la direction verticale sur la surface intérieure de l'amortisseur d'eau (4) guidant l'écoulement de l'eau au moins partiellement le long d'elle-même.

2. Un appareil de refroidissement (1) selon la déclaration 1, **caractérisé par** un couvercle (6) placé de manière amovible sur l'amortisseur à eau (4), dans lequel le couvercle (6) comprend une ouverture (7) prévue sur celui-ci à travers laquelle le tuyau (3) est logé.

3. Appareil de refroidissement (1) selon la déclaration

2, **caractérisé en ce que** la surface de l'ouverture (7) est sensiblement inférieure à la surface du couvercle (6).

4. Un appareil de refroidissement (1) selon l'une quelconque des déclarations précédentes, **caractérisé en ce que** l'amortisseur d'eau (4) est placé de manière amovible au-dessus de la machine à glaçons (2) et **en ce que** l'amortisseur d'eau (4) est constitué d'un matériau élastique et **en ce que** l'amortisseur d'eau (4) est pliable et réversible le long de la direction verticale qui, après avoir été inversée, peut être placée au-dessus de la machine à glaçons (2) en changeant la direction de la spirale en une seconde direction opposée à la première direction.
5. Un appareil de refroidissement (1) selon l'une quelconque des déclarations précédentes, **caractérisé par** un élément chauffant (8) s'enroulant autour du tuyau (3).
6. Un appareil de refroidissement (1) selon les déclarations 2 à 5, **caractérisé en ce que** le tuyau (3) comprend une sortie (9) par laquelle le tuyau (3) est mis en place à travers l'ouverture (7) et dans lequel la sortie (9) est configurée pour se plier par rapport à une direction d'extension du tuyau (3).
7. Un appareil de refroidissement (1) selon la déclaration 6, **caractérisé en ce que** la sortie (9) comprend un goulot d'étranglement.

Figure 1

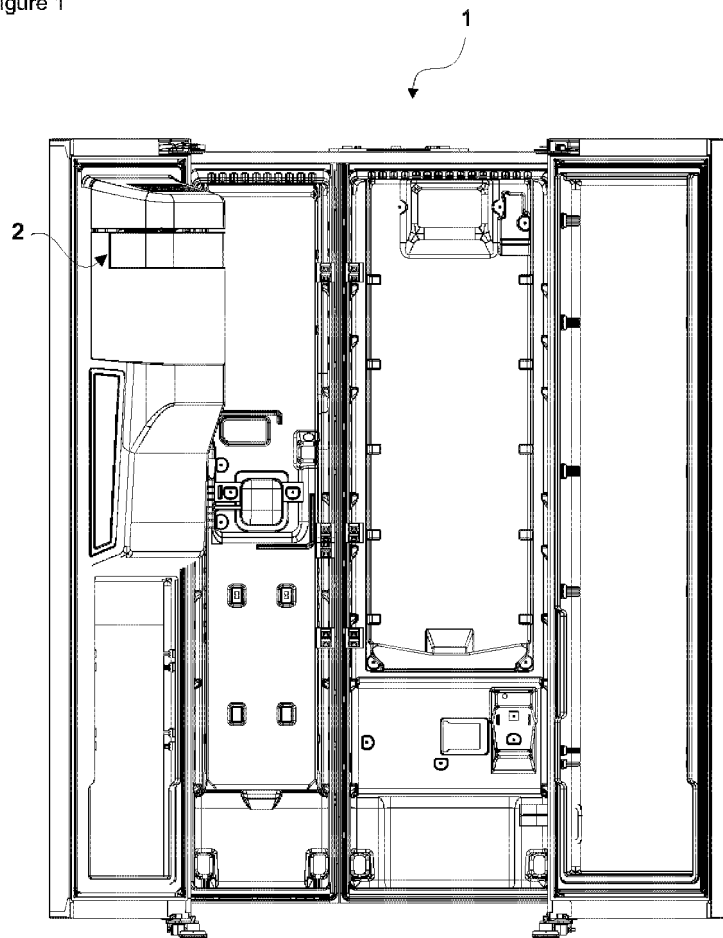

Figure 2

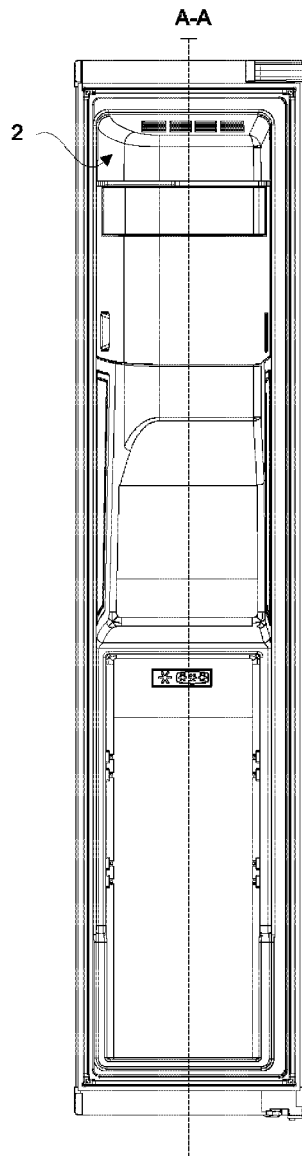

Figure 3

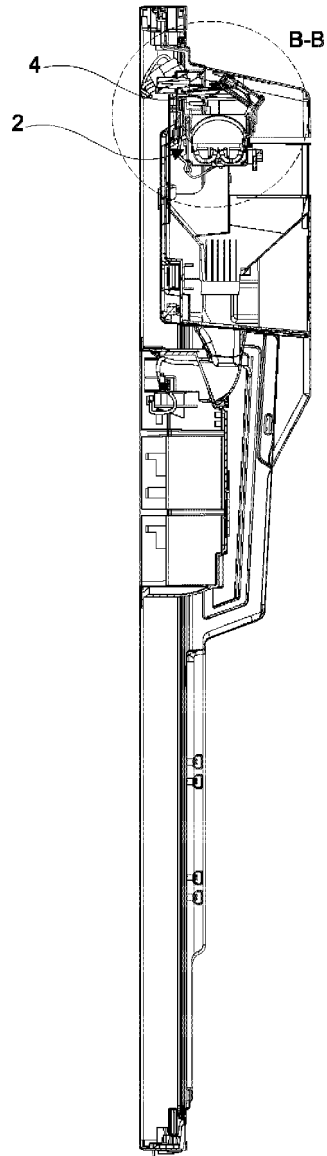

Figure 4

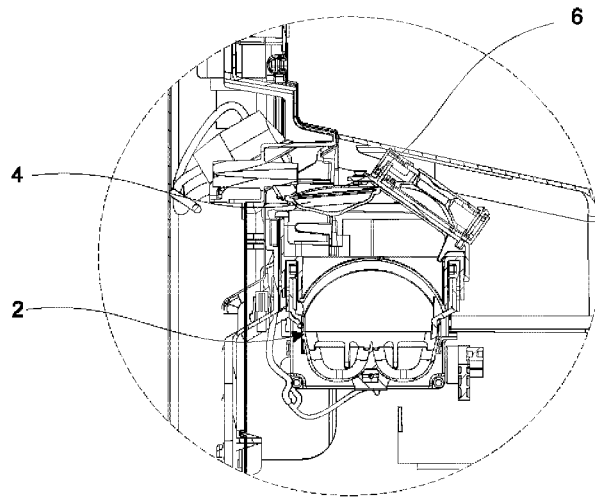
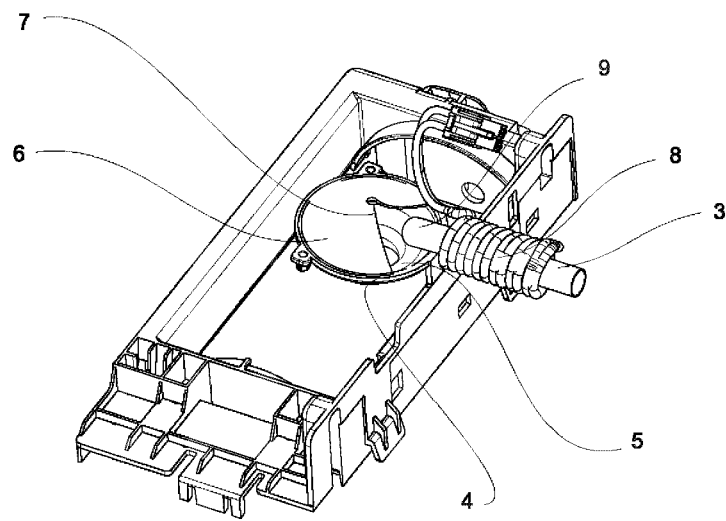

Figure 5



REFERENCES CITED IN THE DESCRIPTION

This list of references cited by the applicant is for the reader's convenience only. It does not form part of the European patent document. Even though great care has been taken in compiling the references, errors or omissions cannot be excluded and the EPO disclaims all liability in this regard.

Patent documents cited in the description

- US 2019128595 A1 [0003]
- WO 2014084506 A1 [0004]
- US 8800315 B2 [0005]