

(19)



(11)

EP 3 896 213 B1

(12)

EUROPEAN PATENT SPECIFICATION

(45) Date of publication and mention of the grant of the patent:
15.01.2025 Bulletin 2025/03

(51) International Patent Classification (IPC):
D06F 58/20 ^(2006.01) **D06F 39/04** ^(2006.01)
F28F 1/32 ^(2006.01) **F28D 1/047** ^(2006.01)
D06F 39/00 ^(2024.01) **F28F 21/08** ^(2006.01)

(21) Application number: **20169725.7**

(52) Cooperative Patent Classification (CPC):
D06F 58/206; D06F 39/04; F28D 1/0477; F28F 1/32

(22) Date of filing: **15.04.2020**

(54) **A LAUNDRY TREATING APPLIANCE HAVING A HEAT PUMP SYSTEM**

WÄSCHEBEHANDLUNGSGERÄT MIT WÄRMEPUMPENSYSTEM

APPAREIL DE TRAITEMENT DU LINGE COMPRENANT UN SYSTÈME DE POMPE À CHALEUR

(84) Designated Contracting States:
**AL AT BE BG CH CY CZ DE DK EE ES FI FR GB
 GR HR HU IE IS IT LI LT LU LV MC MK MT NL NO
 PL PT RO RS SE SI SK SM TR**

(74) Representative: **Electrolux Group Patents**
AB Electrolux
Group Patents
S:t Göransgatan 143
105 45 Stockholm (SE)

(43) Date of publication of application:
20.10.2021 Bulletin 2021/42

(56) References cited:
EP-A1- 3 066 406 EP-A1- 3 279 393
DE-A1- 102015 120 487

(73) Proprietor: **ELECTROLUX APPLIANCES**
AKTIEBOLAG
105 45 Stockholm (SE)

- **DOMANSKI P A ET AL: "Performance of a finned-tube evaporator optimized for different refrigerants and its effect on system efficiency", INTERNATIONAL JOURNAL OF REFRIGERATION, ELSEVIER, AMSTERDAM, NL, vol. 28, no. 6, 1 September 2005 (2005-09-01), pages 820 - 827, XP004998949, ISSN: 0140-7007, DOI: 10.1016/J.IJREFRIG.2005.02.003**

(72) Inventors:
 • **CAVARRETTA, Francesco**
33080 Porcia (IT)
 • **GAMBARRO, Fabio**
33080 Porcia (IT)
 • **GOBBO, Gianni**
33080 Porcia (IT)

EP 3 896 213 B1

Note: Within nine months of the publication of the mention of the grant of the European patent in the European Patent Bulletin, any person may give notice to the European Patent Office of opposition to that patent, in accordance with the Implementing Regulations. Notice of opposition shall not be deemed to have been filed until the opposition fee has been paid. (Art. 99(1) European Patent Convention).

Description

[0001] The present invention refers to a laundry treating appliance, for example a laundry washing machine (called also washing machine), a laundry washer-drier (called also washer-drier), a tumble drier, having a heat pump system.

[0002] Traditional laundry treating appliances, for example washing machines, washer-driers, tumble driers, typically comprise a cabinet containing a rotatable drum wherein the laundry to be treated (i.e. washed and/or dried) can be loaded.

[0003] An operating fluid (e.g., depending on the kind of laundry treating appliance and on the treating process to be applied, water, water mixed with a washing/rinsing additive, air), is circulated through the drum by a circulating system (comprising, for example pumps, valves, fans, etc., depending on the kind of fluid to be circulated).

[0004] In some known laundry treating appliances, the operating fluid is heated and/or cooled/dehumidified by a heat pump system, typically comprising a compressor, an expansion valve, two heat exchangers (one operating as a condenser, and the other as an evaporator), and conduits fluidly connecting such elements in a closed circuit.

[0005] A heat pump system has an improved energy efficiency with respect to traditional heating systems using an electrical heater as heat source.

[0006] Some refrigerant flows through the compressor, the condenser, the expansion valve and the evaporator, and through the conduits connecting these to one another.

[0007] The refrigerant releases heat to the operating fluid by means of the condenser, and extracts heat and humidity from the operating fluid by means of the evaporator. The compressor converts electromechanical power to thermal power by compressing the refrigerant in the refrigerant circuit. Currently, the refrigerants mainly used in heat pump systems of known laundry treating appliances are hydrofluorocarbon (HFC) refrigerants, in particular the ones known as R134a and R407C. Unfortunately, these refrigerants have a high Global Warming Potential (GWP), so alternative refrigerants start to be more and more used in different industries.

[0008] Possible alternative refrigerants used for replacing hydrofluorocarbon (HFC) refrigerants in heat pump systems of laundry treating appliances are hydrocarbons refrigerants, such as propane (R290) and propylene (R1270).

[0009] These alternative refrigerants have a negligible impact on GWP and their thermo-physical properties makes them very suitable for the typical working conditions of heat pump systems of laundry treating appliances, in particular tumble driers and washer-driers.

[0010] The downside of these alternative refrigerants is that they are flammable, and therefore, for limiting possible risks, regulations (e.g. the IEC 60335-2-11 standard) limit the amount of refrigerant that can be charged in the heat pump system to 150 g (grams).

[0011] Inside the heat pump system, when the compressor is switched ON, most of the refrigerant can be found inside the condenser, since in this heat exchanger the refrigerant is at high pressure and, for a portion thereof, in liquid state, so with a very high density.

[0012] The evaporator, on the contrary, works at low pressure, and the refrigerant contained therein is mainly a liquid-vapour mixture and a superheated vapour, so its density is quite low. It has been observed that limiting to 150 g the refrigerant charge could negatively affect the performances of the heat pump system, in particular its energy efficiency.

[0013] There is the need, therefore, to reduce the volume of the components of the heat exchangers wherein the refrigerant flows, so as to limit the refrigerant charge required by the system. On the other hand, it's important not reducing too much the external surface area, so as to keep a good heat exchange performance.

[0014] A known kind of heat exchanger, widely used in heat pump systems of laundry treating appliances, comprises a plurality of fins, typically made of aluminum and having a rectangular plane, stacked in spaced and parallel planes; the fins comprise a plurality of through-holes wherein a plurality straight pipes, made of copper or aluminum, parallel one another and perpendicular to the fins, are fitted, with their lateral surface into close contact with the border of the through-holes, so as to obtain an effective heat-exchange.

[0015] The straight pipes are connected in twos, at one end, by a curved pipe, to define as a whole a single duct wherein the refrigerant flows; this single duct has an inlet portion and an outlet portion protruding from the stack of fins, and connectable to the rest of the heat pump system circuit. During the functioning of the heat pump system, the operating fluid flows through the gaps between the fins, exchanging heat with the latter, and therefore with the refrigerant flowing in the pipes, which are thermally connected to the fins.

[0016] The fins used for producing such heat exchangers are typically produced and sold with standardized dimensions, and with a fixed number of through-holes; the producers of laundry treating appliances using such a kind of heat exchangers, in order to keep reduced the production costs, typically purchase the available fins having external dimensions (i.e. length and width) suitable for their appliances, stack them in spaced and parallel planes, and insert in all the through-holes the same number of straight pipes; typically the pipes are fastened to the through-holes by radially expanding such pipes by suitable tools. Then, the straight pipes are connected in twos, at one end, by a curved pipe, to define as a whole the single duct wherein the refrigerant flows.

[0017] Since the external dimensions of the fins and the number of through-holes is fixed, the freedom of design is very small. In particular, in order to reduce the overall volume of the single duct wherein the refrigerant flows, there is the possibility to reduce the number of stacked fins, and therefore the length of the straight

pipes composing the single duct; unfortunately, reducing the number of fins reduces also the overall thermal exchange surface of the heat exchanger, which reduces the energy efficiency of the heat pump system.

[0018] DE102015120487 discloses a heat exchanger, in particular for a heat pump dryer, having at least one tube bent in a meandering shape for the passage of a first medium to be cooled or heated; between the tube there are lamellar layers for the passage of a second medium to be heated or cooled, wherein the layers are connected to one another via layer connecting pieces; recesses are provided, in which partial cross-sections of the respective tube sections of the tube are accommodated. EP3066406A1 discloses a heat pump designed for a household appliance, in particular laundry treatment appliance, comprising a rotary compressor, a condenser, a restrictor, and an evaporator, wherein the condenser is of an expanded tube- and-fin type with the tubes having an outer diameter of less than 7 mm and wherein the roller has a height-to-radius ratio of 1.4 to 1.2.

[0019] EP3279393A1 discloses a clothes treatment apparatus, including a drum rotatably provided within a cabinet to accommodate washing and drying objects; and a heat pump including an evaporator, a compressor, a condenser, and an expansion valve, through which refrigerant is circulated, to provide heat to air discharged from the drum and circulated to the drum, wherein the heat pump further includes an internal heat exchanger configured to exchange heat between refrigerant discharged from the condenser and refrigerant passing through the evaporator.

[0020] The aim of the present invention is therefore obtaining a laundry treating appliance using a heat pump system, having a reduced Global Warming Potential (GWP) and an improved efficiency, and at the same time keeping reduced the production costs.

[0021] Within this aim, a further object of the invention is obtaining a laundry treating appliance fulfilling the safety regulations related to the refrigerant of the heat pump system, without reducing the overall energy efficiency, and and at the same time keeping reduced the production costs. Applicant has found that, by leaving empty (i.e. not inserting pipes therein) two or more through-holes of the fins of a heat exchanger of the heat pump system, it is possible reducing the overall internal volume of the single duct of the heat exchanger wherein the refrigerant flows without reducing the length of the single pipes composing such a single duct nor the number of fins, and therefore without reducing the overall thermal exchange surface, also using standard fins available in the market having a prefixed number of through-holes, and so without using customized fins which could increase the production costs.

[0022] This inventive solution allows using in the heat pump system a flammable refrigerant, like for example propane (R290) or propylene (R1270), which have a very low Global Warming Potential (GWP), but that needs to be used in small quantities, and therefore requires a

reduced volume of the single duct of the heat exchanger wherein the refrigerant flows.

[0023] In particular, above aim is solved by a laundry treating appliance comprising:

- a cabinet;
- a drum, rotatably housed within the cabinet, in which laundry can be loaded;
- a heat pump system, using one or more flammable refrigerants, configured for exchanging heat with an operating fluid;
- a circulating system configured for circulating the operating fluid through the drum;

wherein the heat pump system comprises a heat exchanger comprising:

- a plurality of metallic pipes wherein the flammable refrigerant flows;
- a plurality of fins, stacked spaced and parallel to one another, each provided with four or more substantially circular through-holes suitable for housing one of the metallic pipes and having a closed perimeter,

wherein the straight pipes are radially expanded so as to fit with their lateral surface into close contact with the border of the respective through-hole, in such a way to obtain an effective heat-exchange between them,

wherein each of at least two through-holes of the four or more through-holes of each one of the fins houses one of the metallic pipes,

wherein the metallic pipes comprise two or more straight pipes, parallel one another and perpendicular to the fins, each one of the two or more straight pipes being housed in one of the four or more through-holes of the fins, the two or more straight pipes being connected in twos, at one end, by a curved pipe, to define as a whole a single duct wherein the flammable refrigerant flows,

wherein at least two through-holes of the four or more through-holes of each one of the fins do not house any of the metallic pipes (or, in other words, they are not crossed by any metallic pipe, or are free, or empty, from metallic pipes).

[0024] Advantageously, the four or more through-holes of any fin of the plurality of fins are respectively aligned with the four or more through-holes of the rest of the plurality of fins.

[0025] In an advantageous embodiment, the stacked fins comprise perimeter edges defining as a whole an envelope surface (i.e. a surface that is tangent to the perimeter edges of all the stacked fins) comprising at least a plane portion, and wherein the four or more through-holes of each of the fins are positioned on the respective fin to define at least one first row perpendicular

to the plane portion, or to define at least one first row perpendicular to the plane portion and at least one second row perpendicular to the first row.

[0026] In a preferred embodiment, the stacked fins comprise perimeter edges defining as a whole an envelope surface comprising at least a plane portion, and wherein the four or more through-holes of each of the fins are positioned on the respective fin to define at least one first row perpendicular to the plane portion and at least one second row perpendicular to the first row, and wherein the at least two through-holes of the four or more through-holes not housing any of the metallic pipes belong to a same second row.

[0027] More preferably, in the same second row, between at least two through-holes not housing any of the metallic pipes there is at least one of the through-holes housing one of the metallic pipes; this advantageous embodiment ensures that the distribution of the metallic pipes with respect to the fins is quite uniform, and therefore that the heat distribution within the heat exchanger is quite uniform.

[0028] In a further advantageous embodiment, at least two through-holes of the four or more through-holes not housing any of the metallic pipes belong to a same first row.

[0029] Preferably, in this case in this same first row, between the at least two through-holes not housing any of the metallic pipes there is at least one of the through-holes housing one of the metallic pipes; also this advantageous embodiment ensures that the distribution of the metallic pipes with respect to the fins is quite uniform, and therefore that the heat distribution within the heat exchanger is quite uniform. In a further advantageous embodiment, the four or more through-holes of each of the fins are positioned on the respective fin to define at least one first row perpendicular to the plane portion and at least one second row perpendicular to the first row, and the fins comprise at least two second rows, and at least two through-holes of the four or more through-holes not housing any of the metallic pipes belong to two contiguous second rows.

[0030] In a further advantageous embodiment, the four or more through-holes of each of the fins are positioned on the respective fin to define at least one first row perpendicular to the plane portion, wherein the fins comprise at least two perpendicular rows, and at least two through-holes of the four or more through-holes not housing any of the metallic pipes belong to two contiguous perpendicular rows.

[0031] It is underlined that stating that two rows are contiguous means that there aren't other rows positioned between such two rows.

[0032] In another advantageous embodiment, the four or more through-holes of each of the fins are positioned on the respective fin to define at least one first row perpendicular to the plane portion, and wherein all the through-holes of the at least one first row do not house any of the metallic pipes.

[0033] In a further advantageous embodiment, the four or more through-holes of each of the fins are positioned on the respective fin to define at least one first row perpendicular to the plane portion and at least one second row perpendicular to the first row, and wherein all the through-holes of the at least one first row and/or of the at least one second row do not house any of the metallic pipes.

[0034] Further preferably, the single duct comprises an inlet portion and an outlet portion configured for allowing said flammable refrigerant respectively to enter/exit said single duct.

[0035] More preferably, the inlet portion and the outlet portion protrude both from a same terminal fin of the plurality of fins.

[0036] Preferably, the flammable refrigerant is or comprises a hydrocarbon.

[0037] More preferably, the flammable refrigerant is or comprises propane (R290) or propylene (R1270).

[0038] In a preferred embodiment, the fins are made of metal.

[0039] More preferably, the fins and/or the metallic pipes are made of, or comprise, aluminum or aluminum alloy, or copper, or copper alloy.

[0040] In an advantageous embodiment, the laundry treating appliance is a tumble drier or washer-drier, and the operating fluid is air.

[0041] In another advantageous embodiment, the laundry treating appliance is a laundry washing machine, and the operating fluid is water, or water mixed with a washing/rinsing agent. Other advantages and features of a laundry treating appliance according to the present invention will be clear from the following detailed description, provided only as a not limitative example, in which:

Fig 1 is a schematic lateral cross section of a laundry treating appliance, in particular a tumble drier, according to the invention;

Fig. 2 is a perspective view of a first embodiment of heat exchanger of a laundry treating appliance according to the invention;

Fig. 3 is a schematic plan view of a fin of a laundry treating appliance according to the invention;

Fig. 4 is a lateral view of the heat exchanger of Fig.2;

Fig. 5 is a plan view of the heat exchanger of Fig.2;

Fig. 6 is a frontal view of the heat exchanger of Fig.2;

Fig. 7 is a rear view of the heat exchanger of Fig.2;

Fig. 8 is a perspective view of a second embodiment of heat exchanger of a laundry treating appliance according to the invention;

Fig. 9 is a lateral view of the heat exchanger of Fig.8;

Fig. 10 is a plan view of the heat exchanger of Fig.8;

Fig. 11 is a frontal view of the heat exchanger of Fig.8;

Fig. 12 is a rear view of the heat exchanger of Fig.8;

Fig. 13 is a perspective view of a second embodiment of heat exchanger of a laundry treating appliance according to the invention;

Fig. 14 is a lateral view of the heat exchanger of

Fig. 13;
 Fig. 15 is a plan view of the heat exchanger of Fig. 13;
 Fig. 16 is a frontal view of the heat exchanger of Fig. 13;
 Fig. 17 is a rear view of the heat exchanger of Fig. 13
 Fig. 18 is a lateral schematic view of the stacked fins of an heat exchanger according to the invention;
 Fig. 19 is a schematic view of four through-holes of a fin of a heat exchanger according to the invention.

[0042] In the figures, same parts are indicated with the same reference numbers.

[0043] Advantageously, the laundry treating appliance 10 illustrated in figure 1 is a tumble drier of the "horizontal axis type"; it is however clear that the invention can be applied, without any substantial modification, also to tumble driers of the vertical axis" type, and to washing machines and washer driers, both of the "horizontal axis" and of the "vertical axis" type.

[0044] The laundry treating appliance (being it a tumble drier 10, or a washing machine or washer-drier, not illustrated) comprises a cabinet 20, or housing, preferably parallelepiped, configured to be positioned on a horizontal surface 2, for example the floor of a building, preferably by suitable feet 21, one or more of which can have, advantageously, an adjustable height, so as to adapt to a possible not perfect planarity of the horizontal surface 2.

[0045] Advantageously, in the frontal wall 20a of the cabinet 20 an access opening, not illustrated, is preferably obtained, advantageously selectively closable by a loading/unloading door 4, preferably hinged to the frontal wall 20a.

[0046] The laundry treating appliance (being it a tumble drier 10, or a washing machine or washer-drier) comprises a drum 30 rotatably housed within the cabinet 20, in which the laundry, not illustrated, can be loaded.

[0047] If the laundry treating appliance is a washing machine or a washer-drier, both not illustrated, the cabinet 20 also houses a washing tub, not illustrated, preferably suspended to the cabinet through springs and dumpers, also not illustrated, in which the drum 30 is rotatably contained.

[0048] The laundry treating appliance 10 comprises a circulating system 60 configured for circulating an operating fluid through the drum 3.

[0049] It is underlined that the circulating system 60 can define a closed circuit for the operating fluid (i.e. the operating fluid remains within the closed circuit during the laundry treating process, and the same fluid, opportunely treated, passed repeatedly through the drum 30), or it can define an opened circuit for the operating fluid (i.e. the operating fluid is loaded within the laundry treating appliance 10 at a certain point of the laundry treating process, and it is drained from the laundry treating appliance 10 at another point of the laundry treating process).

[0050] In the advantageous embodiment in which the laundry treating appliance 10 is a tumble drier, like the

advantageous example of figure 1, or a washer drier, not illustrated, the operating fluid is or comprises air (represented by arrows 50), and the circulating system preferably comprises an air circuit 61 and one or more fans 62 configured for circulating such air 50 through the drum 3 and the air circuit 61.

[0051] If the laundry treating appliance is a tumble drier 10, it can also advantageously comprise a lint filter 63, arranged in the air circuit 61 for trapping lint or fluff released from the laundry.

[0052] If the laundry treating appliance is a washing machine or a washer drier, both not illustrated, the operating fluid is or comprises water, or water mixed with a washing/rinsing additive, and the circulating system preferably comprises a water inlet circuit, not illustrated, adapted to feed water into the tub, also not illustrated, and a drain circuit, also not illustrated, adapted for draining washing/rinsing liquid from the machine.

[0053] The laundry treating appliance 10 advantageously comprises a heat pump system 40, configured for heating the operating fluid, for example, in case of a tumble drier, the air 50. Advantageously, the heat pump system 40 can also be configured for cooling and dehumidifying the operating fluid.

[0054] Preferably, the heat pump system 40 comprises a compressor, not illustrated, an expansion valve, also not illustrated, two heat exchangers 70a, 70b (one operating as a condenser, and the other as an evaporator), and conduits, not illustrated, fluidly connecting such elements in a closed circuit.

[0055] A flammable refrigerant flows through the compressor, the condenser 70a, the expansion valve and the evaporator 70b, and through the conduits connecting these to one another.

[0056] The flammable refrigerant releases heat to the operating fluid by means of the condenser 70a and extracts heat and humidity from the operating fluid by means of the evaporator 70b. The compressor converts electromechanical power to thermal power by compressing the flammable refrigerant in the refrigerant circuit.

[0057] The flammable refrigerant is or comprises a hydrocarbon, preferably propane (R290) or propylene (R1270). Advantageously, the heat exchangers, for example the condenser 70a and/or the evaporator 70b, comprise a plurality of metallic pipes 80 (called also simply pipes) wherein the flammable refrigerant flows, and a plurality of fins 90 (advantageously metallic), stacked spaced and parallel to one another, each provided with four or more through-holes 100 suitable for housing one of the metallic pipes 80. Advantageously, the through-holes 100 of any fin 90 are respectively aligned with the through-holes 100 of the rest of the fins 90.

[0058] Advantageously, the perimeter edges 99 of the stacked fins 90 define as a whole an envelope surface, illustrated in figures and 18 with a dotted line numbered 92, comprising at least a plane portion 93.

[0059] Preferably, the fins 90 have a rectangular or square plan, in which case the envelope surface 92

comprises four plane portions, corresponding to the four sides of the rectangle or square.

[0060] Preferably, the width of the fins 90 is comprised between 65 mm and 145 mm, more preferably between 95 mm and 125 mm. Preferably, the height of the fins 90 is comprised between 110 mm and 185 mm, more preferably between 145 mm and 165 mm. Preferably, the overall length of the stacked fins 90 is comprised between 330 mm and 370 mm, more preferably between 200 mm and 250 mm.

[0061] Advantageously, the fins 90 are made of, or comprise, aluminum or aluminum alloy, or copper, or copper alloy.

[0062] Advantageously, the more metallic pipes 80 are made of, or comprise, aluminum or aluminum alloy, or copper or copper alloy.

[0063] The metallic pipes 80 comprise two or more straight pipes 81, parallel one another and perpendicular to the fins 90, each one of the two or more straight pipes 81 being housed in one of the through-holes 100 of the fins 90.

[0064] The straight pipes 81 are fitted, with their lateral surface into close contact with the border of the respective through-holes 100, so as to obtain an effective heat-exchange between them; this can be obtained by radially expanding such straight pipes 81 by suitable tools, not illustrated.

[0065] The two or more straight pipes 81 are connected in twos, at one end thereof, by a curved pipe 82, to define as a whole a single duct 83 wherein the flammable refrigerant flows.

[0066] Such a single duct 83 advantageously comprises an inlet portion 831 and an outlet portion 832, configured for allowing the flammable refrigerant respectively to enter/exit the single duct; advantageously, the inlet portion 831 and the outlet portion 832 are fluidly connected or connectable to the other elements of the heat pump system 40, so as to allow circulation of the flammable refrigerant through the respective heat exchanger 70a or 70b.

[0067] Advantageously, like in the examples of attached figures, the inlet portion 831 and an outlet portion 832 protrude both from a same terminal fin 91 of the plurality of fins 90, which simplifies the connection of the single duct 83 to the other conduits of the heat pump system 40.

[0068] Advantageously, at least two through-holes 101 of the four or more through-holes 100 of each fin 90 houses one of the metallic pipes 80.

[0069] Advantageously, at least two through-holes 102 of the four or more through-holes 100 of each fin 90 do not house any of the metallic pipes 80 (or in other words they are not crossed by any metallic pipe 80, or are free, or empty, from metallic pipes 80).

[0070] In this way, the number of metallic pipes 80, and therefore the overall internal volume of the single duct 83 composed of such metallic pipes 80, wherein the flammable refrigerant flows, is reduced, while the number of

fins 90, and therefore the overall length of their stack, can be relatively high, so as to obtain a desired overall thermal exchange surface.

[0071] In an advantageous embodiment, four or more through-holes 100 of each fin 90 are positioned on the respective fin 90 to define at least one first row 160 perpendicular to the plane portion 93 of the envelope surface 92 and/or at least one second row 150 perpendicular to the first rows 160.

[0072] For example, in case four through-holes 10, they can be all aligned along to a single first row 160, or they can be all aligned along a single second row 150, or they can be positioned, as illustrated for example in figure 19, each at a vertex of a rectangle or square, so as to define, as a whole, two first rows 160 and two second rows 150.

[0073] In advantageous embodiments, like for example the ones illustrated in figures 6, 11 and 16, at least two through-holes of the four or more through-holes 100 not housing any of the pipes 80 belong to a same second row 150.

[0074] In an advantageous embodiment, like for example the one illustrated in figure 6, in a same second row 150, between at least two through-holes 102 not housing any metallic pipes 80 there is at least one through-hole 101 housing one metallic pipes 80.

[0075] In advantageous embodiments, like for example the one illustrated in figure 6, at least two through-holes 102 of the four or more through-holes 100 not housing any metallic pipe 80 belong to a same first row 160.

[0076] In a preferred embodiment, like for example the one illustrated in figure 6, in a same first row 160, between two through-holes 102 not housing any metallic pipes 80 there is at least one through-hole 101 housing one metallic pipe 80. Preferably, the fins 90 comprise at least two second rows 150, and, like for example in the advantageous embodiments of figures 6 and 11, at least two through-holes 102 not housing any metallic pipe 80 belong to two contiguous second rows 150. In a further advantageous embodiment, the fins 90 comprise at least two of first rows 160, and, like for example in the advantageous embodiments of figure 11 and 16, at least two through-holes 102 not housing any metallic pipe 80 belong to two contiguous first rows 160.

[0077] In a further advantageous embodiment, not illustrated, all the through-holes 100 of a first row 160 and/or of one second row 150 do not house any of metallic pipe 80.

[0078] Anyway, different positionings of the at least two through-holes 102 are possible.

[0079] It is seen therefore how the invention achieves the proposed aim and objects, since it allows obtaining, using commercially available fins (which have prefixed dimensions and numbers of through-holes), an evaporator for the heat pump system of a laundry treating appliance having a relatively small volume of the single duct wherein the refrigerant flows, and a high overall thermal

exchange surface; this evaporator, which production costs are therefore kept reduced (since it does not use customized fins), allows using in the heat pump system a flammable refrigerant, like for example propane (R290) or propylene (R1270), which have a very low Global Warming Potential (GWP), fulfilling the regulation requirements related to flammable refrigerant charge, and keeping at the same time a high energetic efficiency.

Claims

1. A laundry treating appliance (10) comprising:

- a cabinet (20);
 - a drum (30), rotatably housed within said cabinet (20), in which laundry can be loaded;
 - a heat pump system (40), using one or more flammable refrigerants, configured for exchanging heat with an operating fluid (50);
 - a circulating system (60) configured for circulating said operating fluid (50) through said drum (30);
- wherein said heat pump system (40) comprises a heat exchanger (70a, 70b) comprising:

- a plurality of metallic pipes (80) wherein said flammable refrigerant flows;
- a plurality of fins (90), stacked, spaced and parallel to one another, each provided with four or more substantially circular through-holes (100) suitable for housing one of said metallic pipes (80) and having a closed perimeter,

wherein said straight pipes (81) are radially expanded so as to fit with their lateral surface into close contact with the border of said respective through-hole (100), in such a way to obtain an effective heat-exchange between them, wherein each of at least two through-holes (101) of said four or more through-holes (100) of each one of said fins (90) houses one of said metallic pipes (80), wherein said metallic pipes (80) comprise two or more straight pipes (81), parallel one another and perpendicular to said fins (90), each one of said two or more straight pipes (81) being housed in one of said four or more through-holes (100) of said fins (90), said two or more straight pipes (81) being connected in twos, at one end, by a curved pipe (82), to define as a whole a single duct (83) wherein said flammable refrigerant flows,

characterized in that

at least two through-holes (102) of said four or more through-holes (100) of each one of said fins (90) do not house any of said metallic pipes

(80).

2. A laundry treating appliance (10) according to claim 1, wherein said stacked fins (90) comprise perimeter edges (99) defining as a whole an envelope surface (92) comprising at least a plane portion (93), and wherein said four or more through-holes (100) of each of said fins (90) are positioned on the respective fin (90) to define at least one first row (160) perpendicular to said plane portion (93), or to define at least one first row (160) perpendicular to said plane portion (93) and at least one second row (150) perpendicular to said first row (160).

3. A laundry treating appliance (10) according to claim 1, wherein said stacked fins (90) comprise perimeter edges (99) defining as a whole an envelope surface (92) comprising at least a plane portion (93), and wherein said four or more through-holes (100) of each of said fins (90) are positioned on the respective fin (90) to define at least one first row (160) perpendicular to said plane portion (93) and at least one second row (150) perpendicular to said first row (160), and wherein at least two through-holes (102) of said four or more through-holes (100) not housing any of said metallic pipes (80) belong to a same second row (150).

4. A laundry treating appliance (10) according to claim 3, wherein in said same second row (150), between said at least two through-holes (102) not housing any of said metallic pipes (80) there is at least one of said through-holes (101) housing one of said metallic pipes (80).

5. A laundry treating appliance (10) according to claim 2 or 3 or 4, wherein at least two through-holes (102) of said four or more through-holes (100) not housing any of said metallic pipes (80) belong to a same first row (160).

6. A laundry treating appliance (10) according to claim 5, wherein in said same first row (160), between said at least two through-holes (102) not housing any of said metallic pipes (80) there is at least one of said through-holes (101) housing one of said metallic pipes (80).

7. A laundry treating appliance (10) according to one or more of claims 2 to 6, wherein said four or more through-holes (100) of each of said fins (90) are positioned on the respective fin (90) to define at least one first row (160) perpendicular to said plane portion (93) and at least one second row (150) perpendicular to said first row (160), and wherein said fins (90) comprise at least two of said second rows (150), and wherein at least two through-holes (102) of said four or more through-holes (100) not housing any of

said metallic pipes (80) belong to two contiguous second rows (150) .

8. A laundry treating appliance (10) according to one or more of claims 2 to 7, wherein said four or more through-holes (100) of each of said fins (90) are positioned on the respective fin (90) to define at least one first row (160) perpendicular to said plane portion (93), wherein said fins (90) comprise at least two of said first rows (160), and wherein at least two through-holes (102) of said four or more through-holes (100) not housing any of said metallic pipes (80) belong to two contiguous first rows (160). 5
9. A laundry treating appliance (10) according to claim 2, wherein said four or more through-holes (100) of each of said fins (90) are positioned on the respective fin (90) to define at least one first row (160) perpendicular to said plane portion (93), and wherein all the through-holes (100) of said at least one first row (160) do not house any of said metallic pipes (80). 10 20
10. A laundry treating appliance (10) according to claim 2, wherein said four or more through-holes (100) of each of said fins (90) are positioned on the respective fin (90) to define at least one first row (160) perpendicular to said plane portion (93) and at least one second row (150) perpendicular to said first row (160), and wherein all the through-holes (100) of said at least one first row (160) and/or of said at least one second row (150) do not house any of said metallic pipes (80). 25 30
11. A laundry treating appliance (100) according to one or more of the previous claims, wherein said single duct (83) comprises an inlet portion (831) and an outlet portion (832) configured for allowing said flammable refrigerant respectively to enter/exit said single duct (83). 35 40
12. A laundry treating appliance (100) according to claim 11, wherein said inlet portion (831) and said outlet portion (832) protrude both from a same terminal fin (91) of said plurality of fins (90). 45
13. A laundry treating appliance (10) according to one or more of the previous claims, wherein said flammable refrigerant is or comprises a hydrocarbon or is or comprises propane (R290) or propylene. 50
14. A laundry treating appliance (10) according to one or more of the previous claims, wherein said fins (90) and/or said metallic pipes (80) are made of, or comprise, aluminum or aluminum alloy, or copper, or copper alloy. 55
15. A laundry treating appliance (10) according to one or more of the previous claims, wherein said laundry

treating appliance (10) is a tumble drier (11) or a washer-drier, and said operating fluid (50) is air or wherein said laundry treating appliance (10) is a laundry washing machine, and said operating fluid (50) is water, or water mixed with a washing/rinsing agent.

Patentansprüche

1. Wäschebehandlungsgerät (10), das Folgendes umfasst:

- ein Gehäuse (20);
- eine innerhalb des Gehäuses (20) drehbar aufgenommene Trommel (30), die mit Wäsche beladen werden kann;
- ein Wärmepumpensystem (40), das ein oder mehrere zum Austauschen von Wärme mit einem Betriebsfluid (50) vorgesehene brennbare Kältemittel nutzt;
- ein Umwälzsystem (60), das zum Umwälzen des Betriebsfluids (50) durch die Trommel (30) vorgesehen ist;

wobei das Wärmepumpensystem (40) einen Wärmeaustauscher (70a, 70b) umfasst, der Folgendes umfasst:

- mehrere Metallrohre (80), in denen das brennbare Kältemittel fließt;
- mehrere übereinander angeordnete, zueinander beabstandete und zueinander parallele Rippen (90), die je mit vier oder mehr im Wesentlichen kreisförmigen Durchgangslöchern (100), die zum Aufnehmen eines der Metallrohre (80) geeignet sind und einen geschlossenen Umfang aufweisen, versehen sind,

wobei die geraden Rohre (81) radial erweitert sind, um mit ihrer seitlichen Oberfläche in einen engen Kontakt mit dem Rand des jeweiligen Durchgangslochs (100) zu passen, so dass zwischen ihnen ein effektiver Wärmeaustausch erzielt wird,

wobei jedes von mindestens zwei Durchgangslöchern (101) der vier oder mehr Durchgangslöcher (100) jeder der Rippen (90) eines der Metallrohre (80) aufnimmt,

wobei die Metallrohre (80) zwei oder mehr gerade, zueinander parallele und zu den Rippen (90) senkrechte Rohre (81) umfassen, wobei jedes der zwei oder mehr geraden Rohre (81) in einem der vier oder mehr Durchgangslöcher (100) der Rippen (90) aufgenommen ist,

wobei die zwei oder mehr geraden Rohre (81) an einem Ende durch ein gekrümmtes Rohr (82) in Paaren verbunden sind, um im Ganzen einen

- Einzelkanal (83), in dem das brennbare Kältemittel fließt, zu definieren,
dadurch gekennzeichnet, dass
 mindestens zwei Durchgangslöcher (102) der vier oder mehr Durchgangslöcher (100) jeder der Rippen (90) keine der Metallrohre (80) aufnehmen.
2. Wäschebehandlungsgerät (10) nach Anspruch 1, wobei die übereinander angeordneten Rippen (90) Umfangskanten (99) umfassen, die im Ganzen eine Hüllfläche (92), die mindestens einen Ebenenabschnitt (93) umfasst, definieren, und wobei die vier oder mehr Durchgangslöcher (100) jeder der Rippen (90) auf der jeweiligen Rippe (90) positioniert sind, um mindestens eine erste Reihe (160), die senkrecht zu dem Ebenenabschnitt (93) verläuft, zu definieren oder um mindestens eine erste Reihe (160), die senkrecht zu dem Ebenenabschnitt (93) verläuft, und mindestens eine zweite Reihe (150), die senkrecht zu der ersten Reihe (160) verläuft, zu definieren.
 3. Wäschebehandlungsgerät (10) nach Anspruch 1, wobei die übereinander angeordneten Rippen (90) Umfangskanten (99) umfassen, die im Ganzen eine Hüllfläche (92), die mindestens einen Ebenenabschnitt (93) umfasst, definieren, und wobei die vier oder mehr Durchgangslöcher (100) jeder der Rippen (90) auf der jeweiligen Rippe (90) positioniert sind, um mindestens eine erste Reihe (160), die senkrecht zu dem Ebenenabschnitt (93) verläuft, und mindestens eine zweite Reihe (150), die senkrecht zu der ersten Reihe (160) verläuft, zu definieren, und wobei mindestens zwei Durchgangslöcher (102) der vier oder mehr Durchgangslöcher (100), die keine der Metallrohre (80) aufnehmen, zu einer selben zweiten Reihe (150) gehören.
 4. Wäschebehandlungsgerät (10) nach Anspruch 3, wobei sich in derselben zweiten Reihe (150) zwischen den mindestens zwei Durchgangslöchern (102), die keine der Metallrohre (80) aufnehmen, mindestens eines der Durchgangslöcher (101), die eines der Metallrohre (80) aufnehmen, befindet.
 5. Wäschebehandlungsgerät (10) nach Anspruch 2 oder 3 oder 4, wobei mindestens zwei Durchgangslöcher (102) der vier oder mehr Durchgangslöcher (100), die keine der Metallrohre (80) aufnehmen, zu einer selben ersten Reihe (160) gehören.
 6. Wäschebehandlungsgerät (10) nach Anspruch 5, wobei sich in derselben ersten Reihe (160) zwischen den mindestens zwei Durchgangslöchern (102), die keine der Metallrohre (80) aufnehmen, mindestens eines der Durchgangslöcher (101), die eines der Metallrohre (80) aufnehmen, befindet.
 7. Wäschebehandlungsgerät (10) nach einem oder mehreren der Ansprüche 2 bis 6, wobei die vier oder mehr Durchgangslöcher (100) jeder der Rippen (90) auf der jeweiligen Rippe (90) positioniert sind, um mindestens eine erste Reihe (160), die senkrecht zu dem Ebenenabschnitt (93) verläuft, und mindestens eine zweite Reihe (150), die senkrecht zu der ersten Reihe (160) verläuft, zu definieren, und wobei die Rippen (90) mindestens zwei der zweiten Reihen (150) umfassen und wobei mindestens zwei Durchgangslöcher (102) der vier oder mehr Durchgangslöcher (100), die keine der Metallrohre (80) aufnehmen, zu zwei nebeneinanderliegenden zweiten Reihen (150) gehören.
 8. Wäschebehandlungsgerät (10) nach einem oder mehreren der Ansprüche 2 bis 7, wobei die vier oder mehr Durchgangslöcher (100) jeder der Rippen (90) auf der jeweiligen Rippe (90) positioniert sind, um mindestens eine erste Reihe (160), die senkrecht zu dem Ebenenabschnitt (93) verläuft, zu definieren, wobei die Rippen (90) mindestens zwei der ersten Reihen (160) umfassen, und wobei mindestens zwei Durchgangslöcher (102) der vier oder mehr Durchgangslöcher (100), die keine der Metallrohre (80) aufnehmen, zu zwei nebeneinanderliegenden ersten Reihen (160) gehören.
 9. Wäschebehandlungsgerät (10) nach Anspruch 2, wobei die vier oder mehr Durchgangslöcher (100) jeder der Rippen (90) auf der jeweiligen Rippe (90) positioniert sind, um mindestens eine erste Reihe (160), die senkrecht zu dem Ebenenabschnitt (93) verläuft, zu definieren, und wobei alle der Durchgangslöcher (100) der mindestens einen ersten Reihe (160) keine der Metallrohre (80) aufnehmen.
 10. Wäschebehandlungsgerät (10) nach Anspruch 2, wobei die vier oder mehr Durchgangslöcher (100) jeder der Rippen (90) auf der jeweiligen Rippe (90) positioniert sind, um mindestens eine erste Reihe (160), die senkrecht zu dem Ebenenabschnitt (93) verläuft, und mindestens eine zweite Reihe (150), die senkrecht zu der ersten Reihe (160) verläuft, zu definieren, und wobei alle der Durchgangslöcher (100) der mindestens einen ersten Reihe (160) und/oder der mindestens einen zweiten Reihe (150) keine der Metallrohre (80) aufnehmen.
 11. Wäschebehandlungsgerät (100) nach einem oder mehreren der vorhergehenden Ansprüche, wobei der Einzelkanal (83) einen Einlassabschnitt (831) und einen Auslassabschnitt (832) umfasst, die dazu vorgesehen sind, zuzulassen, dass das brennbare Kältemittel in den Einzelkanal (83) eintritt bzw. aus ihm austritt.
 12. Wäschebehandlungsgerät (100) nach Anspruch 11,

wobei sowohl der Einlassabschnitt (831) als auch der Auslassabschnitt (832) von einer selben Abschlussrippe (91) der mehreren Rippen (90) vorstehen.

13. Wäschebehandlungsgerät (10) nach einem oder mehreren der vorhergehenden Ansprüche, wobei das brennbare Kältemittel ein Kohlenwasserstoff ist oder einen Kohlenwasserstoff umfasst oder Propan (R290) oder Propylen ist oder umfasst.
14. Wäschebehandlungsgerät (10) nach einem oder mehreren der vorhergehenden Ansprüche, wobei die Rippen (90) und/oder die Metallrohre (80) aus Aluminium oder einer Aluminiumlegierung oder Kupfer oder einer Kupferlegierung hergestellt sind oder Aluminium oder eine Aluminiumlegierung oder Kupfer oder eine Kupferlegierung umfassen.
15. Wäschebehandlungsgerät (10) nach einem oder mehreren der vorhergehenden Ansprüche, wobei das Wäschebehandlungsgerät (10) ein Wäschetrockner (11) oder ein Waschautomat mit Trockner ist und das Betriebsfluid (50) Luft ist oder wobei das Wäschebehandlungsgerät (10) eine Wäschewaschmaschine ist und das Betriebsfluid (50) Wasser oder mit einem Wasch-/Spülmittel gemischtes Wasser ist.

Revendications

1. Appareil de traitement du linge (10) comprenant :

- un caisson (20) ;
 - un tambour (30), logé de manière rotative à l'intérieur dudit caisson (20), dans lequel du linge peut être chargé ;
 - un système de pompe à chaleur (40), utilisant un ou plusieurs réfrigérants inflammables, configuré pour échanger de la chaleur avec un fluide de travail (50) ;
 - un système de circulation (60) configuré pour faire circuler ledit fluide de travail (50) à travers ledit tambour (30) ;
- dans lequel ledit système de pompe à chaleur comprend un échangeur de chaleur (70a, 70b) comprenant :

- une pluralité de tuyaux métalliques (80) dans lesquels ledit réfrigérant inflammable s'écoule ;
- une pluralité d'ailettes (90), empilées, espacées et parallèles les unes aux autres, chacune pourvue de quatre ou plus trous traversants sensiblement circulaires adaptés pour abriter l'un desdits tuyaux métalliques (80) et ayant un périmètre fermé,

dans lequel lesdits tuyaux droits (81) sont étendus radialement de manière à s'ajuster avec leur surface latérale en contact étroit avec la bordure dudit trou traversant (100) respectif, de manière à obtenir un échange de chaleur efficace entre eux,

dans lequel chacun d'au moins deux trous traversants (101) desdits quatre ou plus trous traversants (100) de chacune desdites ailettes (90) abrite l'un desdits tuyaux métalliques (80), dans lequel lesdits tuyaux métalliques (80) comprennent deux ou plus tuyaux droits (81), parallèles les uns aux autres et perpendiculaires auxdites ailettes (90), chacun desdits deux ou plus tuyaux droits (81) étant abrité dans l'un desdits quatre ou plus trous traversants (100) desdites ailettes (90), lesdits deux ou plus tuyaux droits (81) étant reliés par deux, au niveau d'une extrémité, par un tuyau incurvé (82), pour définir dans son ensemble un conduit unique (83) dans lequel ledit réfrigérant inflammable s'écoule,

caractérisé en ce que

au moins deux trous traversants (102) desdits quatre ou plus trous traversants (100) de chacune desdites ailettes (90) n'abritent aucun desdits tuyaux métalliques (80).

2. Appareil de traitement du linge (10) selon la revendication 1, dans lequel lesdites ailettes empilées (90) comprennent des bords périphériques (99) définissant dans son ensemble une surface d'enveloppe (92) comprenant au moins une partie plane (93), et dans lequel lesdits quatre ou plus trous traversants (100) de chacune desdites ailettes (90) sont positionnés sur l'ailette respective (90) pour définir au moins une première rangée (160) perpendiculaire à ladite partie plane (93), ou pour définir au moins une première rangée (160) perpendiculaire à ladite partie plane (93) et au moins une deuxième rangée (150) perpendiculaire à ladite première rangée (160).

3. Appareil de traitement du linge (10) selon la revendication 1, dans lequel lesdites ailettes empilées (90) comprennent des bords périphériques (99) définissant dans son ensemble une surface d'enveloppe (92) comprenant au moins une partie plane (93), et dans lequel lesdits quatre ou plus trous traversants (100) de chacune desdites ailettes (90) sont positionnés sur l'ailette respective (90) pour définir au moins une première rangée (160) perpendiculaire à ladite partie plane (93) et au moins une deuxième rangée (150) perpendiculaire à ladite première rangée (160), et dans lequel au moins deux trous traversants (102) desdits quatre ou plus trous traversants (100) n'abritent aucun desdits tuyaux métalliques (80) appartiennent à une même deuxième

- rangée (150).
4. Appareil de traitement du linge (10) selon la revendication 3, dans lequel dans ladite même deuxième rangée (150), entre lesdits au moins deux trous traversants (102) n'abritant aucun desdits tuyaux métalliques (80), il y a au moins l'un desdits trous traversants (101) abritant l'un desdits tuyaux métalliques (80). 5
 5. Appareil de traitement du linge (10) selon la revendication 2 ou 3 ou 4, dans lequel au moins deux trous traversants (102) desdits quatre ou plus trous traversants (100) n'abritant aucun desdits tuyaux métalliques (80) appartiennent à une même première rangée (160). 10
 6. Appareil de traitement du linge (10) selon la revendication 5, dans lequel dans ladite même première rangée (160), entre lesdits au moins deux trous traversants (102) n'abritant aucun desdits tuyaux métalliques (80), il y a au moins l'un desdits trous traversants (101) abritant l'un desdits tuyaux métalliques (80). 15
 7. Appareil de traitement du linge (10) selon une ou plusieurs des revendications 2 à 6, dans lequel lesdits quatre ou plus trous traversants (100) de chacune desdites ailettes (90) sont positionnés sur l'ailette respective (90) pour définir au moins une première rangée (160) perpendiculaire à ladite partie plane (93) et au moins une deuxième rangée (150) perpendiculaire à ladite première rangée (160), et dans lequel lesdites ailettes (90) comprennent au moins deux desdites deuxièmes rangées (150), et dans lequel au moins deux trous traversants (102) desdits quatre ou plus trous traversants (100) n'abritant aucun desdits tuyaux métalliques (80) appartiennent à deux deuxièmes rangées contiguës (150). 20
 8. Appareil de traitement du linge (10) selon une ou plusieurs des revendications 2 à 7, dans lequel lesdits quatre ou plus trous traversants (100) de chacune desdites ailettes (90) sont positionnés sur l'ailette respective (90) pour définir au moins une première rangée (160) perpendiculaire à ladite partie plane (93), dans lequel lesdites ailettes (90) comprennent au moins deux desdites premières rangées (160), et dans lequel au moins deux trous traversants (102) desdits quatre ou plus trous traversants (100) n'abritant aucun desdits tuyaux métalliques (80) appartiennent à deux premières rangées contiguës (160). 25
 9. Appareil de traitement du linge (10) selon la revendication 2, dans lequel lesdits quatre ou plus trous traversants (100) de chacune desdites ailettes (90) sont positionnés sur l'ailette respective (90) pour définir au moins une première rangée (160) perpendiculaire à ladite partie plane (93), et dans lequel tous les trous traversants (100) de ladite au moins une première rangée (160) n'abritent aucun desdits tuyaux métalliques (80). 30
 10. Appareil de traitement du linge (10) selon la revendication 2, dans lequel lesdits quatre ou plus trous traversants (100) de chacune desdites ailettes (90) sont positionnés sur l'ailette respective (90) pour définir au moins une première rangée (160) perpendiculaire à ladite partie plane (93) et au moins une deuxième rangée (150) perpendiculaire à ladite première rangée (160), et dans lequel tous les trous traversants (100) de ladite au moins une première rangée (160) et/ou de ladite au moins une deuxième rangée (150) n'abritent aucun desdits tuyaux métalliques (80). 35
 11. Appareil de traitement du linge (100) selon une ou plusieurs des revendications précédentes, dans lequel ledit conduit unique (83) comprend une partie d'entrée (831) et une partie de sortie (832) configurées pour permettre audit réfrigérant inflammable respectivement d'entrer dans ledit/de sortir dudit conduit unique (83). 40
 12. Appareil de traitement du linge (100) selon la revendication 11, dans lequel ladite partie d'entrée (831) et ladite partie de sortie (832) font saillie toutes les deux à partir d'une même ailette terminale (91) de ladite pluralité d'ailettes (90). 45
 13. Appareil de traitement du linge (10) selon une ou plusieurs des revendications précédentes, dans lequel ledit réfrigérant inflammable est ou comprend un hydrocarbure ou est ou comprend du propane (R290) ou du propylène. 50
 14. Appareil de traitement du linge (10) selon une ou plusieurs des revendications précédentes, dans lequel lesdites ailettes (90) et/ou lesdits tuyaux métalliques (80) sont constitués de, ou comprennent, de l'aluminium ou un alliage d'aluminium, ou du cuivre, ou un alliage de cuivre. 55
 15. Appareil de traitement du linge (10) selon une ou plusieurs des revendications précédentes, dans lequel ledit appareil de traitement du linge (10) est un sèche-linge (11) ou un lave-linge séchant, et ledit fluide de travail (50) est de l'air ou dans lequel ledit appareil de traitement du linge (10) est un lave-linge, et ledit fluide de travail (50) est de l'eau, ou de l'eau mélangée à un agent de lavage/rinçage.

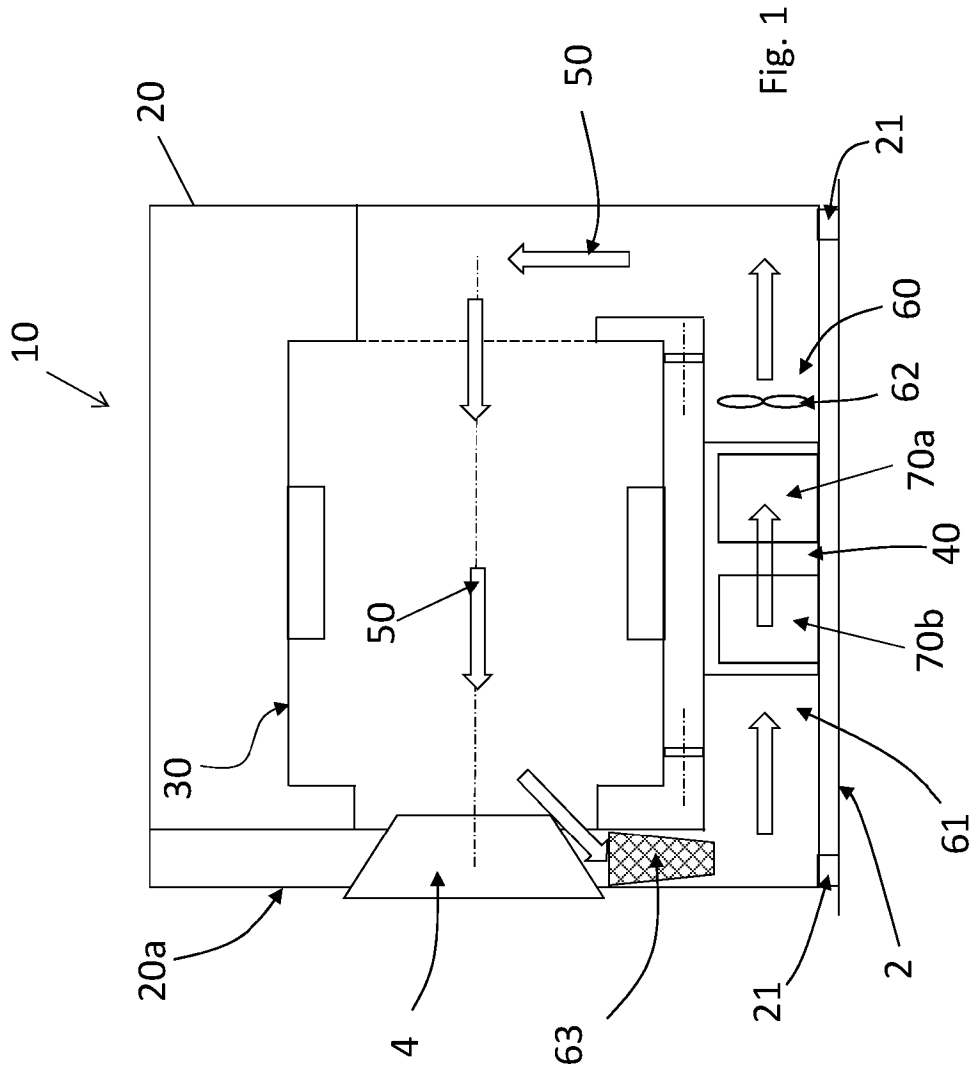

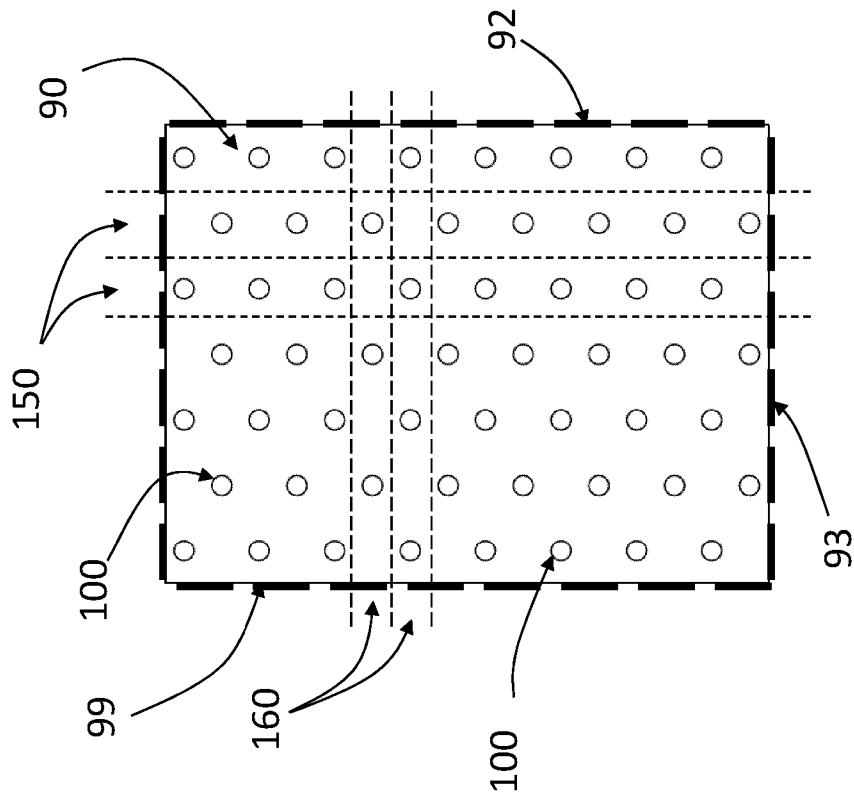

Fig. 3

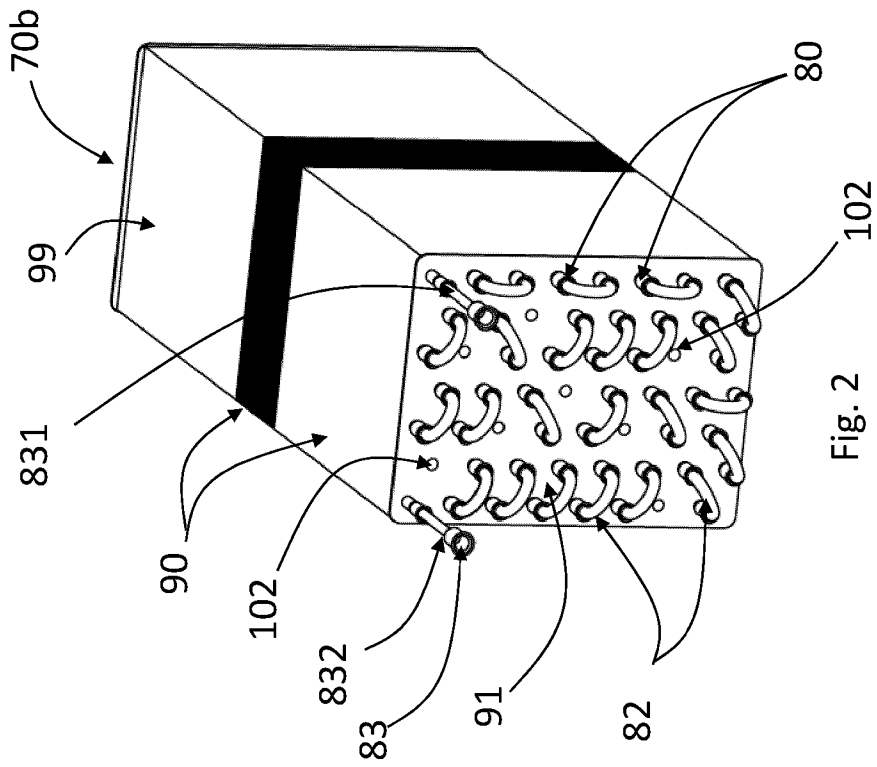
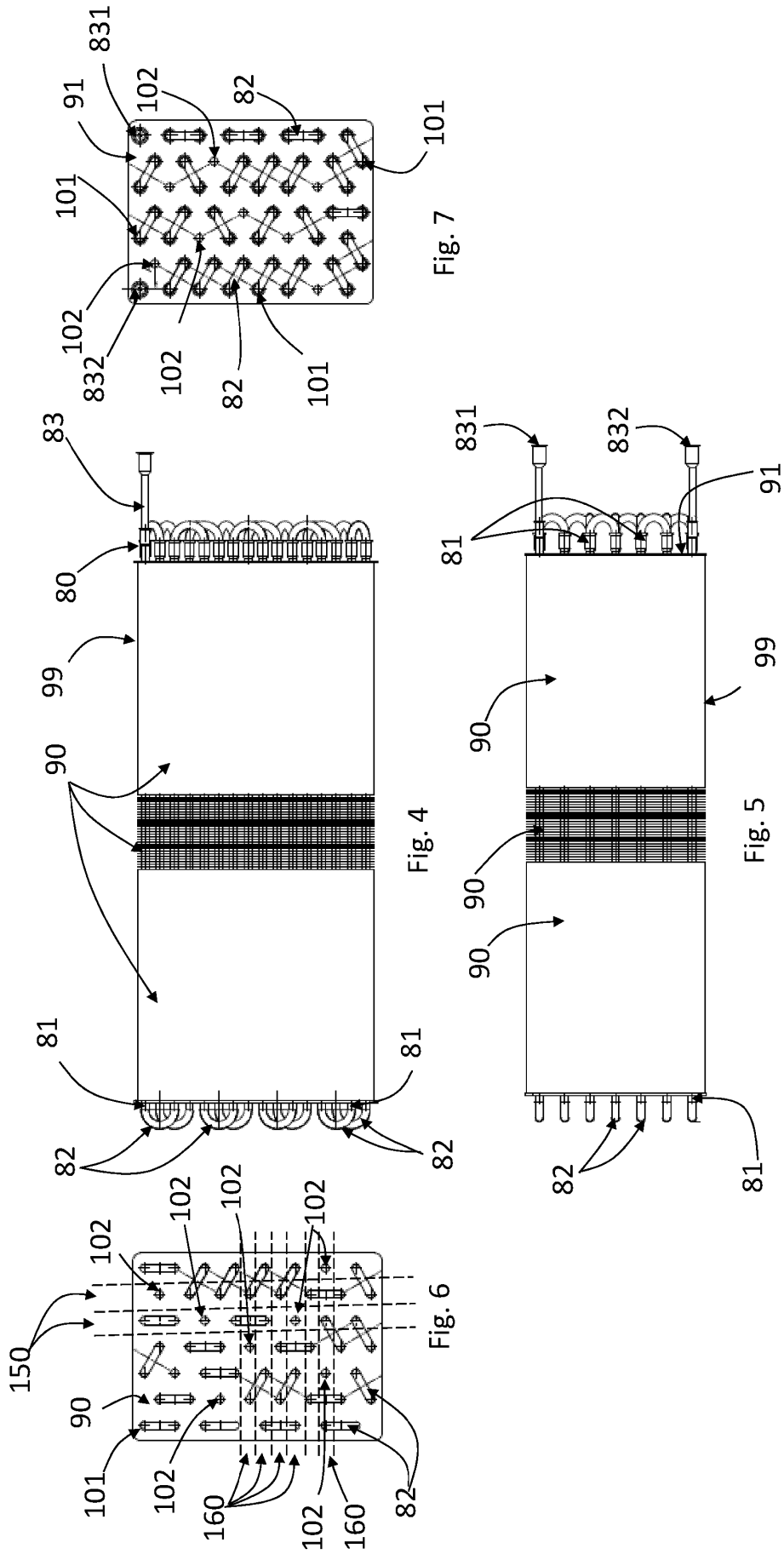

Fig. 2



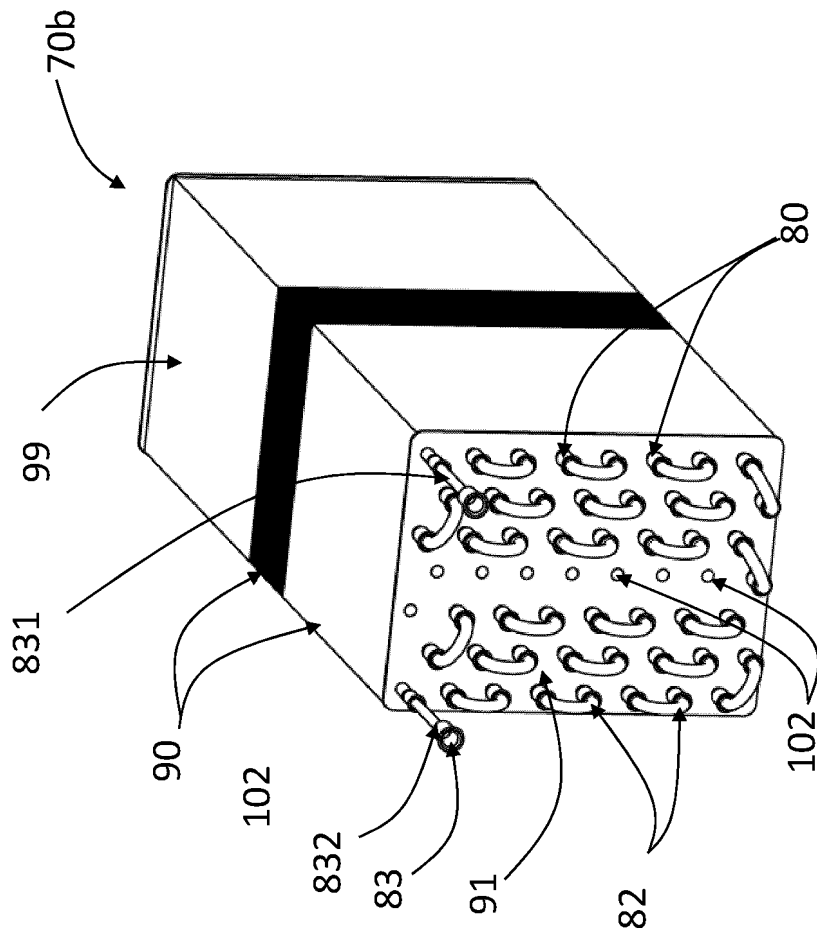
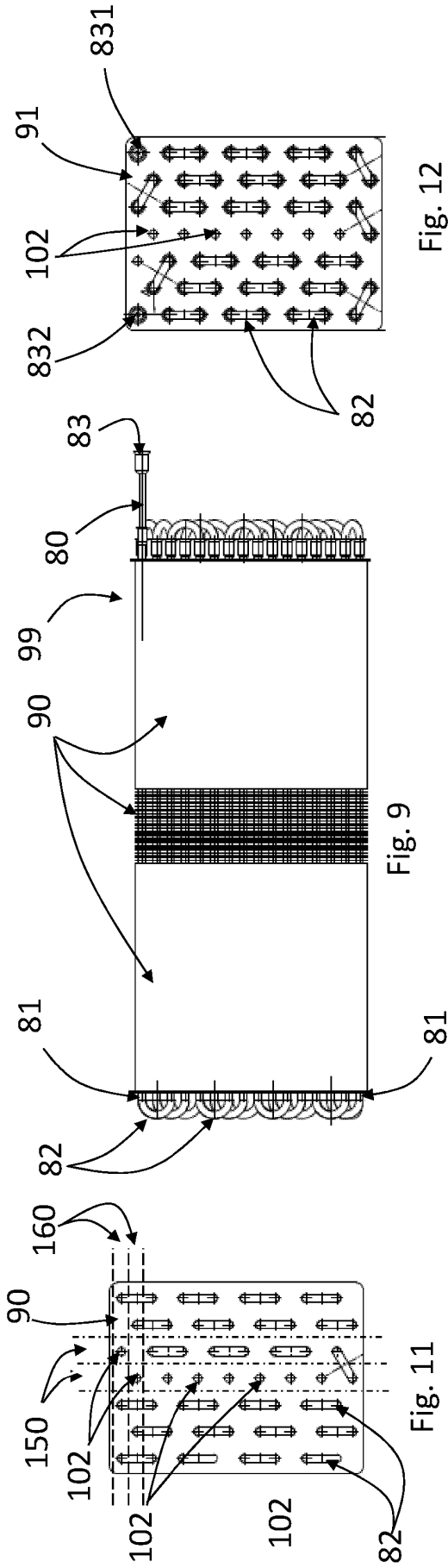

Fig. 8



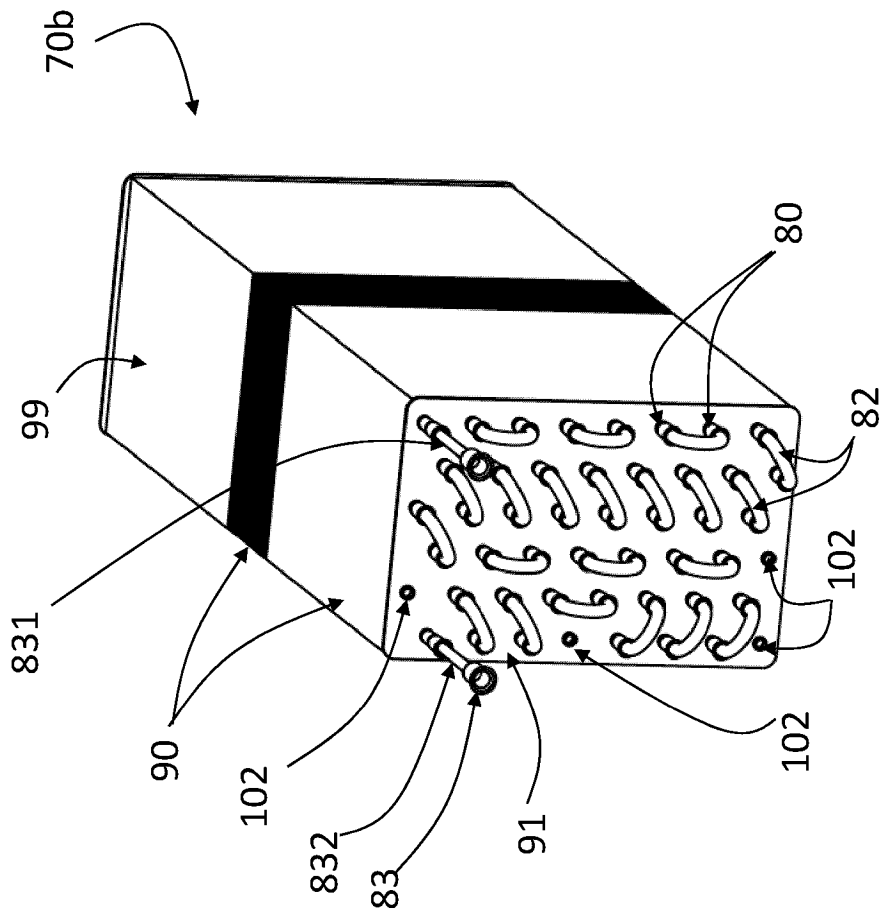

Fig. 13

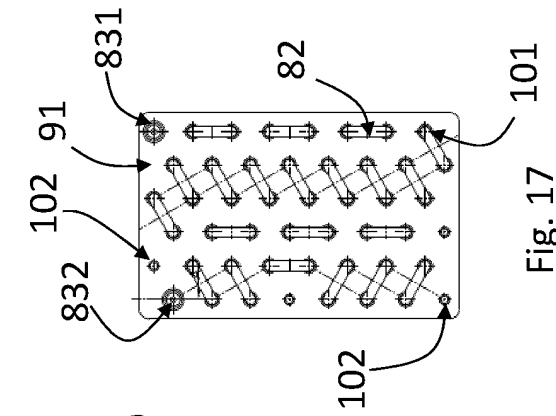

Fig. 14

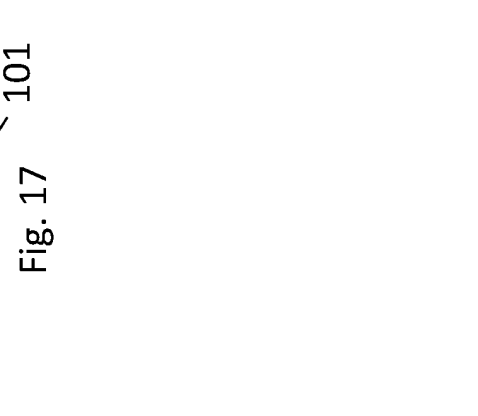

Fig. 15

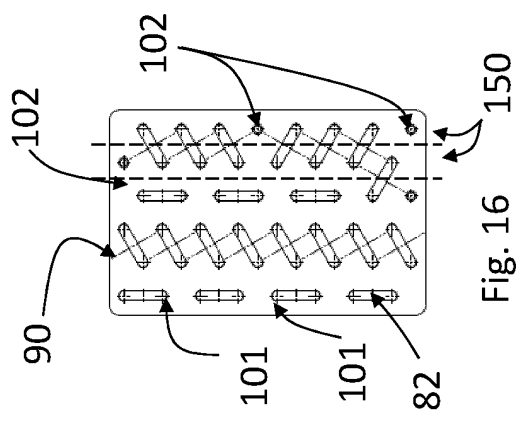

Fig. 16

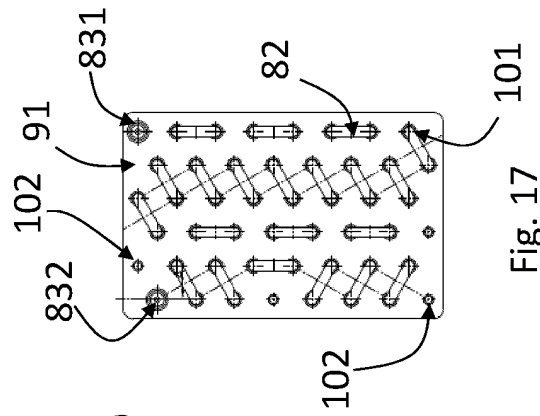

Fig. 17

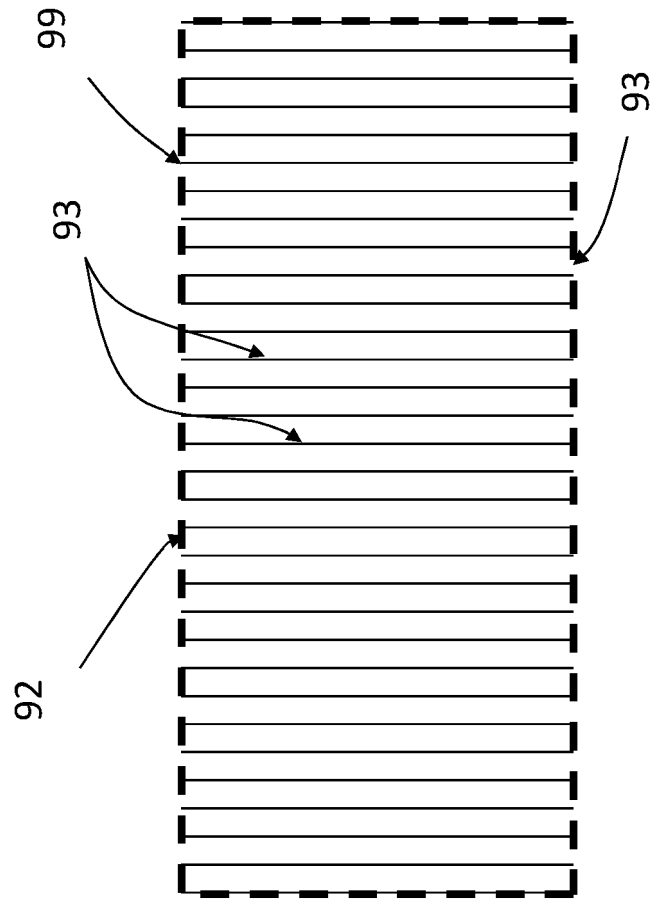

Fig. 18

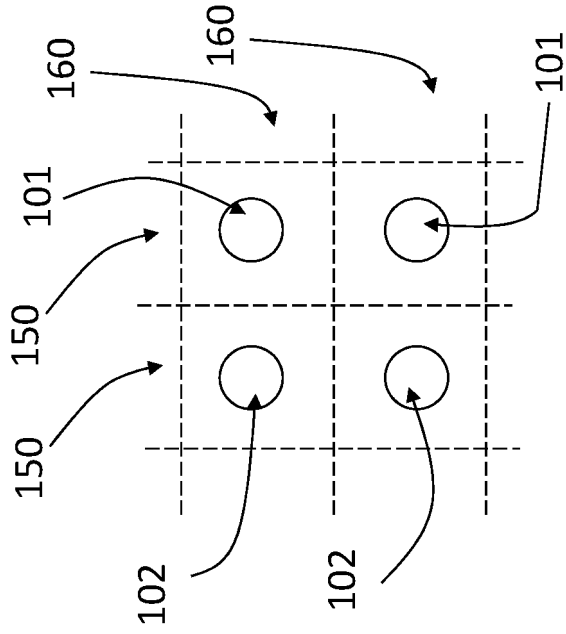

Fig. 19

REFERENCES CITED IN THE DESCRIPTION

This list of references cited by the applicant is for the reader's convenience only. It does not form part of the European patent document. Even though great care has been taken in compiling the references, errors or omissions cannot be excluded and the EPO disclaims all liability in this regard.

Patent documents cited in the description

- DE 102015120487 [0018]
- EP 3066406 A1 [0018]
- EP 3279393 A1 [0019]